



**EF\*\*20FD-MH SERIES - MANUFACTURED HOUSING ELECTRIC FURNACE**





**1. Safety Instruction**

Potential safety hazards are alerted using the following symbols. The symbol is used in conjunction with terms that indicate the intensity of the hazard. It is the responsibility of the owner and the installer to read and comply with the safety information and the instructions accompanying these symbols.

 **WARNING** This symbol indicates a potentially hazardous situation, which if not avoided, could result in serious injury, property damage, product damage or death.

 **CAUTION** This symbol indicates a potentially hazardous situation, which if not avoided, may result in moderate injury or property damage.

 **WARNING** Certified technicians or those individuals meeting the requirements specified by NATE may use this information. Property and product damage or personal injury hazard may occur without such background. This appliance is not intended for use by persons (including children) with reduced physical, sensory, or mental capabilities, or lack of experience and knowledge, unless they have been given supervision or instruction concerning use of the appliance by a person responsible for their safety. Children must be supervised to ensure that they do not play with the appliance. Product designed and manufactured to permit installation in accordance with local and national building codes. It is the installer's responsibility to ensure that the product is installed in strict compliance with the aforementioned codes. Manufacturer assumes no responsibility for damage (personal, product or property) caused due to installations violating regulations.

 **CAUTION** Only factory authorized kits and accessories should be used when installing or modifying this unit unless it is so noted in these instructions. Some localities may require a licensed installer/service personnel.

 **WARNING** The unit is designed for operation with 208/240 V, single phase, 60 Hz power supply. ACiQ will not be responsible for damages caused due to modification of the unit to operate with alternative power sources.

 **WARNING** If any hot work is to be conducted on the refrigerating equipment or any associated parts, appropriate fire extinguishing equipment shall be available to hand. Have a dry powder or CO2 fire extinguisher adjacent to the charging area.

 **WARNING** Disconnect ALL power before servicing or installing this unit. Multiple power sources may be present. Failure to do so may cause property damage, personal injury, or death.

 **WARNING** Do not bypass safety devices.

 **WARNING** Product designed and manufactured to permit installation in accordance with local and national building codes. It is the installer's responsibility to ensure that product is installed in strict compliance with national and local codes. Manufacturer takes no responsibility for damage (personal, product or property) caused due to installations violating regulations. In absence of local/state codes, refer to National Electric Code: NFPA 90A & 90B Uniform Mechanical Code.

 **WARNING** This unit is NOT approved from outdoor installations.

 **WARNING** When this unit is installed in an enclosed area, such as a garage or utility room with any Carbon Monoxide producing devices (i.e. automobile, space heater, water heater etc.) ensure that the enclosed area is properly ventilated.

**2. Introduction**

This product is designed and manufactured to comply with national codes. The product shall be installed in accordance with national wiring regulations. It is the responsibility of the installer to follow such codes and / or prevailing local codes / regulations. The manufacturer assumes no responsibility for equipment installed in violation of any codes or regulations.

The EF\*\*20FD-MH Series air handlers are versatile Downflow or Upflow units. These air handlers have the following standard features:

**I. Application Versatility**

One unit for all, Downflow (Front Return) or Upflow (Bottom Return) as shipped (field-convertible for downflow-front & top return and downflow-top return).

**II. Cabinet**

Sturdy, galvanized steel cabinet with painted doors. Cabinet fully insulated with 1/2" faced insulation and anti-microbial, to encapsulate glass fibers and to provide excellent R- value. Stick pins ensure insulation remains in place. Units ship with disposable filter in filter rails. Max coil assembly height of 27.5".

### III. Heat Kits

EF\*\*20FD-MH Series air handler heat kits are factory installed and available from 10 to 20 kW. Models with electric heat include sequencers and temperature limit switches for safe, efficient operation. Controls are accessible from the front for easy service. Electrical connections can be made from either side of the cabinet. Disconnect does not protrude through the wall panel. Fan time delay relay standard for increased efficiency. Replacement heat kits are available with either breakers or terminal blocks and easily installed in the field using molex plugs.

### IV. Blower

Direct drive multi-speed blowers circulate air quietly and efficiently. ECM motors in the EF\*\*20FD-MH allow for precise air volume selection. Motor speeds can be easily selected via motor terminals. Blowers mounted on rails so they can be easily removed for service.

### 3. Inspection

On receiving the product, visually inspect it for any major shipping related damages. Shipping damages are the carrier's responsibility. Inspect the product labels to verify the model number and options are in accordance with your order. The manufacturer will not accept damage claims for incorrectly shipped product.

Repair and maintenance to electrical components shall include initial safety checks and component inspection procedures. If a fault exists that could compromise safety, then no electrical supply shall be connected to the circuit until it is satisfactorily dealt with. If the fault cannot be corrected immediately but it is necessary to continue operation, an adequate temporary solution shall be used. This shall be reported to the owner of the equipment, so all parties are advised.

#### Initial Safety Checks shall include:

- The capacitors are discharged: this shall be done in a safe manner to avoid possibility of sparking.
- That no live electrical components and wiring are exposed while charging, recovering, or purging the system.
- That there is continuity of earth bonding.

### 4. Installation Preparation

Read all the instructions in this guideline carefully while paying special attention to the WARNING and CAUTION alerts. If any of the instructions are unclear, clarify with certified technicians. Gather all the tools needed for successful installation of the unit prior to beginning the installation.

#### 4A. Clearances

This unit is designed for zero clearance installation on three sides and adequate clearance to provide access for service in the front. A minimum of 18" (alcove) or 6" (closet) clearance is recommended on the front end (Fig 4A-1).

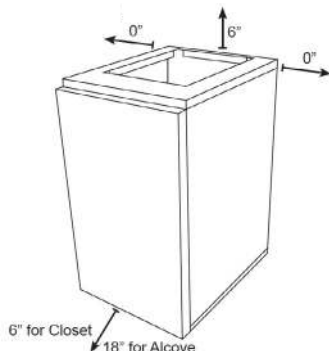



Fig 4A-1.  
Minimum Clearance  
for Electric Furnace

For closet installation, the return air opening can be on the front door, above the furnace casing on a wall, or on the electric door's louvered door (If applicable.)

A minimum clearance of six inches is required, on the return side, to allow for proper airflow.

### 4B. Closet and Alcove Installation

**CAUTION** Ensure that the unit is adequately sized. The tonnage of the outdoor unit should never exceed the tonnage of this unit.

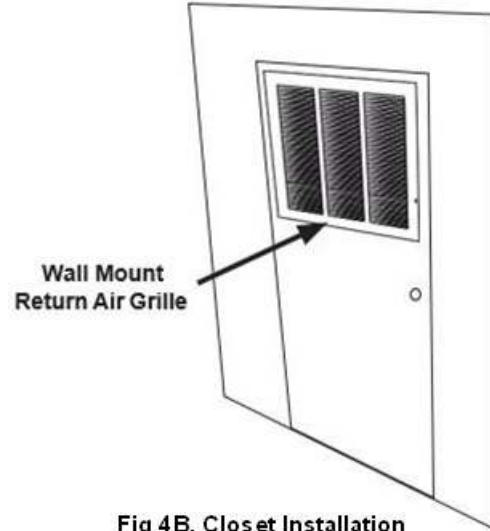

Fig 4B. Closet Installation

Airflow must be available to the electric furnace's return. Not doing so may cause improper heating as well as premature heating element failure.

#### 4B-1. Air Handler Orientation

This unit is designed to be installed in Downflow/Front Return orientation (see Figure 4B-1A). Optional upflow kit (not included) required to install in Upflow/Bottom Return orientation (see Figure 4B-1B). See section 4 for more information on easily aligning the single door onto the final assembly.

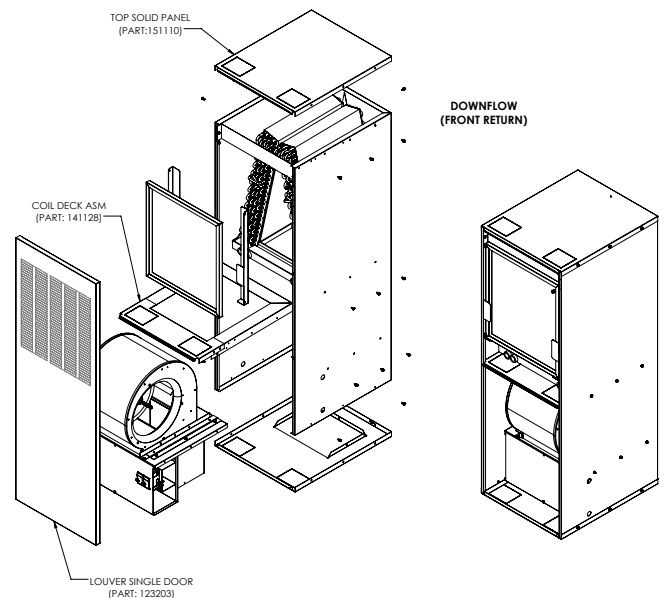

Fig. 4B-1A (Downflow – Front Return)

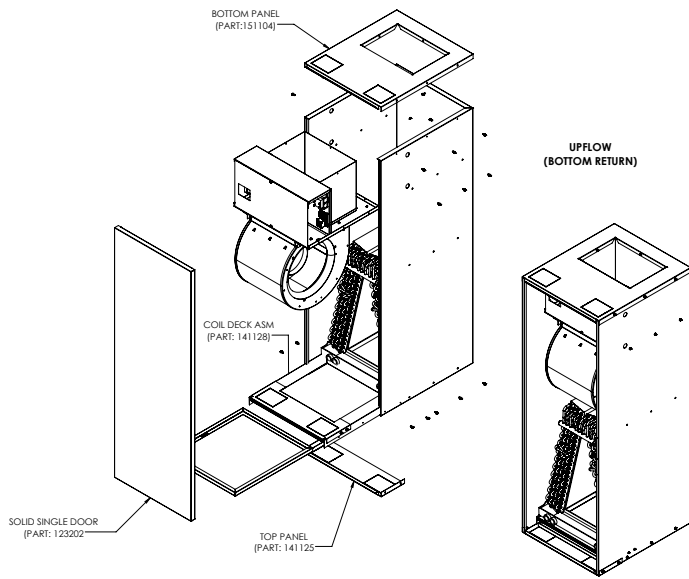

Fig 4B-1B (Upflow – Bottom Return)

## 4B-2. Coil Deck Reconfiguration

**Step 1:** Remove Coil Deck from unit and disassemble. (Figure 4B-2A).

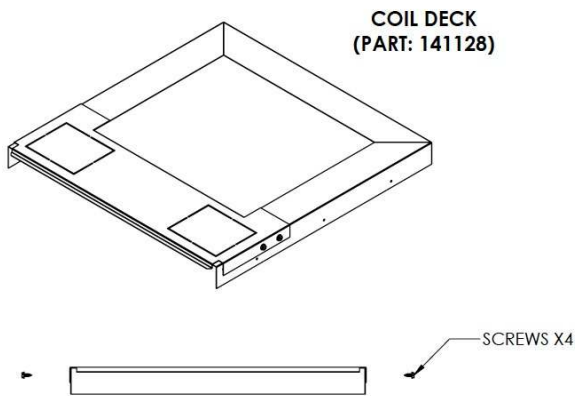

Fig. 4B-2A

**Step 2:** Configuring the Coil Deck Assembly, extend coil assembly when in a downflow configuration (Figure 4B-2B) and collapse the assembly when in an upflow configuration (Figure 4B-2C).

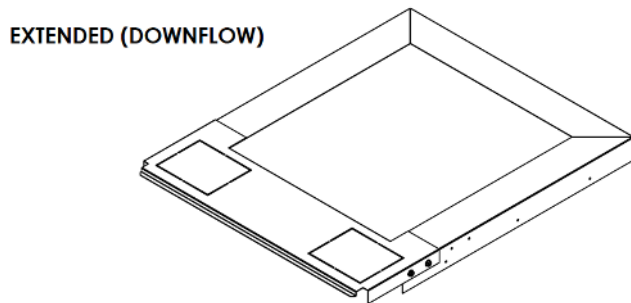

Fig. 4B-2B

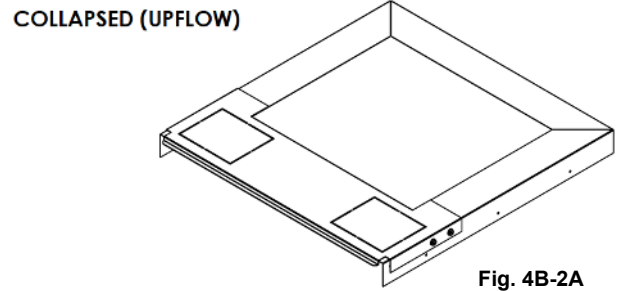

Fig. 4B-2A

## 4B-3. Filter Care

The filter should be checked every month. You may replace the filter by simply removing the single door and sliding out the existing one to replace it with a new filter.

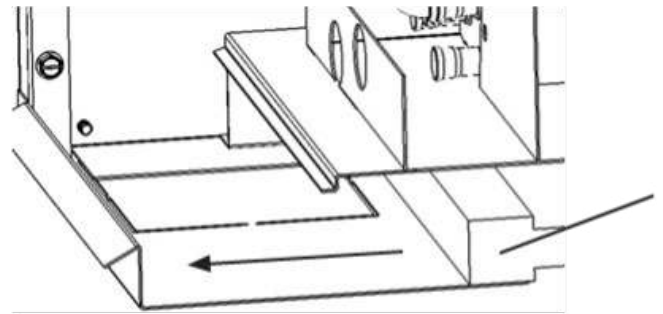

Fig. 4B-3A

## 4B-4. Door Mounting

When installing the single door onto the final assembly EF\*\*20FD-MH follow these steps:

- While standing in front of the unit, insert bottom flange at an angle into the unit. (Fig. 4B-4A)
- Lift the top of the single door into the Door Hook from the top panel (v-feature) at upright position to slowly slide down the door into feature. (Fig. 4B-4B)

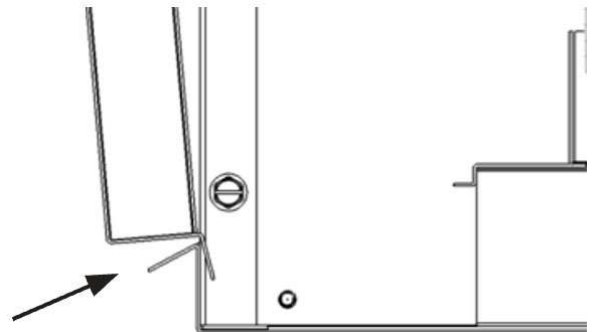

Fig. 4B-4A

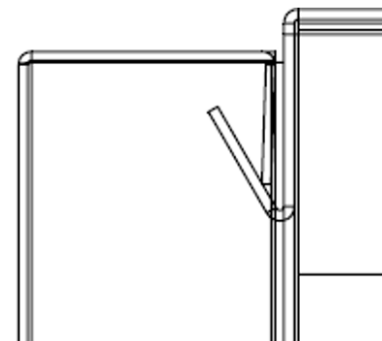

Fig. 4B-4B

# 4C. Conversion Kits

ONE PIECE WRAPPER - CONFIGURATION TABLE					
BROCK AIR MODEL (DEFAULT)	CONFIGURATION (DEFAULT)	RETURN (DEFAULT)	DOOR (DEFAULT)	CONVERTIBLE TO	KIT NEEDED FOR CONVERSION
EF1020FD-MH EF1520FD-MH	DOWNFLOW	FRONT	LOUVERED	DOWNFLOW / FRONT & TOP RETURN – LOUVER DOOR	AEXK-01
EF2020FD-MH				DOWNFLOW / TOP RETURN – SOLID DOOR	AEXK-02
				UPFLOW / BOTTOM RETURN – SOLID DOOR	AEXK-02

## 4D-1. KIT# AEXK-01 (DOWNFLOW/FRONT RETURN to DOWNFLOW/FRONT & TOP RETURN)

KIT#: AEXK-01

### DOWNFLOW/FRONT RETURN TO DOWNFLOW/FRONT & TOP RETURN CONVERSION

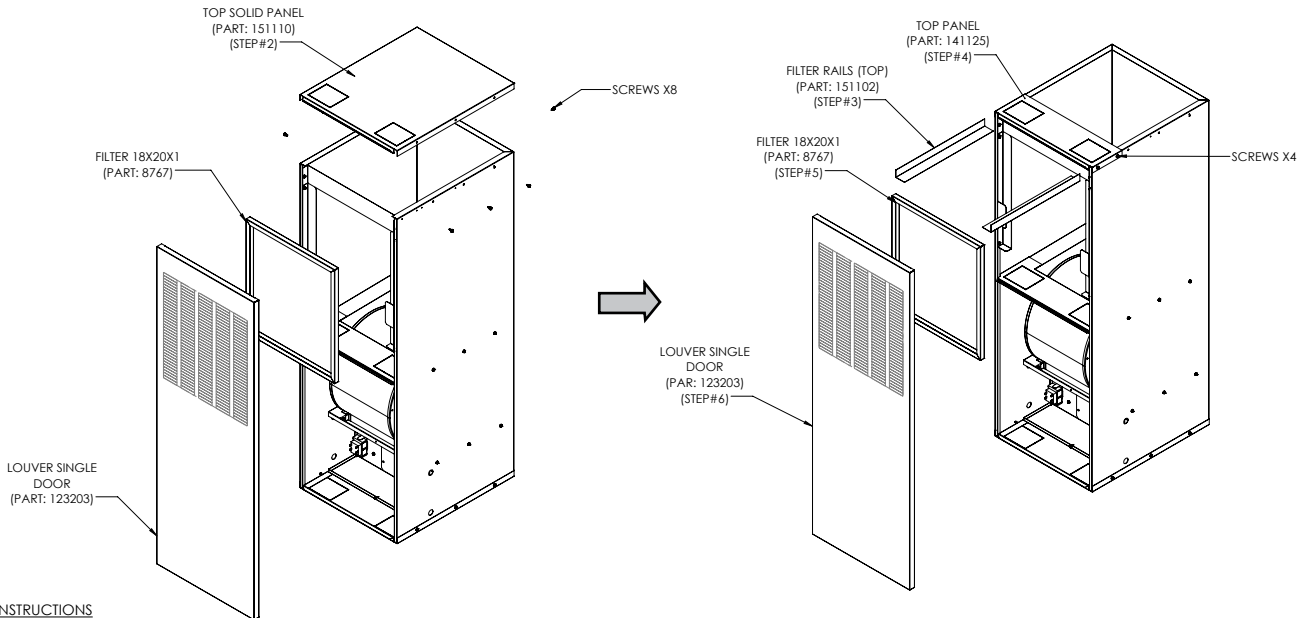

**INSTRUCTIONS**

- STEP 1: REMOVE THE DOOR (123203), FILTER & TOP SOLID PANEL (151110)
- STEP 2: DISCARD THE PART# 151110
- STEP 3: MOUNT FILTER RAILS (151102) IN THE TOP INSIDE LEFT & RIGHT OF UNIT WITH SCREWS
- STEP 4: MOUNT TOP PANEL (141125) ON TOP OF UNIT WITH SCREWS
- STEP 5: SLIDE IN FILTER INTO THE FILTER RAILS
- STEP 6: MOUNT THE LOUVERED DOOR (123203) - REFER I/O FOR DOOR MOUNTING

ALL PARTS MAY NOT BE USED - SEE INSTRUCTIONS

PARTS NEEDED FOR CONVERSION			
ITEM #	PART #	DESCRIPTION	QTY
1	141125	TOP PANEL	1
2	151102	FILTER RAILS (L&R)	2

## 4D-2. KIT# AEXK-02 (DOWNFLOW/FRONT RETURN to DOWNFLOW/TOP RETURN)

KIT#: AEXK-02

### DOWNFLOW/FRONT RETURN TO DOWNFLOW/TOP RETURN CONVERSION

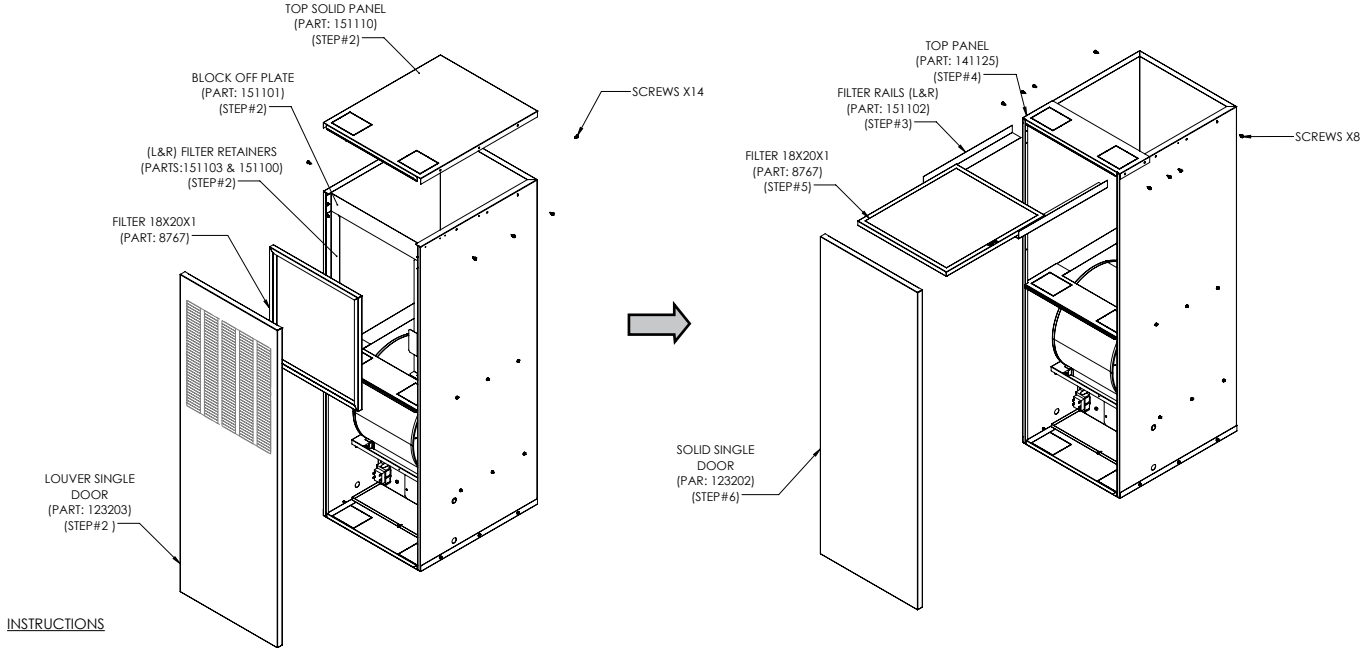

#### INSTRUCTIONS

- STEP 1: REMOVE THE DOOR (123203), FILTER, FILTER RETAINERS (151100 & 151103), BLOCK OFF PLATE (151101) & TOP SOLID PANEL (151110)  
 STEP 2: DISCARD THE PARTS# 123203, 151100, 151101, 151003 & 151110  
 STEP 3: MOUNT FILTER RAILS (151102) IN THE TOP INSIDE LEFT & RIGHT OF UNIT WITH SCREWS  
 STEP 4: MOUNT TOP PANEL (141125) ON TOP OF UNIT WITH SCREWS  
 STEP 5: SLIDE IN FILTER INTO THE FILTER RAILS  
 STEP 6: MOUNT THE SOLID DOOR (123202) - REFER I/O FOR DOOR MOUNTING

ALL PARTS MAY NOT BE USED - SEE INSTRUCTIONS

PARTS NEEDED FOR CONVERSION			
ITEM #	PART #	DESCRIPTION	QTY
1	141125	TOP PANEL	1
2	151102	FILTER RAILS (L&R)	2
3	123202	SOLID SINGLE DOOR	1

## 4D-3. KIT# AEXK-02 (DOWNFLOW/FRONT RETURN to UPFLOW/BOTTOM RETURN)

KIT#: AEXK-02

### DOWNFLOW/FRONT RETURN TO UPFLOW/BOTTOM RETURN CONVERSION

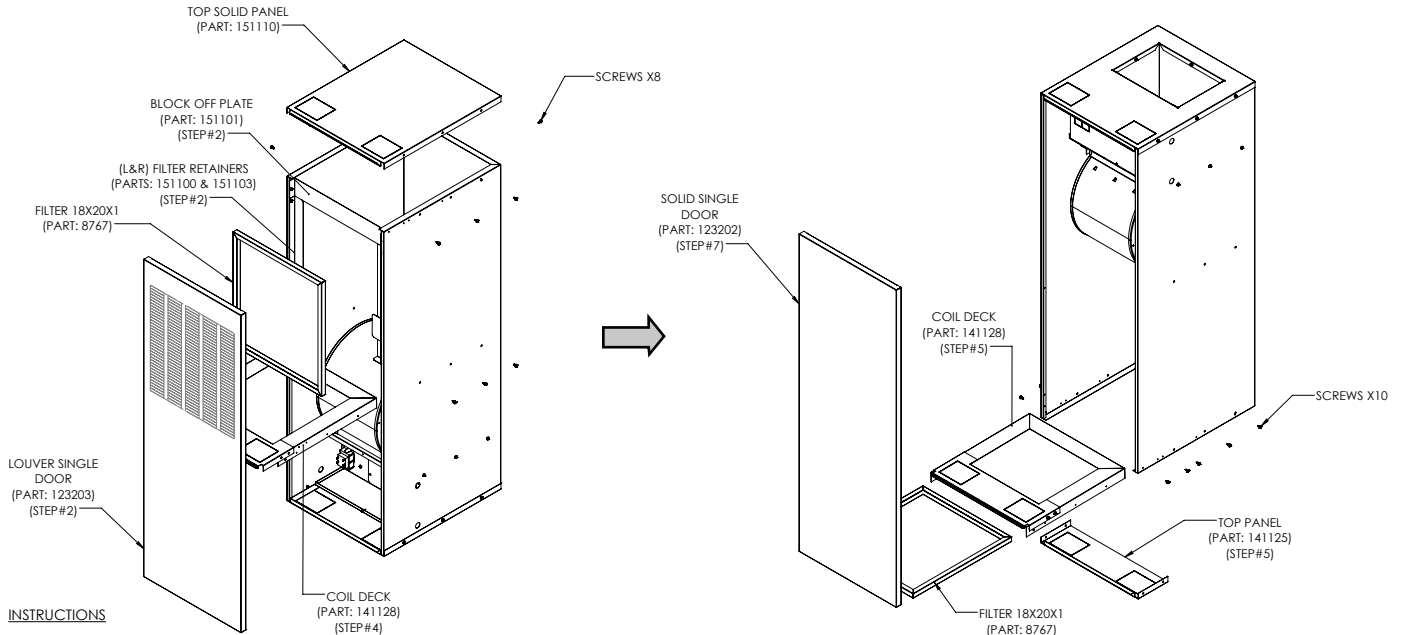

#### INSTRUCTIONS

- STEP 1: REMOVE THE DOOR (123203), FILTER, FILTER RETAINERS (151100 & 151103), COIL DECK (141128), SOLID TOP PANEL (151110) & BLOCK OFF PLATE (151101)  
 STEP 2: DISCARD THE PARTS# 123203, 151110, 151100, 151101 & 151103  
 STEP 3: FLIP UNIT UPSIDE DOWN  
 STEP 4: CONVERT COIL DECK (141128) INTO THE UPFLOW POSITION - REFER TO I/O FOR COIL DECK CONVERSION  
 STEP 5: MOUNT COIL DECK (141128) & TOP PANEL (141125) AT THE BASE ON UNIT USING SCREWS  
 STEP 6: SLIDE IN THE FILTER BELOW COIL DECK  
 STEP 7: MOUNT THE SOLID DOOR (123202) - REFER TO I/O FOR DOOR MOUNTING  
 STEP 8: DISCARD ANY LEFT OVER PARTS

ALL PARTS MAY NOT BE USED - SEE INSTRUCTIONS

PARTS NEEDED FOR CONVERSION			
ITEM #	PART #	DESCRIPTION	QTY
1	141125	TOP PANEL	1
2	123202	SOLID SINGLE DOOR	1

## 5. Ductwork and Duct Connector

Duct systems should be installed in accordance with standards for air-conditioning systems, National Fire Protection Association Pamphlet No. 90A or 90B. They should be sized in accordance with National Environmental System Contractors Association Manual K, or whichever is applicable. It is recommended that installers refer to the "Manufactured Housing Duct System Guide to Best Practices" by MHI-MHRA.

On any job, non-flammable flexible collars should be used for the return air and discharge connections to prevent transmission of vibration. Although these units have been specially designed for quiet, vibration-free operation, air ducts can act as soundboards if poorly installed.

All main supply and return air drops should be properly sized as determined by the designer of the duct system and should not necessarily be the size of the duct flange openings of the unit. (The duct size should never be smaller than the flange openings of the electric furnace supply and return air openings.)

### To install the duct connector:

1. Attach duct connector foam gasket along the perimeter of the duct opening to seal the duct connector to the top of the duct.
2. To connect the duct connector, insert it into the floor opening and bend back the tabs inside the duct. Fold the tabs over 90 degrees to ensure a secure connection. Seal around the duct connector.

### To install the duct connector continued:

3. Slit the corners of the duct connector that stick up above the floor, and then bend the sides over onto the floor surface.
4. Insulate between the floor base and the floor when used on a combustible floor. Be sure to cut the insulation around the perimeter of the duct connector opening.
5. Install the floor base over the floor opening with the flanges on the 11 x 13-inch opening facing down.
6. Use four screws to secure the floor base to the floor.

It is recommended that wherever supply and return air sheet metal ducts pass through unconditioned areas, they be insulated to prevent excessive heat loss during heating operation.

When applied in conjunction with summer air conditioning, sheet metal duct routed through unconditioned areas should be insulated and have an outside vapor barrier to prevent formation of condensation.

## 6. Electrical Installation



### WARNING

Disconnect ALL power before servicing or installing this unit. Multiple power sources may be present. Failure to do so may cause property damage, personal injury, or death.

These units are designed for single or three phase 208/240 volts, 60 HZ power supply. Wire selection and wiring must be in accordance with the National Electric Code and/or local codes. Unit terminals are designed to accommodate copper and aluminum wiring. If aluminum wiring is used: please observe special precautions relative to sizing, wire connections and corrosion protection.

All models with 5, 6, 8 or 10kW electric heat are arranged for single circuit connections. Models larger than 10kW are arranged for multi-circuit protection. Refer to the top part of wiring diagram at the end of this guide for detailed information.

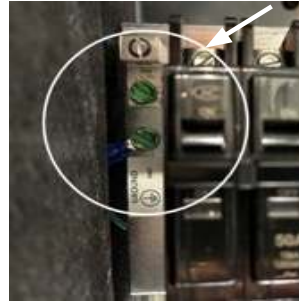

Line voltage wiring should be routed through the access holes at the top of the electric furnace. Proper electrical conduit connection fittings should be used. Connect the power wiring to the line side connections on the electric furnace. The electrical ground wire should be connected to the grounding lug. Ensure both the field supplied ground wire and electric furnace GREEN ground wire are both secured to the grounding lug of the electric furnace.

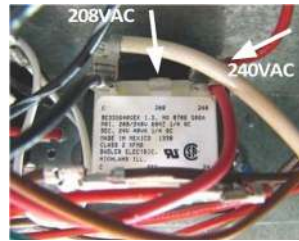

If the line voltage being supplied to the electric furnace is 208-volt single phase, the line voltage tap on the low voltage transformer needs to be moved from the 240-volt tap to the 208-volt tap. If this is not done, the secondary output voltage of the transformer will be too low.

## 6A. Single Stage Cooling with Electric Heat

The electric furnace is factory set for a single stage cooling system. If factory installed accessory electric heaters are pre-installed, the unit will also have a low voltage wire for the electric heat. (Fig 6A-1)



Fig. 6A-1

During cooling mode operation, the indoor blower G wire will energize a time delay relay inside the electric furnace. After a short time, delay period, the time delay relay contacts will close and apply power to the blower motor. Fan delay periods are 7 seconds ON delay and 65 seconds OFF delay (See Schematic).

The Y wire from the thermostat is not connected at the electric furnace. This wire goes directly to the outdoor unit 24 volt wiring to turn on the outdoor condensing unit when a call for cooling takes place. The 24-volt common for the outdoor unit

## 6A. Single Stage Cooling with Electric Heat CONTINUED

circuits is connected at the electric furnace Brown wire.

The electric heater low voltage wiring W terminal is wired directly from the thermostat to the electric furnace. The blower will delay a heat call ON for a period of 5 seconds. The OFF-delay period is 60 seconds.

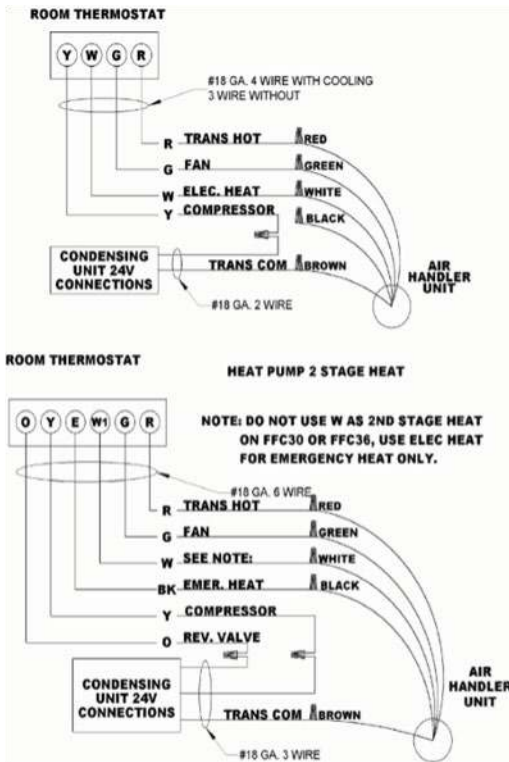

## 6B. Two Stage Condensing Units

If the outdoor condensing unit is a two-stage model, a field provided Y2 wire can be connected to the motor using an electrical spade connector. The number 4 and 5 terminals on the motor are speed taps that will increase the blower speed for second stage cooling operation. Both the G and Y2 terminals will be energized at the same time during a call for second stage blower speed operation. The motor will run at the speed where the Y2 wire is connected (Fig 6B-1).



Fig. 6B-1

## 7. Air Volume Adjustment

Air volume needs to be set to the level recommended by the outdoor unit equipment manufacturer. Most systems will require around 400 CFM of indoor air for every 1 ton of system cooling capacity. The air volume must be set prior to attempting system charge.

This electric furnace uses a 240V ECM motor. The air volume level produced by the electric furnaces at varying external static pressure levels are shown on table in Section 7 (Air Volume Adjustment).

1. Select a starting speed tap from the CFM table.
2. Call for fan only operation at the thermostat.
3. Read the external static pressure level on the Magne helic gauge.
4. Make speed tap selection changes to get the air volume as close as possible to the required level.
5. If the static pressure is above .5"wc, excessive turbulence or duct friction needs to be reduced. (Obstructions in the duct system can also cause excessive static pressure.)
6. When the proper air volume is established, move on to the charging procedure.

## 8. Air Volume Adjustment



### CAUTION

An improperly charged system may cause degradation in system performance and damage the compressor. After installation of the coil, refer to the outdoor unit manufacturer for charging techniques and amount of charge. If outdoor unit manufacturers charging instructions are unavailable; then refer to instructions below to charge the system.

1. Bring airflow up to maximum CFM possible according to table in Section 7 (Air Volume Adjustment table above).
2. Evacuate refrigeration system to micron level required by outdoor unit manufacturer.
3. Release system charge from outdoor unit and call for cooling.
4. Use outdoor unit equipment manufacturer specific charging charts if available and make proper charge adjustment based upon outdoor unit instructions.
5. If outdoor unit instructions and charts are not available, use ACIQ's provided charts. Make certain indoor air temperature is near comfort level setpoint 75F, prior to establishing superheat and subcooling levels.

## 9. Adjustment Of Heat Anticipator

After all connections are made, start-up and checkout must be performed before proper evaluation of the entire system can be made. Make sure that heat anticipator is properly set as noted on thermostat instructions. Load requirements can vary in each residence, and it may be necessary for the installer or homeowner to make slight adjustments to the heat anticipator setting for longer or shorter cycles. It is recommended to change the setting to no more than plus or minus 0.05 amps at a time. Greater changes can cause the unit to rapid cycle or remain on excessively. Measure anticipator circuit current with electric heaters energized and set anticipator to proper level.

## 7. Air Volume Adjustment Table

BLOWER DATA														
MODEL	SPEED TAP	MOTOR			CFM V EXTERNAL STATIC									
		HP	AMPS	VOLTAGE	0.1	0.2	0.3	0.4	0.5	0.6	0.7	0.8	0.9	1.0
EF1020FD & EF1520FD	T-1	1/2	3.6	240	710	650	590	530	470	460	410	340	-	-
	T-2				770	720	670	630	570	510	450	420	370	340
	T-3				900	850	810	800	705	660	610	560	510	480
	T-4				1130	1100	1060	1020	980	940	900	850	810	760
	T-5				1310	1280	1240	1200	1165	1130	1080	1050	1010	970
EF2020FD	T-1	1	7.0	240	1130	1100	1060	1020	965	900	860	810	750	690
	T-2				1340	1300	1265	1230	1200	1155	1115	1050	1020	975
	T-3				1490	1450	1420	1400	1365	1330	1300	1270	1235	1170
	T-4				1670	1640	1610	1585	1550	1520	1500	1460	1430	1400
	T-5				1850	1825	1800	1770	1750	1720	1690	1670	1640	1620

\*Dry coil with Filter

## 10. Final System Checkout

1. Make certain all cabinet openings are properly sealed and any grommets moved during installation are moved into the proper place.
2. With cooling system operating, check for condensate leakage.
3. Perform leak detection inspection of refrigerant circuit and connecting piping.
4. Secure all cabinet doors.

## 12. Wiring Diagram for EF\*\*20FD-MH Model

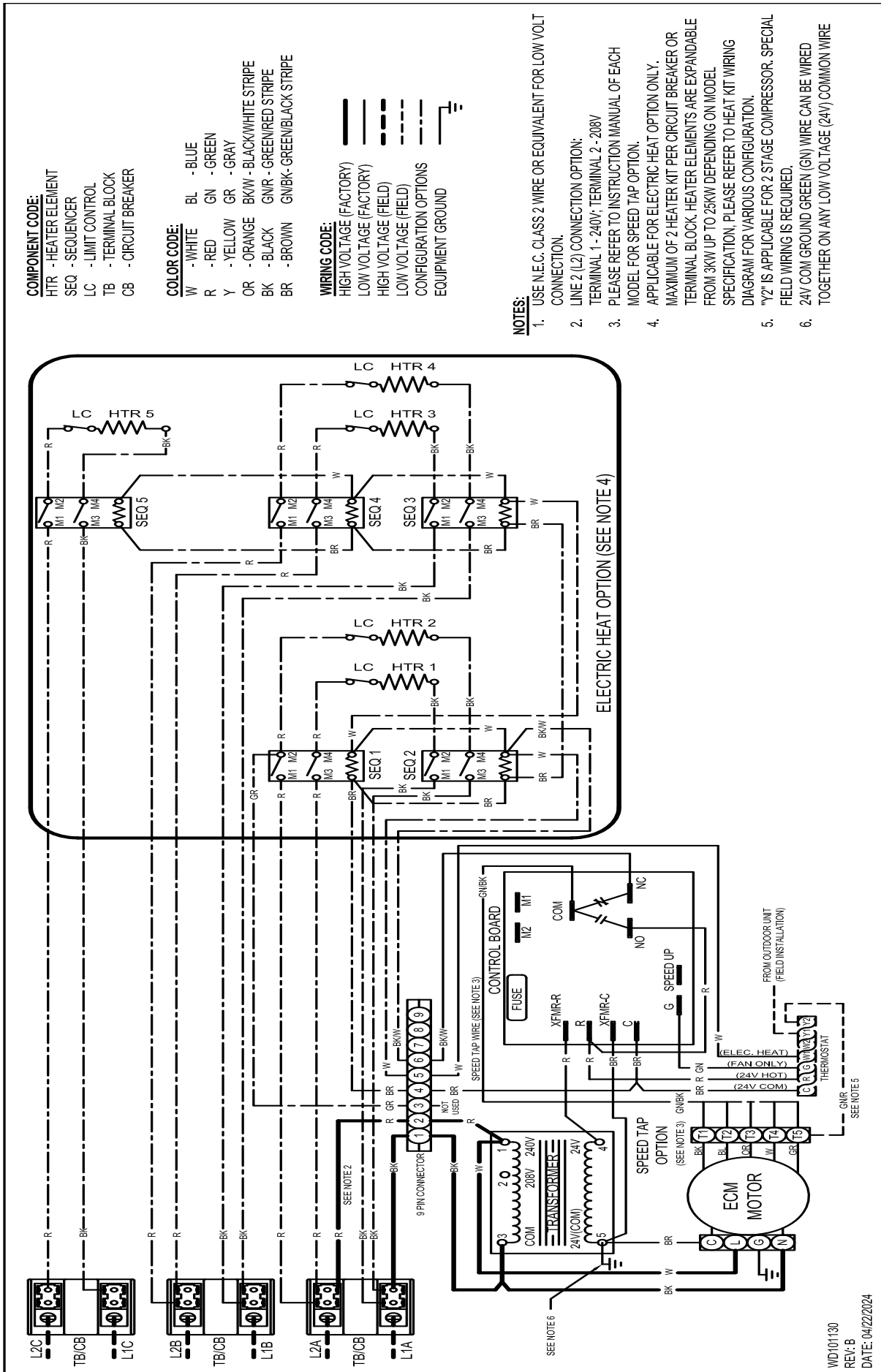

**HIGH VOLTAGE - Disconnect ALL power sources prior to servicing. Failure might lead to a safety hazard.**

**WIRING DIAGRAM IS SUBJECT TO CHANGE, ALWAYS REFER TO THE DIAGRAM ON THE MOST UP TO DATE INFORMATION**



2331 West State Route 55  
Troy, OH 45373  
Phone: 1-877-909-ACiQ  
[www.aciq.com](http://www.aciq.com)

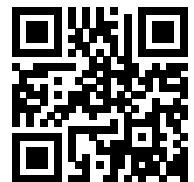

Revised 09-2024. Subject to change without notice and without incurring obligation.

© Copyright 2024 ACiQ. All Rights Reserved.

IO-B300 | Revision B