

HeatMaster

200 N

200 F

**INSTALLATION,
OPERATION &
MAINTENANCE**



Instructions for the User and the Installer

TABLE OF CONTENTS	2	STARTING UP	14
WARNINGS	3	Filling the domestic hot water and heating circuits	14
Who should read these Instructions	3	Starting up the Boiler	14
Symbols	3	Bleeding the Heating Circuit	14
USER'S GUIDE	4	MAINTENANCE	15
Using the Boiler	4	Annual maintenance	15
Heating System Pressure	5	Boiler maintenance	15
Burner safety mechanism	5	Maintenance of the safety devices	15
Burner Troubleshooting	5	Burner maintenance	15
APPLIANCE DESCRIPTION	6	Draining the boiler	15
TECHNICAL CHARACTERISTICS	7	DECLARATION OF CONFORMITY	16
Dimensions	7		
Burner chamber plate	7		
Boiler Clearance	7		
Combustion Characteristics	8		
Hydraulic Characteristics	8		
DHW performance *	8		
Maximum Operating Conditions	8		
Chimney Connection Characteristics	9		
Boiler Room	9		
Chimney Connection	9		
INSTALLATION	11		
DHW Connection	12		
Heating connection	13		

CERTIFICATION

The appliances bear the "CE" mark, in accordance with the standards in force in the various countries [European Directives 92/42/EEC "Efficiency", 2009/142/EC "Gas Appliances"]. These appliances also bear the Belgian gas boiler quality labels "HR+" [gas boiler] and "Optimaz" (oil boilers) labels.



Certified quality system ISO 9001

WHO SHOULD READ THESE INSTRUCTIONS

The manual should be read by:

- The specifying engineer
- The user
- The installer
- The maintenance technician

SYMBOLS

The following symbols are used in this manual:



Essential instruction for the correct operation of the installation



Essential instruction for the safety of persons and the environment



Danger of electrocution



Risk of scalding

WARNINGS

If you smell gas:

- Immediately isolate the gas supply.
- Open windows and doors to ventilate the area.
- Do not use any electrical appliances and do not operate any switches.
- Immediately notify your gas supplier and/or your installer.



This manual is part of the items delivered with the appliance and must be given to the user and stored in a safe place!

An approved installer must carry out the installation, starting up, maintenance and repair of the system, in accordance with current standards in force.

The manufacturer declines all liability for any damage caused as a result of incorrect installation or in the event of the use of appliances or accessories that are not specified by the manufacturer.



The manufacturer reserves the right to change the technical characteristics and features of its products without prior notice.



The availability of certain models as well as their accessories may vary according to markets.

RECOMMENDATIONS



- Please carefully read this manual before installing and starting up the boiler.
- It is prohibited to carry out any modifications to the inside of the appliance without the manufacturer's prior and written agreement.
- The product must be installed and serviced by an approved and qualified engineer, in accordance with applicable standards and regulations.
- Failure to comply with the operation instructions and test procedures can result in personal injury or a risk of environmental pollution.
- To guarantee safe and correct operation of the appliance, it is important to have it serviced and maintained every year by an approved installer or maintenance contractor.
- In case of anomaly, please call your service engineer.
- In spite of the strict quality standards that ACV applies to its appliances during production, inspection and transport, faults may occur. Please immediately notify your approved installer of any faults.
- The defective parts may only be replaced by genuine factory parts.



- Before carrying out any work on the boiler, it is important to isolate the electrical supply to the unit.
- The user must not attempt to gain access to the components inside the boiler or the control panel.
- This appliance is not intended for use by persons (including children) with reduced physical, sensory or mental capabilities, or lack of experience and knowledge, unless supervised or unless they have been given instruction concerning the use of the appliance by a person responsible for their safety.

USING THE BOILER



Make sure to have your installation inspected and maintained, if required, at least once a year by an approved and qualified engineer. More frequent servicing may be required depending on boiler use. If this is the case, consult your installer for advice.

Starting the burner:

In normal operation, the burner starts automatically as soon as the boiler temperature drops below the set temperature.

GETTING FAMILIAR WITH THE CONTROL PANEL

The user must not attempt to gain access to the components inside the control panel.

- **Master switch** - Is used to turn the **HeatMaster®** on or off.
- **Control thermostat - 60-90 °C** - When using the **HeatMaster®** as a hot water generator only, the temperature can be set between 60 °C and 90 °C. If the **HeatMaster®** is used for both domestic hot water (DHW) and central heating, the control thermostat would normally be set at 80 °C to achieve optimum operating conditions.
- **Summer/winter switch** - Is used to turn the heating pump (if fitted) on or off.
- **Manual reset high limit thermostat** - If the boiler temperature exceeds 103 °C, this safety device will activate and the high temperature indicator will light up. To reset - first allow the boiler to cool to below 60 °C, unscrew the cap and press the reset button using a pencil or similar pointed device, then reinstall the cap. If the fault persists, turn the boiler off and call a service engineer.
- **Daily timer** - Allows the **HeatMaster®** to be turned on and off at specific moments of the day and operates on a 24 hour sequence. A series of white tabs are set around the timer, each tab corresponding to a 15 minute switching period. To set the timer, simply push outwards the number of tabs required for ON period.

Remember: Tab in = **HeatMaster®** OFF
 Tab out = **HeatMaster®** ON

- **Temperature and pressure gauge** - This gauge indicates both the temperature of the **HeatMaster®** and the pressure within the primary circuit. The temperature should not exceed 90 °C - if it does, switch the boiler off and check the thermostat setting. If the fault persists, call an engineer. The pressure should not fall below 0.1 MPa (1 bar), if it does, please see the 'Heating System Pressure' paragraph further in this section.
- **Low primary water pressure indicator** - If this indicator lights up, the primary circuit of the **HeatMaster®** requires topping up with water. Please see the 'Heating System Pressure' paragraph later in this section.

HeatMaster® 200 N and 200 F Control Panel

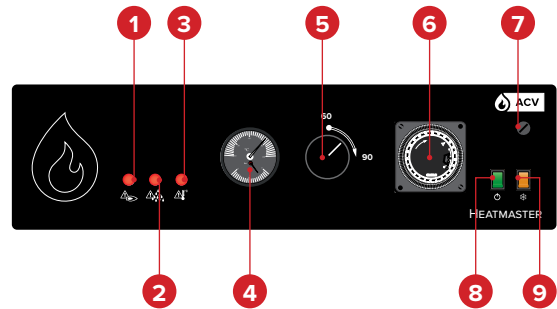

1. Burner safety cutout warning indicator
2. Low primary water pressure indicator
3. High limit thermostat indicator
4. Temperature and pressure gauge
5. Control thermostat
6. Daily timer
7. Manual reset high limit thermostat
8. Master switch
9. Summer/winter switch

HEATING SYSTEM PRESSURE



From time to time you may need to top up the heating circuit water level to get the required pressure in the system. The circuit pressure is indicated by the combined temperature and pressure gauge on the boiler control panel.

The minimum pressure when the boiler is cold should be 0.1 MPa (1 bar). The precise operating pressure required depends on the height of the building and your installer will have informed you of this value at the time of installation (see Starting up section - Filling the DHW and heating circuits).

If the pressure falls below 0.1 MPa (1 bar), the boiler water pressure switch will turn the boiler off until the pressure is restored

To restore the pressure, top up the heating circuit with water by opening the filling valve **A** of the boiler primary circuit and allow the system to fill. Once the pressure gauge of the boiler control panel indicates the required pressure, close the filling valve.

Safety valves

If water discharges from any of the safety valves, turn the boiler off and call a service engineer.

BURNER SAFETY MECHANISM

RESETTING THE OIL BURNER

- **HeatMaster® 200 F**
 - ➔ The safety lockout indicator is located on the burner and on the control panel.

The red warning light indicates an operating fault. Wait 5 minutes before resetting the burner. To reset: press the button located on the burner.

If the burner does not restart, call a service engineer after ensuring the fault is not due to a power failure or low oil level in the tank.

BURNER TROUBLESHOOTING

For all burners, please refer to the relevant servicing and troubleshooting instructions in the technical manual of your burner.

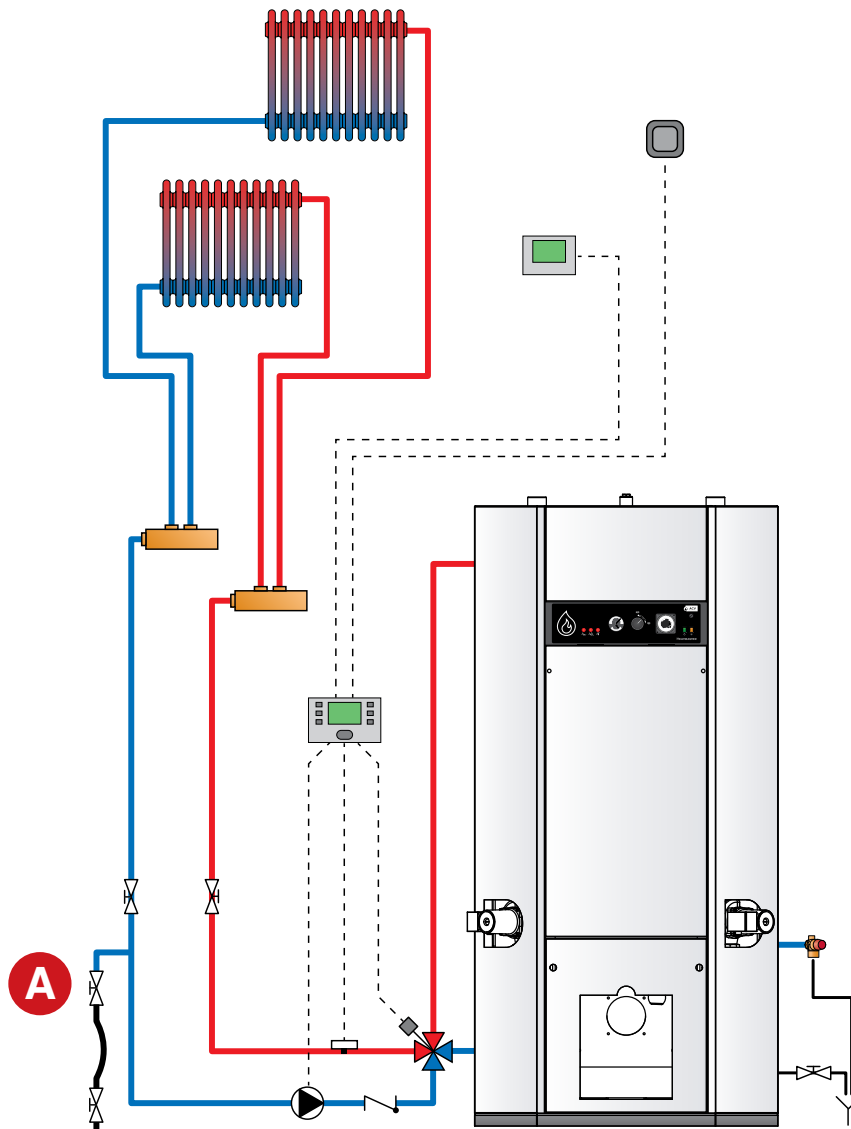

Description HeatMaster® 200 N / 200 F

- | | |
|---|--|
| <ol style="list-style-type: none"> 1. Chimney reduction with horizontal outlet (vertical outlet optional) 2. Cold water inlet 3. T&P valve connection (optional) 4. Auto-air vent 5. Rigid polyurethane foam insulation 6. Flue gas tubes and turbulators 7. Burner chamber plate 8. Charging pump (2x) 9. Heating flow 10. Domestic hot water outlet 11. Primary expansion vessel (4x) 12. Internal stainless steel tank | <ol style="list-style-type: none"> 13. Heating return 14. Drain cock 15. Primary circuit tank 16. Combustion chamber
<ol style="list-style-type: none"> A. Automatic reset high limit thermostat B. Manual reset high limit thermostat C. Thermometer D. DHW priority thermostat E. Low water pressure switch F. Pressure gauge connection G. Thermostat control bulb H. Primary circuit safety valve |
|---|--|

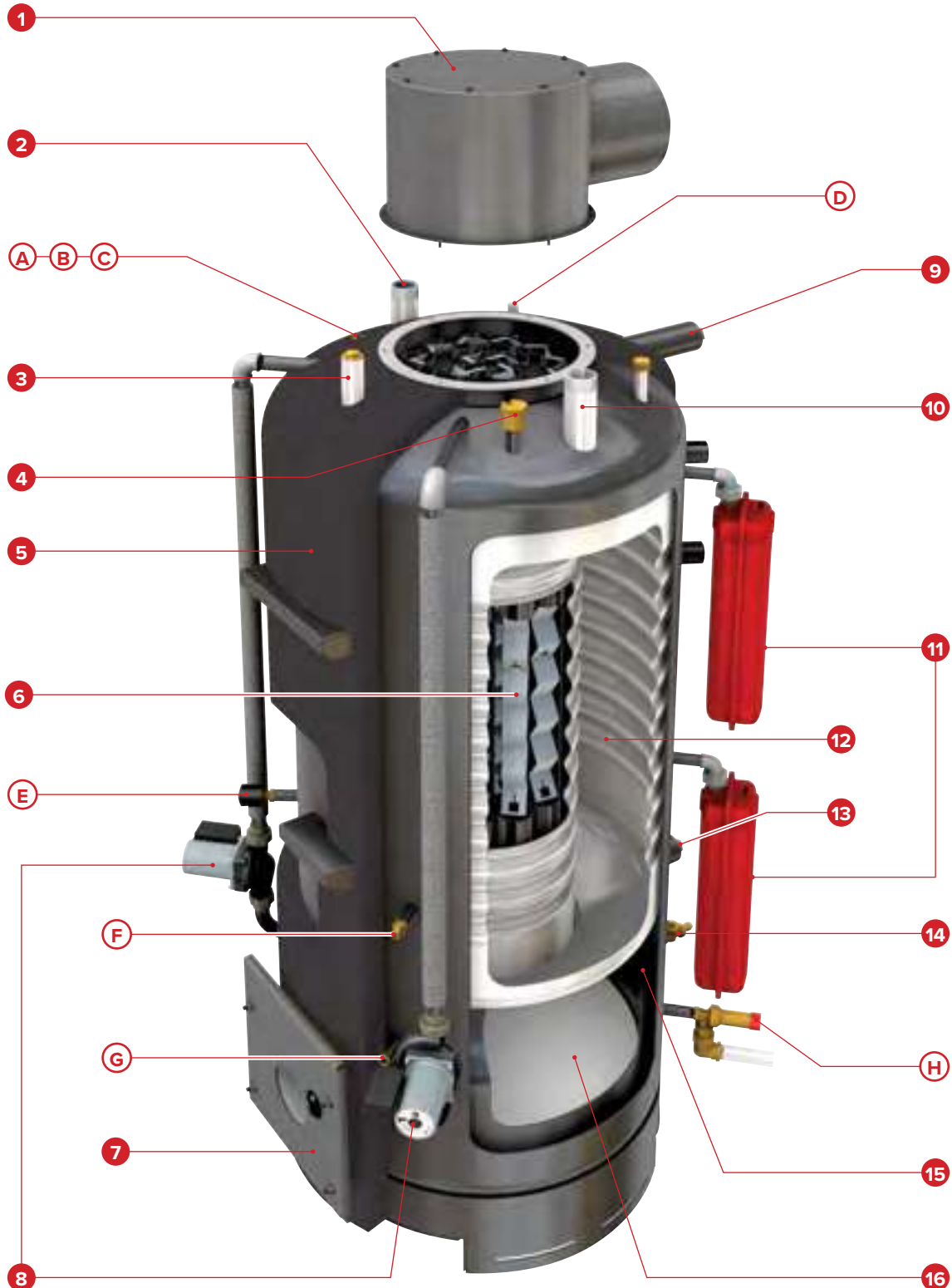

DIMENSIONS

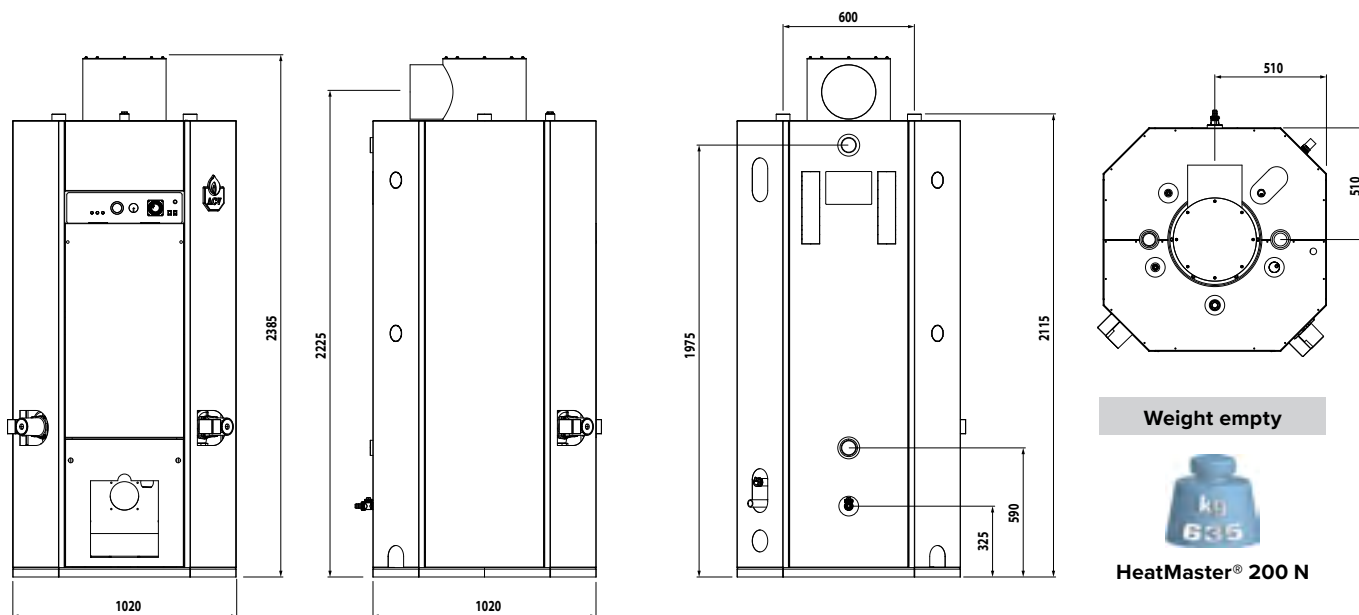

Weight empty



HeatMaster® 200 N

Weight empty



HeatMaster® 200 F

BURNER CHAMBER PLATE

The burner chamber plate has four threaded holes (M8) to attach the burner. It is protected from heat by a blanket insulation.

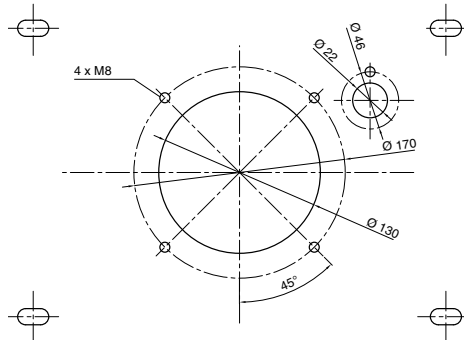

BOILER CLEARANCE

	Recommended	Minimum
A (mm)	650	500
B (mm)	800	700
C (mm)	500	300
D (mm)	300	250
E (mm)	150	100
F (mm)	800	700

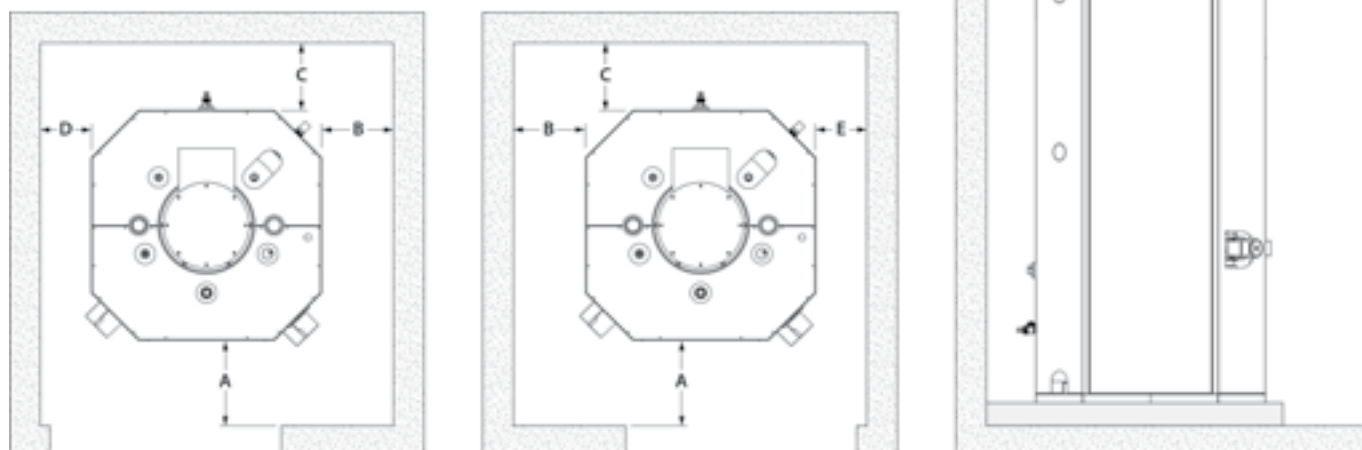

COMBUSTION CHARACTERISTICS

HEATMASTER®		HeatMaster® 200 N	HeatMaster® 200 F
Fuel	Type	Oil/Gas	Oil
Input max. (PCI)	kW	154	196
Output max. (80/60°C)	kW	142	180
Maintenance loss at 60°C as % of rated value	%	0,43	0,34
Efficiency (max output) 80/60°C	%	92,0	92,0
Combustion efficiency at 100%	%	—	93,1
Class NOx		—	5

HYDRAULIC CHARACTERISTICS

		HeatMaster® 200 N	HeatMaster® 200 F
Heating Connection [F]	Ø	2"	2"
DHW Connection [M]	Ø	2"	2"
Primary circuit water pressure drop ($\Delta T = 20K$)	mbar	118	190
Total capacity	L	641	641
Primary circuit capacity	L	241	241

DOMESTIC HOT WATER PERFORMANCE *

OPERATING CONDITIONS AT 90°C		HeatMaster® 200 N	HeatMaster® 200 F
Peak flow at 40°C [$\Delta T = 30 K$]	L/10'	1570	1675
Peak flow at 45°C [$\Delta T = 35 K$]	L/10'	1350	1444
Peak flow at 40°C [$\Delta T = 30 K$]	L/60'	4920	5976
Peak flow at 45°C [$\Delta T = 35 K$]	L/60'	4221	5131
Constant flow at 40°C [$\Delta T = 30 K$]	L/h	4020	5161
Constant flow at 45°C [$\Delta T = 30 K$]	L/h	3446	4424
Heating time from 10 to 80°C	minutes	29	27

*** For DHW temperatures > 45°C ($\Delta T > 35K$), please contact ACV



The temperature of the domestic hot water can be adjusted up to 90 °C in the boiler. However, the temperature of the domestic hot water at the drawing point must comply with local regulations. For special applications, please contact ACV.

BURNER

All the HeatMaster® 200 N boilers can be equipped with an oil or gas burner available on the market.

The HeatMaster® 200 F is factory delivered with a Riello RG4S oil burner.

MAXIMUM OPERATING CONDITIONS

Maximum Service Pressure (DHW tank full of water)

- Primary circuit..... 0,3 MPa (3 bar)
- DHW circuit..... 0.86 MPa (8.6 bar)

Maximum Operating Conditions

- Maximum temperature of primary fluid 90 °C
- Minimum temperature of primary fluid 60 °C

Water Quality

- Chlorides ≤ 150 mg/l (304)
- $6 \leq \text{pH} \leq 8$

CHIMNEY CONNECTION CHARACTERISTICS

		HeatMaster® 200 N	HeatMaster® 200 F
Volume of the combustion chamber	m ³	0,14	0,14
Mass flow rate of combustion products	g/s	—	83,0
Max. pressure drop in flue pipe	Pa	130	170
Flue pipe diameter	mm	250	250
Net temperature	°C	143	147,5
B23		✓	✓

BOILER ROOM

- make sure that all air vents are unobstructed at all times.
- do not store any flammable products in the boiler room.
- do not store any corrosive products, paint, solvents, salts, chloride products and other detergent products near the appliance.
- if you smell gas, do not switch on or off any lights, turn off the gas meter, ventilate the rooms and contact your installer.
- The base on which the boiler rests must be made of non-combustible materials.



Due to the high efficiency of our boilers, the flue gases are released at low temperature. As a result, there is a risk of condensation of the flue gases, which could damage some chimney constructions; to avoid this risk, it is strongly recommended to line the chimney. To prevent condensates to flow back into the boiler, we strongly advise to install a condensates collector. Please contact your installer for more information.

CHIMNEY CONNECTION

- Chimney connection must comply with the applicable standards (NBN D51-003 in Belgium), and take into account the local requirements of the energy provider, the fire requirements and the regulation on "noise pollution".
- The flue pipe size must not be smaller than the size of the boiler outlet connection

B23 type chimney connection

The boiler is connected to the chimney by a metal pipe rising at an angle from the boiler to the chimney. A flue disconnection piece is required.

It must be easily removable to give access to the flue pipes when performing boiler maintenance.

Minimum supply of fresh air into the boiler room

		Fresh air supply	
		Haute = A	Basse = B
HeatMaster® 200 N	cm ²	≥ 250	≥ 500
HeatMaster® 200 F	cm ²	≥ 250	≥ 600

Dimensions of a B23 type chimney

		Height = L		
		5 m	10 m	15 m
HeatMaster® 200 N	Ø mm	300	250	250
HeatMaster® 200 F	Ø mm	320	270	250

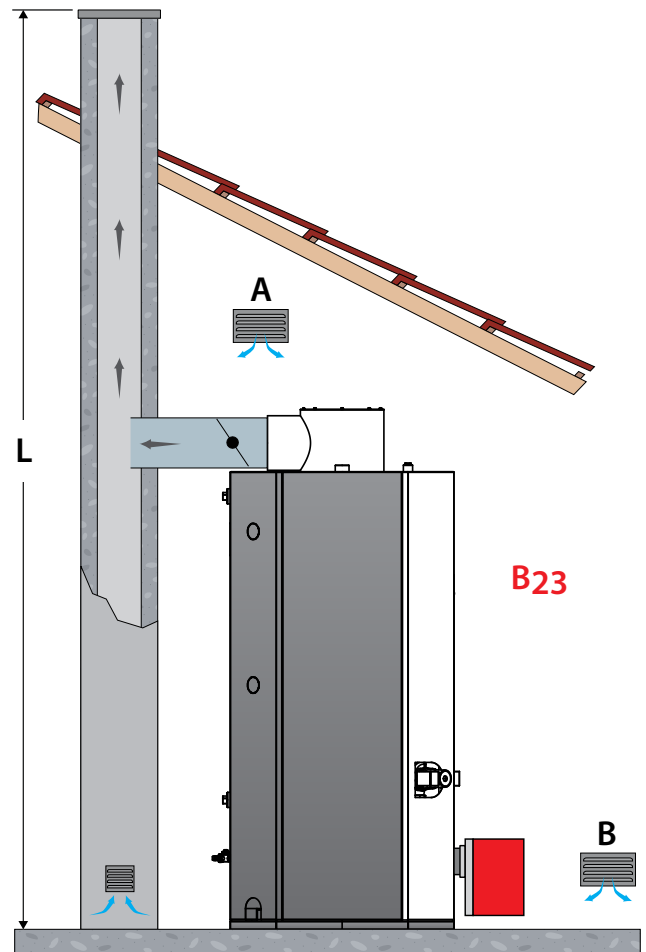

Note: Given that regulations vary from one country to another, the table above is given by way of indication only.

ELECTRICAL CHARACTERISTICS

WIRING DIAGRAM

1. 230 Volt electrical supply connection plug
2. Master switch
3. High limit thermostat indicator
4. Manual reset high limit thermostat
5. Low primary water pressure indicator
6. Low water pressure switch
7. Daily timer
8. Summer/winter switch
9. DHW priority thermostat
10. Burner safety cutout warning indicator
11. Room temperature (option))
12. Heating pump (option)
13. Charging pump **HeatMaster**[®]
14. Burner
15. Flow rate sensor (option)
16. Automatic reset high limit thermostat (95°C)
17. Control thermostat

MAIN ELECTRICAL CHARACTERISTICS

HeatMaster [®]		200 N	200 F
Operating voltage	V [~]	230	230
Rated frequency	Hz	50	50
Electrical consumption	W	425	815
Electrical power requirements	A	1,8	3,5
Protection IP		IP30	IP30



Make sure that the appliance is connected to the earth.

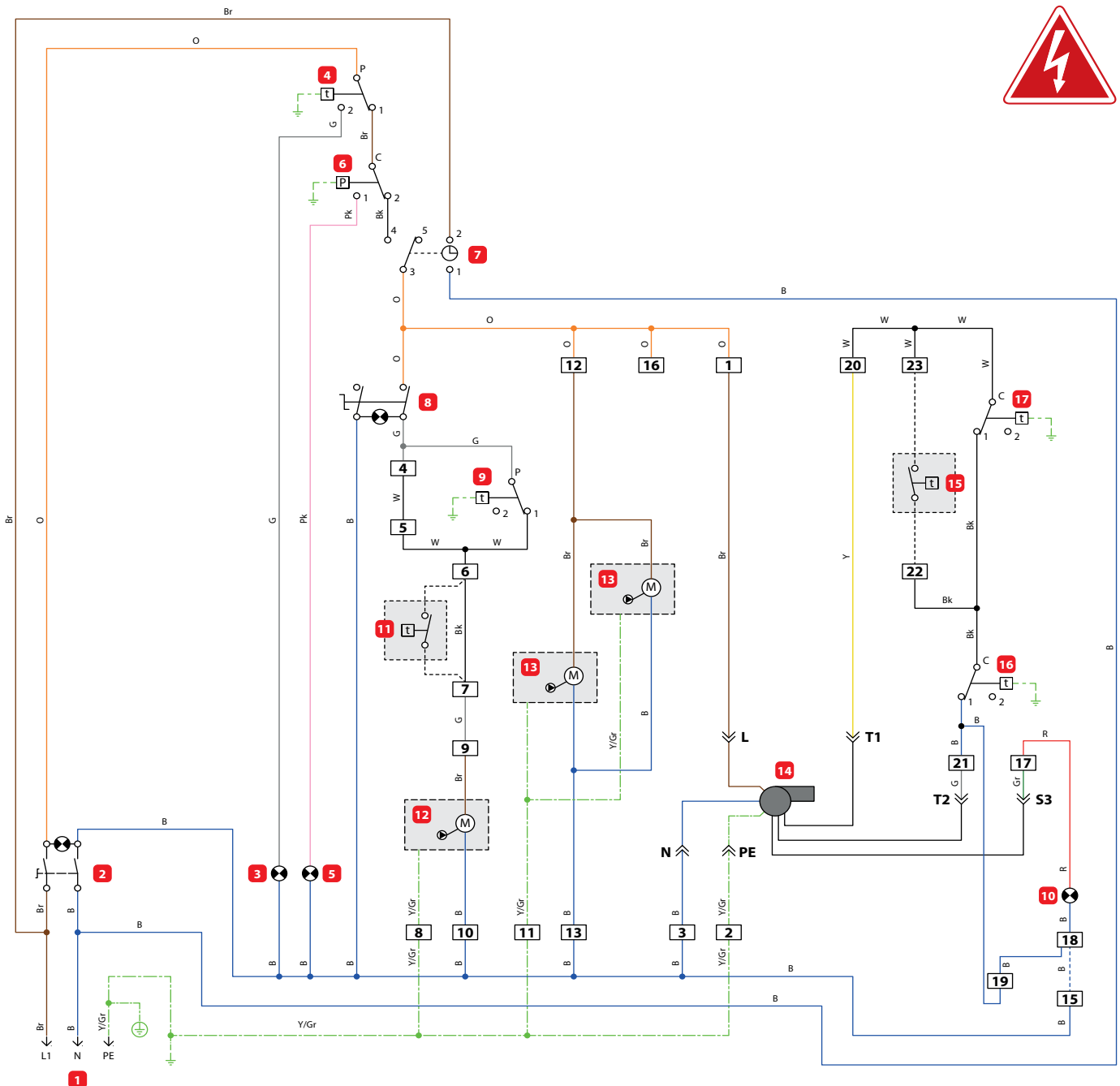

B. Blue
Bk. Black
Br. Brown

G. Grey
Gr. Green
O. Orange

Pk. Pink
R. Red
W. With

Y. Yellow
Y/Gr. Yellow / Green

PACKAGE CONTENTS

The appliances are delivered in 3 or 4 packages, tested and packaged separately on a wooden support, protected by anti-shock corner pieces and wrapped in a plastic film.

At product reception and after removal of packaging, check the package contents and that the components are free of damage..

Package contents N° 1 - [516 kg]

- A **HeatMaster®** boiler
- Installation, Operation and Maintenance Instructions
- A hydraulic kit, comprised of:
 - A primary safety valve Ø 3/4" F
 - A stainless steel pipe Ø 1"
 - A brass elbow union 90° - Ø 1"
 - A draining valve Ø 3/4" M
 - Silicone hose Ø 12x16 mm of 2,7 meters



Package contents N° 2 - [103 kg]

- A steel casing

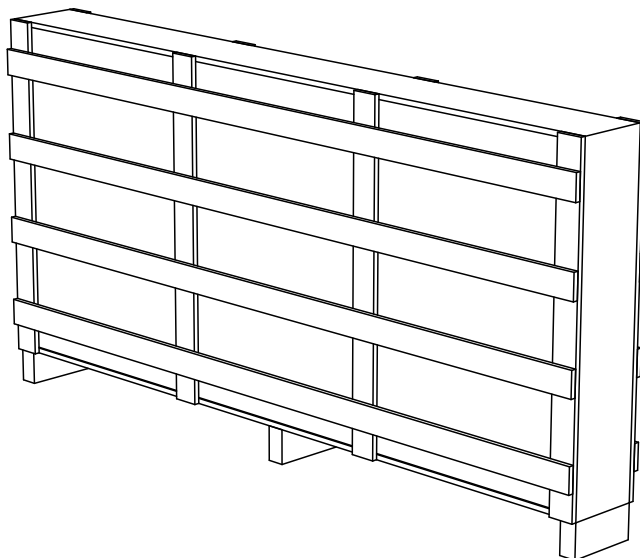

Package contents N° 3 - [10 kg]

- A chimney reduction with horizontal outlet
- A gasket for the flue reduction collar

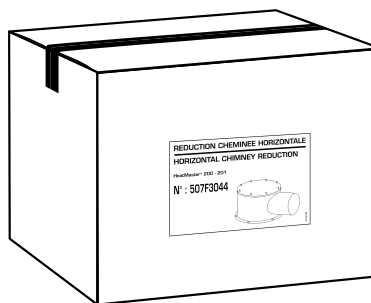

Package contents N° 4 (only for the HeatMaster® 200 F) - [20 kg]

- A **Riello** RG4S oil burner
- Technical instructions

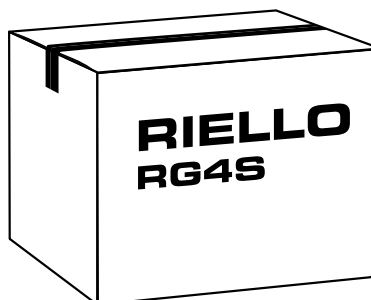

DHW CONNECTION



The DHW tank must be pressurized before putting the primary circuit (heating) under pressure.

The **HeatMaster®** boiler can be connected directly to the DHW circuit.

Flush the system before connecting the domestic hot water circuit.

The installation must be fitted with an approved safety group, comprised of a 0.7 MPa (7 bar) safety valve, a check valve and a shut-off valve.

During the heating process, the domestic hot water expands and the pressure increases. As soon as the pressure exceeds the safety valve setting, the valve opens and discharges a small quantity of water. Using a hot water expansion vessel (2 liters at least) will prevent this phenomenon and reduce the water hammer effect.



The hot water output may reach temperatures in excess of 60°C, which can cause burns.

ACV therefore recommends that you install a thermostatic mixing valve immediately after the appliance outlet.



If stop valves are used in the domestic hot water system, they can cause pressure changes when closed. Use devices designed to reduce water hammer effect to avoid this phenomenon.



If there is a risk of low pressure in the hot water circuit (installation of HeatMaster® on the roof of a building), it is essential to install a vacuum breaker device onto the cold water supply.

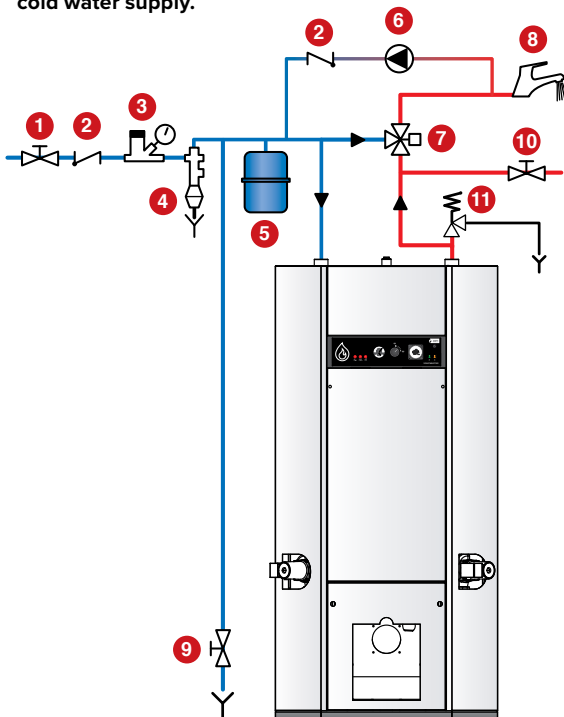

1. Cold water supply valve
2. Check valve
3. Pressure reducing valve
4. Domestic hot water safety valve set at 0.7 MPa (7 bar)
5. DHW circuit expansion vessel
6. DHW secondary pump (if fitted)
7. Thermostatic mixing valve
8. Draw-off tap
9. Draining valve
10. Stop valve for cleaning
11. Temperature relief valve (UK only)

EXAMPLE OF PARALLEL CONNECTION

Recommended for applications with a high constant flow.

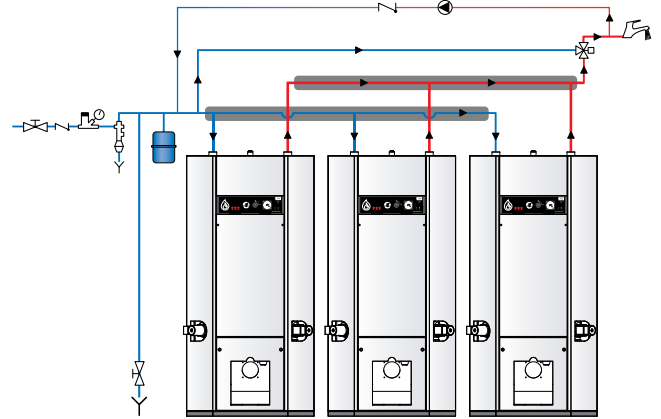

EXAMPLE OF SERIES CONNECTION

Preferable for high-temperature applications with up to 3 units

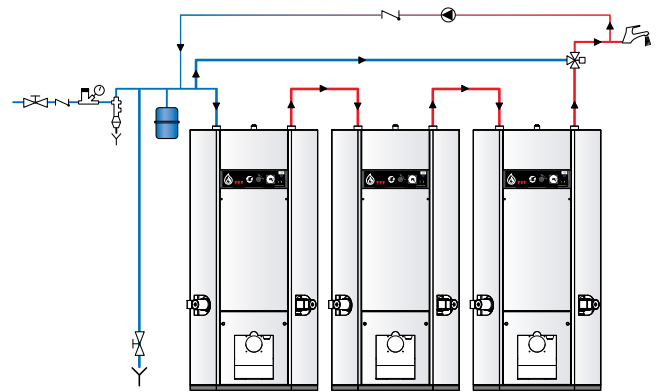

EXAMPLE OF HEATING + STORAGE CONNECTION

Recommended for applications requiring a high peak flow.

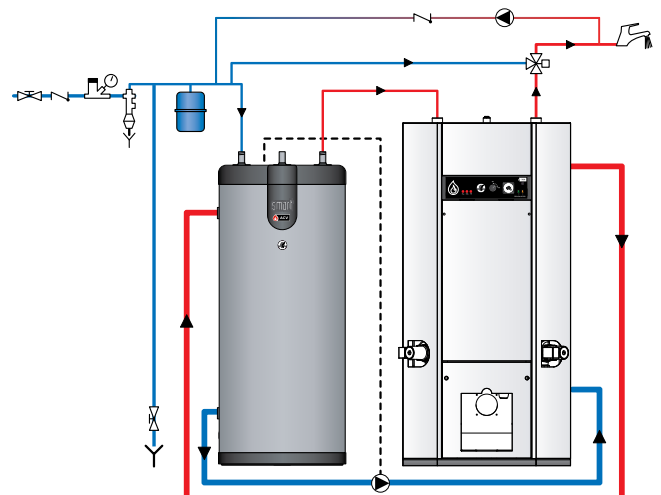

HEATING CONNECTION



The DHW tank must be pressurized before putting the primary circuit (heating) under pressure.

Two couplings are installed at the back of the **HeatMaster®**, that can be used to connect a central heating circuit. Connecting a heating system may reduce the domestic hot water performance.

EXPANSION VESSEL

The **HeatMaster®** 200 models are equipped with four 8 litre expansion vessels.

The expansion vessels are sized only for the "hot water" function. In the case of primary circuit connection, it is necessary to calculate the expansion capacity necessary for the total heating system volume (Refer to the expansion vessel manufacturer's technical instructions for a broader explanation).



The pressure of the **HeatMaster®** expansion tanks must be adjusted to the same pressure as the heating circuit expansion tanks.



WARNING

The primary safety valve is supplied with a plastic tube connected to discharge outlet - this is for test purposes only and should be removed. The safety valve should be connected to the sewer using a metallic pipe, e.g. copper.

1. 4-way mixing valve
2. Heating pump
3. Check valve
4. Heating circuit isolating valves
5. Safety valve set at 0.3 MPa (3 bar) with pressure gauge
6. Drain valve
7. Primary circuit filling valve
8. Controller
9. Contact sensor
10. Room thermostat
11. Outdoor temperature sensor

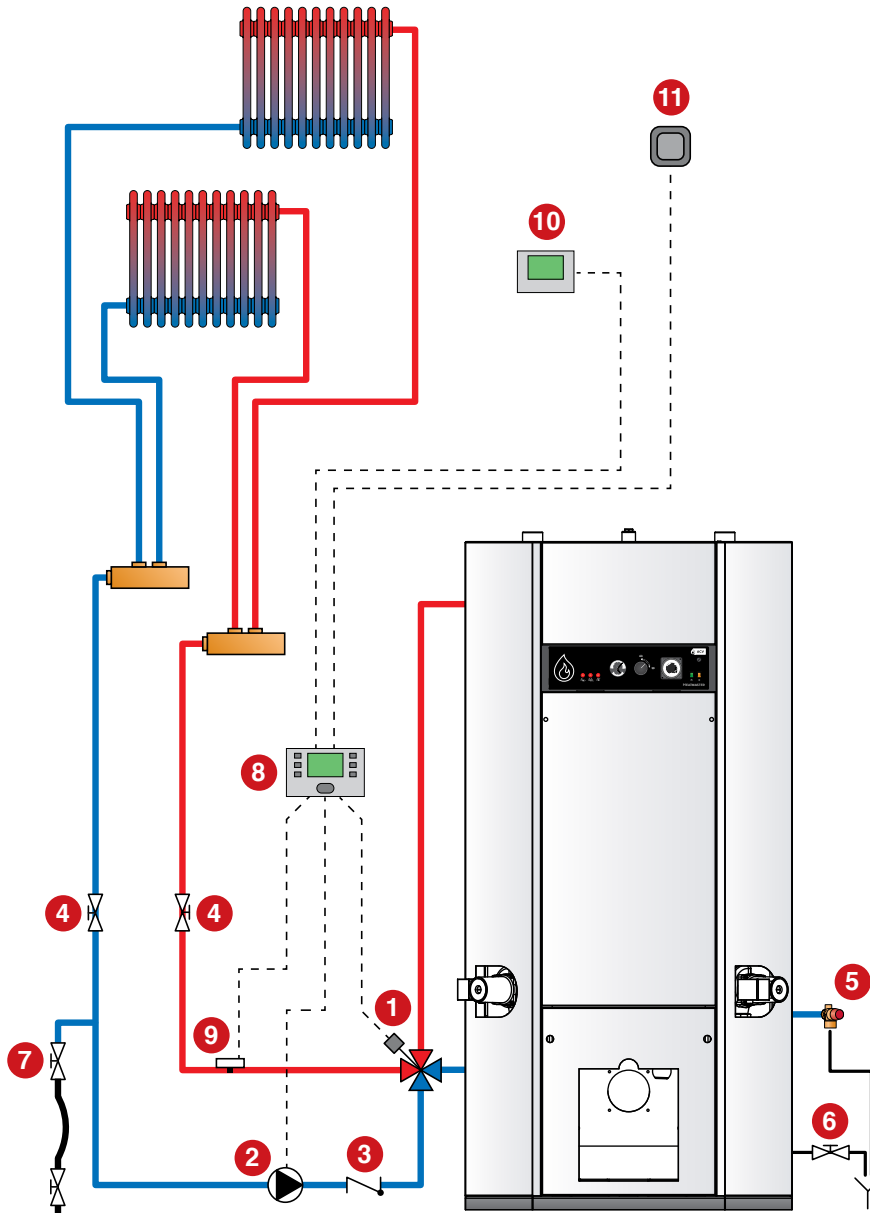

FILLING THE DOMESTIC HOT WATER AND HEATING CIRCUITS



IMPORTANT

Before pressurizing the central heating circuit, you should first put the domestic hot water tank under pressure.

FILLING THE DOMESTIC HOT WATER CIRCUIT

1. Open the filling valve **1** and the drawoff tap **2**.
2. When water flows out of the tap, the hot water tank is full and the drawoff tap **2** should be closed.

PRELIMINARY FILLING OF THE HEATING CIRCUIT

1. Open the stop valves **A**.
2. Make sure that the draining valve **D** is fully closed.
3. Open the filling valves **B** and **C** to start filling the primary circuit with mains water until you reach an approximate pressure of 0.15 MPa (1.5 bar) in the system.
4. Bleed the boiler and the whole system using the automatic air bleed valve located on top of the appliance.

STARTING UP THE BOILER

STARTING THE BURNER

1. Set the boiler master switch on "ON" and the summer/winter switch on the "❄️" symbol.
2. Rotate the boiler control thermostat clockwise to generate a heat demand.
3. Possibly increase the set temperature of the room thermostat, if installed.

ADJUSTING THE COMBUSTION

1. Refer to the starting up instructions detailed in the technical manual of the burner.
2. Adjust CO₂ as described in the Starting up paragraph of the burner.
3. Check temperatures and CO level.

BLEEDING THE HEATING CIRCUIT

1. Bleed the heating circuit again to restore a 0.15 MPa (1.5 bar) pressure.
2. Repeat the sequence until complete evacuation of the air contained in the circuit.

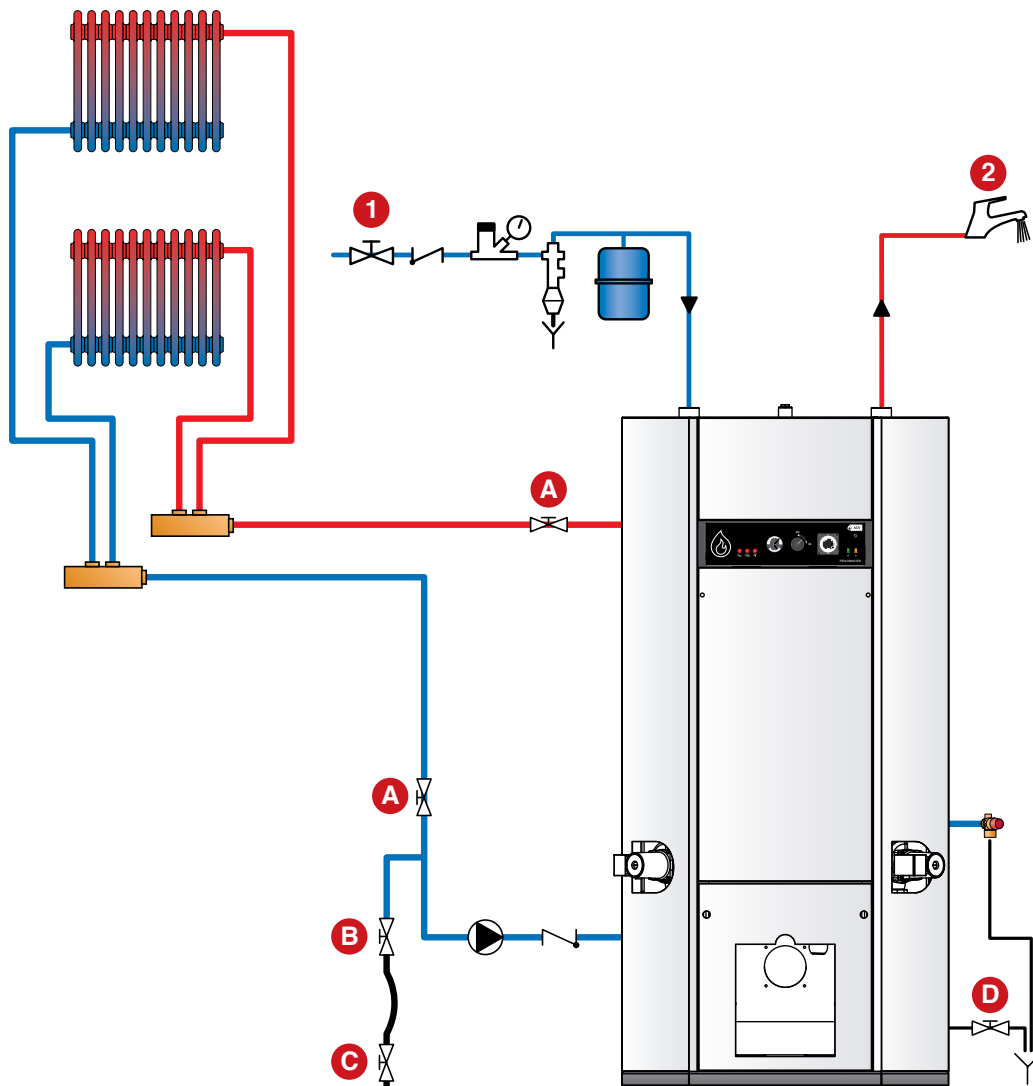

ANNUAL MAINTENANCE

ACV recommends the boilers should be serviced at least once a year. Maintenance and the burner control must be performed by a qualified engineer.

More frequent servicing may be required depending on boiler use. If this is the case, consult your installer for advice.

BOILER MAINTENANCE

1. Put the master switch on the control panel on "OFF" and isolate power supply to the unit.
2. Turn off the gas or oil supply to the boiler.

• Vertical flue gas outlet reduction:

3. Disengage and remove the flue connection to the boiler
4. Remove the flue reducer by un-tightening the nuts.
5. Extract the turbulators from the flue gas tubes for cleaning.
6. Dismantle the fire door and withdraw the burner.
7. Brush the flue gas tubes.
8. Clean the combustion chamber and the burner.
9. Replace the turbulators, chimney reduction and flue connection, and check that the seal on the flue reducer is in good condition. Replace the seal if necessary.

• Horizontal flue gas outlet reduction:

3. Remove the cover from the flue reducer by un-tightening the nuts.
4. Extract the turbulators from the flue gas tubes for cleaning.
5. Dismantle the fire door and withdraw the burner.
6. Brush the flue gas tubes.
7. Clean the combustion chamber and the burner.
8. Replace the turbulators, chimney reduction and flue connection, and check that the seal on the flue reducer is in good condition. Replace the seal if necessary.

MAINTENANCE OF THE SAFETY DEVICES

- Check that all thermostats and safety devices are working properly.
- Test the safety valves on the central heating and hot water circuits.

BURNER MAINTENANCE

- Check that the insulation and seal of the fire door are in good condition - replace them if necessary.
- Check and clean the burner and the electrodes. Replace the electrodes if necessary (once a year for normal use).
- Check that the safety valves are in good working order.
- Check the combustion (CO₂, CO and burner pressure).

DRAINING THE BOILER



Water flowing out of the drain valve may be extremely hot and could cause severe scalding. Keep people away from discharge of hot water.

DRAINING THE HEATING CIRCUIT

1. Put the master switch of the control panel on OFF, isolate the external electrical supply and turn off the gas or oil supply to the boiler.
2. Close the isolating valves **4** or put manually the 4-way mixing valve **1** on "0".
3. Connect a hose to the draining valve **6**.
4. Open the draining valve **9** to empty the primary circuit.

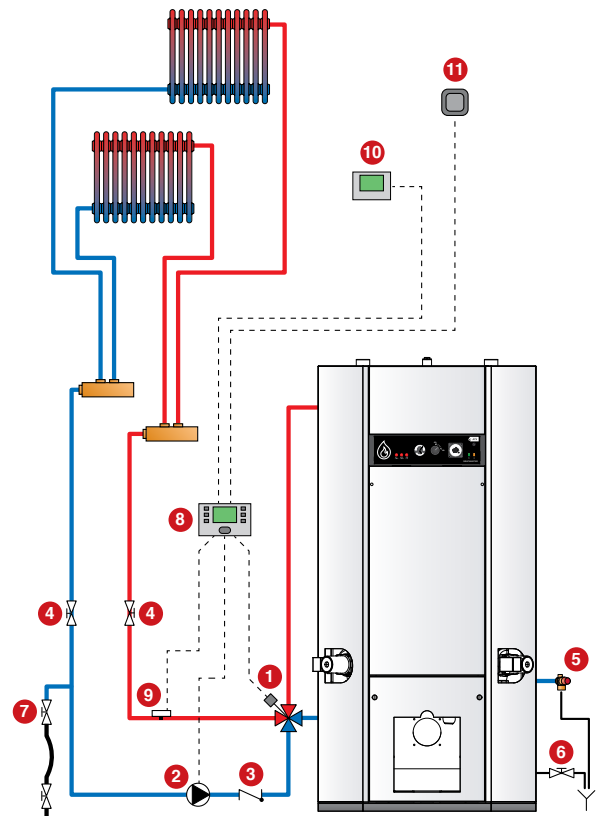

DRAINING THE DHW CIRCUIT

1. Put the master switch of the control panel on OFF, isolate the external electrical supply and turn off the gas or oil supply to the boiler.
2. Release the pressure in the heating circuit until the pressure gauge indicates 0 bar.
3. Close valves **1** and **8**.
4. Open valves **9** and **10** (first **9** then **10**).
5. Allow the drained water to flow into the sewer.



For the circuit to be drained, the draining valve **9** must be located at ground level.

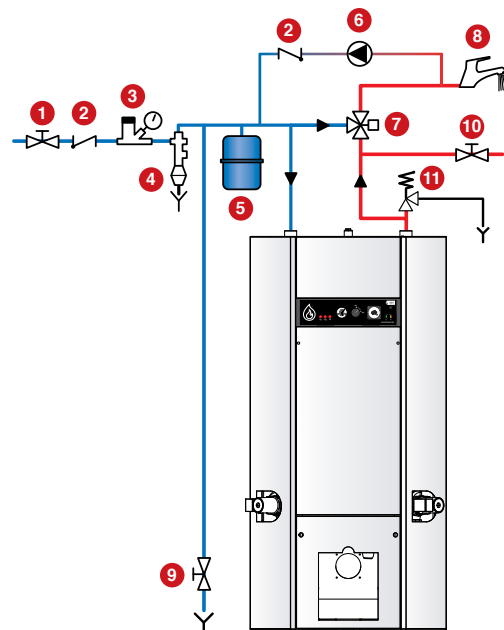



A BRAND OF



EU DECLARATION OF CONFORMITY

Product type: **Low temperature boiler
For Industrial Use Only**

Name and address of manufacturer: **Groupe Atlantic Manufacturing Belgium
Rue Henry Becquerel, 1
7180 Seneffe
Belgium**

This declaration of conformity is issued under the sole responsibility of the manufacturer.

Model: **HeatMaster 200 N
HeatMaster 200 F**

We declare hereby that the appliances specified above are conform to the following Regulations/Directives:

Regulation/ Directive	Description	Date
2006/42/EC	Machinery Directive	17.05.2006
2014/35/EU	Voltage Limits Directive	26.02.2014
2014/30/EU	Electromagnetic Compatibility Directive	26.02.2014
2021/0105	Regulation on Machinery	21.04.2021

Relevant harmonised standards :

EN 60335-2-102

EN 55014-1

EN 61000-3-2

EN 55014-2

EN 61000-3-3

**Signed for and on behalf of
Groupe Atlantic Manufacturing Belgium**

Seneffe, 01/01/2024

Date



R&D Director
Céline Coupain