

Statement of Compliance

Chauvin Arnoux®, Inc. d.b.a. AEMC® Instruments certifies that this instrument has been calibrated using standards and instruments traceable to international standards.

We guarantee that at the time of shipping your instrument has met its published specifications.

An NIST traceable certificate may be requested at the time of purchase, or obtained by returning the instrument to our repair and calibration facility, for a nominal charge.

The recommended calibration interval for this instrument is 12 months and begins on the date of receipt by the customer. For recalibration, please use our calibration services. Refer to our repair and calibration section at www.aemc.com.

Serial #: _____

Catalog #: 2129.83

Model #: 6292

Please fill in the appropriate date as indicated:

Date Received: _____

Date Calibration Due: _____



Chauvin Arnoux®, Inc.
d.b.a AEMC® Instruments
www.aemc.com

PRODUCT PACKAGING

Shipping Contents:



Micro-Ohmmeter Model 6292
Cat. #2129.83



Large Classic Tool Bag
Cat. #2133.71



USB Cable (5 ft)
Cat. #2140.46



Set of Two, 25 ft Kelvin Clips (200A - Hippo)
Cat. #2129.72



Power Cord, 110V US
Cat. #5000.40



USB Drive with
DataView® Software & User Manual













Green Ground Lead w/ Clamp
Cat. #2129.88

USB DRIVE: DataView® software and user manual for the Micro-Ohmmeter Model 6292 can be located on the USB drive supplied with the instrument.

Thank you for purchasing the AEMC Micro-Ohmmeter Model 6292.

For best results from your instrument and for your safety, read the enclosed operating instructions carefully and comply with the precautions for use. These products must be only used by qualified and trained users.

	WARNING, risk of DANGER! The operator must refer to these instructions whenever this danger symbol appears.
	CAUTION! Risk of electric shock. The voltage at the parts marked with this symbol may be dangerous.
	CAUTION! HOT SURFACE! The metallic parts close to this symbol may cause burn-related injuries.
	Application or withdrawal authorized on conductors carrying dangerous voltages. Type A current sensor as per IEC 61010-2-032.
	Must not be applied to or removed from conductors at dangerous voltages. Type B current sensor as per IEC 61010-2-032.
	Equipment is protected by double insulation.
	Battery
	Important instructions to read and to fully understand.
	Useful information or tip to read.
	The CE marking guarantees conformity with European directives and with regulations covering EMC.
	The trash can with a line through it means that in the European Union, the product must undergo selective disposal for the recycling of electric and electronic material, in compliance with Directive WEEE 2002/96/EC.

Definition of Measurement Categories (CAT)

CAT IV Measurement category IV corresponds to measurements taken at the source of low-voltage installations.

Example: power feeders, counters and protection devices.

CAT III Measurement category III corresponds to measurements on building installations.

Example: distribution panel, circuit-breakers, machines or fixed industrial devices.

CAT II Measurement category II corresponds to measurements taken on circuits directly connected to low-voltage installations.

Example: power supply to domestic electrical appliances and portable tools.

Precautions for Use

The protection obtained by the instrument can be compromised if it is used in a way that is not recommended by the manufacturer.

- Do not attempt to perform any tests with this instrument until you have read the user manual.
- Tests are to be carried out on de-energized circuits only! Never connect the unit to a live circuit.
- The micro-ohmmeter must be connected to the earth/ground point, through the ground terminal or the power cord.
- Be sure the power cord is accessible at all times, in case the instrument needs to be quickly unplugged for any reason. Always disconnect the power cord before performing any repair on the instrument.
- Do not obstruct either the intake vents or the fan, to avoid overheating.
- During a circuit breaker measurement its contacts must be closed and connected to an earth/ground point. The end connected to an earth/ground point must be connected to the “C-” terminal.
- Ensure the terminals are free of any voltage in relation to earth/ground point and between each other. Take into account that in a substation you will find, in disconnected points, high potential levels in relation to the earth/ground point. Those potentials are caused by presence of electromagnetic fields and can be minimized following the indications in the paragraph before.
- Make sure that the current connections are well connected to avoid undesirable heating.
- Be careful when manipulating the current terminals in the instrument. High temperatures may occur in the current connections.
- Never connect or disconnect the cables during a measurement. If a modification must be made, press the STOP button first.
- The micro-ohmmeter should never be used in an explosive environment (this includes poorly ventilated battery rooms and enclosures).
- The instrument, test leads and measuring wires must be free of defects and should be changed if there is any evidence of deterioration (insulation split, burnt, etc.).
- Never exceed the safety values indicated in the specifications.

Control Features

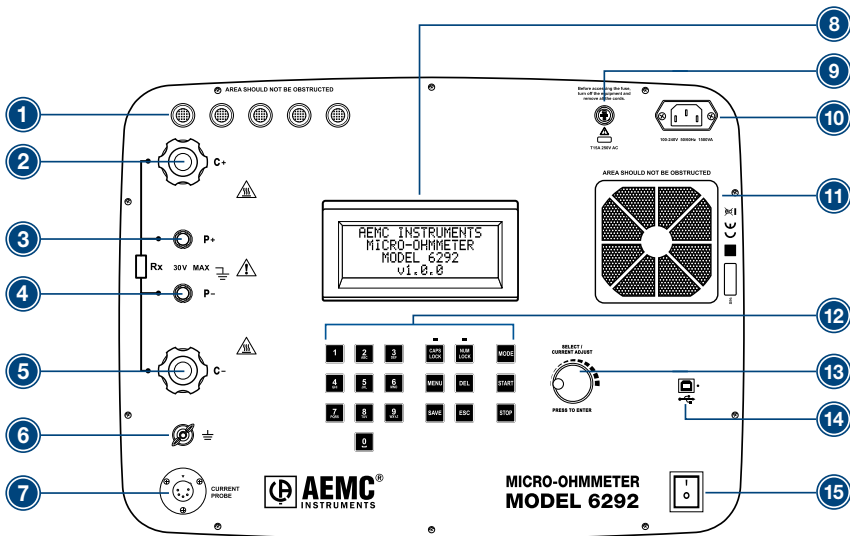

- | | |
|---------------------------------|--|
| 1. Air intake vents | 9. Fuse |
| 2. Current output terminal (C+) | 10. Power cord connector |
| 3. Potential terminal (P+) | 11. Fan |
| 4. Potential terminal (P-) | 12. Alphanumeric keypad and function buttons |
| 5. Current output terminal (C-) | 13. Rotary test knob |
| 6. Ground terminal | 14. USB communication port |
| 7. Current probe connector | 15. ON/OFF switch |
| 8. LCD Display | |

Current Probe Connector

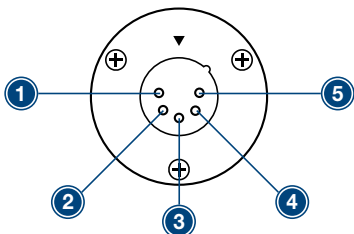

1. Positive supply for the current probe (+9VDC)
2. Negative supply for the current probe (Gnd)
3. Not connected
4. Current probe output signal (+)
5. Current probe output signal (-)

NOTE: The positive supply can supply 80mA maximum.

Keypad and Function Buttons

The Model 6292 can be operated and configured using the alphanumeric keypad. The keypad enables you to name objects (groups of tests) and enter the date/time, and the function buttons let you select a number of configuration settings.

The function buttons perform as follows:

- **CAPS LOCK** when enabled (indicated by a green LED just above it) results in all typed letters appearing capitalized on the display.
- **NUM LOCK** when enabled causes the keypad to print numbers vs. letters.
- **MENU** displays the main menu for configuration and instrument settings.
- **DEL** erases characters.
- **SAVE** saves the configuration or advances one menu level.
- **ESC** aborts some functions or returns back one menu level.
- **MODE** selects between Normal or BSG (both sides grounded) modes.
- **START** starts a test.
- **STOP** stops a test.

Rotary Knob

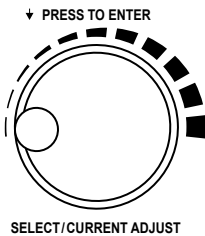

The rotary knob has two primary purposes: (1) adjust the current during a test, and (2) navigate through menus and select options.

- When the main screen is displayed, a short press will perform the MENU button function.
- When in a menu, rotating the knob navigates through listed options; a short press selects the highlighted option.
- When in a menu, pressing the rotary knob for two seconds performs an ESC button function.

During a fixed current test, a short press will allow manual adjustment of the test current.

Installing DataView®



DO NOT CONNECT THE INSTRUMENT TO THE PC BEFORE INSTALLING THE SOFTWARE AND DRIVERS.

1. Insert the USB stick into an available USB port (wait for driver to be installed).
2. If Autorun is enabled, an AutoPlay window should appear. If Autorun is disabled, it will be necessary to open Windows Explorer, then locate and open the USB stick drive labeled **DataView** to view the files on the drive.
3. In the AutoPlay window, select **Open folder to view files**.
4. Double-click on **Setup.exe** from the opened folder view to launch the DataView® setup program.

NOTE: For more information on using the DataView® software, refer to the Model 6292 user manual that is supplied on the USB stick.

Getting Started



WARNING: Read the user manual and safety warnings before using this instrument. Safety procedures and rules for working near high voltage energized systems must be observed during the use of this instrument. The generated voltages and currents may be dangerous.

1. Connect the instrument to a 120/240V 50/60Hz AC power supply.
2. Perform a test with the test leads shorted. If the current does not reach the preset current (or the measured resistance is significantly higher than 0Ω), check the connection and try again. If the problem persists, contact technical assistance.
3. Before turning the instrument on, connect the test probes to the device to be tested and to the appropriate front panel terminals.

Connection Example in BSG Mode:

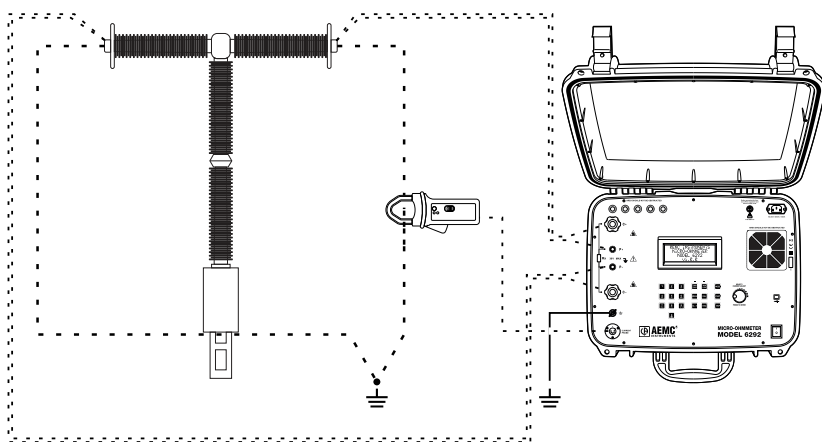

WARNING: Do not connect or disconnect the test leads during a measurement. Grounding connections are strongly recommended to protect the operator and equipment. Use a strong grounding point as close as possible to the device under test. This ground is required to verify the instrument is working properly.

Saving a Test

- To save a test result, press **SAVE** during the test to get partial results or at the end of the test to save the final result.
- If the Auto Save function in the menu settings is set to ON, the final result will be automatically saved at each successfully completed test.

Establishing Communication to the Instrument

1. Connect the instrument to the PC with the supplied cable.
2. Double-click the **Micro-Ohmmeter icon** in the DataView folder that was created on the desktop during software installation to open the Control Panel.
3. From the menu bar, select **Instrument**, then click **Connect** to open the Connection dialog box.

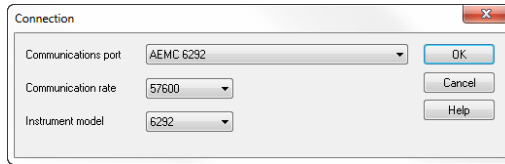

The instrument name should appear in the **Communication port** field. If not, select it from the drop-down list. Ensure that the **Instrument model** field is set to 6292, and the **Communication rate** is set to 57600. Then click **OK**.

Configuring the Instrument

Establish a connection to the instrument. Then from the menu bar, select **Instrument**, then click **Configure**. The Configuration Panel dialog box will appear:

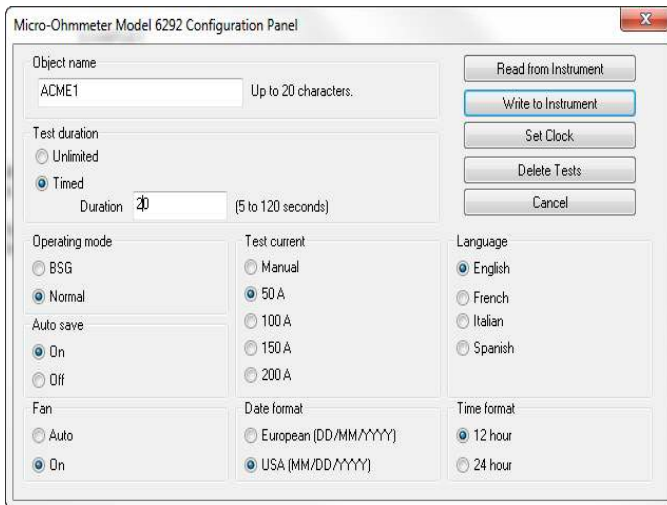

This dialog box allows you to configure options for each of the following settings:

- **Object name** is the name of the test object. This name can be up to 20 characters in length.
- **Test duration** determines how long the test will run. Selecting Unlimited will run the test until you manually stop it by pressing the **STOP** button on the instrument. Select Limited if you want the test to have a defined end point. When you choose this option, the Duration field activates so you can enter the number of seconds you want the test to run. The minimum is 5 seconds, the maximum is 120 seconds.
- **Operating mode** determines whether the test is run using BSG (both sides grounded) or Normal mode.

- **Test current** is the current to be used when running a test. Available settings are 50, 100, 150, or 200A. You can also select Manual to use the rotary knob on the instrument to control the current level during the test.
- **Language** specifies the language to be used by the instrument's display.
- **Auto Save** specifies whether or not a test is automatically saved at the time it is performed.
- **Fan** defines whether the fan is always on or runs in Auto mode (only turns on when the instrument needs to cool its internal temperature).
- **Date format** selects the format of dates to be used by the instrument (European or USA).
- **Time format** specifies whether the time is to be displayed using a 12 hour (AM/PM) or a 24 hour clock.

On the right side of the Configuration Panel dialog box are five buttons:

- **Read from Instrument** resets the options in this dialog box to reflect the settings as they are set in the instrument.
- **Write to Instrument** writes the configuration settings to the instrument.
- **Set Clock** displays the Date/Time dialog box. This enables you to set the instrument's time to a specific date and time, or synchronize the instrument's clock with the PC's clock.
- **Delete Tests** erases the instrument's memory. Note that after you confirm that you want to proceed with the deletion; all objects are immediately removed from memory, irrespective of whether you save any other changes made through the Configuration Panel dialog box.
- **Cancel** closes this dialog box discarding any changes specified without writing them to the attached instrument.

Downloading Stored Tests

1. To download stored tests, select **Instrument** from the menu bar, then click **Download**. If a connection had not been previously established, the Connection dialog box will be displayed. Otherwise, the Select Tests dialog box will appear displaying a list of tests stored in the instrument.
2. Select the test you want to download by clicking it. You can select multiple tests by holding down the **Ctrl** key while clicking your selections. Click **Select All** to select all listed tests to download. After you have finished making selections, click the **Download** button.
3. To edit the name and other properties of the test, double-click on the test's name on the left side of the Control Panel.
4. Click on the desired test to download (hold the Ctrl key to select multiple tests), then click the **Download** button.
5. To edit the name and other properties of the test, double-click on the Test's name on the left side of the Control Panel.



NOTE: For complete operating instructions and more information on using DataView, refer to the product user manual that is supplied on the USB stick.

Repair and Calibration

To ensure that your instrument meets factory specifications, we recommend that it be scheduled to be shipped to our factory Service Center at one-year intervals for recalibration, or as required by other standards or internal procedures.

For instrument repair and calibration:

You must contact our Service Center for a Customer Service Authorization Number (CSA#). This will ensure that when your instrument arrives, it will be tracked and processed promptly. Please write the CSA# on the outside of the shipping container. If the instrument is returned for calibration, we need to know if you want a standard calibration, or a calibration traceable to N.I.S.T. (which includes calibration certificate plus recorded calibration data).

Ship To: Chauvin Arnoux®, Inc. d.b.a. AEMC® Instruments
15 Faraday Drive, Dover NH 03820 USA
Phone: (800) 945-2362 (Ext. 360) • (603) 749-6434 (Ext. 360)
Fax: (603) 742-2346 or (603) 749-6309
E-mail: repair@aemc.com

Or contact your authorized distributor.

Costs for repair, standard calibration, and calibration traceable to N.I.S.T. are available.

NOTE: You must obtain a CSA# before returning any instrument.

Technical and Sales Assistance

If you are experiencing any technical problems, or require any assistance with the proper operation or application of your instrument, please call, fax or e-mail our technical support team:

Contact: Chauvin Arnoux®, Inc. d.b.a. AEMC® Instruments
Phone: (800) 945-2362 (Ext. 351) • (603) 749-6434 (Ext. 351)
Fax: (603) 742-2346
E-mail: techsupport@aemc.com

Limited Warranty

The Model 6292 is warranted to the owner for a period of two years from the date of original purchase against defects in manufacture. This limited warranty is given by AEMC® Instruments, not by the distributor from whom it was purchased. This warranty is void if the unit has been tampered with, abused or if the defect is related to service not performed by AEMC® Instruments.

Full warranty coverage and registration is available on our website: www.aemc.com/warranty.html

Please print the online Warranty Coverage Information for your records.

What AEMC® Instruments will do:

If a malfunction occurs within the warranty period, you may return the instrument to us for repair, provided we have your warranty registration information on file or a proof of purchase. AEMC® Instruments will, at its option, repair or replace the faulty material.

Warranty Repairs

What you must do to return an Instrument for Warranty Repair: First, request a Customer Service Authorization Number (CSA#) by phone or by fax from our Service Department (see address below), then return the instrument along with the signed CSA Form. Please write the CSA# on the outside of the shipping container. Return the instrument, postage or shipment pre-paid to:

Ship To: Chauvin Arnoux®, Inc. d.b.a. AEMC® Instruments
15 Faraday Drive, Dover NH 03820 USA
Phone: (800) 945-2362 (Ext. 360) • (603) 749-6434 (Ext. 360)
Fax: (603) 742-2346 or (603) 749-6309
E-mail: repair@aemc.com

NOTE: You must obtain a CSA# before returning any instrument.



01/18
99-MAN 100394 v8

Chauvin Arnoux®, Inc. d.b.a. AEMC® Instruments
15 Faraday Drive • Dover, NH 03820 USA • Phone: (603) 749-6434 • Fax: (603) 742-2346
www.aemc.com