

Installation Instructions

Original Instructions



Allen-Bradley

by ROCKWELL AUTOMATION

POINT I/O 4 Channel IO-Link Master Module

Catalog Numbers 1734-4IOL, 1734-4IOLK, Series B

Catalog numbers with the suffix 'K' are conformal coated and their specifications are the same as non-conformal coated catalogs.

| Topic | Page |
|--------------------------------------|------|
| Summary of Changes | 1 |
| About the Module | 4 |
| Install the Mounting Base | 6 |
| Install the Module | 6 |
| Install the Removable Terminal Block | 7 |
| Wire the Module | 8 |
| Communicate with Your Module | 10 |
| Interpret Status Indicators | 11 |
| Specifications | 13 |

Summary of Changes

This publication contains the following new or updated information. This list includes substantive updates only and is not intended to reflect all changes.

| Topic | Page |
|---|------------|
| Updated UK and European Hazardous Location Approval | 3 |
| Added IEC Hazardous Location Approval | 4 |
| Updated Special Conditions for Safe Use | 4 |
| Updated About the Module | 4 |
| Updated Wire the Module | 9 |
| Updated General Specification | 12 |
| Updated Standard Digital Input specifications | 12 |
| Updated Standard Digital Output specifications | 13 |
| Updated Environmental Specifications | 13 |
| Updated Certifications | 13, 14 |
| Updated back cover | back cover |



ATTENTION: Read this document and the documents listed in the Additional Resources section about installation, configuration and operation of this equipment before you install, configure, operate or maintain this product. Users are required to familiarize themselves with installation and wiring instructions in addition to requirements of all applicable codes, laws, and standards.

Activities including installation, adjustments, putting into service, use, assembly, disassembly, and maintenance are required to be carried out by suitably trained personnel in accordance with applicable code of practice. If this equipment is used in a manner not specified by the manufacturer, the protection provided by the equipment may be impaired.

注意：在安装、配置、操作和维护本产品前，请阅读本文档以及“其他资源”部分列出的有关设备安装、配置和操作的相应文档。除了所有适用规范、法律和标准的相关要求之外，用户还必须熟悉安装和接线说明。

安装、调整、投运、使用、组装、拆卸和维护等各项操作必须由经过适当训练的专业人员按照适用的操作规范实施。

如果未按照制造商指定的方式使用该设备，则可能会损害设备提供的保护。

ATENCIÓN: Antes de instalar, configurar, poner en funcionamiento o realizar el mantenimiento de este producto, lea este documento y los documentos listados en la sección Recursos adicionales acerca de la instalación, configuración y operación de este equipo. Los usuarios deben familiarizarse con las instrucciones de instalación y cableado y con los requisitos de todos los códigos, leyes y estándares vigentes.

El personal debidamente capacitado debe realizar las actividades relacionadas a la instalación, ajustes, puesta en servicio, uso, ensamblaje, desensamblaje y mantenimiento de conformidad con el código de práctica aplicable. Si este equipo se usa de una manera no especificada por el fabricante, la protección provista por el equipo puede resultar afectada.

ATENÇÃO: Leia este e os demais documentos sobre instalação, configuração e operação do equipamento que estão na seção Recursos adicionais antes de instalar, configurar, operar ou manter este produto. Os usuários devem se familiarizar com as instruções de instalação e fiação além das especificações para todos os códigos, leis e normas aplicáveis.

É necessário que as atividades, incluindo instalação, ajustes, colocação em serviço, utilização, montagem, desmontagem e manutenção sejam realizadas por pessoal qualificado e especializado, de acordo com o código de prática aplicável.

Caso este equipamento seja utilizado de maneira não estabelecida pelo fabricante, a proteção fornecida pelo equipamento pode ficar prejudicada.

ВНИМАНИЕ: Перед тем как устанавливать, настраивать, эксплуатировать или обслуживать данное оборудование, прочитайте этот документ и документы, перечисленные в разделе «Дополнительные ресурсы». В этих документах изложены сведения об установке, настройке и эксплуатации данного оборудования. Пользователи обязаны ознакомиться с инструкциями по установке и прокладке соединений, а также с требованиями всех применимых норм, законов и стандартов.

Все действия, включая установку, наладку, ввод в эксплуатацию, использование, сборку, разборку и техническое обслуживание, должны выполняться обученным персоналом в соответствии с применимыми нормами и правилами.

Если оборудование используется не предусмотренным производителем образом, защита оборудования может быть нарушена.

注意：本製品を設置、構成、稼働または保守する前に、本書および本機器の設置、設定、操作についての参考資料の該当箇所に記載されている文書に目を通してください。ユーザーは、すべての該当する条例、法律、規格の要件に加えて、設置および配線の手順に習熟している必要があります。

設置調整、運転の開始、使用、組立て、解体、保守を含む諸作業は、該当する実施規則に従って訓練を受けた適切な作業員が実行する必要があります。

本機器が製造メーカーにより指定されていない方法で使用されている場合、機器により提供されている保護が損なわれる恐れがあります。

ACHTUNG: Lesen Sie dieses Dokument und die im Abschnitt „Weitere Informationen“ aufgeführten Dokumente, die Informationen zu Installation, Konfiguration und Bedienung dieses Produkts enthalten, bevor Sie dieses Produkt installieren, konfigurieren, bedienen oder warten. Anwender müssen sich neben den Bestimmungen aller anwendbaren Vorschriften, Gesetze und Normen zusätzlich mit den Installations- und Verdrahtungsanweisungen vertraut machen.

Arbeiten im Rahmen der Installation, Anpassung, Inbetriebnahme, Verwendung, Montage, Demontage oder Instandhaltung dürfen nur durch ausreichend geschulte Mitarbeiter und in Übereinstimmung mit den anwendbaren Ausführungsvorschriften vorgenommen werden.

Wenn das Gerät in einer Weise verwendet wird, die vom Hersteller nicht vorgesehen ist, kann die Schutzfunktion beeinträchtigt sein.

ATTENTION: Lisez ce document et les documents listés dans la section Ressources complémentaires relatifs à l'installation, la configuration et le fonctionnement de cet équipement avant d'installer, configurer, utiliser ou entretenir ce produit. Les utilisateurs doivent se familiariser avec les instructions d'installation et de câblage en plus des exigences relatives aux codes, lois et normes en vigueur. Les activités relatives à l'installation, le réglage, la mise en service, l'utilisation, l'assemblage, le démontage et l'entretien doivent être réalisées par des personnes formées selon le code de pratique en vigueur.

Si cet équipement est utilisé d'une façon qui n'a pas été définie par le fabricant, la protection fournie par l'équipement peut être compromise.

주의：본 제품 설치, 설정, 작동 또는 유지 보수하기 전에 본 문서를 포함하여 설치, 설정 및 작동에 관한 참고 자료 섹션의 문서들을 반드시 읽고 숙지하십시오. 사용자는 모든 관련 규정, 법규 및 표준에서 요구하는 사항에 대해 반드시 설치 및 배선 지침을 숙지해야 합니다.

설치, 조정, 가동, 조립, 분해, 유지보수 등 모든 작업은 관련 규정에 따라 적절한 교육을 받은 사용자를 통해서만 수행해야 합니다.

본 장비를 제조사가 명시하지 않은 방법으로 사용하면 장비의 보호 기능이 손상될 수 있습니다.

ATTENZIONE: Prima di installare, configurare ed utilizzare il prodotto, o effettuare interventi di manutenzione su di esso, leggere il presente documento ed i documenti elencati nella sezione "Altre risorse", riguardanti l'installazione, la configurazione ed il funzionamento dell'apparecchiatura. Gli utenti devono leggere e comprendere le istruzioni di installazione e cablaggio, oltre ai requisiti previsti dalle leggi, codici e standard applicabili.

Le attività come installazione, regolazioni, utilizzo, assemblaggio, disassemblaggio e manutenzione devono essere svolte da personale adeguatamente addestrato, nel rispetto delle procedure previste.

Qualora l'apparecchio venga utilizzato con modalità diverse da quanto previsto dal produttore, la sua funzione di protezione potrebbe venire compromessa.

DIKKAT: Bu ürünün kurulumu, yapılandırılması, işletilmesi veya bakımı öncesinde bu dokümanı ve bu ekipmanın kurulumu, yapılandırılması ve işletimi ile ilgili ilave Kaynaklar bölümünde yer listelenmiş dokümanları okuyun. Kullanıcılar yürürlükteki tüm yönetmelikler, yasalar ve standartların gereksinimlerine ek olarak kurulum ve kablolama talimatlarını da öğrenmek zorundadır.

Kurulum, ayarlama, hizmete alma, kullanma, parçaları birleştirme, parçaları sökme ve bakım gibi aktiviteler sadece uygun eğitimli almış kişiler tarafından yürürlükteki uygulama yönetmeliklerine uygun şekilde yapılabilir.

Bu ekipman üretici tarafından belirlenmiş amacın dışında kullanılırsa, ekipman tarafından sağlanan koruma bozulabilir.

注意事項：在安装、設定、操作或維護本產品前，請先閱讀此文件以及列於「其他資源」章節中所有有關安裝、設定與操作此設備的文件。使用者必須熟悉安裝和配線指示，並符合所有法規、法律和標準要求。

包括安裝、調整、交付使用、使用、組裝、拆卸和維護等動作都必須交由已經過適當訓練的人員進行，以符合適用的實作法規。

如果將設備用於非製造商指定的用途時，可能會造成設備所提供的保護功能受損。

POZOR: Než začnete instalovat, konfigurovat či provozovat tento výrobek nebo provádět jeho údržbu, přečtěte si tento dokument a dokumenty uvedené v části Dodatečné zdroje ohledně instalace, konfigurace a provozu tohoto zařízení. Uživatelé se musejí vedle požadavků všech relevantních vyhlášek, zákonů a norem nutně seznámit také s pokyny pro instalaci a elektrické zapojení.

Činnosti zahrnující instalaci, nastavení, uvedení do provozu, užívání, montáž, demontáž a údržbu musí vykonávat vhodné proškolený personál v souladu s příslušnými prováděcími předpisy.

Pokud se toto zařízení používá způsobem neodpovídajícím specifikaci výrobce, může být narušena ochrana, kterou toto zařízení poskytuje.

UWAGA: Przed instalacją, konfiguracją, użytkowaniem lub konserwacją tego produktu należy przeczytać niniejszy dokument oraz wszystkie dokumenty wymienione w sekcji Dodatkowe źródła omawiające instalację, konfigurację i procedury użytkowania tego urządzenia. Użytkownicy mają obowiązek zapoznać się z instrukcjami dotyczącymi instalacji oraz oprzewodowania, jak również z obowiązującymi kodeksami, prawem i normami.

Działania obejmujące instalację, regulację, przekazanie do użytkowania, użytkowanie, montaż, demontaż oraz konserwację muszą być wykonywane przez odpowiednio przeszkolony personel zgodnie z obowiązującym kodeksem postępowania.

Jeśli urządzenie jest użytkowane w sposób inny niż określony przez producenta, zabezpieczenie zapewniane przez urządzenie może zostać ograniczone.

OBBS! Läs detta dokument samt dokumentet, som står listat i avsnittet Övriga resurser, om installation, konfigurering och drift av denna utrustning innan du installerar, konfigurerar eller börjar använda eller utföra underhållsarbete på produkten. Användare måste bekanta sig med instruktioner för installation och kabeldragning, förutom krav enligt gällande koder, lagar och standarder.

Åtgärder som installation, justering, service, användning, montering, demontering och underhållsarbete måste utföras av personal med lämplig utbildning enligt lämpligt bruk.

Om denna utrustning används på ett sätt som inte anges av tillverkaren kan det hända att utrustningens skyddsanordningar försätts ur funktion.

LET OP: Lees dit document en de documenten die genoemd worden in de paragraaf Aanvullende informatie over de installatie, configuratie en bediening van deze apparatuur voordat u dit product installeert, configureert, bedient of onderhoudt. Gebruikers moeten zich vertrouwd maken met de installatie en de bedravingsinstructies, naast de vereisten van alle toepasselijke regels, wetten en normen.

Activiteiten zoals het installeren, afstellen, in gebruik stellen, gebruiken, monteren, demonteren en het uitvoeren van onderhoud mogen uitsluitend worden uitgevoerd door hiervoor opgeleid personeel en in overeenstemming met de geldende praktijkregels.

Indien de apparatuur wordt gebruikt op een wijze die niet is gespecificeerd door de fabrikant, dan bestaat het gevaar dat de beveiliging van de apparatuur niet goed werkt.

Environment and Enclosure



ATTENTION: This equipment is intended for use in a Pollution Degree 2 industrial environment, in overvoltage Category II applications (as defined in EN/IEC 60664-1), at altitudes up to 2000 m (6562 ft) without derating. This equipment is not intended for use in residential environments and may not provide adequate protection to radio communication services in such environments.

This equipment is supplied as open-type equipment for indoor use. It must be mounted within an enclosure that is suitably designed for those specific environmental conditions that will be present and appropriately designed to prevent personal injury resulting from accessibility to live parts. The enclosure must have suitable flame-retardant properties to prevent or minimize the spread of flame, complying with a flame spread rating of 5VA or be approved for the application if nonmetallic. The interior of the enclosure must be accessible only by the use of a tool. Subsequent sections of this publication may contain more information regarding specific enclosure type ratings that are required to comply with certain product safety certifications.

In addition to this publication, see the following:



- Industrial Automation Wiring and Grounding Guidelines, publication [1770-4.1](#), for additional installation requirements.
- NEMA Standard 250 and EN/IEC 60529, as applicable, for explanations of the degrees of protection provided by enclosures.



ATTENTION: Read this document and the documents listed in the Additional Resources section about installation, configuration, and operation of this equipment before you install, configure, operate, or maintain this product. Users are required to familiarize themselves with installation and wiring instructions in addition to requirements of all applicable codes, laws, and standards.

Installation, adjustments, putting into service, use, assembly, disassembly, and maintenance are required to be carried out by suitably trained personnel in accordance with applicable code of practice. In case of malfunction or damage, no attempts at repair should be made. The module should be returned to the manufacturer for repair. Do not dismantle the module.

North American Hazardous Location Approval

| The Following Information Applies When Operating This Equipment In Hazardous Locations. | Informations sur l'utilisation de cet équipement en environnements dangereux. |
|---|---|
| <p>Products marked "CL I, DIV 2, GP A, B, C, D" are suitable for use in Class I Division 2 Groups A, B, C, D, Hazardous Locations and nonhazardous locations only. Each product is supplied with markings on the rating nameplate indicating the hazardous location temperature code. When combining products within a system, the most adverse temperature code (lowest "T" number) may be used to help determine the overall temperature code of the system. Combinations of equipment in your system are subject to investigation by the local Authority Having Jurisdiction at the time of installation.</p> | <p>Les produits marqués "CL I, DIV 2, GP A, B, C, D" ne conviennent qu'à une utilisation en environnements de Classe I Division 2 Groupes A, B, C, D dangereux et non dangereux. Chaque produit est livré avec des marquages sur sa plaque d'identification qui indiquent le code de température pour les environnements dangereux. Lorsque plusieurs produits sont combinés dans un système, le code de température le plus défavorable (code de température le plus faible) peut être utilisé pour déterminer le code de température global du système. Les combinaisons d'équipements dans le système sont sujettes à inspection par les autorités locales qualifiées au moment de l'installation.</p> |
| <div style="display: flex; align-items: center;">  <div> <p>WARNING: Explosion Hazard -</p> <ul style="list-style-type: none"> • Do not disconnect equipment unless power has been removed or the area is known to be nonhazardous. • Do not disconnect connections to this equipment unless power has been removed or the area is known to be nonhazardous. Secure any external connections that mate to this equipment by using screws, sliding latches, threaded connectors, or other means provided with this product. • Substitution of components may impair suitability for Class I, Division 2. </div> </div> | <div style="display: flex; align-items: center;">  <div> <p>AVERTISSEMENT: Risque d'Explosion -</p> <ul style="list-style-type: none"> • Couper le courant ou s'assurer que l'environnement est classé non dangereux avant de débrancher l'équipement. • Couper le courant ou s'assurer que l'environnement est classé non dangereux avant de débrancher les connecteurs. Fixer tous les connecteurs externes reliés à cet équipement à l'aide de vis, loquets coulissants, connecteurs filetés ou autres moyens fournis avec ce produit. • La substitution de composants peut rendre cet équipement inadapté à une utilisation en environnement de Classe I, Division 2. </div> </div> |

UK and European Hazardous Location Approval

The following applies to products marked **CE**  **II 3G:**

- Are intended for use in potentially explosive atmospheres as defined by European Union Directive 2014/34/EU and has been found to comply with the Essential Health and Safety Requirements relating to the design and construction of Category 3 equipment intended for use in Zone 2 potentially explosive atmospheres, given in Annex II to this Directive.
- Compliance with the Essential Health and Safety Requirements has been assured by compliance with EN IEC 60079-0:2018 and EN IEC 60079-7:2015/A1:2018.
- Are Equipment Group II, Equipment Category 3, and comply with the Essential Health and Safety Requirements relating to the design and construction of such equipment given in Annex II to EU Directive 2014/34/EU. See the EU Declaration of Conformity rok.auto/certifications for details.
- The type of protection is Ex ec IIC T4 Gc according to EN IEC 60079-0:2018, EXPLOSIVE ATMOSPHERES - PART 0: EQUIPMENT - GENERAL REQUIREMENTS, Issue Date 07/2018 and EN IEC 60079-7:2015+A1:2018, Explosive atmospheres. Equipment protection by increased safety "e".
- Comply to Standard EN IEC 60079-0:2018, EXPLOSIVE ATMOSPHERES - PART 0: EQUIPMENT - GENERAL REQUIREMENTS, Issue Date 07/2018, EN IEC 60079-7:2015+A1:2018 Explosive atmospheres. Equipment protection by increased safety "e", reference certificate number DEMKO 04 ATEX 0330347X and UL220KEX2478X.
- Are intended for use in areas in which explosive atmospheres caused by gases, vapors, mists, or air are unlikely to occur, or are likely to occur only infrequently and for short periods. Such locations correspond to Zone 2 classification according to UKEX regulation 2016 No. 1107 and ATEX directive 2014/34/EU.
- May have catalog numbers followed by a "K" to indicate a conformal coating option.

IEC Hazardous Location Approval

The following applies to products marked with IECEx certification:

- Are intended for use in areas in which explosive atmospheres caused by gases, vapors, mists, or air are unlikely to occur, or are likely to occur only infrequently and for short periods. Such locations correspond to Zone 2 classification to IEC 60079-0.
- The type of protection is Ex ec IIC T4 Gc according to IEC 60079-0 and IEC 60079-7.
- Comply with Standards IEC 60079-0, Explosive atmospheres – Part 0: Equipment – General requirements, Edition 7, Revision Date 2017 and IEC 60079-7, 5.1 Edition revision date 2017, Explosive atmospheres – Part 7: Equipment protection by increased safety “e”, reference IECEx certificate number IECEx UL 20.0072X.
- May have catalog numbers followed by a “K” to indicate a conformal coating option.

Special Conditions for Safe Use



WARNING:

- This equipment is not resistant to sunlight or other sources of UV radiation.
- This equipment shall be mounted in an UKEX/ATEX/IECEx Zone 2 certified enclosure with a minimum ingress protection rating of at least IP54 (in accordance with EN/IEC 60079-0) and used in an environment of not more than Pollution Degree 2 (as defined in EN/IEC 60664-1) when applied in Zone 2 environments. The enclosure must be accessible only by the use of a tool.
- This equipment shall be used within its specified ratings defined by Rockwell Automation®.
- Transient protection shall be provided that is set at a level not exceeding 140% of the peak rated voltage value at the supply terminals to the equipment.
- Earthing is accomplished through mounting of modules on rail.
- The instructions in the user manual shall be observed.
- This equipment must be used only with UKEX/ATEX/IECEx certified Rockwell Automation backplanes.
- Secure any external connections that mate to this equipment by using screws, sliding latches, threaded connectors, or other means provided with this product.
- Do not disconnect equipment unless power has been removed or the area is known to be nonhazardous. Earthing is accomplished through mounting of modules on rail.
- Devices shall be used in an environment of not more than Pollution Degree 2.

Prevent Electrostatic Discharge



ATTENTION: This equipment is sensitive to electrostatic discharge, which can cause internal damage and affect normal operation. Follow these guidelines when you handle this equipment:

- Touch a grounded object to discharge potential static.
- Wear an approved grounding wriststrap.
- Do not touch connectors or pins on component boards.
- Do not touch circuit components inside the equipment.
- Use a static-safe workstation, if available.
- Store the equipment in appropriate static-safe packaging when not in use.

About the Module

The POINT I/O™ 4 channel IO-Link master module provides four channels that can be individually configured as IO-Link master or as a standard digital I/O module. The IO-Link channel master module can be configured to fit any IO-Link and/or discrete application.

In IO-Link mode, the module supports four channels for IO-Link master communication with IO-Link compatible devices. In standard digital I/O mode, the module supports four channels of digital input or output. Standard digital input channels support IEC61131-2 type 1 input. Channels can also be disabled if not in use.

You must use this module with the following:

- 1734-AENT or 1734-AENTR, Series B EtherNet/IP™ adapters with firmware revision 5.012 or later
- 1734-AENT or 1734-AENTR, Series C EtherNet/IP adapters with firmware revision 6.011 or later
- Studio 5000 Logix Designer® application, version 20 or later

Use the following diagrams and tables to identify the external features of the module.

POINT I/O 4 Channel IO-Link Master Module with 1734-TB, 1734-TBS, 1734-TB3, or 1734-TB3S Wiring Base Assembly

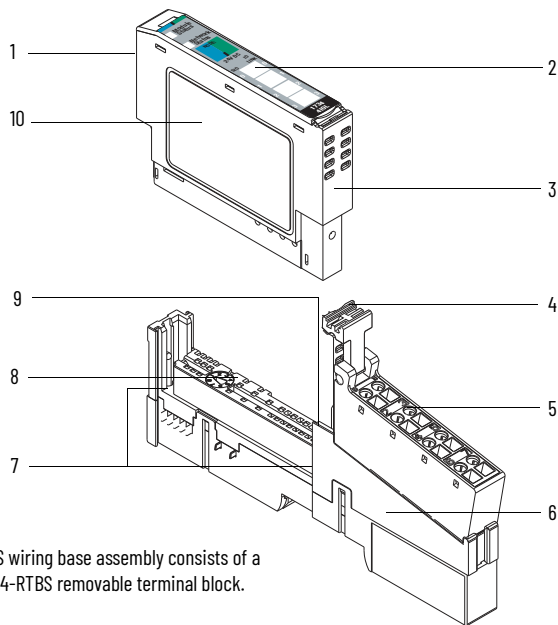

The 1734-TB, 1734-TBS, 1734-TB3, or 1734-TB3S wiring base assembly consists of a 1734-MB mounting base and a 1734-RTB or 1734-RTBS removable terminal block.

| | Description | | Description |
|---|---------------------------------------|----|---------------------------------|
| 1 | Module locking mechanism | 6 | Terminal base |
| 2 | Slide-in writable label | 7 | Interlocking side pieces |
| 3 | Insertable I/O module | 8 | Mechanical keying (orange) |
| 4 | Removable terminal block (RTB) handle | 9 | DIN rail locking screw (orange) |
| 5 | Removable terminal block | 10 | Module wiring diagram |

POINT I/O 4 Channel IO-Link Master Module with 1734-TOP, 1734-TOPS, 1734-TOP3, or 1734-TOP3S One-piece Terminal Base

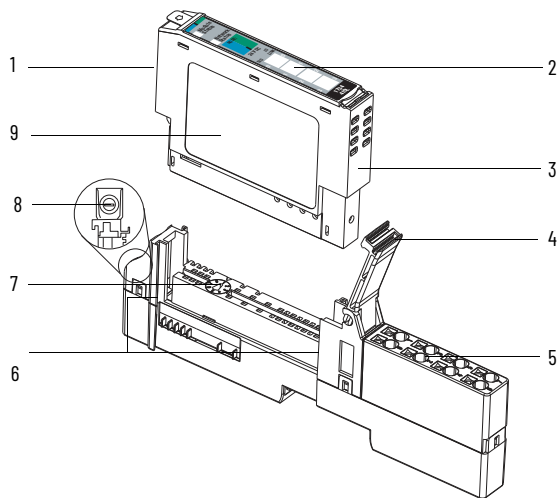

| | Description | | Description |
|---|--------------------------|---|---------------------------------|
| 1 | Module locking mechanism | 6 | Interlocking side pieces |
| 2 | Slide-in writable label | 7 | Mechanical keying (orange) |
| 3 | Insertable I/O module | 8 | DIN rail locking screw (orange) |
| 4 | Terminal block handle | 9 | Module wiring diagram |
| 5 | One-piece terminal base | | |

Install the Mounting Base

To install the mounting base on the DIN rail, proceed as follows:

1. Position the mounting base vertically above the installed units (adapter, power supply, or existing module).

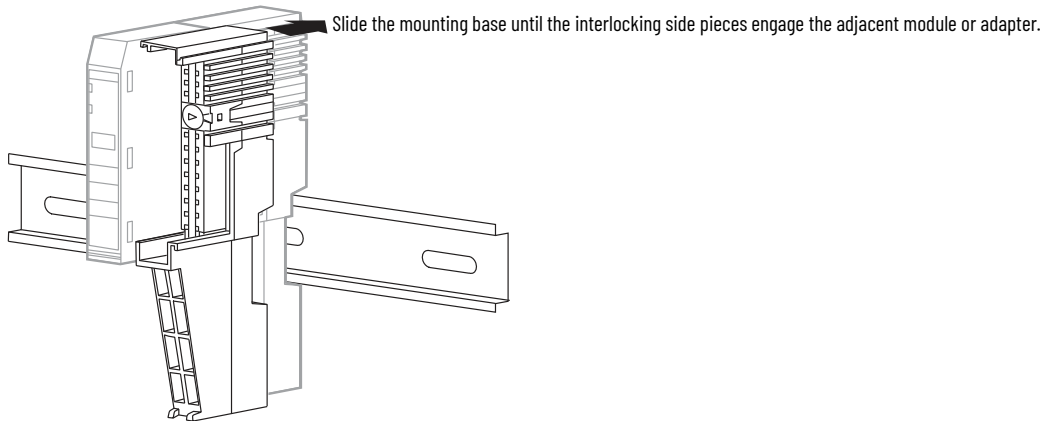

2. Slide the mounting base down allowing the interlocking side pieces to engage the adjacent module or adapter.
3. Press firmly to seat the mounting base on the DIN rail. The mounting base snaps into place. Be sure that the orange DIN rail locking screw is in the horizontal position and that it has engaged the DIN rail.

Install the Module

The module can be installed before or after base installation. Make sure that the mounting base is correctly keyed before installing the module into the mounting base. In addition, make sure that the mounting base locking screw is positioned horizontal referenced to the base.

1734-TB Base

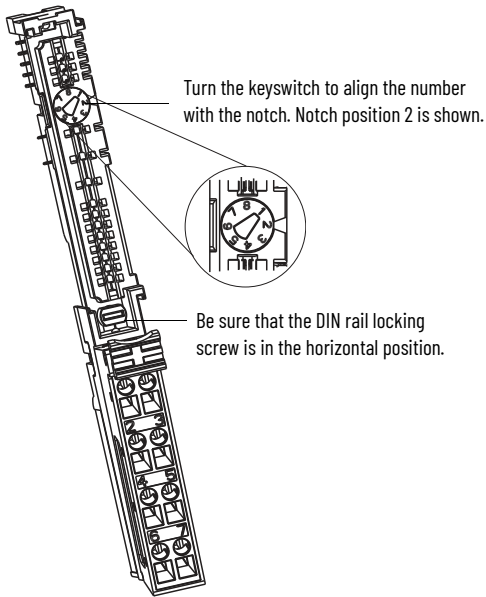

1734-TOP Base

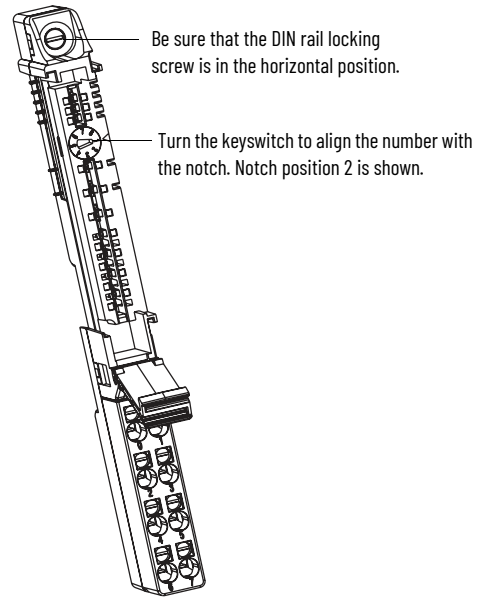

1. Use a bladed screwdriver and rotate the keyswitch on the mounting base clockwise until the number required for the type of module being installed aligns with the notch in the base.
2. Verify that the DIN rail locking screw is in the horizontal position. You cannot insert the module if the locking mechanism is unlocked.
3. Insert the module straight down into the mounting base.

4. Press to secure. The module locks into place.

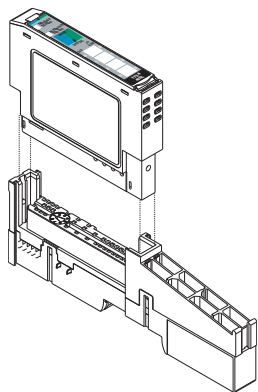

Install the Removable Terminal Block

A Removable Terminal Block (RTB) is supplied with your wiring base assembly. To remove, pull up on the RTB handle. This allows the mounting base to be removed and replaced as necessary without removing any of the wirings. To reinsert the Removable Terminal Block, proceed as follows:



WARNING: When you connect or disconnect the Removable Terminal Block (RTB) with field-side power applied, an electrical arc can occur. This can cause an explosion in hazardous location installations. Be sure that power is removed or the area is nonhazardous before proceeding.

1. Insert the end opposite the handle into the base unit. This end has a curved section that engages with the wiring base.
2. Rotate the terminal block into the wiring base until it locks itself in place.
3. If an I/O module is installed, snap the RTB handle into place on the module.

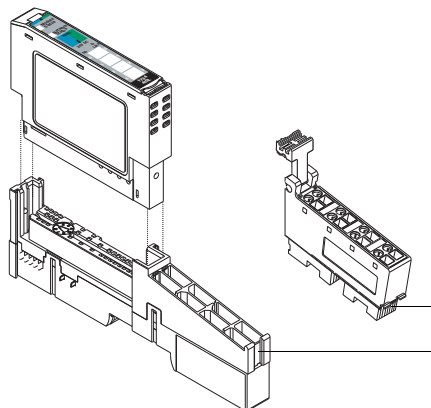

Hook the RTB end into the mounting base end and rotate until it locks into place.



WARNING: For 1734-RTBS and 1734-RTB3S, to latch and unlatch the wire, insert a bladed screwdriver (catalog number 1492-N90 - 3 mm diameter blade) into the opening at approximately 73° (blade surface is parallel with top surface of the opening) and push up gently.

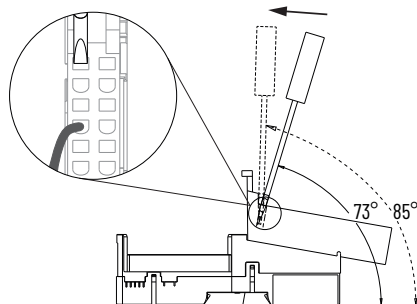



WARNING: For 1734-TOPS and 1734-TOP3S, to latch and unlatch the wire, insert a bladed screwdriver (catalog number 1492-N90 – 3 mm diameter) into the opening at approximately 97° (blade surface is parallel with top surface of the opening) and press in (do not push up or down).

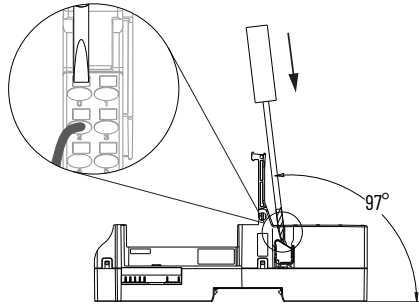

Remove a Mounting Base

To remove a mounting base, you must remove any installed module, and the module installed in the base to the right. Remove the RTB, if wired.

1. Unlatch the RTB handle on the I/O module.
2. Pull on the RTB handle to remove the RTB.
3. Press the module lock on the top of the module.
4. Pull on the I/O module to remove from the base.
5. Repeat steps 1, 2, 3, and 4 for the module to the right.
6. Use a small bladed screwdriver to rotate the orange base locking screw to a vertical position. The locking mechanism releases.
7. Lift straight up to remove.

Wire the Module

To wire the module, see the following diagrams and tables.

POINT I/O 4 Channel IO-Link Master Module – 1734-4IOL

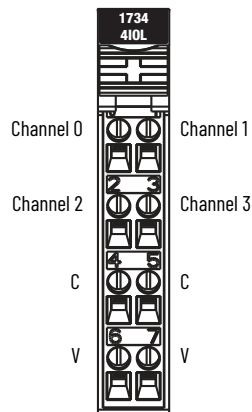

POINT I/O 4 Channel IO-Link Master Module Wiring – IO-Link Mode

CH = IO-Link channel
 C = Common
 V = 24V DC
 Device = IO-Link device (actuators, sensors)

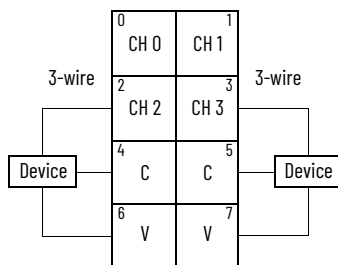

V power is not protected and is limited to 0.3 A max per module.

| Channel | Common | Voltage |
|-----------|--------|---------|
| Channel 0 | 4 | 6 |
| Channel 1 | 5 | 7 |
| Channel 2 | 4 | 6 |
| Channel 3 | 5 | 7 |

Power is supplied through the internal 24V DC power bus.

POINT I/O 4 Channel IO-Link Master Module Wiring – Standard Digital Input Mode

In = Input channel
 C = Common
 V = 24V DC

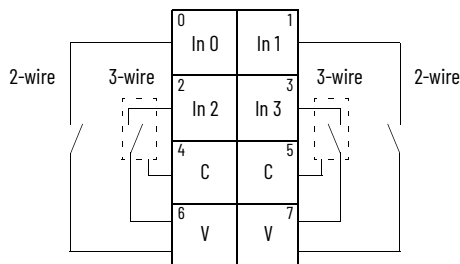

V power is not protected and is limited to 0.3 A max per module.

| Channel | Input | Common | Voltage |
|-----------|-------|--------|---------|
| Channel 0 | 0 | 4 | 6 |
| Channel 1 | 1 | 5 | 7 |
| Channel 2 | 2 | 4 | 6 |
| Channel 3 | 3 | 5 | 7 |

Connect common on 3-wire inputs. Power is supplied through the internal 24V DC power bus.

POINT I/O 4 Channel IO-Link Master Module Wiring – Standard Digital Output Mode

Out = Output channel
 C = Common
 V = 24V DC

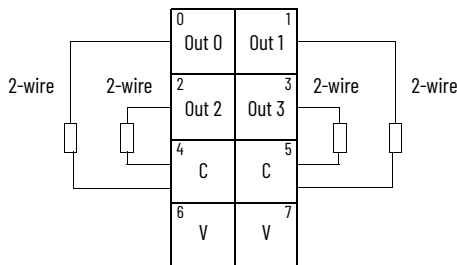

V power is not protected and is limited to 0.3 A max per module.

| Channel | Output | Common | Voltage |
|-----------|--------|--------|---------|
| Channel 0 | 0 | 4 | 6 |
| Channel 1 | 1 | 5 | 7 |
| Channel 2 | 2 | 4 | 6 |
| Channel 3 | 3 | 5 | 7 |

Power is supplied through the internal 24V DC power bus.

Communicate with Your Module

POINT I/O modules send (produce) and receive (consume) I/O data (messages). You map this data into the memory of the processor.

The consumed and produced connection sizes may range from 0...32 bytes.

Default Data Map for 1734-4IOL – Configuration Assembly Instance 100

Message size: 46 Bytes

| Consumed Byte | Bit 7 | Bit 6 | Bit 5 | Bit 4 | Bit 3 | Bit 2 | Bit 1 | Bit 0 |
|---------------|---|-------|-------|-------|-------|-------|-------|-------|
| 36 | Channel 0 fault mode ⁽¹⁾ | | | | | | | |
| 37 | Channel 0 idle mode ⁽¹⁾ | | | | | | | |
| 38 | Channel 1 fault mode ⁽¹⁾ | | | | | | | |
| 39 | Channel 1 idle mode ⁽¹⁾ | | | | | | | |
| 40 | Channel 2 fault mode ⁽¹⁾ | | | | | | | |
| 41 | Channel 2 idle mode ⁽¹⁾ | | | | | | | |
| 42 | Channel 3 fault mode ⁽¹⁾ | | | | | | | |
| 43 | Channel 3 idle mode ⁽¹⁾ | | | | | | | |
| 44 | Channel 0 input off to on time delay ⁽²⁾ | | | | | | | |
| 45 | Channel 0 input on to off time delay ⁽²⁾ | | | | | | | |
| 46 | Channel 1 input off to on time delay ⁽²⁾ | | | | | | | |
| 47 | Channel 1 input on to off time delay ⁽²⁾ | | | | | | | |
| 48 | Channel 2 input off to on time delay ⁽²⁾ | | | | | | | |
| 49 | Channel 2 input on to off time delay ⁽²⁾ | | | | | | | |
| 50 | Channel 3 input off to on time delay ⁽²⁾ | | | | | | | |
| 51 | Channel 3 input on to off time delay ⁽²⁾ | | | | | | | |

(1) Fault and idle conditions are only valid when the channel is configured for IO-Link or DO. Mode and Value behavior is defined in the IO-Link Channel object specification.

(2) Time delays are specified in 1 ms increments, the valid range is 0...65 (a value of zero disables the input filter).

Default Data Map for 1734-4IOL – Consumed Assembly Instance 101

Message size: 0...128 Bytes

| Consumed Byte | Bit 7 | Bit 6 | Bit 5 | Bit 4 | Bit 3 | Bit 2 | Bit 1 | Bit 0 |
|---------------|--|-------|-------|-------|-------|-------|-------|-------|
| 0...a | Output data for Channel 0 ⁽¹⁾ | | | | | | | |
| a+1...b | Output data for Channel 1 ⁽¹⁾ | | | | | | | |
| b+1...c | Output data for Channel 2 ⁽¹⁾ | | | | | | | |
| c+1...d | Output data for Channel 3 ⁽¹⁾ | | | | | | | |

(1) Consumed sizes can be in the range of 0...32. Output data for each channel always begin on a 32-bit boundary, and is enforced by software using the data description for the channel.

Default Data Map for 1734-4IOL – Produced Assembly Instance 102

Message size: 0...132 Bytes

| Consumed Byte | Bit 7 | Bit 6 | Bit 5 | Bit 4 | Bit 3 | Bit 2 | Bit 1 | Bit 0 |
|---------------|--|-------|-------|-------|-------|-------|-------|-------|
| 0 | Channel 0 status ⁽¹⁾ | | | | | | | |
| 2 | Channel 1 status ⁽¹⁾ | | | | | | | |
| 4 | Channel 2 status ⁽¹⁾ | | | | | | | |
| 6 | Channel 3 status ⁽¹⁾ | | | | | | | |
| 8 | Channel 0 most recent event | | | | | | | |
| 12 | Channel 1 most recent event | | | | | | | |
| 16 | Channel 2 most recent event | | | | | | | |
| 20 | Channel 3 most recent event | | | | | | | |
| 24...a | Input data from Channel 0 ⁽²⁾ | | | | | | | |

Default Data Map for 1734-4IOL – Produced Assembly Instance 102 (Continued)

Message size: 0...132 Bytes

| Consumed Byte | Bit 7 | Bit 6 | Bit 5 | Bit 4 | Bit 3 | Bit 2 | Bit 1 | Bit 0 |
|---------------|--|-------|-------|-------|-------|-------|-------|-------|
| a+1...b | Input data from Channel 1 ⁽²⁾ | | | | | | | |
| b+1...c | Input data from Channel 2 ⁽²⁾ | | | | | | | |
| c+1...d | Input data from Channel 3 ⁽²⁾ | | | | | | | |

- (1) Channel status:
 - Bit 0: 0 = Roll-up status, an OR of bits 1...7
 - Bit 1: 0 = Connection to device, 1 = No connection to device
 - Bit 2: 1 = Configuration to device in progress
 - Bit 3: 1 = Device configuration failed
 - Bit 4: 1 = IO-Link key failure
 - Bit 5: 1 = DO short circuit
 - Bit 6: 1 = Process data invalid
 - Bit 7: 1 = Low-power fault
 - Bit 8: 1 = IO-Link output value is forced to limit
 - Bit 9...15: Reserved
- (2) Produced sizes can be in the range of 0...32. Input data for each channel always begin on a 32-bit boundary, and is enforced by software using the data description for the channel.

Interpret Status Indicators

See the following diagram and table for information on how to interpret the status indicators.

POINT I/O 4 Channel IO-Link Master Module – 1734-4IOL

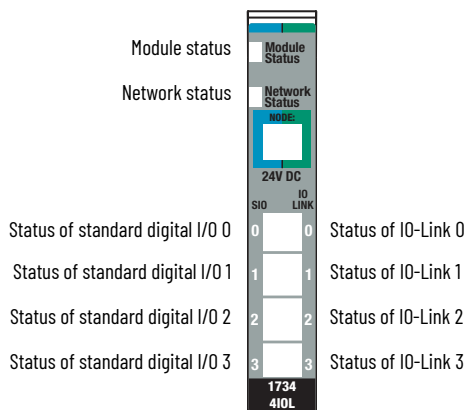

Indicator Status for Modules

| | Status | Description |
|--------------------------------------|--------------------|---|
| Module status | Off | No power is applied to device. |
| | Green | Device is operating normally. |
| | Flashing green | Device needs commissioning due to missing, incomplete, or incorrect configuration. |
| | Flashing red | A recoverable fault occurred. |
| | Red | An unrecoverable fault occurred – may require device replacement. |
| Network status | Flashing red/green | Device is in self-test mode. |
| | Off | Device is not online: <ul style="list-style-type: none"> - Device has not completed dup-MAC-id test. - Device is not powered – check module status indicator. - No network power is present. |
| | Flashing green | Device is online but has no connections in the established state. |
| | Green | Device is online and has connections in the established state. |
| | Flashing red | One or more I/O connections are in timed-out state. |
| Standard digital input/output status | Red | Critical link failure – failed communication device. Device detected error that prevents it from communicating on the network. |
| | Flashing red/green | Communication faulted device – the device has detected a network access error and is in communication faulted state. Device has received and accepted an Identity Communication Faulted Request – long protocol message. |
| IO-Link status | Off | Standard digital input/output is offline, configured in IO-Link mode, or no power is applied to device. |
| | Yellow | Standard digital input/output is in ON state. |
| | Off | IO-Link is disabled, channel configured as standard digital I/O, or no power is applied to device. |
| IO-Link status | Flashing green | Port starting up or no IO-Link device is detected. |
| | Green | IO-Link is operating normally. |

Specifications

General Specifications

| Attribute | Value |
|-----------------------------------|--|
| Number of inputs | 4 single-ended, non-mutual isolated, configurable |
| Number of outputs | |
| Communication rate, IO-Link | 4.8 kB; 38.4 kB; 230.4 kB |
| Device cable length, IO-Link, max | 20 m (65.6 ft) |
| Terminal base screw torque | 0.8 N•m (7 lb•in) |
| Module location | 1734-TB, 1734-TBS, 1734-TB3, 1734-TB3S, 1734-TOP, 1734-TOPS, 1734-TOP3, or 1734-TOP3S wiring base assembly |
| POINTBus™ current, max | 100 mA @ 5V DC |
| Power dissipation, max | 1.5 W @ 28.8V DC |
| Thermal dissipation, max | 5.12 BTU/hr @ 28.8V DC |
| Isolation voltage | 50V (continuous), basic insulation type Tested at 2121V DC for 60 s, field-side to system. No isolation between individual channels. |
| Field power bus supply, nom | 24V DC |
| Field power bus supply, min | 19.2V DC |
| Field power bus supply, max | 28.8V DC |
| Backplane power | 5V DC, 100 mA |
| Input ratings | 24V DC, 12 mA |
| Output ratings, per channel | 24V DC, 0.15 A |
| Output ratings, per module, max | 24V DC, 0.6 A |
| Indicators | 1 green/red - Module status indicator 1 green/red - Network status indicator 4 yellow - Channel status indicators 4 green - IO-Link status indicators |
| Wiring category ⁽¹⁾ | 2 - on signal ports |
| Wire size | 0.25...2.5 mm ² (22...14 AWG) solid or stranded copper wire that is rated at 75 °C (167 °F), or greater. 1.2 mm (3/64 in.) insulation max |
| Wire type | Copper |
| Dimensions, approx., HxWxD | 56 x 12 x 75.5 mm (2.21 x 0.47 x 2.97 in.) |
| Weight, approx. | 36 g (1.27 oz) |
| Enclosure type rating | None (open-style) |
| UKEX/ATEX/IECEx temp code | T4 |
| Keyswitch position | 2 |

(1) Use this Conductor Category information for planning conductor routing as described in the appropriate System Level Installation Manual. See Industrial Automation Wiring and Grounding Guidelines, publication [1770-4.1](#), for more information.

POINT I/O 4 Channel IO-Link Master Module 1734-4IOL, 1734-4IOLK - Standard Digital Input

| Attribute | Value |
|--|---|
| Backplane power | 5V DC, 100 mA |
| Input ratings | 24V DC, 12 mA |
| On-state voltage, min | 13V DC |
| On-state voltage, max | 30V DC |
| On-state current, min | 5.0 mA |
| On-state current, nom | 5.8 mA |
| On-state current, max | 6.6 mA |
| Off-state voltage, max | 5V DC |
| Off-state current, max | 6.6 mA |
| Input filter ON to OFF OFF to ON | Each input independently settable in 1 ms intervals. Default value is 1 ms. 0...65 ms 0...65 ms |

POINT I/O 4 Channel IO-Link Master Module 1734-4IOL, 1734-4IOLK - Standard Digital Output

| Attribute | Value |
|---------------------------------|----------------|
| Backplane power | 5V DC, 100 mA |
| Output ratings, per channel | 24V DC, 0.15 A |
| Output ratings, per module, max | 24V DC, 0.6 A |
| On-state voltage, min | 19.2V DC |

POINT I/O 4 Channel IO-Link Master Module 1734-4IOL, 1734-4IOLK – Standard Digital Output (Continued)

| Attribute | Value |
|-----------------------------------|--|
| On-state voltage, max | 28.8V DC |
| On-state voltage, nom | 24V DC |
| On-state voltage drop, max | 0.9V DC |
| On-state current, max | 150 mA |
| Off-state current leakage, max | 0.5 mA |
| Module current (all outputs), max | 600 mA |
| Surge current, max | 0.25 A for 10 ms, repeatable every 3 s |

Environmental Specifications

| Attribute | Value |
|-----------------------------------|--|
| Temperature, operating | IEC 60068-2-1 (Test Ad, operating cold), IEC 60068-2-2 (Test Bd, operating dry heat), IEC 60068-2-14 (Test Nb, operating thermal shock): -20...+55 °C (-4...+131 °F) |
| Temperature, nonoperating | IEC 60068-2-1 (Test Ab, Unpackaged no-operating cold), IEC 60068-2-2 (Test Bb, Unpackaged nonoperating dry heat), IEC 60068-2-14 (Test Na, Unpackaged nonoperating thermal shock): -40...+85 °C (-40...+185 °F) |
| Temperature, surrounding air, max | 55 °C (131 °F) |
| Relative humidity | IEC 60068-2-30 (Test Db, Unpackaged Nonoperating Damp Heat): 5...95% noncondensing |
| Vibration | IEC 60068-2-6 (Test Fc, operating) 5 g @ 10...500 Hz |
| Shock, operating | IEC 60068-2-27 (Test Ea, unpackaged shock): 30 g |
| Shock, nonoperating | IEC 60068-2-27 (Test Ea, unpackaged shock): 50 g |
| Emissions | IEC 61000-6-4 |
| ESD immunity | IEC 61000-4-2: 6 kV contact discharges 8 kV air discharges |
| Radiated RF immunity | IEC 61000-4-3: 10V/m with 1 kHz sine-wave 80% AM from 80...6000 MHz |
| EFT/B immunity | IEC 61000-4-4: ±2 kV at 5 kHz on power ports ±2 kV at 5 kHz on signal ports |
| Surge transient immunity | IEC 61000-4-5: ±1 kV line-line (DM) and ±2 kV line-earth (CM) on signal ports |
| Conducted RF immunity | IEC 61000-4-6: 10V rms with 1 kHz sine-wave 80% AM from 150 kHz...80 MHz |

Certifications

| Certification (When Product Is Marked) ⁽¹⁾ | Value |
|---|---|
| c-UL-us | UL Listed Industrial Control Equipment, certified for US and Canada. See UL File E322657. |
| UKCA and CE | UK Statutory Instrument 2016 No. 1091 and European Union 2014/30/EU EMC Directive, compliant with: EN 61326-1; Measurement/Control/Laboratory use, Industrial requirements EN 61000-6-2; Industrial Immunity EN 61000-6-4; Industrial Emissions EN 61131-2; Programmable Controllers (Clause 8, Zone A & B) UK Statutory Instrument 2012 No. 3032 and European Union 2011/65/EU RoHS, compliant with: EN 63000; Technical documentation |
| Ex  | UK Statutory Instrument 2016 No. 1107 and European Union 2014/34/EU ATEX Directive, compliant with: EN IEC 60079-0; General Requirements EN IEC 60079-7; Explosive Atmospheres, Protection "e" II 3 G Ex ec IIC T4 Gc DEMKO 04 ATEX 0330347X and UL22UKEX2478X |
| IECEX | IECEX System, compliant with: IEC 60079-0; General Requirements IEC 60079-7; Explosive Atmospheres, Protection "e" II 3G Ex ec IIC T4 Gc IECEX UL 20.0072X |

Certifications (Continued)

| Certification (When Product Is Marked) ⁽¹⁾ | Value |
|--|---|
| KC | Korean Registration of Broadcasting and Communications Equipment, compliant with: Article 58-2 of Radio Waves Act, Clause 3 |
| RCM | Australian Radiocommunications Act, compliant with: AS/NZS CISPR 11:201 (Group 1, Class A) |
| CCC  | CNCA-C23-01:2019 CCC Implementation Rule Explosion-Proof Electrical Products, compliant with: GB/T 3836.1-2021 Explosive atmospheres—Part 1:Equipment—General requirements GB/T 3836.3-2021 Explosive atmospheres—Part 3:Equipment protection by increased safety “e” GB/T 3836.8-2021 Electrical apparatus for explosive gas atmospheres -- Part 8:Type of protection “n” CCC 202012230911607 (APBC) |

(1) See the Product Certification link at rok.auto/certifications for Declaration of Conformity, Certificates, and other certification details.

Notes:

Rockwell Automation Support

Use these resources to access support information.

| | | |
|---|---|--|
| Technical Support Center | Find help with how-to videos, FAQs, chat, user forums, Knowledgebase, and product notification updates. | rok.auto/support |
| Local Technical Support Phone Numbers | Locate the telephone number for your country. | rok.auto/phonesupport |
| Technical Documentation Center | Quickly access and download technical specifications, installation instructions, and user manuals. | rok.auto/techdocs |
| Literature Library | Find installation instructions, manuals, brochures, and technical data publications. | rok.auto/literature |
| Product Compatibility and Download Center (PCDC) | Download firmware, associated files (such as AOP, EDS, and DTM), and access product release notes. | rok.auto/pcdc |

Documentation Feedback

Your comments help us serve your documentation needs better. If you have any suggestions on how to improve our content, complete the form at rok.auto/docfeedback.





Waste Electrical and Electronic Equipment (WEEE)



At the end of life, this equipment should be collected separately from any unsorted municipal waste.

Rockwell Automation maintains current product environmental compliance information on its website at rok.auto/pec.

Rockwell Otomasyon Ticaret A.Ş. Kar Plaza İş Merkezi E Blok Kat:6 34752 İçerenköy, İstanbul, Tel: +90 (216) 5698400 EEE Yönetmeliğine Uygundur

Connect with us.    

rockwellautomation.com — expanding **human possibility**[®]

AMERICAS: Rockwell Automation, 1201 South Second Street, Milwaukee, WI 53204-2496 USA, Tel: (1) 414.382.2000

EUROPE/MIDDLE EAST/AFRICA: Rockwell Automation NV, Pegasus Park, De Kleetlaan 12a, 1831 Diegem, Belgium, Tel: (32) 2663 0600

ASIA PACIFIC: Rockwell Automation SEA Pte Ltd, 2 Corporation Road, #04-05, Main Lobby, Corporation Place, Singapore 618494, Tel: (65) 6510 6608

UNITED KINGDOM: Rockwell Automation Ltd., Pitfield, Kiln Farm, Milton Keynes, MK11 3DR, United Kingdom, Tel: (44)(1908) 838-800

Allen-Bradley, expanding human possibility, FactoryTalk, POINTBus, POINT I/O, Rockwell Automation, Studio 5000 Logix Designer, and TechConnect are trademarks of Rockwell Automation, Inc.

EtherNet/IP is a trademark of ODVA, Inc.

Trademarks not belonging to Rockwell Automation are property of their respective companies.

Publication 1734-IN043D-EN-E - February 2024 | Supersedes Publication 1734-IN043C-EN-E - March 2021

Copyright © 2024 Rockwell Automation, Inc. All rights reserved.