

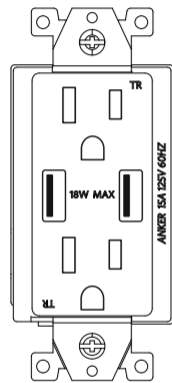

Charge Fast, Live More



## PowerExtend USB Wall Outlet 2-Outlet USER MANUAL

### WARNINGS

**⚠️** TO AVOID FIRE, SHOCK, OR DEATH, TURN OFF POWER AT CIRCUIT BREAKER AND MAKE SURE THE POWER IS TURNED OFF BEFORE WIRING.

#### Important Safety Instructions

- Intended for indoor use only.
- Use this device with copper or copper clad wire only.
- Do not exceed electrical ratings.
- Use in dry locations and indoors only.
- Install PowerExtend away from heat-emitting appliances such as radiators.
- Keep children away from PowerExtend.

#### ADVERTENCIAS:

**⚠️** PARA EVITAR INCENDIOS, DESCARGAS ELÉCTRICAS O LA MUERTE, APAGUE LA CORRIENTE EN EL DISYUNTOR Y ASEGURESE DE QUE LA CORRIENTE ESTE APAGADA ANTES DE CONECTAR EL CABLEADO.

#### Instrucciones de seguridad importantes

- Previsto únicamente para uso en interiores.
- Utilice este dispositivo solo con cables de cobre o con revestimiento de cobre.
- No supere la clasificación eléctrica.
- Utilice este producto solo en ubicaciones secas en interiores.
- Instale la toma de pared PowerExtend alejada de dispositivos emisores de calor, como radiadores.
- Mantenga a los niños alejados de la toma de pared PowerExtend. Keep children away from PowerExtend.

### At a Glance

ES: Vista general

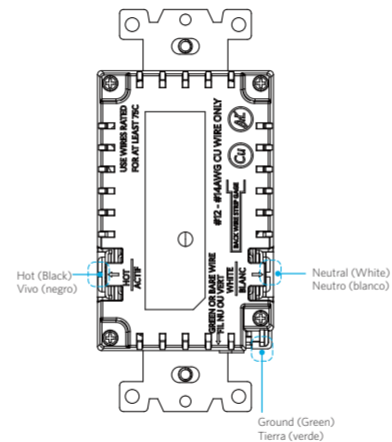
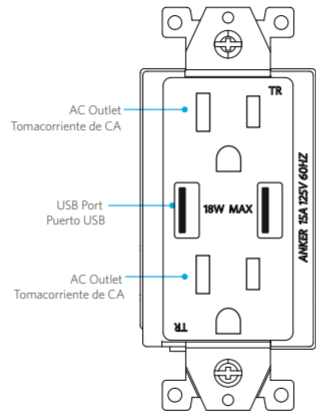

### Installing PowerExtend USB Wall Outlet 2-Outlet

#### Instalación de la toma de pared USB PowerExtend con 2 tomas

Note: Make sure you shut off power before installing the wall outlet.

ES: Nota: Asegúrese de apagar la corriente antes de instalar la toma de pared.

1. This device is to be installed in a standard single gang electrical wall box (3" x 2" x 2½").

ES: Este dispositivo se debe instalar en un cajetín eléctrico de pared estándar de entrada única (3" x 2" x 2½").

2. Strip away the insulation until you have enough cable to wrap around the screw.

ES: Pele el revestimiento aislante hasta que quede expuesto suficiente cable para envolver el tornillo.

3. Loosen the screw and connect wires correspondingly as illustrated:

Connect the green (Ground) wire to the green lead. Connect the black (Hot) wire to the screw marked "HOT".

Connect the white (Neutral) wire to the screw marked "WHITE".

ES: Afloje el tornillo y conecte los cables como se indica a continuación:

Conecte el cable verde (tierra) al terminal verde.

Conecte el cable negro (vivo) al tornillo marcado como "HOT".

Conecte el cable neutro (blanco) al tornillo marcado como "WHITE".

4. Wrap the wire around the screws tightly and then firmly secure the wires using the screws.

Tightening Torque: min. 0.8 Nm

ES: Enrolle el cable alrededor de los tornillos firmemente y luego fije los cables con firmeza usando los tornillos.

Par de apriete: 0,8 Nm mín.

5. Mount the wall outlet into a wall box using the provided screws and mount wall plate.

ES: Instale la toma de pared en un cajetín de pared mediante el uso de los tornillos y la placa de montaje en pared suministrados.

6. Restore power at the circuit breaker.

ES: Reanude la corriente en el disyuntor.

### Specifications

ES: Especificaciones

Electrical Rating Clasificación eléctrica	125V~60Hz 15A 1875W
USB Output Salida USB	5V $\equiv$ 2.4A
Size Tamaño	70 x 50 x 45 mm / 2.7 x 2.0 x 1.8 in

For FAQs and more information, please visit:  
**anker.com/support**



@anker\_official  
@anker\_jp



@Anker Deutschland  
@Anker Japan  
@Anker



@AnkerOfficial  
@Anker\_JP

## Using PowerExtend USB Wall Outlet 2- Outlet

Uso de la toma de pared USB PowerExtend con 2 tomas

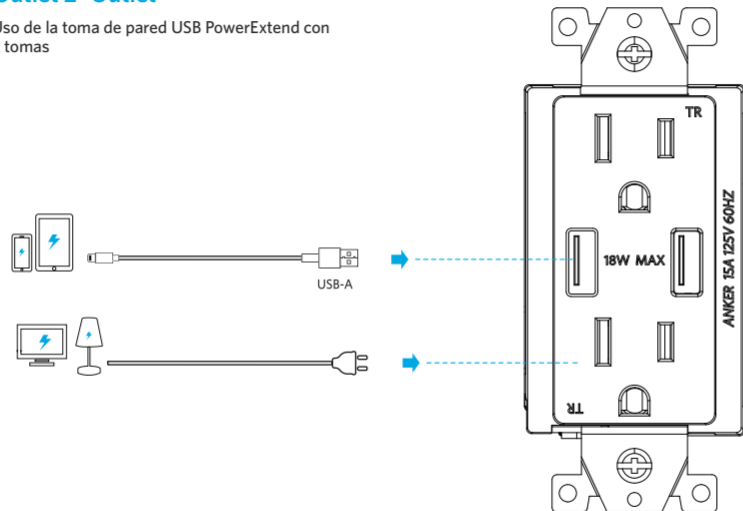

Product Number: A9321 51005002714 V01

## FCC Statement

This device complies with Part 15 of the FCC Rules. Operation is subject to the following two conditions:

- (1) This device may not cause harmful interference, and
- (2) This device must accept any interference received, including interference that may cause undesired operation.

Warning: Changes or modifications not expressly approved by the party responsible for compliance could void the user's authority to operate the equipment.

**Note:** This equipment has been tested and found to comply with the limits for a Class B digital device, pursuant to Part 15 of the FCC Rules. These limits are designed to provide reasonable protection against harmful interference in a residential installation.

This equipment generates, uses, and can radiate radio frequency energy and, if not installed and used in accordance with the instructions, may cause harmful interference to radio communications. However, there is no guarantee that interference will not occur in a particular installation. If this equipment does cause harmful interference to radio or television reception, which can be determined by turning the equipment off and on, the user is encouraged to try to correct the interference by one or more of the following measures:

- (1) Reorient or relocate the receiving antenna.
- (2) Increase the separation between the equipment and receiver.
- (3) Connect the equipment into an outlet on a circuit different from that to which the receiver is connected.

(4) Consult the dealer or an experienced radio / TV technician for help.

The following importer is the responsible party:

Company Name: Fantasia Trading LLC

Address: 5350 Ontario Mills Pkwy, Suite 100, Ontario, CA 91764

Telephone: 1-800-988-7973

## Customer Service

ES: Atención al Client



EN: 18-month limited warranty\*  
ES: Garantía limitada de 18 meses\*

\*EN: Please note that your rights under applicable law governing the sale of consumer goods remain unaffected by the warranties given in this Limited Warranty.

ES: Tenga en cuenta que los derechos que le conceden las leyes aplicables que rigen la venta de bienes de consumo no se ven afectados por las garantías que proporciona esta garantía limitada.



EN: Lifetime technical support  
ES: Asistencia técnica de por vid



support@anker.com



(US) +1 (800) 988 7973 Mon - Fri 9:00am - 5:00pm (PT)  
(UK) +44 (0) 1604 936200 Mon - Fri 6:00 - 11:00 (GMT)  
(DE) +49 (0) 69 9579 7960 Mo - Fr 6:00 - 11:00  
(日本) +81 03 4455 7823 月 - 金 9:00 - 17:00  
(中国) +86 400 0550 036 周一至周五 9:00 - 17:30