

iPad® At A Glance

iPad®

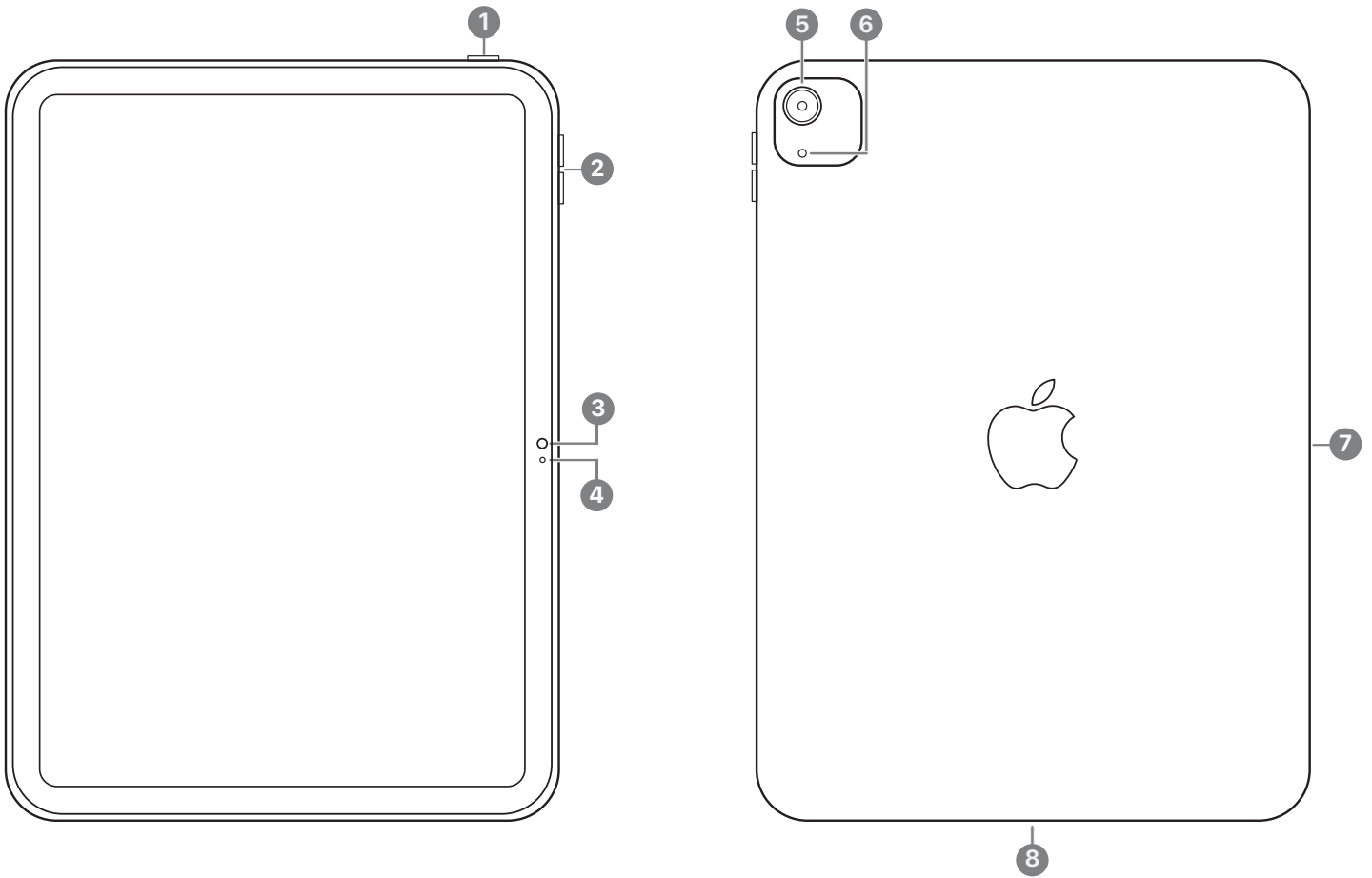

- ① Top button/Touch ID
- ② Volume buttons
- ③ Front camera
- ④ Microphone

- ⑤ Rear camera
- ⑥ Microphone
- ⑦ Smart Connector
- ⑧ USB-C connector

Sleep/Wake Button

You can lock the iPad® and put it to sleep when you're not using it. Locking the iPad® puts the display to sleep, saves the battery, and prevents anything from happening if you touch the screen. You still get FaceTime calls, text messages, alarms, and notifications, and can listen to music and adjust the volume.



Lock iPad®. Press the Sleep/Wake button.

Unlock iPad®. Press the Sleep/Wake button.

For additional security, you can require a passcode to unlock the iPad®. Go to Settings>Touch ID & Passcode (iPad® models with Touch ID) or Settings>Passcode (other models).

Turn iPad® on. Hold down the Sleep/Wake button until the Apple® logo appears.

Turn iPad® off. Hold down the Sleep/Wake button for a few seconds until the red slider appears on screen, then drag the slider.

If you don't touch the screen for two minutes, the iPad® locks itself. You can change how long the iPad® waits to lock itself, or set a passcode to unlock the iPad®.

Set the auto-lock time. Go to Settings > General > Auto-Lock.

Set a passcode. Go to Settings > General > Passcode Lock.

Go to the Home screen. Swipe up from the bottom edge of the screen.

On the Home screen, tap an app to open it.

See apps you've opened. Swipe up from the bottom of the screen, then pause in the center of the screen.

Use Siri (iPad® 3rd Generation or later). Press and hold the Sleep/Wake. When Siri appears, ask Siri a question or to do a task for you.

Volume Buttons

Use the Volume buttons to adjust the volume of songs and other media, and of alerts and sound effects.



Adjust the volume. Press the Volume buttons.

- *Mute the sound:* Press and hold the Volume Down button.
- *Set a volume limit:* Go to Settings > Music > Volume Limit.

You can also use Do Not Disturb to silence FaceTime calls, alerts, and notifications.

Set the iPad® to Do Not Disturb: Swipe down from the upper right corner of the screen to open Control Center, then tap . Do Not Disturb keeps alerts and notifications from making any sounds or lighting up the screen when the screen is locked. Alarms, however, still sound. If the screen is unlocked, Do Not Disturb has no effect. To schedule quiet hours, allow FaceTime calls from specific people, or allow repeated FaceTime calls to ring through, go to Settings > Do Not Disturb.

Multi-Touch Screen

A few simple gestures—tap, drag, swipe, and pinch—are all you need to use the iPad® and its apps.

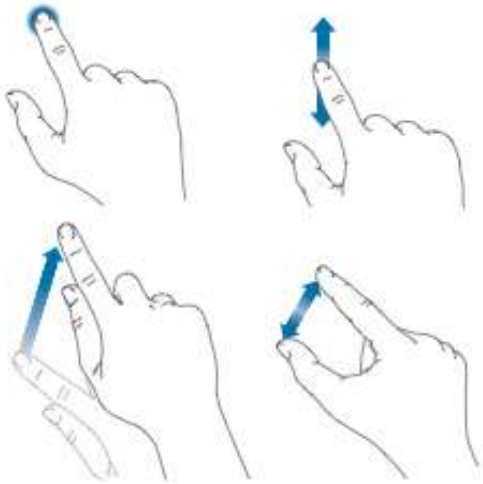

Accessories

The following accessories are included with the iPad®:

USB-C Power Adapter

Use with the USB-C Charging Cable to charge the iPad® battery.

USB-C Charging Cable

Use this cable to connect the iPad® to the USB-C Power Adapter or your computer.

- ① USB-C Power Adapter
- ② USB-C Charging Cable
- ③ Stylus

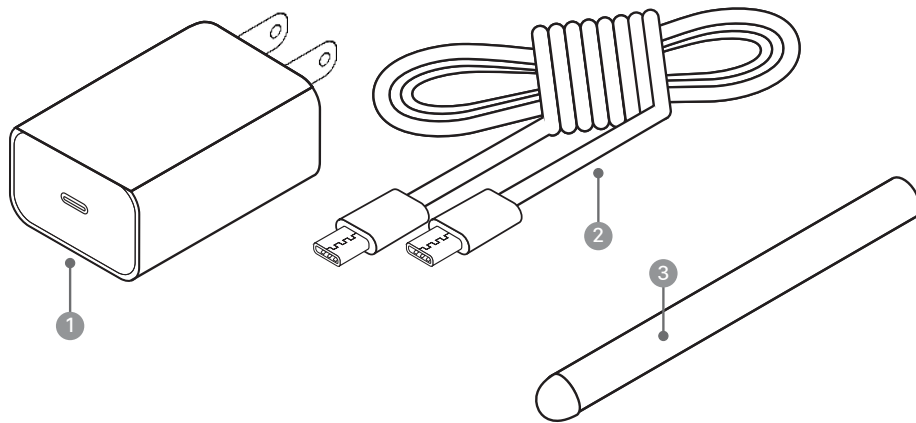

Otterbox Protective Case

You MUST keep the Otterbox Protective Case on the device at all times.



Apps

Includes Deaf Communication apps.