

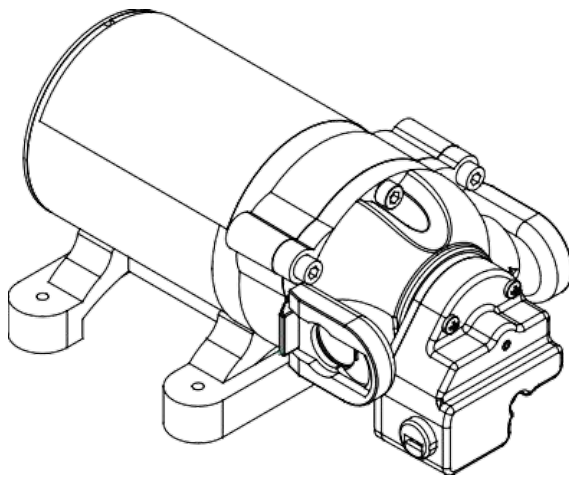

12V RV WATER PUMP

OWNER'S MANUAL



7.6LPM

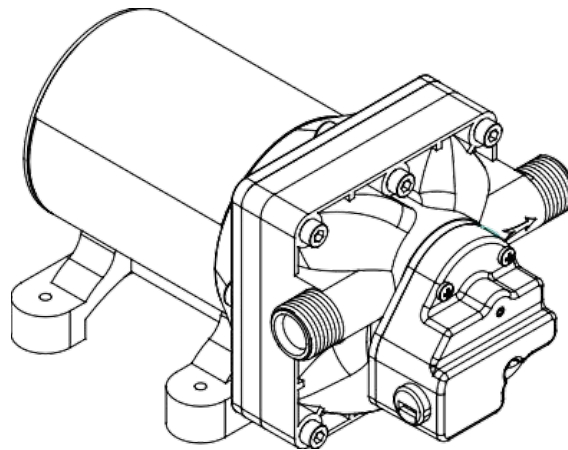

11.4LPM



Read this installation instruction thoroughly.
Incorrect installation or operation may void any warranty.
Incorrect use or operation may cause serious injury.

INSTRUCTIONS FOR INSTALLATION, TESTING, OPERATION, SERVICING, AND STORAGE

12V RV Pump: For use in RVs to transfer potable water, indoor use only.

WARNING

READ and **UNDERSTAND** the *Owner's Manual* completely **before using this potable water pump**. Install, test, and use only in accordance with the Owner's Manual instructions. **WEAR personal protective gear when filling, using, cleaning, and servicing the water pump.**

DO NOT START water pump until ready to use to avoid unintentional distribution.

FOR INDOOR USE ONLY.

ALWAYS keep a fire extinguisher nearby.

Improper use of the water pump could result in serious injury to the operator or nearby persons/animals or could cause damage.

HAZARD SIGNAL WORD DEFINITIONS

HAZARD SIGNAL	DEFINITION
	This is the safety alert symbol. It is used to alert you to potential personal injury hazards. Obey all safety messages that follow this symbol to avoid possible injury or death.
DANGER	DANGER (red) indicates an imminently hazardous situation which, if not avoided, will result in death or serious injury.
WARNING	WARNING (orange) indicates a potentially hazardous situation which, if not avoided, could result in death or serious injury.
CAUTION	CAUTION (yellow) indicates a potentially hazardous situation which, if not avoided, may result in minor or moderate injury.
CAUTION	CAUTION (yellow) used without the safety alert symbol indicates a potentially hazardous situation which, if not avoided, may result in property damage.

1300 663 868 | enquiries@aussietraveller.com.au | aussietraveller.com.au

BRISBANE SHOWROOM: 11-15 Oasis Court, Clontarf QLD 4019 | **MELBOURNE SHOWROOM:** 235 Barry Road, Campbellfield VIC 3061

TABLE OF CONTENTS

INTENDED USE	3
SUMMARY OF IMPORTANT SAFETY INFORMATION	4
Before Installation	
During Installation	
General Safety	
Operation	
Accident Procedures	
WARNING LABEL LOCATION	5
INSTALLATION	7
Step One: Prepare for Installation	7
Step Two: Mounting	7
Step Three: Plumbing	7
Step Four: Connect pump to 12V DC power supply	8
Step Five: Check and test the installation of the pump	10
OPERATION	11
Preparing the Pump for Use	11
Using the Pump	12
Step One: Operate the pump	12
Step Two: Clean pump after each use	13
STORAGE	13
Preparing for storage	13
Removing from storage	14
TROUBLESHOOTING	15
SPECIFICATIONS	17
ACCESSORIES	19
EXPLODED VIEWS	20
LIMITED WARRANTY	23

1300 663 868 | enquiries@aussietraveller.com.au | aussietraveller.com.au

BRISBANE SHOWROOM: 11-15 Oasis Court, Clontarf QLD 4019 | MELBOURNE SHOWROOM: 235 Barry Road, Campbellfield VIC 3061



INTENDED USE

The pump is intended for use in RVs to transfer potable/drinking water, for indoor use only.

The pump is intended for intermittent or continuous duty when the proper operating criteria is met.

The technical specifications for your pump are provided in the Specifications section of this manual.

Follow all safety precautions presented throughout the manual. A summary of important information can be found at the beginning of this manual.

EXAMPLE PLUMBING SCHEMATIC

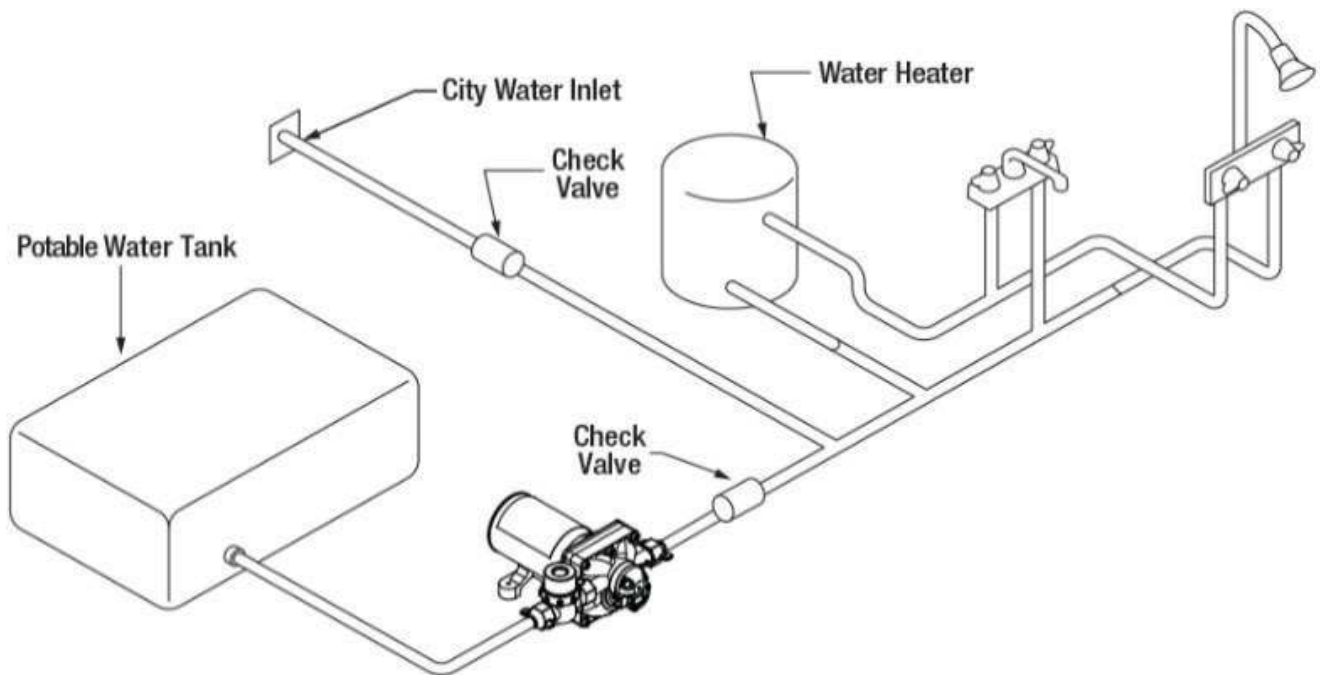

1300 663 868 | enquiries@aussietraveller.com.au | aussietraveller.com.au

BRISBANE SHOWROOM: 11-15 Oasis Court, Clontarf QLD 4019 | MELBOURNE SHOWROOM: 235 Barry Road, Campbellfield VIC 3061

SUMMARY OF IMPORTANT INFORMATION

⚠ WARNING:

Read and understand **this owner's manual** completely before using the pump, particularly the plumbing section.

Improper use of the pump could result in serious injury or illness for the operator or nearby persons/animals, or cause damage to the environment.

LISTED BELOW is a summary of safety information of particular importance. See individual sections of this owner's manual for more details.

BEFORE INSTALLATION:

- **READ** and **FOLLOW** the plumbing instructions and warnings in the RV Waterpump manual.
- **CHECK** for properly sized wiring and correct electrical protection.
- **CONFIRM** the mounting location will allow adequate ventilation to prevent overheating.
- **TURN** power **OFF** to the existing pump(s) and any live electrical circuits.
- **RELIEVE** system pressure.
- **DISCONNECT** the main power to the pump.

DURING INSTALLATION:

- **EXERCISE CAUTION** when attaching pump to 12 Vdc power supply. Follow the steps listed in the Installation section of this manual when connecting the pump to the power supply.
- **CHECK** and **TEST** installed pump as directed in this manual.
- **DO NOT MODIFY** pump design.

GENERAL SAFETY:

- **READ** and **FOLLOW** instructions and warnings in this manual.
- **READ** and **FOLLOW** instructions and warnings in the RV waterpump manual.
- **DO NOT USE** flammable or corrosive chemicals in this pump.

OPERATION:

BEFORE USE

- **INSPECT** and **PREPARE** pump before each use as directed in this manual.
- **DO NOT TURN ON POWER** to pump until ready to USE to avoid unintentional flow.

DURING USE

- **TURN OFF** power to pump and **RELIEVE** system pressure before leaving pump unattended.
- **SEE** Troubleshooting section of this manual before attempting any repairs. Wear personal protective equipment and follow safety instructions.

AFTER USE

- It is recommended that water supply lines and waterpump are flushed after use.

ACCIDENT PROCEDURES:

Immediate response is necessary in the event of a pump leak. See instructions below:

- **PUMP LEAK** - If the pump develops a leak, immediately stop using. Turn off power to the pump and refer to the troubleshooting section of this manual, as applicable.

1300 663 868 | enquiries@aussietraveller.com.au | aussietraveller.com.au

BRISBANE SHOWROOM: 11-15 Oasis Court, Clontarf QLD 4019 | MELBOURNE SHOWROOM: 235 Barry Road, Campbellfield VIC 3061

WARNING LABEL LOCATION

Always make sure warning labels are in place and in good condition. *If a warning label is missing or not legible, order new labels or unsafe operation could result. To order replacement warning labels, please call Aussie Traveller on 1300 663 868.*

⚠ WARNING <ul style="list-style-type: none">• Do not pump flammable liquids• Acceptable for indoor use only• Relieve system pressure before performing maintenance	⚠ AVERTISSEMENT <ul style="list-style-type: none">• Ne pas pomper de liquides inflammables• Acceptable uniquement pour une utilisation en intérieur• Relâchez la pression du système avant d'effectuer l'entretien
---	---

799657

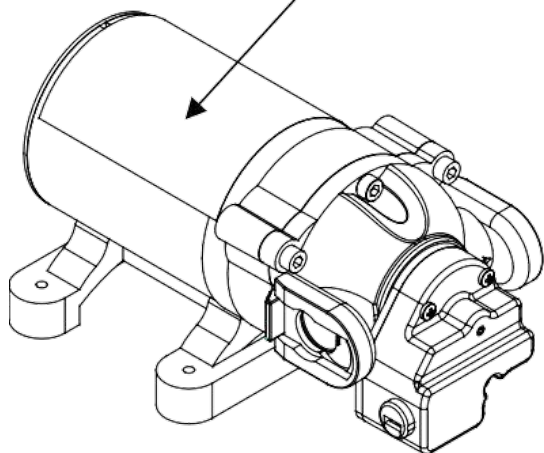

7.6LPM

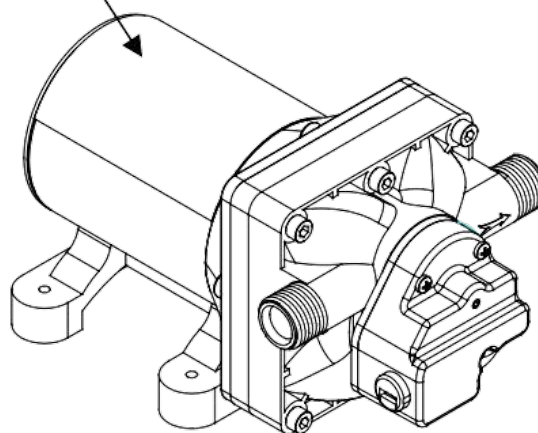

11.4LPM

1300 663 868 | enquiries@aussietraveller.com.au | aussietraveller.com.au

BRISBANE SHOWROOM: 11-15 Oasis Court, Clontarf QLD 4019 | MELBOURNE SHOWROOM: 235 Barry Road, Campbellfield VIC 3061

INSTALLATION

STEP ONE: PREPARE FOR INSTALLATION

- This pump is self-priming.
- The pump is for indoor use only and should be mounted on a solid surface in a location that is dry and provides adequate ventilation.

CAUTION

DO NOT locate the motor near plastics that could melt or combustible material. The surface temperature of the motor may exceed 93°C (200°F).

- Prior to installation ensure properly sized wiring, proper electrical protection and adequately sized plumbing lines and connections.

STEP TWO: MOUNTING

- The pump may be mounted in any horizontal position. If mounting the pump vertically, the pump head should be in the down position so that in the unlikely event of a leak, fluid will not enter the motor.
- Secure the rubber feet with #8 fasteners. DO NOT compress the feet, doing so will reduce their ability to isolate vibration/noise. (Note: fasteners are not included.)
- Mount pump within 1800mm (6 feet) of the tank for best pump performance and longer pump life.

STEP THREE: PLUMBING

See table below for port size and recommended hose sizes.

- Remove shipping plugs from pump ports.
- Use included swivel fittings to connect flexible high-pressure tubing to the NPS ported pumps.
- Use included quick connect fittings to connect flexible high-pressure tubing to the quick connect ported pumps.
- To insert quick connect fittings, lubricate O-ring with water and twist fitting while inserting into pump port.

MODEL	PORTS	MINIMUM INLET HOSE SIZE	MINIMUM OUTLET HOSE SIZE
7.6LPM	3/4" Quick Connect	1/2" (12mm) Inside diameter	1/2" (12mm) Inside diameter
11.4LPM	1/2" NPS – M	1/2" (12mm) Inside diameter	1/2" (12mm) Inside diameter

NOTE: We do not recommend the use of rigid pipe to plumb the inlet/outlet ports.

- Tubing/hose should be flexible, compatible with potable water and rated for the pump's maximum pressure. At least 450mm (18") length is suggested to minimize stress on the fitting/ports and reduce noise. Allow for the shortest possible tubing/hose route and avoid sharp bends that may kink over time.
- The tubing/hose should be anchored where it meets rigid pipe/hard plumbing to reduce vibration.
- Installation include potable water approved 50-mesh strainer is required to prevent foreign debris from entering the system.

NOTE: We do not recommend the use of rigid pipe to plumb the inlet/outlet ports.

- If a check valve is installed in the plumbing, it must have a cracking pressure of no more than 2 psi [.14 bar].

1300 663 868 | enquiries@aussietraveller.com.au | aussietraveller.com.au

BRISBANE SHOWROOM: 11-15 Oasis Court, Clontarf QLD 4019 | MELBOURNE SHOWROOM: 235 Barry Road, Campbellfield VIC 3061

INSTALLATION (CONTINUED)

STEP FOUR: CONNECT PUMP TO 12 VDC POWER SUPPLY

- This pump is self-priming.
- The pump is for indoor use only and should be mounted on a solid surface in a location that is dry and provides adequate ventilation.

⚠ WARNING

Caution must be exercised when making connections to a 12V DC power supply to avoid shock.

ALWAYS follow the safety instructions and steps listed below in exact sequence when connecting the pump to a 12V DC power supply.

1. PREPARATORY SAFETY

- ALWAYS use eye protection.
- NEVER smoke or work near sparks or other sources of ignition.

2. ELECTRICAL REQUIREMENTS

- The pump should be on a dedicated (individual) circuit, controlled with a double pole switch (CE/UL/CSA certified) rated at or above the fuse ampere indicated by the pump motor label. Depending on distance of the power source from the pump and ampere load on the circuit, wire may need to be heavier than indicated by the chart.
- Use an approved wire of the size specified below or heavier.

MODEL	VOLTAGE	FUSE AMP	WIRE LEADS	WIRE SIZE (STRANDED MTW)
7.6LPM	12V DC	10A	RED (positive +) BLACK (negative -)	#14 AWG (2.5mm ²) or heavier
11.4LPM	12V DC	10A	RED (positive +) BLACK (negative -)	#14 AWG (2.5mm ²) or heavier

3. CONNECT PUMP TO 12V DC POWER SUPPLY

Connect the pump to a 12V DC power supply using the following procedure:

- Strip off about 15mm (1/2") of insulation from the end of each power supply wire.
- Position the pump's **red wire** parallel with the **positive (+)** wire from power supply. Secure using a twist-on wire nut.
- Position the pump's **black wire** parallel to the **negative (-)** wire from the power supply. Secure using a twist-on wire nut.

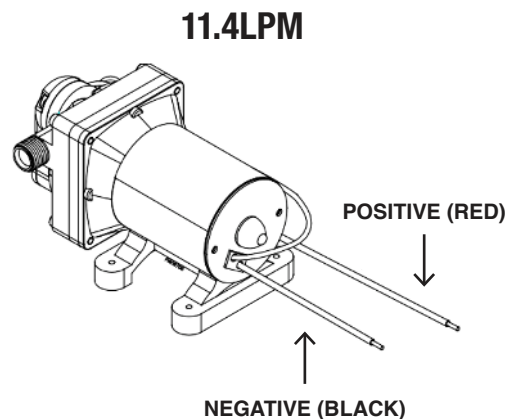
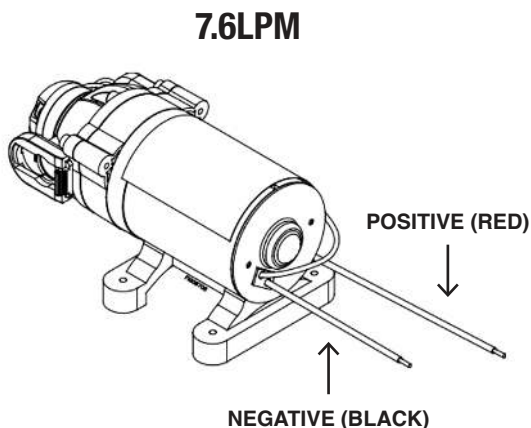

1300 663 868 | enquiries@aussietraveller.com.au | aussietraveller.com.au

BRISBANE SHOWROOM: 11-15 Oasis Court, Clontarf QLD 4019 | MELBOURNE SHOWROOM: 235 Barry Road, Campbellfield VIC 3061

INSTALLATION (CONTINUED)

STEP FIVE: CHECK AND TEST THE INSTALLATION OF THE PUMP

WARNING

- Serious injury could result from leaks if pump is improperly assembled, installed or the design of the pump is modified.
- Follow the steps below to ensure the pump is properly installed. Never modify the pump design.

1. CHECK INSTALLATION

Check installation to ensure the pump is properly mounted, wired, plumbed and in safe working condition.

2. ELECTRICAL REQUIREMENTS

Test the system for leaks with potable water:

- a. Fill the tank with CLEAN potable water.
- b. The pump is an “on demand” pump. When turned on, the pump will prime itself, then turn off once reaching pressure. When the demand for flow continues, the pump will automatically re-start.
- c. Check for leaks throughout the system. If a leak is detected, fix the leak and re-test the system with potable water.

OPERATION — PREPARING PUMP FOR USE

Inspect and prepare pump before each use.

WARNING

- Read instructions below carefully for inspecting and preparing the pump.
- Damaged or clogged equipment could result in leaks or uncontrolled distribution.
- Leaks could result in injury to the operator or bystanders.

IMPORTANT SAFETY RULES:

- **POWER OFF:** Make sure all power is OFF before cleaning, inspecting, or servicing the pump.
- **GUARDS / SHIELDS:** Make sure all guards and shields are replaced after servicing the pump.
- **REPLACEMENT PARTS:** If a part needs replacement, only use parts that meet the manufacturer’s specifications. Replacement parts that do not meet specifications may result in a safety hazard or poor operation of the pump.

1. ENSURE CLEAN SYSTEM

Ensure the pump has been thoroughly flushed, drained, and sanitised.

2. INSPECT & REPAIR

Ensure the pump has been thoroughly flushed, drained, and sanitised.

- a. Inspect hoses/lines for exposed mesh and holes. Replace all worn or damaged hoses/lines.
- b. Inspect fittings for cracks and leaks. Replace Aussie Traveller pump if needed.
- c. Partially fill system with **CLEAN** potable water and turn on to test for leaks. Repair as needed.

IMPORTANT: After any repair work has been done, ALWAYS test for leaks with potable water one final time before using.

1300 663 868 | enquiries@aussietraveller.com.au | aussietraveller.com.au

BRISBANE SHOWROOM: 11-15 Oasis Court, Clontarf QLD 4019 | MELBOURNE SHOWROOM: 235 Barry Road, Campbellfield VIC 3061

OPERATION — USING THE PUMP

STEP ONE: OPERATE THE PUMP:

WARNING

ALWAYS wear personal protective equipment when operating or servicing the pump.

1. REVIEW SAFETY INFORMATION

Review the Summary of Important Information section provided in this manual.

2. WEAR PERSONAL PROTECTIVE EQUIPMENT

Wear personal protective equipment as needed.

3. TURN ON POWER

Turn on the power to the pump.

NOTE: *The pump will start automatically when power is turned on. The pump will cycle on and off as needed to retain pressure in the hose.*

4. PRESSURE SWITCH OPERATION

The pressure switch reacts to outlet pressure, and interrupts power at the preset shut-off pressure indicated on the pump label. When outlet pressure drops below a predetermined limit the switch will close and the pump operates until the shut-off pressure is achieved. The shut-off pressure is set to factory calibrated standards.

NOTE: *If the plumbing is restrictive or the flow rate is very low, the pump may re-pressurize the outlet faster than the fluid is being released, causing rapid cycling (*ON/OFF within 2 seconds). If the pump is subjected to rapid cycling during normal operation, or for infrequent periods, damage may occur. Applications which exhibit rapid cycling should have restrictions in the outlet minimized.*

5. LEAVING UNATTENDED

If the pump must be left unattended at any time:

- a. Disconnect power to the pump.
- b. Relieve system pressure.

6. DISCONTINUE USE IF CLOGGED OR INOPERATIVE

If the pump becomes clogged or inoperative during use, discontinue use immediately.

- Do not attempt to service while water is in the pump and power is connected.
- Return to the troubleshooting section of this manual before attempting to service.

CAUTION

DO NOT operate the pump at pressures which cause the motor to exceed the amperes rating indicated on the name plate.

Improper adjustment of the pressure switch setting may cause severe overload or premature failure. Failures due to improper adjustment of the pressure switch setting will not be covered under the warranty.

1300 663 868 | enquiries@aussietraveller.com.au | aussietraveller.com.au

BRISBANE SHOWROOM: 11-15 Oasis Court, Clontarf QLD 4019 | MELBOURNE SHOWROOM: 235 Barry Road, Campbellfield VIC 3061

OPERATION — USING THE PUMP (CONTINUED)

STEP TWO: CLEAN PUMP AFTER EACH USE

The pump should always be stored indoors.

For long term or winter storage, prepare the pump by running RV antifreeze through the system. This will keep internal parts lubricated, protect against corrosion, and keep the unit from freezing.

CAUTION

- The pump will be damaged if it freezes.
- Protect the pump from freezing during storage by following the instructions below

STORAGE

PREPARING FOR STORAGE:

1. ADD ANTI-FREEZE

Pour RV antifreeze into the pump system.

NOTE: *RV antifreeze is non-toxic and biodegradable and generally safer for the environment than automotive antifreeze.*

2. OPERATE BRIEFLY

Turn on the pump and run the pump system briefly until fluid is distributed through plumbing system.

REMOVING FROM STORAGE:

1. DRAIN

Drain the antifreeze left in the plumbing system into a suitable container.

2. FLUSH WITH WATER

Fill the potable water tank with CLEAN potable water and run through the system. Operate the pump system until the system is completely flushed. Be sure to set up containers to capture the antifreeze flush water.

3. DISPOSAL

Dispose of the antifreeze and flush properly with potable water.

4. SANITISE

To ensure clean, safe drinking water, it is important for your health to sanitize the potable water system if the pump has been sitting in storage or has not been used for a while. The clean and grey water holding tank, hot water tank, and the water lines are potential places for bacteria to grow.

Before you start, read all of the instructions in this manual on how to properly sanitize the plumbing system.

Before you get started, there are some things to consider:

- You will need at least 5 to 10 hours of time to complete this task.
- Remove the water filters while sanitizing the water system and consider replacing the water filter when you have completed the sanitation.
- If you have a hot water tank, this is an ideal time to flush out the hot water tank.

1300 663 868 | enquiries@aussietraveller.com.au | aussietraveller.com.au

BRISBANE SHOWROOM: 11-15 Oasis Court, Clontarf QLD 4019 | MELBOURNE SHOWROOM: 235 Barry Road, Campbellfield VIC 3061

STORAGE (CONTINUED)

4. SANITISE (CONT.)

Sanitise your potable water system.

1. Determine the size of your water system, the potable water holding tank, plus the hot water tank and 15 litres for your water lines, depending on your set up. Refer to your owner's manual.
2. Prepare a 5% sodium-hypochlorite solution using chlorine bleach (non-scented and non-gel) and water. Use the chart below for mix concentrations.

FRESH WATER TANK SIZE	AMOUNT OF BLEACH	MIX INCLUDING WATER
40 gallons (152 litres)	1 cup (240 ml)	4 gallons (16 litres)
50 gallons (190 litres)	1 1/4 cup (300 ml)	5 gallons (20 litres)
60 gallons (227 litres)	1 1/2 cup (360 ml)	6 gallons (24 litres)
80 gallons (302 litres)	1 3/4 cup (420 ml)	7 gallons (28 litres)
100 gallons (380 litres)	2 cups (480 ml)	8 gallons (32 litres)

3. Add bleach mixture to the water tank – NEVER POUR STRAIGHT BLEACH INTO THE FRESH WATER TANK!
4. If you have a bypass for your hot water tank, make sure that is set for normal use so that the bleach mixture will be pumped through the hot water tank.
5. Top off the potable water tank with potable water.
6. Run the chlorinated water through all lines (hot and cold, one at a time) for one to two minutes. You should be able to smell the chlorine.
7. Top off the potable water tank again.
8. Let it sit for 4 hours minimum; overnight is best. The most important thing is to wait the appropriate amount of time for the tank to be properly sanitized.

NOTE: Doubling the bleach will not cut the time in half! Drain and rinse the water tank and water lines several times with fresh, CLEAN water. The water should now be safe to drink, but if the chlorine odour is too strong, add a mixture of 1/2 cup baking soda and a gallon of fresh water to the water tank and repeat the potable water flush.

1300 663 868 | enquiries@aussietraveller.com.au | aussietraveller.com.au

BRISBANE SHOWROOM: 11-15 Oasis Court, Clontarf QLD 4019 | MELBOURNE SHOWROOM: 235 Barry Road, Campbellfield VIC 3061

TROUBLESHOOTING

WARNING

Before troubleshooting or attempting to service, read the following safety rules to avoid risk of electric shock.

BEFORE ATTEMPTING TO SERVICE THE PUMP:

1. PERSONAL PROTECTIVE EQUIPMENT

Wear personal protective equipment while servicing your pump.

2. REVIEW TROUBLE SHOOTING TABLE

Review the troubleshooting table below for the type of problem you are experiencing. However, DO NOT attempt to repair until the steps listed below are followed.

3. EMPTY & FLUSH

Empty the pump system and flush the pump system with potable water as directed in the Storage section, removing from storage.

4. DISCONNECT POWER/RELIEVE PRESSURE

Disconnect power to the pump and be sure all system pressure is relieved.

5. PREFORM REPAIRS

Follow the directions provided in the troubleshooting table to repair the pump.

6. TEST AFTER SERVICING

After servicing, ALWAYS test the pump for leaks with potable water before using.

PROBLEM	CAUSE	SOLUTION
Pump will not turn on	Bad electrical connection	Check battery connections
	Short in wires	Check condition of wires
	Fuse blown (if applicable)	Replace fuse
	Locked drive	Replace pump
	Faulty pressure switch	Replace pump
	Incorrect voltage	Check voltage ($\pm 10\%$)
Pump will not prime	Out of water	Refill water tank
	Inlet air leak	Tighten hose clamps/Replace pump
	Inlet/Outlet tube restriction	Remove restriction
	Clogged intake valves	Remove obstruction
	Clogged intake tube	Remove obstruction
Low pressure/flow	Inlet air leak	Tighten hose clamps/Replace pump
	Worn diaphragm	Replace pump
	Worn valves	Replace pump
	Inlet/Outlet tube restriction	Remove restriction
	Incorrect voltage	Check voltage ($\pm 10\%$)
	Clogged intake valves	Remove obstruction
	Clogged intake tube	Remove obstruction
Pump leaks	Loose fasteners	Tighten fasteners
	Pump seals degraded	Replace pump
	Leak in diaphragm	Replace pump
Pump starts with faucets closed	Leak in the system	Tighten leaking hose clamps/fittings
	Faulty pressure switch	Replace pump
	Air trapped in system	Purge the air from the system
Rough operation	Flexible mounting surface	Mount pump on rigid surface
	Loose pump head	Tighten fasteners
	Compressed base feet	Decompress base feet
	Rigid plumbing	Plumb pump with flexible plumbing

1300 663 868 | enquiries@aussietraveller.com.au | aussietraveller.com.au

BRISBANE SHOWROOM: 11-15 Oasis Court, Clontarf QLD 4019 | MELBOURNE SHOWROOM: 235 Barry Road, Campbellfield VIC 3061

SPECIFICATIONS (CONTINUED)

MODEL	7.6LPM	11.4LPM
PART NUMBER	266701001	266701002
ELECTRICAL CONNECTION	12V DC	12V DC
AVERAGE OPERATING AMP DRAW	5.5 Amps	5.5 Amps
MAXIMUM AMP DRAW	9.5 Amps	9.5 Amps
MAXIMUM FLOW	2.0 GPM [7.6 LPM]	3.0 GPM [11.4 LPM]
MAXIMUM PRESSURE	60 PSI [4.1 bar]	55 PSI [3.8 bar]
PORTS	3/4" QC	1/2" NPS-M
OVERALL DIMENSIONS	209.4 × 105.6 × 101.6mm	209.9 × 125 × 110.5mm
WEIGHT	1.8kg	2.0kg

The noise emissions from this product do not exceed 70 dB(A).

1300 663 868 | enquiries@aussietraveller.com.au | aussietraveller.com.au

BRISBANE SHOWROOM: 11-15 Oasis Court, Clontarf QLD 4019 | MELBOURNE SHOWROOM: 235 Barry Road, Campbellfield VIC 3061



SPECIFICATIONS (CONTINUED)

TECHNICAL DRAWING

7.6LPM PART NUMBER: 266701001

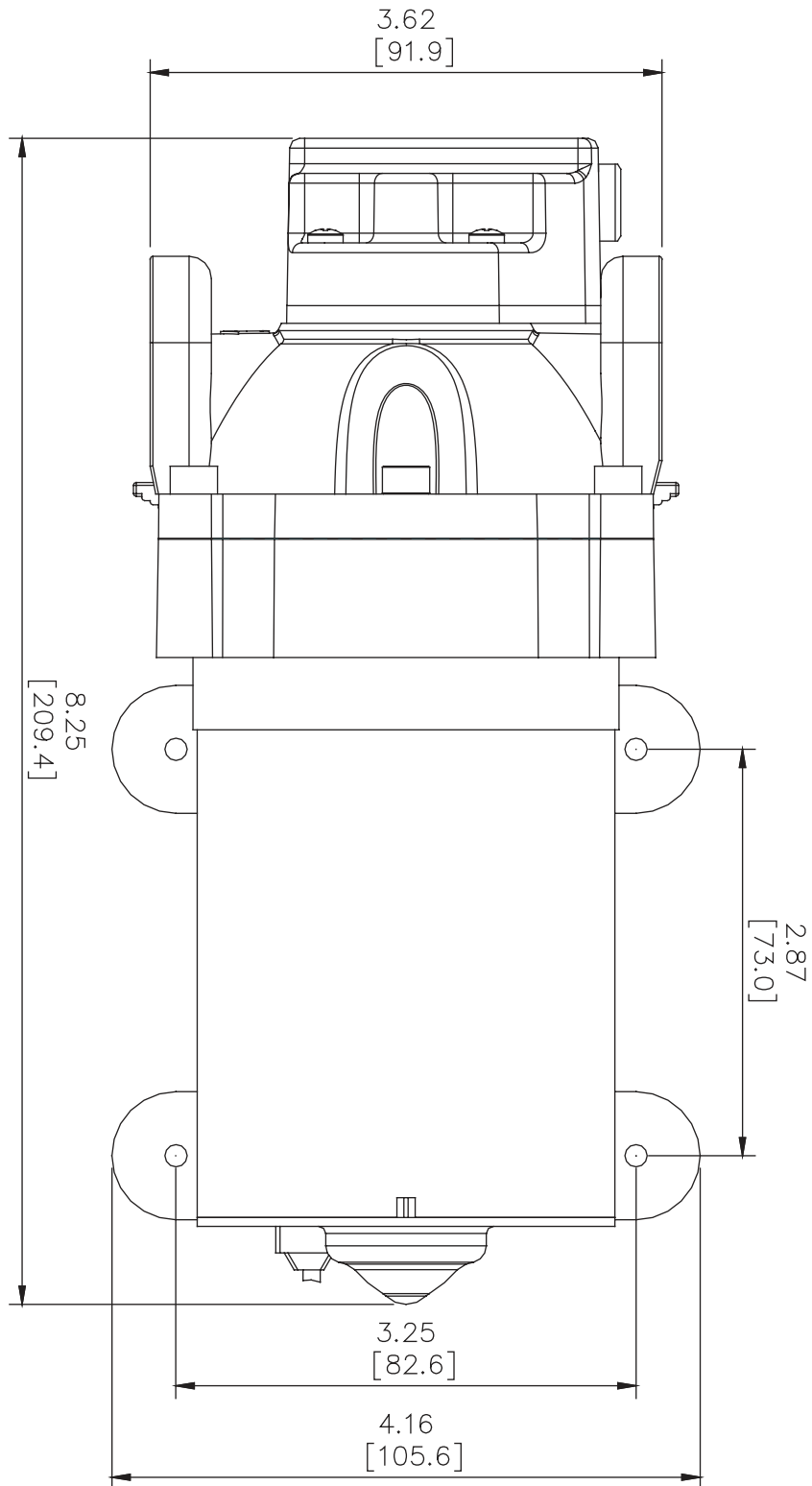

1300 663 868 | enquiries@aussietraveller.com.au | aussietraveller.com.au

BRISBANE SHOWROOM: 11-15 Oasis Court, Clontarf QLD 4019 | MELBOURNE SHOWROOM: 235 Barry Road, Campbellfield VIC 3061

SPECIFICATIONS (CONTINUED)

TECHNICAL DRAWING

11.4LPM PART NUMBER: 266701002

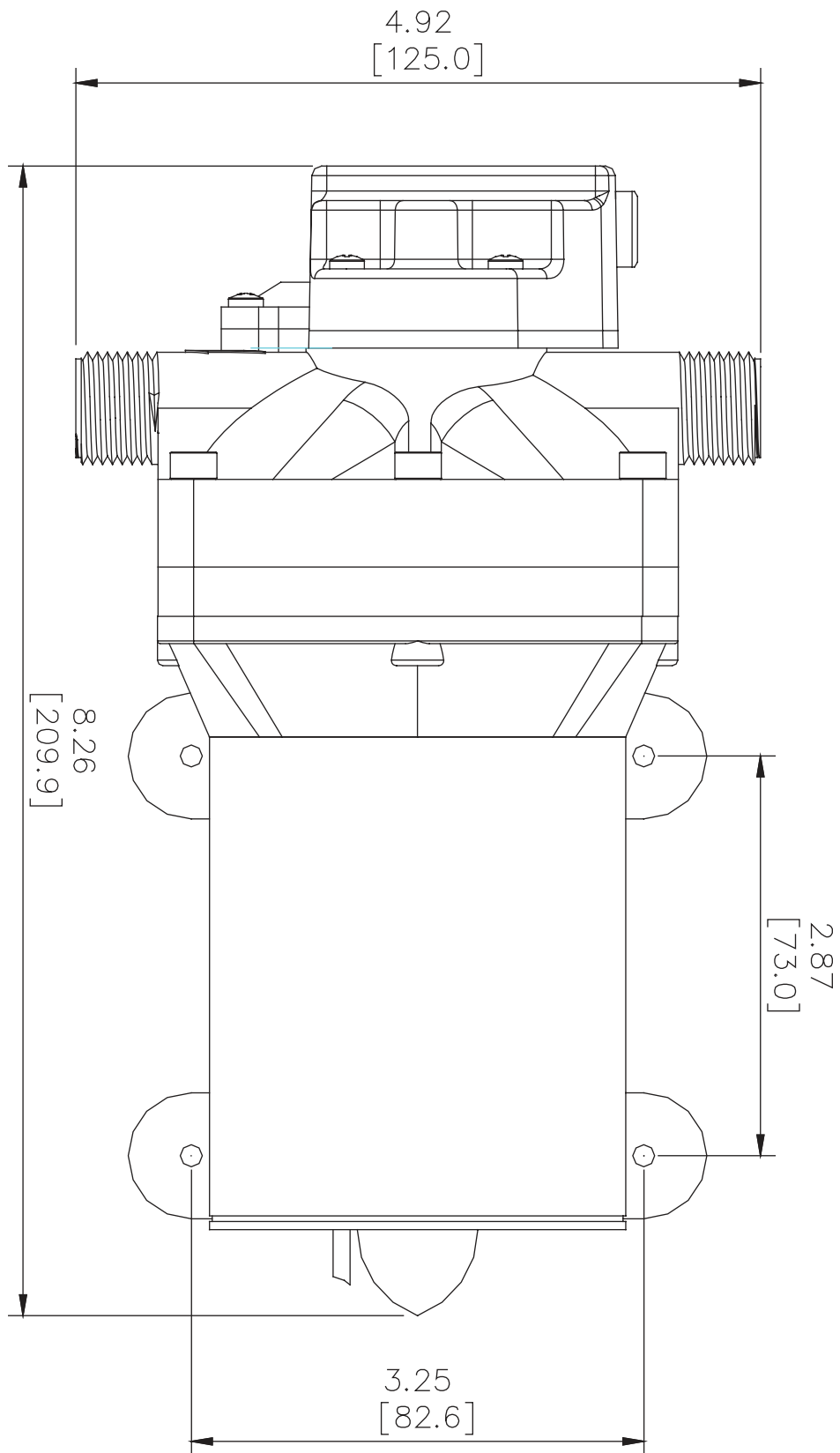

1300 663 868 | enquiries@aussietraveller.com.au | aussietraveller.com.au

BRISBANE SHOWROOM: 11-15 Oasis Court, Clontarf QLD 4019 | MELBOURNE SHOWROOM: 235 Barry Road, Campbellfield VIC 3061

ACCESSORIES

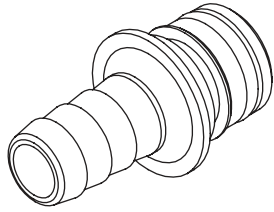

05100050001010

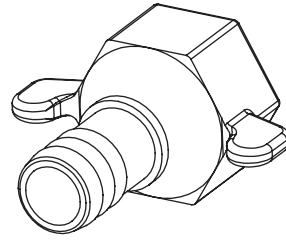

05100050004010

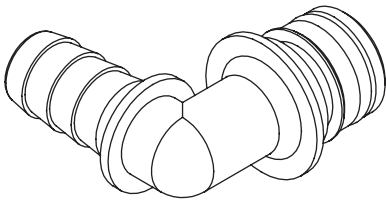

05100050001020

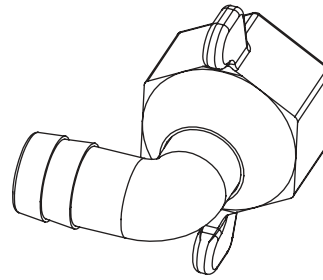

05100050004020

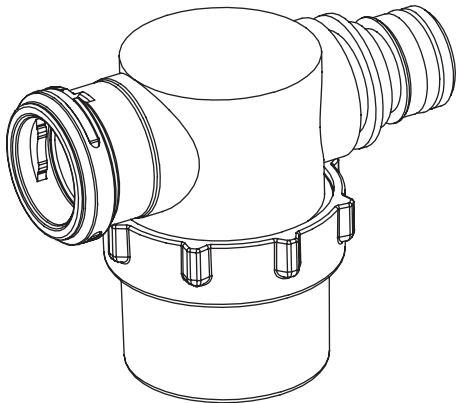

05100050001040

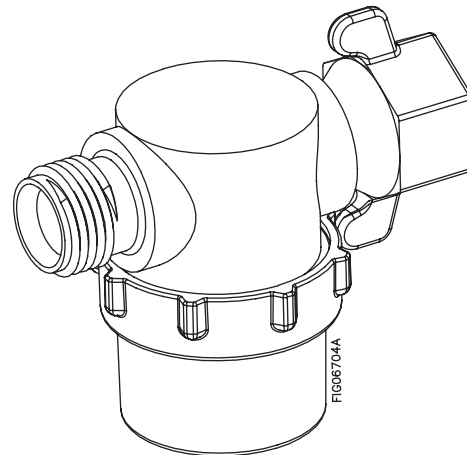

05100050004040

FIG06704A

PART NUMBER	DESCRIPTION	INCLUDED WITH MODEL
05100050001010	QC - 1/2" Hose Barb Straight Fit	7.6LPM
05100050001020	QC - 1/2" Hose Barb Elbow Fit	7.6LPM
05100050001040	QC - RV Pump Filter	7.6LPM
05100050004010	NPSM - 1/2" Hose Barb Straight Fit	11.4LPM
05100050004020	NPSM - 1/2" Hose Barb Elbow Fit	11.4LPM
05100050004040	NPSM - RV Pump Filter	11.4LPM

1300 663 868 | enquiries@aussietraveller.com.au | aussietraveller.com.au

BRISBANE SHOWROOM: 11-15 Oasis Court, Clontarf QLD 4019 | MELBOURNE SHOWROOM: 235 Barry Road, Campbellfield VIC 3061

EXPLODED VIEW - 7.6LPM

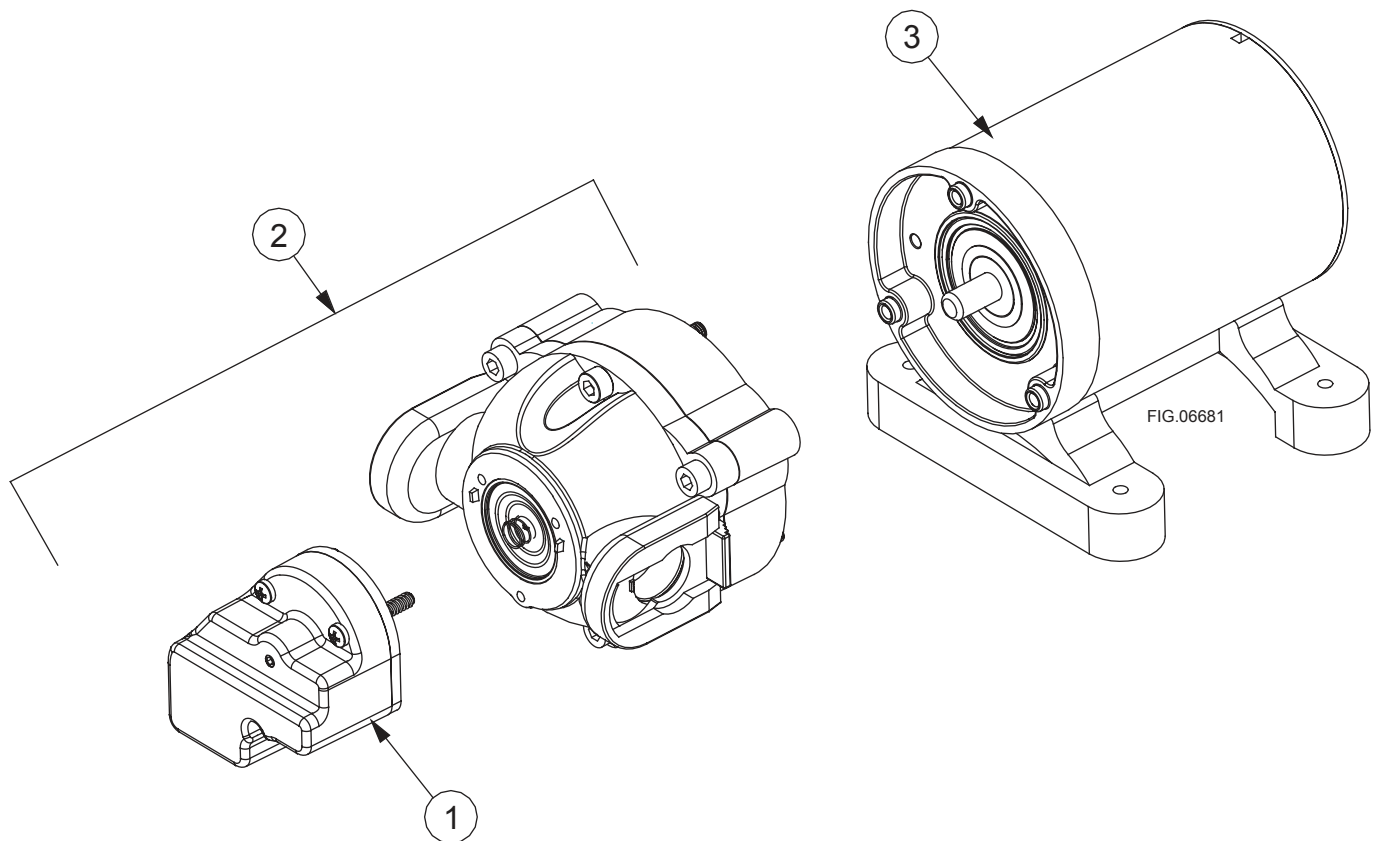

REFERENCE NUMBER	PART NUMBER	DESCRIPTION	QTY
1	801452	Pressure switch assembly	1
2	A2060R	Complete pump head assembly	1
3	789952	Motor assembly, 7.6LPM	1

1300 663 868 | enquiries@aussietraveller.com.au | aussietraveller.com.au

BRISBANE SHOWROOM: 11-15 Oasis Court, Clontarf QLD 4019 | MELBOURNE SHOWROOM: 235 Barry Road, Campbellfield VIC 3061

EXPLODED VIEW - 11.4LPM

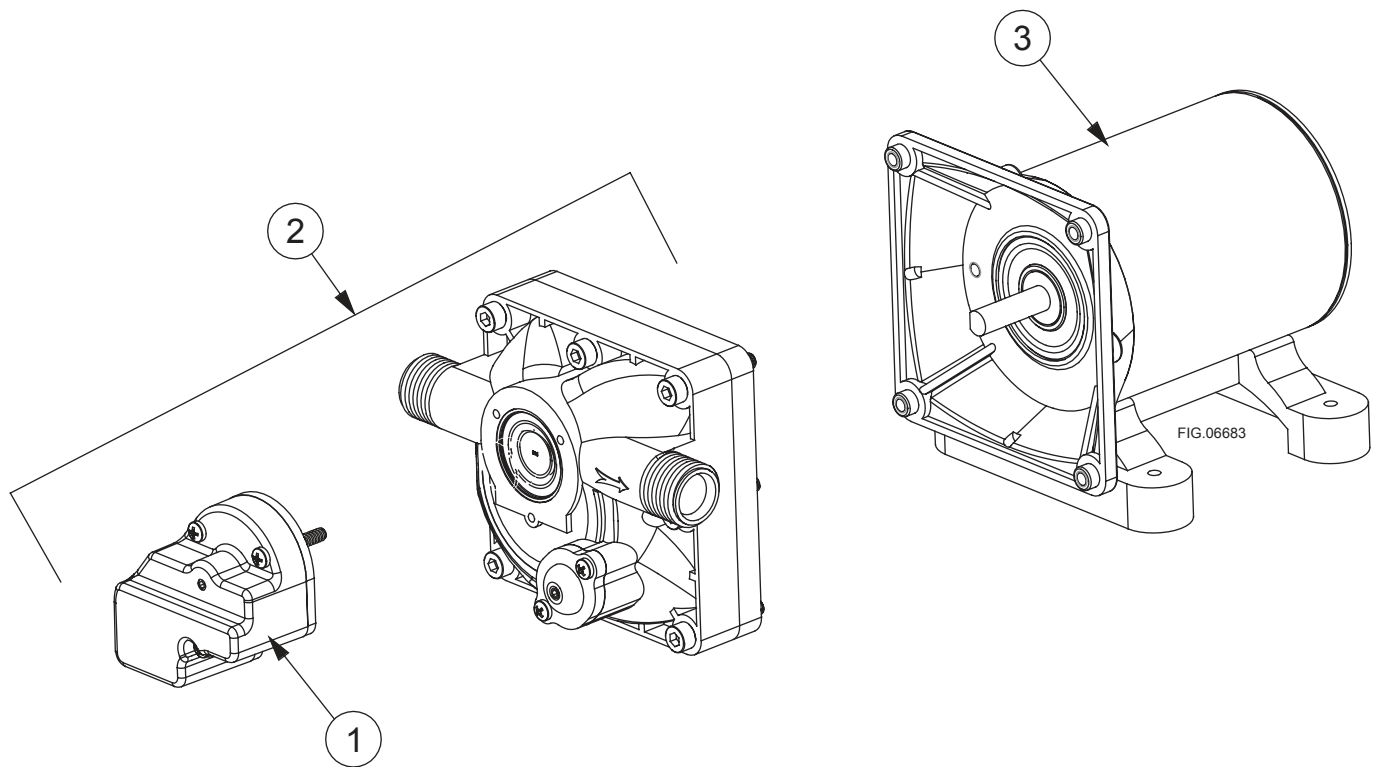

REFERENCE NUMBER	PART NUMBER	DESCRIPTION	QTY
1	801452	Pressure switch assembly	1
2	A3055R	Complete pump head assembly	1
3	789888	Motor assembly, 11.4LPM	1

1300 663 868 | enquiries@aussietraveller.com.au | aussietraveller.com.au

BRISBANE SHOWROOM: 11-15 Oasis Court, Clontarf QLD 4019 | MELBOURNE SHOWROOM: 235 Barry Road, Campbellfield VIC 3061

WARRANTY STATEMENT

Aussie Traveller Pty Ltd ACN 642 775 460 (**Aussie Traveller**) offers the following warranty in relation to the products it supplies directly or through an authorised manufacturer, dealer or approved service repair agent (**Product**).

Australian Consumer Law

The benefits of this warranty are in addition to any rights and remedies imposed by Australian State and Federal legislation that cannot be excluded. Nothing in this warranty is to be interpreted as excluding, restricting or modifying any State or Federal legislation applicable to the supply of goods and services which cannot be excluded, restricted or modified.

If you are a consumer as defined in the Australian Consumer Law: *Our goods come with guarantees that cannot be excluded under the Australian Consumer Law. You are entitled to a replacement or refund for a major failure and compensation for any other reasonably foreseeable loss or damage. You are also entitled to have the goods repaired or replaced if the goods fail to be of acceptable quality and the failure does not amount to a major failure.*

Warranty

Aussie Traveller warrants that, subject to the exclusions and limitations below, all parts of the manufacture and assembly of the Product will be free from defects in materials and workmanship (**Warranty**) for a period of 12 months from the date of purchase as follows:

1. This Warranty is activated at the time of purchase by the final retail customer (being the owner of the Product).
2. In the event the Product is purchased by a manufacturer, dealer or approved service repair agent, this Warranty will commence at the time the final retail customer makes payment for the Product to the wholesale purchaser.
3. If the Product is purchased directly from Aussie Traveller for use by final retail customer and not to be on sold in any way, the Warranty will commence at the time of the original purchase.

Warranty Period

This Warranty cannot be assigned or transferred to a subsequent owner of the Product.

The purchaser or final retail customer should inspect the Product immediately when received or at vehicle handover, to ensure that it appears free from any damage or defect, and matches the description provided.

If after accepting the Product, a defect appears in the manufacture or assembly of the Product before the end of the Warranty Period and Aussie Traveller finds the Product to be defective in materials or workmanship, Aussie Traveller will, in its sole discretion, either:

- a. replace, repair or refund the Product or the defective part of the Product free of charge; or
- b. cause the Product or the defective part of the Product to be replaced or repaired by a qualified repairer free of charge.

In arranging Warranty inspection, service and repair, Aussie Traveller will seek to provide the details of an approved service agent within your geographic area. Should one not be available, or if the Product is in use in travel, Aussie Traveller reserves the right to seek to arrange a repair or replacement at the next available location on the route of travel.

Aussie Traveller reserves the right to replace defective parts of the Product with parts and components of similar quality, grade and composition where an identical part or component is not available.

Products presented for repair may be replaced by refurbished goods of the same type rather than being repaired. Refurbished parts may be used to repair the Product.

Aussie Traveller Awning Products

This Warranty covers specified defects in materials or workmanship for Awning Products as follows:

1. The vinyl fabric is warranted against:
 - a. holes caused by mildew (mildew will form on dust and dirt and stain fabric if fabric is not kept clean).
 - b. excessive cracking, peeling, hardening or loss of strength while used under normal conditions.
 - c. excessive fading (a slight colour change may occur due to ultraviolet rays).
2. All hardware components including the roller are warranted not to bend or break under normal use (excluding high winds, water pooling and accidents).

Making a Warranty Claim

If a defect covered by this Warranty appears, the Customer must first contact Aussie Traveller within 7 days of first becoming aware of the defect. Aussie Traveller will assist the Customer to rectify and resolve any Product issue that may arise.

When making a claim under this Warranty, Aussie Traveller requires that the following information be provided before any further action will be taken.

1. Original Invoice (Document or Number);
2. Make and model of the Product;
3. Make and model of the vehicle (if Product fitted);
4. Vehicle build date (if Product fitted);
5. Vehicle chassis number;

6. Description of damage and/or repair required;
7. Photos of the damage and/or repair; and
8. Appropriate documentation (such as historical and maintenance records).

Aussie Traveller reserves the right to request more information or images should what is provided not be sufficient to make an assessment for the Warranty claim.

The Product must be made available to Aussie Traveller or its authorised repair agent for inspection and testing. If such inspection and testing find no defect in the Product, the final retail customer must pay Aussie Traveller's usual costs of service work and testing.

The final retail customer must bear the cost of the transport of the Product to and from Aussie Traveller or the authorised repair agent, and all insurance of the Product.

Exclusions

This Warranty will not apply where:

- the Product has been repaired, altered or modified by someone other than Aussie Traveller, or without the written consent of Aussie Traveller or an authorised repair agent;
- the alleged defect in the Product is within acceptable industry tolerances and variances;
- Aussie Traveller cannot establish any fault in the Product after testing and inspection;
- the Product has been used other than for the purpose for which it was designed;
- the alleged defect in the Product has arisen due to the final retail customer's failure to properly use and
- maintain the Product in accordance with any of Aussie Traveller's instructions, recommendations and specifications (including applicable maintenance schedules);
- the alleged defect in the Product has arisen due to the final retail customer's request to customise the Product;
- the Product has been subject to abnormal conditions, including environment, temperature, high or excessive wind, water, fire, humidity, pressure, stress or similar;
- the alleged defect has arisen due to abuse, misuse, neglect or accident;
- unauthorised parts or accessories have been used on or in relation to the Product;
- the Product has been overloaded or involved in an accident;
- the alleged damage or defect has been caused by normal wear and tear;
- the alleged damage to fabric has been caused by storm, wind or rain, or stretching of fabric caused by water pooling on fabric;
- breakage or bending of hardware components has been caused by storm, wind or rain, or water pooling on fabric.

Replacement Warranty Item

If, under Warranty, a Product is replaced or repaired by Aussie Traveller or an Aussie Traveller agent, unless provided in writing to indicate otherwise, the replacement Product will carry the **remaining** Warranty terms and conditions, including length of time, of the original purchased Product.

Change of Mind

Aussie Traveller understands that at times, final retail customers may change their mind. Choose carefully as return and credit requests for items purchased by mistake or "change of mind" reasons may not be approved. Aussie Traveller will not accept Product returns under these circumstances unless by written approval by an authorized Aussie Traveller representative. If approved, an administration and restocking fee may apply.

Limitations

Aussie Traveller makes no express warranties or representations other than set out in this Warranty.

The repair or replacement of the Product or part of the Product is the absolute limit of Aussie Traveller's liability under this express Warranty.

Contact

Australia Wide: 1300 663 868

Melbourne Office
235 Barry Road
Campbellfield, Melbourne, 3061
Ph: +61 3 9357 6565
enquiries@aussietraveller.com.au

Brisbane Head Office, Factory & Showroom
11-15 Oasis Court
Clontarf, Brisbane, 4019
Ph: +61 7 3284 3284
enquiries@aussietraveller.com.au

To receive a copy of the Aussie Traveller Warranty Terms & Conditions or information regarding specific Aussie Traveller products, please contact Aussie Traveller Head Office on (07) 3284 3284 or email enquiries@aussietraveller.com.au.