



Strip Warmers

Base Models: _____

177SW24INCPA, 177SW24TCPA, 177SW36INCPA, 177SW36INHA, 177SW36TCPA, 177SW36THA,
177SW48INCPA, 177SW48INHA, 177SW48TCPA, 177SW48THA, 177SW60INCPA, 177SW60INHA,
177SW60TCPA, 177SW60THA

Note:

Retain this manual for future reference. Unit must be kept clear of combustibles at all times. This unit must be serviced by qualified personnel only. Service by unqualified personnel may lead to electric shock or burn.

Table of Contents

Caution / Hazard Statements	3
Initial Setup	4
Installation	4-6
Operation	7
Cleaning.....	7
Maintenance	7-8
Troubleshooting.....	9

Introduction

Avantco Equipment Strip Warmers are designed to keep foods at optimum serving temperatures without affecting quality. They are built for tough kitchen duty with durable stainless steel construction, thick insulation, and easy-to-use toggle or infinite controls.

This manual provides the installation, safety, and operating instructions for Strip Warmers. Avantco Equipment recommends all installation, operating, and safety instructions appearing in this manual be read prior to installation or operation of the unit.



Conforms to NSF-4



Conforms to UL-197

Caution/Hazard Statements

ServIt Strip Warmers are designed, built, and sold for commercial use and should be operated by trained personnel only. Clearly post all CAUTIONS, WARNINGS, and OPERATING INSTRUCTIONS near each unit to ensure proper operation and to reduce the chance of personal injury and/or equipment damage.

- **READ THE MANUAL:** Thoroughly read and understand the manual before setting up, operating, or cleaning the strip warmer.
- **ELECTRICAL CONNECTIONS:** Hardwired electrical connections must be completed by a certified and insured electrician.
- **DEDICATED CIRCUIT:** For optimal performance and safety, the strip warmer must be connected to a dedicated electrical circuit. Sharing a circuit with other appliances can lead to power fluctuations, potential tripping of the circuit breaker, and a reduced lifespan of the unit.
- **PROPER VOLTAGE:** Plug the range into a grounded outlet with the correct voltage to prevent electrical hazards. The plug that comes pre-attached cannot be replaced without professional installation. Never operate the range using an extension cord.
- **CHILD SAFETY:** Keep children away from the strip warmer and its controls to prevent accidents and misuse.
- **CORD SAFETY:** Keep cords away from wet areas and do not let them hang over counters to prevent tripping hazards. Risk of fire and electric shock. Replace only with the manufacturer's cord set. Do not operate any appliance with a damaged cord or plug, after the appliance malfunctions, or if the appliance has been dropped or damaged. If the appliance has been dropped or damaged, return appliance to an authorized service facility for examination and repair.
- **CLEANING AND MAINTENANCE:** Regularly clean and maintain the strip warmer according to the instructions to ensure safe and hygienic operation.
- **CHEMICAL USAGE:** If using cleaning chemicals, follow the guidelines for safe handling and storage.
- **INSTRUCTION AND TRAINING:** Train users in safe and correct strip warmer operation.
- **SANITIZATION:** After cleaning, ensure the strip warmer is sanitized to prevent food contamination.
- **ELEMENT CHECK:** Inspect the heating elements regularly for proper function and absence of damage.
- **NO MODIFICATIONS:** Avoid modifying the strip warmer's components or features, as this may compromise safety and void warranties.
- **EMERGENCY PROCEDURES:** Know how to turn off the strip warmer quickly in case of emergencies or malfunctions.
- **INSTRUCTION LABELS:** Ensure any operational or safety labels on the strip warmer are visible and legible.
- **REGULAR INSPECTION:** Regularly inspect the strip warmer for signs of wear, damage, or malfunction, and address any issues promptly.
- **MAINTENANCE SCHEDULE:** Follow a maintenance schedule as recommended by the "Maintenance" section to ensure the strip warmer's longevity and safety.
- **PROPER USAGE:** Teach users how to properly use the strip warmer to prevent mishaps and ensure consistent cooking results

WARNING: All power must be disconnected at power source before any service procedure is performed.

WARNING: Do not use outdoors. This appliance is not intended for wet or moist locations. Never locate appliance where it may fall into water.

Initial Setup

INSPECT THE PACKAGING: Examine the exterior of the packaging for any signs of damage that might have occurred during shipping.

- **UNBOXING:** Open the packaging with care. Use scissors or a box cutter to cut open the box, ensuring you do not damage the strip warmer or its components.
- **REMOVE ALL COMPONENTS:** Extract the equipment and any included accessories from the box.
- **WIPE DOWN:** Wipe down the strip warmer prior to first use.
- **ADDITIONAL ACCESSORIES:** Some strip warmers come with additional accessories like chains, mounting brackets, and sneeze guards. Familiarize yourself with their proper placement and use. These accessories can all be purchased separately. See installation instructions for how to install these accessories.
- **SPACE TO BREATHE:** This strip warmer needs at least 10" of clearance from food for adequate ventilation. Strip warmers generate heat, and maintaining proper ventilation is vital for consistent performance and the appliance's longevity. See installation instructions below.
- **PROFESSIONAL INSTALLATION:** If the strip warmer is hardwired, a certified and insured foodservice equipment technician is required to install.

Installation

General Installation

- Do not install strip warmers less than 12" above combustible surfaces. Install strip warmer with a minimum distance of 3" from a combustible wall or adjacent surface. Failure to provide proper spacing may result in heat damage to electrical components.
- Depending on your model, 10" - 18" is the recommended mounting height. See below diagrams for reference.
- Installation of two or more separate units with less than 3" between housing may result in premature failure of component parts. Failure to provide proper spacing may result in heat damage to electrical components.

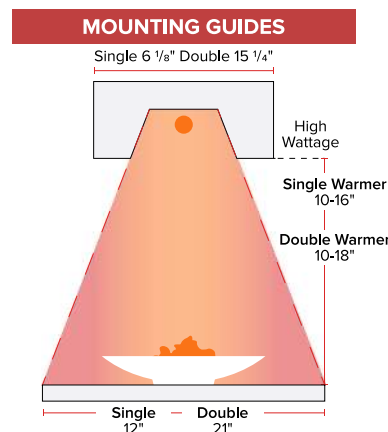
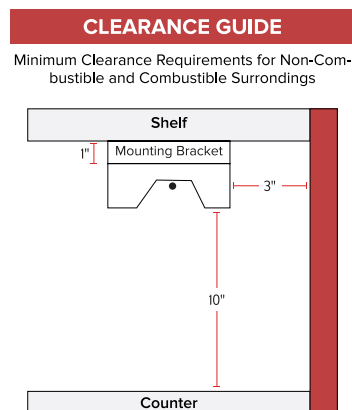

Under Shelf Mounting Installation Instructions

- When mounting a unit under a shelf, use the adjustable angle bracket to ensure proper spacing.
- Strip warmers can be mounted to the underside of a shelf with a minimum gap of 1" to protect electrical system.

Use the following procedure to install adjustable brackets on each end of the aluminum housing models:

1. Position the unit on a flat surface with the heating element facing down.
2. Remove the two hanger tab screws and hanger tabs. These items will not be needed.
3. Remove the two upper plate screws.
4. Align the adjustable angle bracket with the end plate mounting holes on the unit. Secure the angle bracket with the previously removed end plate screws.
5. Fasten the angle brackets the underside of the shelf using appropriate fasteners. See below diagram for reference.
6. Drill four holes on the underside of a shelf, use fasteners to install the brackets to the underside of the shelf.

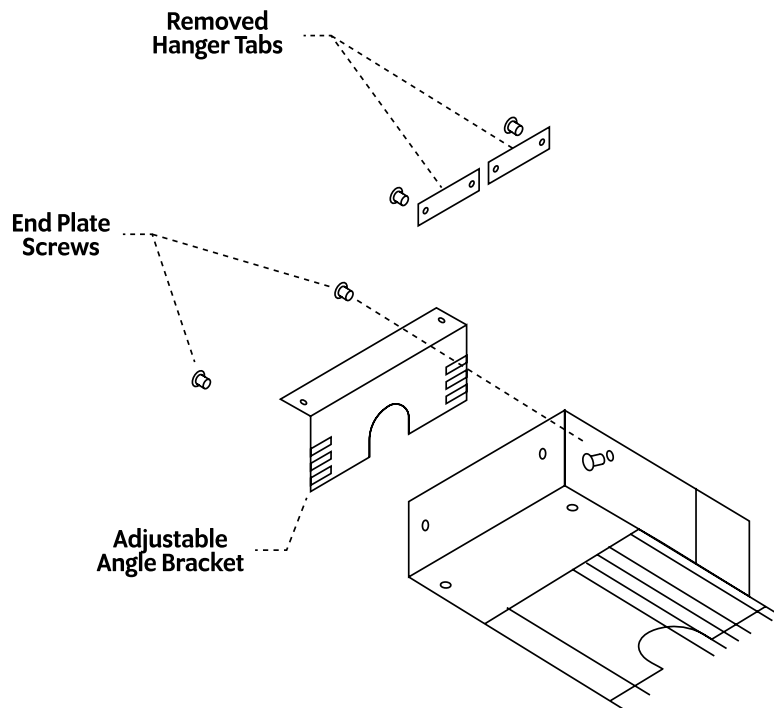

Installing Chain-Suspended Units

1. Prepare the overhead mounting system for the “S” hooks. Ensure the system is secure and is set up so the unit will be suspended at a level, safe, and proper distance from walls, counters, and food.
2. Loosen, but do not remove, the screws securing the hanger tabs on each end of the unit. Rotate the tabs up, then tighten the screws securely.
3. Securely attach one of the 6" (152 mm) connecting chains between each pair of hanger tabs.
4. Attach an “S” hook to the center of each connecting chain.
5. Carefully lift the unit and attach the “S” hooks on each end of the unit to the overhead mounting system. Ensure the unit is level. See diagram for reference.

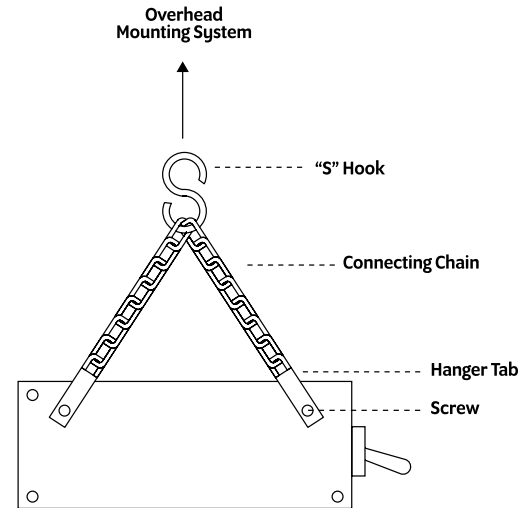

“S” Hook Mounting

Installing Optional Accessories and Legs

- Optional C-Legs or T-Legs (purchased separately) can be installed on all models for portable use. Only 120V models with a power cord and plug connection should be mounted onto T-Legs or C-Legs. Do not mount units longer than 72” on T-Legs or C-Legs.
1. Position the unit on a flat surface with the heating element facing up.
 2. Remove the two hanger tab screws and hanger tabs. These items will not be needed.
 3. Remove the two upper plate screws.
 4. Align the mounting holes on the legs with the end plate mounting holes on the unit. Secure the legs with the previously removed end plate screws.

Operation

Start-Up Procedure

If strip warmer comes with a cord and plug, plug the cord into grounded electrical outlet of the correct voltage. Electrical shock can occur if appliance is not grounded.

- For strip warmers with toggle controls, flip the switch to the “ON” position. Turn units “OFF” when not in use.
- For strip warmers with infinite controls, the control dial is used as the “ON” switch and to set the desired setting. Rotate dial to desired setting that works best for the food you are serving. The indicator light illuminates while strip warmer is on and shuts off when power is off.

Cleaning

Cleaning and Maintenance Instructions:

- **UNPLUG:** Always unplug the strip warmer from the electrical outlet before cleaning for safety purposes, minimizing the risk of electrical shocks.
- **GLOVES:** Wearing gloves is recommended. This helps protect your hands from grease and/or any sharp edges and keeps the strip warmer clean.
- **WATER TEMPERATURE:** Use warm water combined with a gentle dish detergent to clean any removable parts.
- **SOFT SPONGE:** Always use a non-abrasive sponge to prevent scratching any of the strip warmer’s surfaces.
- Do not immerse in water or other liquid.

Maintenance

Monthly Checks

Inspect for Wear

PURPOSE: To regularly check all components for signs of wear, tear, or damage, and replace as necessary.

- Turn off and disconnect the machine from the power source.
- Inspect the plug and cord for any indications of excessive wear, which may encompass discoloration, burn marks, cuts, and tears.
- Check the integrity of electrical cords and plug points. If any issues are detected, consult the “Troubleshooting” section or service provider for recommended actions or replacements.

WARNING: Use only lightbulbs that meet local requirements and are specifically designed for food holding areas. Breakage of light bulbs not specifically coated could result in personal injury and/or food contamination.

To replace lightbulb:

1. Disconnect the power supply and wait until the unit has cooled.
2. Unscrew the lightbulb from the unit and replace it with a new, specially coated incandescent or optional halogen bulb.

PROFESSIONAL SERVICING

Annual Maintenance

PURPOSE: To ensure that specialized features like electrical components and temperature controls are working correctly.

- Schedule an annual service appointment with a certified technician.
- The technician will perform a comprehensive inspection, checking electrical components.
- Any worn-out or damaged parts will be replaced.

Troubleshooting

Issue	Reason	Solution
Unit is turned "ON" but there is no heat.	No power to unit.	Check circuit breaker and reset as necessary.
	Switch is defective.	Contact authorized service agent.
	Wiring is open.	Contact authorized service agent.
	Heating element defective.	Contact authorized service agent.
Heat is inadequate.	Unit mounted too high above target.	Lower unit, putting effective heat closer to target.
	Excessive air movement around strip heater target area.	Restrict or redirect air movement (air conditioning duct or exhaust fan) away from unit.
	Incorrect power supply (low).	Check power supply to unit, making sure it matches rating on the unit. If power supply is incorrect, change to match rating.
Heat is excessive.	Unit mounted too close to target area.	Check to see that installation is within specifications for type/model. Increase mounting height if too close.
	Voltage supply too high.	Check power supply to unit, making sure it matches rating on unit. If power supply is incorrect, change to match rating.
Control switches burn out.	Unit mounted improperly.	Move the unit the proper distance away from the walls, counters, and/or pass-through shelves. Refer to the "Installation" section for guidelines.
	Remote control enclosure is mounted too close to the heat zone.	Move remote control enclosure away from the heat zone.
	Switches used are not proper.	Contact authorized service agent.