

## Avantco SS-UC-48F-HC 48" Undercounter Freezer

Item #178SSUC48FHC



### Technical Data

Width	47 1/4 Inches
Depth	29 1/2 Inches
Height	35 1/4 Inches
Interior Width	42 1/2 Inches
Interior Depth	22 7/8 Inches
Interior Height	23 1/2 Inches
Work Surface Height	35 1/4 Inches
Amps	1.91 Amps
Hertz	60 Hertz
Phase	1 Phase
Voltage	115 Volts
Access Type	Doors
BTU (LBP)	1264
Capacity	11.2 cu. ft.
Compressor Location	Rear Mounted
Compressor Style	Side / Rear Breathing
Door Style	Swing
Door Type	Solid
Hinge Location	Left/Right
Horsepower	1/2 HP
Number of Doors	2 Doors
Number of Shelves	2 Shelves
Plug Type	NEMA 5-15P
Refrigerant Type	R-290
Style	Counter Height
Temperature Range	-8 - -1 Degrees F
Type	Freezers

### Features

- Strong and sleek 430 type stainless steel exterior
- 304 type stainless steel interior maintains temperatures from -8 to -1 degrees Fahrenheit
- Foamed-in-place polyurethane insulation
- Easy-to-read digital temperature controller and auto-defrost function
- 115V; 1/2 hp; 1.91 Amps

### Certifications



5-15P



ETL Sanitation



ETL US

Plan View

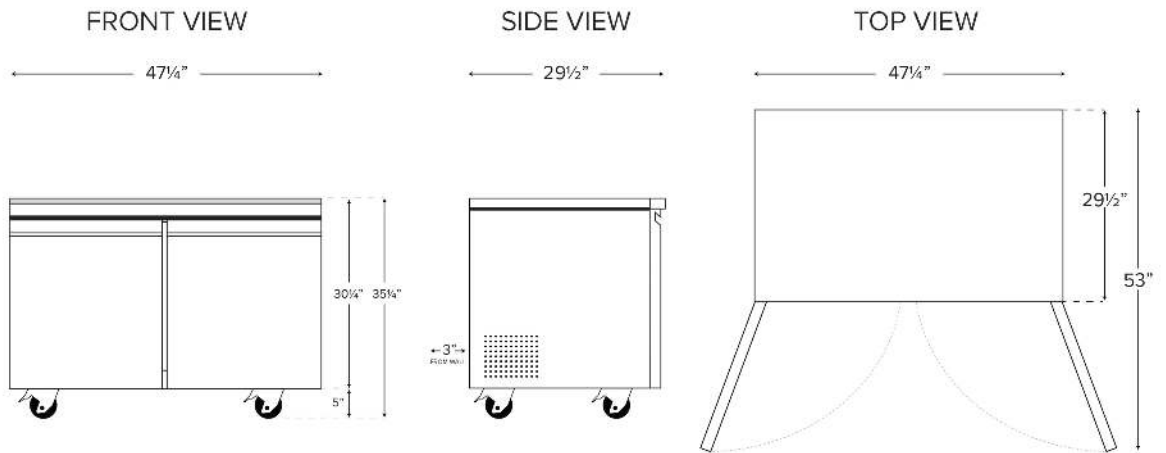
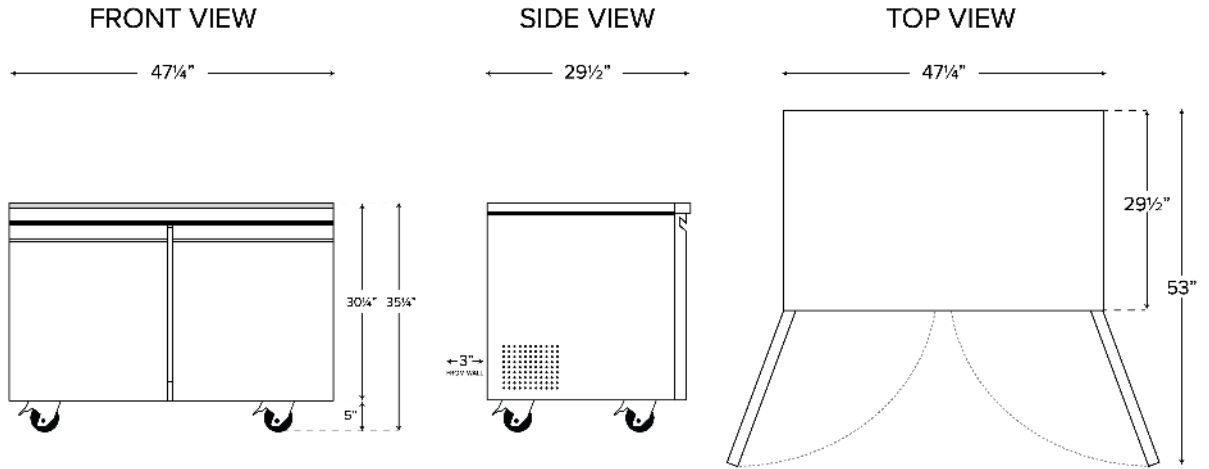



## Notes & Details

Make cold food storage as convenient as possible with the Avantco 48" undercounter refrigerator. With a spacious refrigerated portion readily accessible through its two doors, the unit opens up to two shelves to help you organize your ingredients and best utilize the 11.2 cu. ft. interior. Plus, because they each accommodate up to 90 lb., the epoxy-coated steel shelves are well equipped for holding heavy bulk ingredients, from dozens of eggs to jars of condiments and sauces.

This unit is designed for outstanding durability to ensure that it withstands tough, busy kitchen environments with ease. It features a 430 type stainless steel exterior, which provides both strength and a smooth, sleek appearance. The interior, made with 304 type stainless steel, also offers the durability necessary for heavy, regular use. Because of its undercounter design, the unit effortlessly adds refrigerated storage space without requiring space devoted solely to its footprint.

This refrigerator ensures optimal performance by operating with a 1/2 hp refrigeration system that circulates environmentally-friendly R290 hydrocarbon refrigerant to maintain temperatures from 33 to 40 degrees Fahrenheit. R290 refrigerant has an ozone depletion potential (ODP) of 0 and a global warming potential (GWP) of 3, making it an environmentally-responsible choice for your business. The foamed-in-place polyurethane insulation helps to trap in the cold air and to prevent the ambient air from entering. This ensures that all food held in the unit remains at food safe temperatures and ready for preparation or direct service to customers!

Operation of the refrigerator is easy, thanks to its special features. Monitor it by consulting the interior wall-mounted thermometer, and use the auto-defrost feature on the pre-programmed digital controller to maintain the refrigerator in tip-top shape. 2 1/2" casters make moving simple for easy cleaning and bring the unit to an ADA-compliant working height. This undercounter unit requires a 115V electrical connection for operation.

**⚠ WARNING:** This product can expose you to chemicals including lead, which are known to the State of California to cause cancer, birth defects, or other reproductive harm. For more information, go to [www.p65warnings.ca.gov](http://www.p65warnings.ca.gov).