



Commercial Countertop Griddles, Charbroilers & Ranges



Models: 177CAG15TG, 177CAG24TG, 177CAG36TG, 177CAG48TG,
177CAG60TG, 177CAG15MG, 177CAG24MG, 177CAG36MG,
177CAG48MG, 177CAG60MG, 177CAG24RC, 177CAG36RC,
177CAG48RC, 177CAGR212, 177CAGR424, 177CAGR636

07/2021

Please read and keep these instructions. Indoor use only.

Index

Important Safety Information	3
Installation	5
Clearances	5
Rating Plate	6
Gas Pressure Regulator	7
Gas Conversion Instructions	8
Cleaning	15
Maintenance	16
Technical Specifications	17
Technical Data	19
Parts Diagrams	21
Warranty	29



WARNING

Improper installation, adjustment, alteration, service, or maintenance can cause property damage, injury, or death. Read the installation, operating, and maintenance instructions thoroughly before installing or servicing this equipment.



FOR YOUR SAFETY

DO NOT STORE OR USE GASOLINE OR OTHER FLAMMABLE VAPORS OR LIQUIDS IN THE VICINITY OF THIS OR ANY OTHER APPLIANCE.

NOTE: Save these instructions for future reference

IMPORTANT SAFETY INFORMATION

- Please observe all local and national codes and ordinances.
- Installation must conform with local codes, or in the absence of local codes, the National Fuel Gas Code, ANSI Z223.1 (latest edition). In Canada, installation should conform to installation codes for gas burning appliances and equipment standard CAN/CGA-8149.1 or the propane installation code, CAN/CGA-8149.2, as applicable.
- Installation must be performed according to the manufacturer's instructions and by qualified and authorized persons.
- For repairs, contact an authorized service technician only and request original replacement parts;
- Before operating the product and whenever there is any doubt about its operation, the user has the duty to read and understand this manual in detail.
- Install the equipment in a place where there is sufficient physical space for perfect handling of the equipment.
- Never use your equipment without first installing it correctly.
- If any abnormalities in operation are observed when using the equipment, discontinue use, close the manual gas shut-off valve, and call an authorized service technician to correct the problem.
- Any unauthorized alterations and / or tampering is DANGEROUS and will void all warranties.
- Close the gas valve that powers the equipment and check that the knobs are in the closed position when: not in use, before servicing and cleaning the product.
- Fully assemble all components before turning on the product.
- Use three or more people or a load lifting device to move and install.
- Do not soil, remove, or obstruct the identification labels.
- For proper operation of the appliance, do not obstruct the flow of gas and ventilation.
- When your product is in use, accessible parts can become hot, and children should be kept away.
- Ensure that children do not play with the equipment.
- Always check that the gas connections are correctly installed, and have no malfunctions and no gas leaks.
- Carefully keep this manual for future reference.
- Failure to follow the instructions in the consumer manual for product installation conditions will void your warranty.
- Never use the equipment if it is damaged or not working properly.
- Water or oil may make the floor slippery and dangerous. To avoid accidents, the floor must be dry and clean.

- Do not repair or replace any part of the equipment unless specifically recommended in the manual.
- Clean the product daily after use using neutral detergent. Use abrasive materials only for work surface cleaning.
- Do not use the product to heat the environment.
- Do not use loose hanging garments, towels, or large cloths when using near the product as they may ignite.
- Prevent water, dirt or dust from coming into contact with the equipment's mechanical and gas components;
- Use only kitchen utensils suitable for the product.
- Always use certified hoses and pressure regulators.
- The manufacturer reserves the right to modify, at any time and without prior notice, the contents of this manual.



IMPORTANT

INTENDED FOR INDUSTRIAL/PROFESSIONAL USE ONLY.



WARNING

This device is not intended for use by persons (including children) with reduced physical, sensory or mental capacities, or people with lack of experience and knowledge, unless they have received instructions regarding the use of the device or are under the supervision of a person responsible for their safety.

Periodically check that the hose and gas regulator are within their expiration date; If you constantly smell gas, turn off the product quickly and check if your product gas connections are leaking. If the problem persists, contact your nearest authorized dealer.

Installation

Upon receipt of the equipment, make sure that the product is not defective. For assembly, verify first if the accessory kit has the following items: a gas pressure regulator, an instruction manual, the gas conversion, the gas conversion injectors and a lighter (wick).

Position the product carefully and adjust the foot level.

The gas pressure regulator supplied with the equipment must be installed when the appliance is connected to the gas supply. Installation must comply with local codes or, in the absence of local codes, with the national combustible gas code.

Gas product supply piping must be at least 3/4" in diameter.

Adequate space must be left in front of the device for proper maintenance and operation. Provisions should be incorporated into the kitchen design to ensure an adequate supply of fresh air and adequate clearance for combustion chamber overhead operations, for proper combustion and ventilation.



IMPORTANT

Conversion, gas line connection, thermostat calibration, burners, manometer gas pressure adjustment, etc. are all part of the normal installation and will not be covered under warranty. If a warranty technician is called and the unit is installed incorrectly, the end user may be charged.

Proper installation of this gas appliance is the sole responsibility of the end user. It is the buyer's responsibility to determine if the installer is qualified in the installation procedures.

Clearances

The appliance area must be kept free and clear of all combustibles.

MODEL	COMBUSTIBLE		NON-COMBUSTIBLE	
	REAR	SIDES	REAR	SIDES
Countertop Thermostatic Gas Griddles	8"	6"	0"	0"
Countertop Manual Gas Griddles	8"	6"	0"	0"
Countertop Radiant Gas Charbroilers	8"	6"	0"	0"
Countertop Gas Hot Plates	8"	6"	0"	0"

Rating Plate

Information on this plate includes the model, serial number, BTU/hour input of the burners, operating gas pressure in inches WC, and whether the appliance is orificed for natural or propane gas. When communicating with factory about a unit or requesting special parts or information, rating plate data is essential for proper identification.

Recommendations Before Installation

Before installing the gas supply system, observe the pipes and fittings, check the components for dirt, clean internally with compressed air to eliminate possible particles, and prevent burners and valves from becoming clogged.

After cleaning, use thread sealant to connect the equipment to the gas network. For correct application, avoid concentrating the compound on the first two threads of the pipe, otherwise it may generate particles that will clog the system injectors.

Gas Standards & Codes



IMPORTANT

FAILURE TO INSTALL THE PRESSURE REGULATOR WILL VOID YOUR WARRANTY.

Installation of this appliance must be in accordance with local installation codes, including:

1. The appliance and its individual shutoff valve must be disconnected from the gas supply piping system during any system pressure testing when this teste pressure exceeds 1/2 PSI (3.45 kPa).
2. The appliance shall be isolated from the gas supply piping system by closing the manual shut-off valve during any pressure test of the gas supply piping system at test pressures equal to or less than 1/2 PSI (3.45 kPa).

GAS CONNECTION

The gas inlet line size of this appliance is 3/4" NPT. For proper operation, the gas supply line must be the same size or larger. Gas line size should not be reduced at any point along the supply line.

MANUAL SHUTOFF VALVE

A gas pressure regulator and a shut-off valve supplied by the technician shall be installed in the gas service line before the appliance - in a physical location where it can be reached quickly in an emergency.

Gas Pressure Regulator

The gas pressure regulator (which accompanies the product) is of utmost importance for its operation and is indispensable. The pressure regulator must be installed in the product supply gas line (failure to install the pressure regulator will void the equipment warranty).

Regulators are supplied with 3/4" NPT connection ranges. The regulator is factory set by 102mmH₂O (4" WC) water column gas pressure at connector (natural gas) and gas pressure at 254mmH₂O (10" WC) connector for LPG gas operation.

Before connecting the regulator, check the supply line pressure in the product. This may not exceed the maximum pressure of 3.45kPa (1/2 PSI). If the gas supply line pressure is higher than indicated, use a pressure reducing regulator.

At the bottom of the regulator body there is a gas direction arrow to minimize installation error. This arrow should point to the device's direction of entry into the product.

The blue air vent cap on the top of the regulator is part of the regulator and should not be removed.

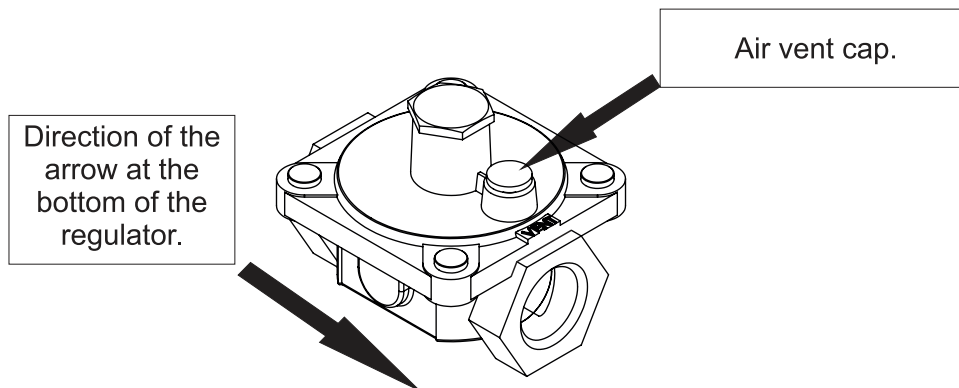

IMPORTANT

Visually check all inlet pipes supplied by the installer and/ or blow them out using compressed air to clean out any dirt or debris (threads or other foreign matter) before installing a service line. These particles will clog the gas holes when gas pressure is applied. Compounds used in appliance pipe threaded joints shall be resistant to the action of GN and LPG gas and shall provide a gas tight seal to prevent leakage.

When installing the pressure regulator remember that it can support 1/2 PSI (3.45kPa).

When installing LPG, you have high source pressures ranging from 20 PSI (127.89kPa) to 100 PSI (689.48 kPa). If the LPG tank's high pressure gas line is directly connected to a unit without the proper reduction regulator, it will rupture the diaphragm in the valve, making it useless.

Any adjustment to the regulator should be done only by qualified and licensed personnel with the appropriate calibrated test equipment.

Connections must be made by a licensed and qualified contractor.

Gas Conversion Instructions

The products are produced for the use of natural gas (NG). Then check if the gas used in your region is compatible with the type of gas for which the product was manufactured. Otherwise, the product must be converted to be used in propane gas (LPG).



IMPORTANT

TO PERFORM GAS CONVERSION, A LICENSED AND QUALIFIED TECHNICIAN IS REQUIRED.

After converting the product gas, the pressure regulator must be converted by inverting the fitting under the regulator cover. This will require a reasonable amount of force. Do not remove the spring. When replacing the cover, make sure the insert of the socket is facing upwards in the middle of the spring. As shown in the image on the side.

Then re-attach the pressure regulator to the gas inlet of the product and apply the "Warning" sticker for the gas to be used on the front of the unit for future reference.

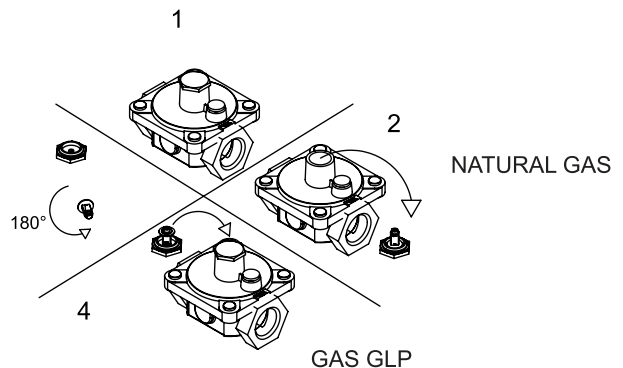

COUNTERTOP THERMOSTATIC GAS GRIDDLE

For conversion the following guidelines should be followed:

1. Close the manual gas valve and disconnect the product from the gas network, making sure that there is no leakage. Then remove the pressure regulator from the gas inlet on the product to make work easier.
2. Remove the manual gas griddle assembly (1) with the help of two or more people. For this, extreme care must be taken, as physical injuries or serious damage can occur.
3. Carefully pull the wire from the thermostat bulb that is fixed inside a support welded on the bottom of the plate until it is loose.
4. Remove the screws that secure the burners (3) to the rear support and pilot burner support (6) with the aid of the double screwdriver. Afterwards, remove the burners from the product.
5. Remove the burners injectors (4) with a 1/2" wrench.

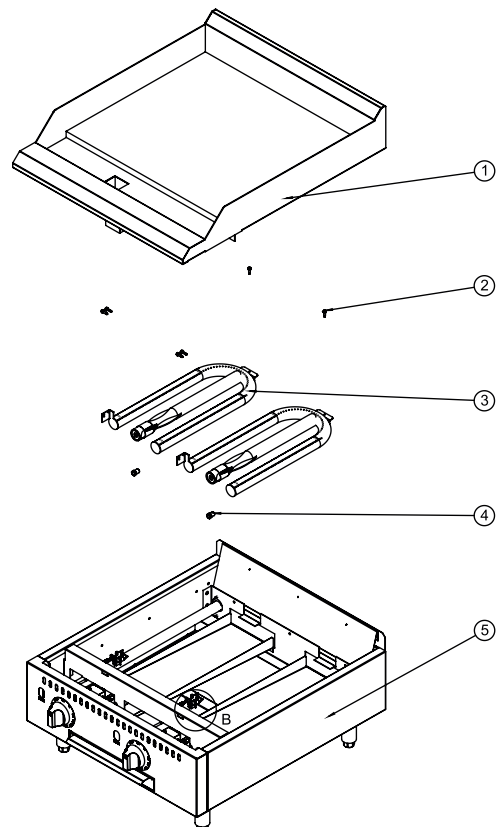
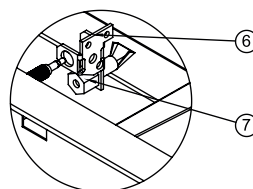

6. In place of the removed gas injectors (4), place the new injectors that are included with the kit shipped with the product. But first apply some pipe sealant to the valve thread and then screw-in the new injectors to the correct gas type.
7. Remove the pilot burner nut (7) to change the injector orifice that is inside the nut. The orifice for the exchange is included in the accessory kit.
8. After changing the gas injectors, reassemble your product. Return the burners to their original configuration, however, now with the new injectors.
9. After repositioning the thermostat bulb inside the welded support at the bottom of the plate, fit the plate assembly back into the product. Replace the panel and secure it with the screws that were removed earlier.
10. The following image serves to help identify the components mentioned above.

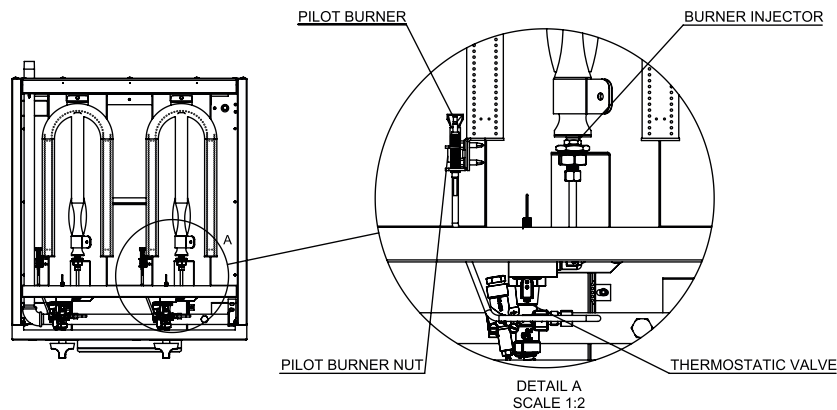

COUNTERTOP MANUAL GAS GRIDDLE

For conversion the following guidelines should be followed:

1. Close the manual gas valve and disconnect the product from the gas network, making sure that there is no leakage. Then remove the pressure regulator from the gas inlet on the product to make work easier.
2. Remove the manual gas griddle assembly (1) with the help of two or more people. For this, extreme care must be taken, as physical injuries or serious damage can occur.
3. Remove the screws that secure the burners (2) to the rear support with the aid of the double screwdriver. Afterwards, remove the burners from the product.
4. Remove the injectors (3) with a 1/2" wrench.
5. In place of the removed gas injectors (3), place the new injectors that are included with the kit shipped with the product. But first apply some pipe sealant to the valve thread and then screw-in the new injectors to the correct gas type.
6. Once the gas injectors (3) are changed, reassemble your product (4).

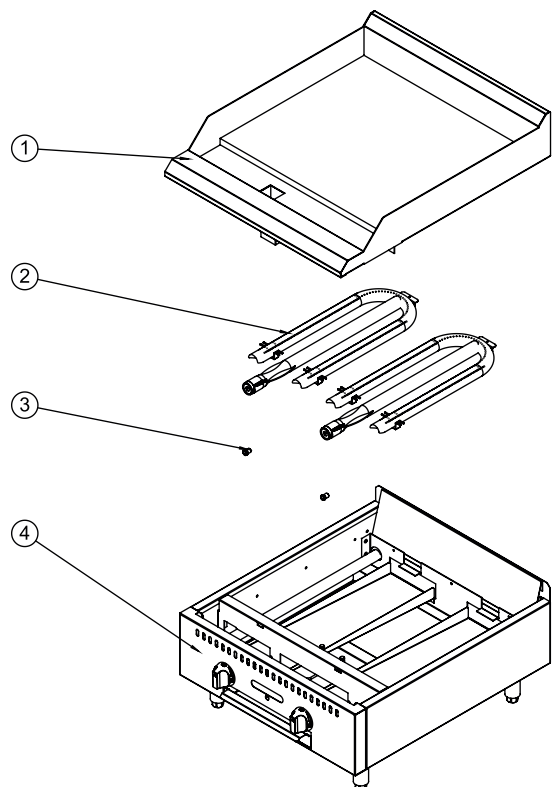

COUNTERTOP RADIANT GAS CHARBROILER

For conversion the following guidelines should be followed:

1. Close the manual gas valve and disconnect the product from the gas network, making sure that there is no leakage. Then remove the pressure regulator from the gas inlet on the product to make work easier.
2. Remove the waste drawer (1), knobs (2) from the product and then remove the panel (3) by removing the two screws located at the bottom of the panel with the aid of a double screwdriver and detaching the upper panel fittings on the product.
3. Remove the removable grilles (9), the deflectors (8) and the welded structure set (7). For this, extreme care must be taken, as physical injuries or serious damage can occur.
4. To remove the distributor tube assembly, remove the screws that secure the distributor tube assembly (4) to the front support with the aid of a double screwdriver.
5. Remove the injectors (5) with a 1/2" wrench.
6. In place of the removed gas injectors (3), place the new injectors that are included with the kit shipped with the product. But first apply some pipe sealant to the valve thread and then screw-in the new injectors to the correct gas type.
7. Once the gas injectors are changed, reassemble your product (6).

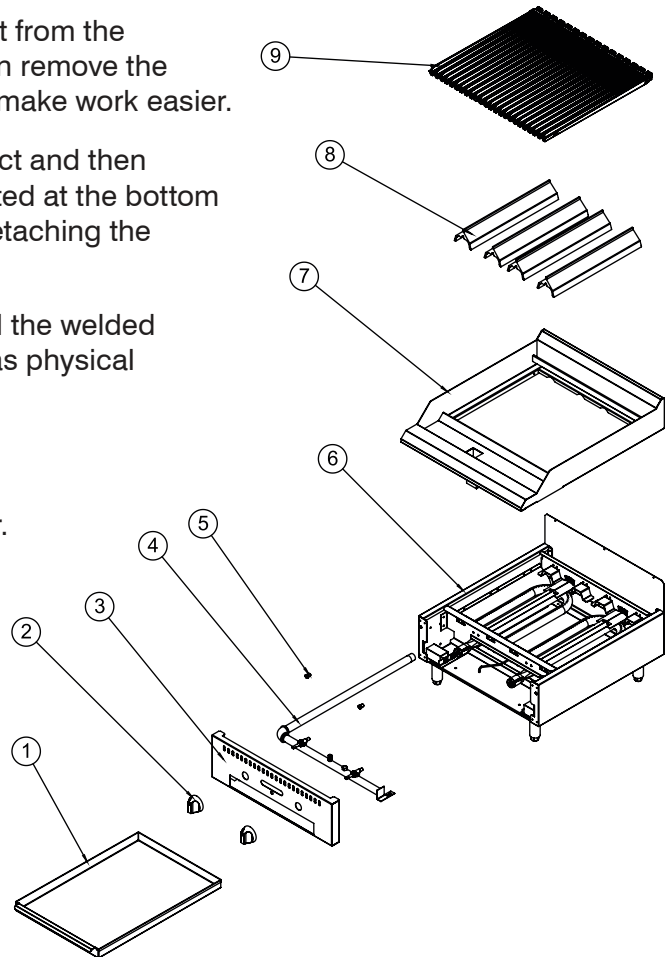

COUNTERTOP GAS HOT PLATE

For conversion the following guidelines should be followed:

1. Close the manual gas valve and disconnect the product from the gas network, making sure that there is no leakage. Then remove the pressure regulator from the gas inlet on the product to make work easier.
2. Remove grills (1) and burners (2).
3. Remove the injectors (3) with a 1/2" wrench.
4. In place of the removed gas injectors (3), place the new injectors that are included with the kit shipped with the product. But first apply some pipe sealant to the valve thread and then screw-in the new injectors to the correct gas type.
5. Once the gas injectors (3) are changed, reassemble your product (4).

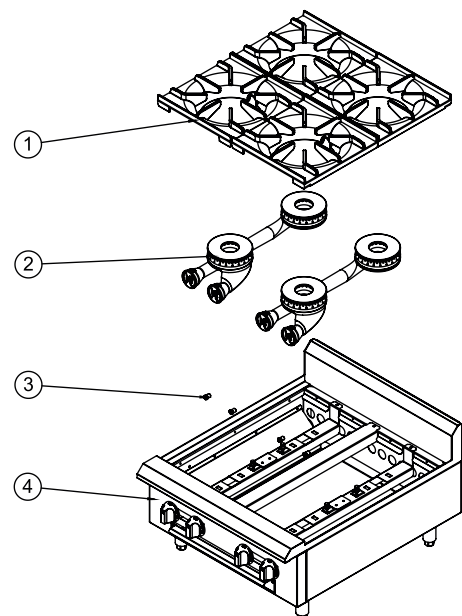

LPG Gas Installation at Low Pressure

To use the product with LPG gas at low pressure, it is necessary that the product is checked with the injector for use of LPG gas, if it is not with the appropriate injector, the gas conversion should be performed following the steps described in item 2.5 of this manual.

The installation of low pressure LPG gas must be carried out in a gas station distant from the equipment used.

A first stage (first) regulating valve with an inlet of 7 kgf/cm² and an outlet pressure of 1.2 kgf/cm² is installed on site, placing copper or carbon steel piping as a gas conductor to the equipment seamless. Install at the end, next to the equipment a second 2^o (second) stage valve with inlet pressure of 1.2 kgf /cm² and outlet pressure of 2.8 kPa or 280mmc.a.H₂O.

Using a certified hose, connect the valve directly to the pressure regulator at the gas inlet at the rear of the product, securing both ends with clamps to both the 2nd stage valve and the equipment.

Note: If in doubt consult the legislation in force in your state/ municipality.



IMPORTANT

Keep cylinders always upright (standing) and never horizontal (lying down).

Gas Leak Check

Before lighting the equipment and putting it into operation, check all gaskets on the gas supply line for leaks. For this, do not use any type of wrench to check for leaks, use a sudsy soap and water solution.

Follow the steps below for the correct procedure to power on:

1. Turn pilot valves to OFF position by turning adjusting screws clockwise.
2. Turn on the manual gas valve on the inlet side of the gas supply line.
3. Check for gas leaks at the flexible coupling or gas connector connection using a soap solution.
4. In moderation, spray or scrub the solution with soap on gas connections - active bubbling indicates the location of the gas leak.
5. If a gas leak is detected, turn off the manual gas valve at the inlet side of the gas line. Call your certified and licensed service technician.
6. If the equipment has no gas leak, continue with the equipment operating instruction.

First-Time Use

Against shock damage or rocking from transportation, the sides and waste tray have a protective PVC film. Remove any plastics, straps, or protective film from the product before operating the equipment.

COUNTERTOP GAS GRIDDLE, THERMOSTATIC & MANUAL

To protect the equipment against possible moisture damage between fabrication and installation on site, the flat-tops are coated with a layer of vegetable shortening and brown paper.

In addition, you should remove grease and brown paper, cleaning should be performed with the aid of a sponge, mild soap and water in small amount.

After this procedure, turn the burners on and leave them on for about 15 minutes, this will cause all flat-top grill residue to be burned and eliminated. Only then will the equipment be ready for use.

COUNTERTOP GAS RADIANT CHAR BROILER

To protect the equipment against possible moisture damage between manufacture and installation on site, the grills and baffle rails are coated with a layer of vegetable oil.

In addition, you should perform a cleaning with the help of a sponge, neutral soap and water in small amounts. After this procedure, turn the burners on and leave them on for about 15 minutes, this will cause all gas charbroiler residue to be burned and eliminated.

Only then will the equipment be ready for use.

COUNTERTOP GAS RANGE

You should perform a cleaning with the help of a sponge, neutral soap and water in small amounts. Only then will the equipment be ready for use.

Product Ignition

If you need to adjust the pilot valves (one pilot valve corresponds to two burners) do the following:

1. Turn the pilot adjusting screw counterclockwise, then light the pilot with the aid of the igniter (wick) accompanying the product and adjust the flame to a height of approximately 0.5 cm;
2. Turn on the gas valve by turning the knob counterclockwise to light the main burners;
3. To shut down completely, close the gas valves by turning the knob clockwise and turn the pilot adjusting screw clockwise to close the gas for the pilots.

Pilot screw adjustment

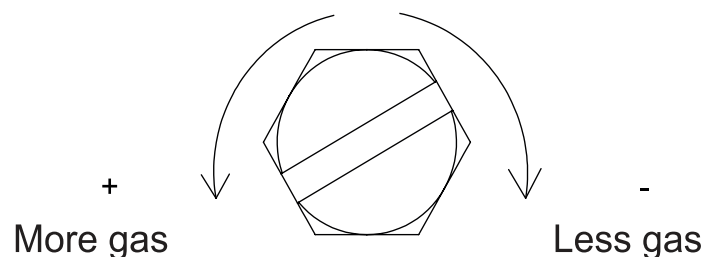

COUNTERTOP GAS GRIDDLE, THERMOSTATIC

1. Open the manual gas supply valve (which will release gas into the product);
2. Immerse in alcohol the lighter (wick) that accompanies the product and light it; Note: Make sure that the container where the alcohol is located is away from the product and wick after immersing.
3. Press lightly and rotate the handle to the pilot position.
4. Keep it pressed and take the igniter (wick) passing between the pilot flame ignition hole in the product panel until it comes into contact with the pilot and ignites the flame;
5. Keep the knob pressed for 10 seconds after the pilot flame is lit and turn the knob counterclockwise until the wished temperature (use the knob to adjust the temperature);
6. Make sure the burner is lit. If the burner does not light, repeat the procedure;

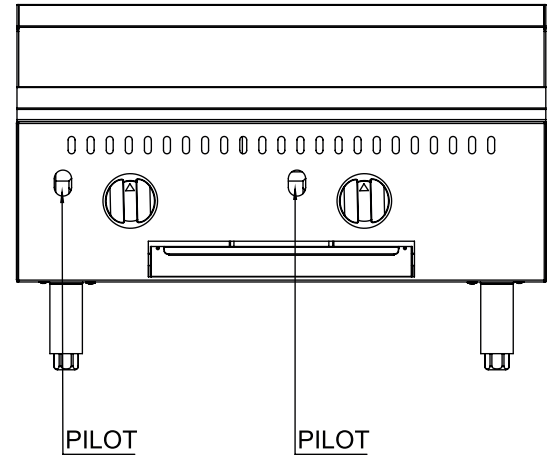

COUNTERTOP GAS GRIDDLE, MANUAL

1. Open the manual gas supply valve (which will release gas into the product).
2. Immerse in alcohol the lighter (wick) that accompanies the product and light it; Note: Make sure that the container where the alcohol is located is away from the product and wick after immersing;
3. Take the igniter (bypass) past the ignition hole in the flame of the pilot on the product panel until contact with the pilot burner and until the flame ignites, repeat this procedure on all pilots (see following image); Note: The ignition order does not interfere with the use of the equipment;
4. Turn the knob corresponding to the burner you wish to operate counterclockwise (adjust the flame through the knob);
5. Make sure the burner is lit. If the burner does not light, repeat the procedure;
6. After lighting all burners, you can turn off the burners and turn them back on simply by turning the corresponding knobs; Note: The pilot burner flame is factory set according to the gas for which the product was originally manufactured. Always check through the hole identified on the panel as PILOT, if the pilot burner flame is lit. If it is not, perform the procedures described above again.

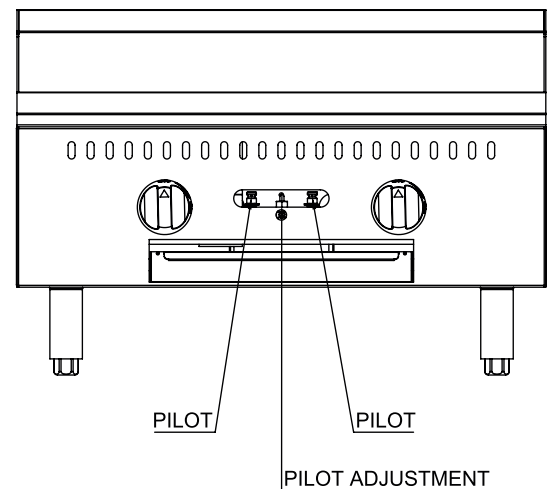

User Manual

COUNTERTOP RADIANT GAS CHARBROILER

1. Open the manual gas supply valve (which will release gas into the product);
2. Immerse in alcohol the lighter (wick) that accompanies the product and light it; Note: Make sure that the container where the alcohol is located is away from the product and wick after immersing;
3. Bring the igniter (wick) through the pilot flame ignition hole in the product panel until contact with the pilot burner and until the flame ignites, repeat this procedure on all pilots (see the following image);
4. Rotate the knob corresponding to the burner you wish to operate, rotate 90° counterclockwise;
5. Make sure the burner is lit. If the burner does not light, repeat the procedure;
6. After lighting all burners, you can turn off the burners and turn them back on simply by turning the corresponding knobs; Note: The pilot burner flame is factory set according to the gas for which the product was originally manufactured. Always check to see if the flame on the pilot burner can be seen through the panel hole. If it is not lit, perform the procedures described above again.

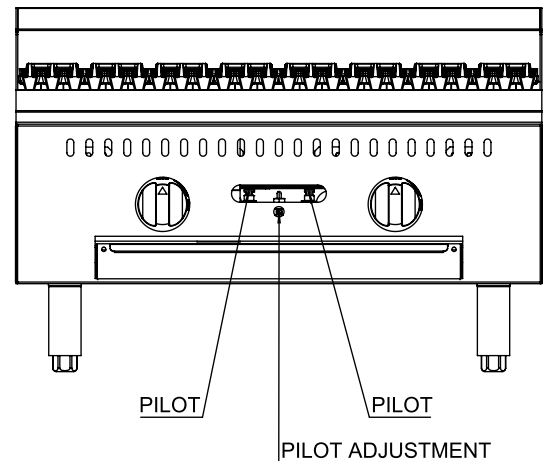

COUNTERTOP GAS HOT PLATE

1. Open the manual gas supply valve (which will release gas into the product);
2. Immerse in alcohol the lighter (wick) that accompanies the product and light it; Note: Make sure that the container where the alcohol is located is away from the product and wick after immersing.
3. Bring the igniter (wick) until contact with the pilot burner until the flame ignites, repeat on all others. (see image); Note: The ignition order does not interfere with the use of the equipment;
4. Turn the knob (BUTTON) corresponding to the burner you wish to operate counterclockwise (adjust the flame through the knob);
5. Make sure the burner is lit. If the burner does not light, repeat the procedure; Note: The pilot burner flame is factory set according to the gas for which the product was originally manufactured. Always check that the pilot burner flame is lit. If it is not, perform the procedures described above again.

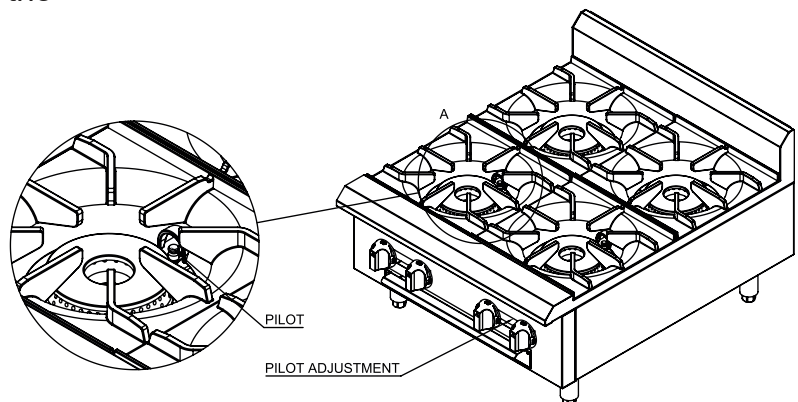

Cleaning



IMPORTANT

Do not use toxic or high chemical cleaning materials. See all instructions given by the cleaning product manufacturer.

After using the product and with the equipment not working or hot, clean it to remove food residue. Remove the waste drawer for debris removal and cleaning.

- Use a non-abrasive sponge with mild detergent and water to clean the equipment.
- Never use sharp or abrasive materials (with corrosive elements in the formula) on stainless steel components, but on range and charbroiler grills it is possible. On the Manual Griddle and Thermostatic Griddle flat-top it is recommended to use a kitchen spatula to facilitate the cleaning of residues.
- Keep in mind that constant and correct cleaning is critical to the proper functioning of the equipment.
- NEVER attempt to move or slide the product when it is hot. ALWAYS let the unit cool down and empty the waste drawer before attempting to relocate or move the unit.
- DO NOT FLOOD A HOT GRIDDLE WITH COLD WATER. This could cause warping and the griddle plate to crack.
- After the end of the working day, clean the Gas Range, Charbroiler, and burners and turn them on to remove moisture. On the Manual Griddle and Thermostatic Griddle clean the equipment and grease the flat-top with vegetable oil. This practice is recommended between one working day and another, thus avoiding its oxidation.

Cleaning the Outside of the Product

The product has stainless steel external coating and for its correct cleaning it is necessary to follow the following guidelines:

- First, let the product cool. Normal daily dirt can be removed with a mild detergent or soap solution applied with a damp cloth. Wash and dry thoroughly.
- To remove deposited grease, apply a cleanser in the direction of the polished lines on the metal. NEVER rub in a circular motion.

Cleaning the Inside of the Product

Let the inside of the product cool completely. Use a non-alkaline cleaning agent following the manufacturer's recommendations:

- Do not use abrasive products.
- Rinse well with water at room temperature, clean and dry thoroughly.

Maintenance

Maintenance is one of the precautions to be taken for a good equipment life. Proper cleaning, installation, checking and product life all contribute to reduced maintenance. Before any maintenance, verify that the gas connections, regulators or check valves must be completely closed and disconnected from the product.



IMPORTANT

The maintenance of the equipment should only be performed by a technician authorized by the manufacturer.

The operator should be familiar with how to connect and disconnect the restrictions/removable parts. If the restriction is removed for maintenance or cleaning, it must be reconnected before using the equipment again.

Technical Specifications

COUNTERTOP GAS GRIDDLE, THERMOSTATIC

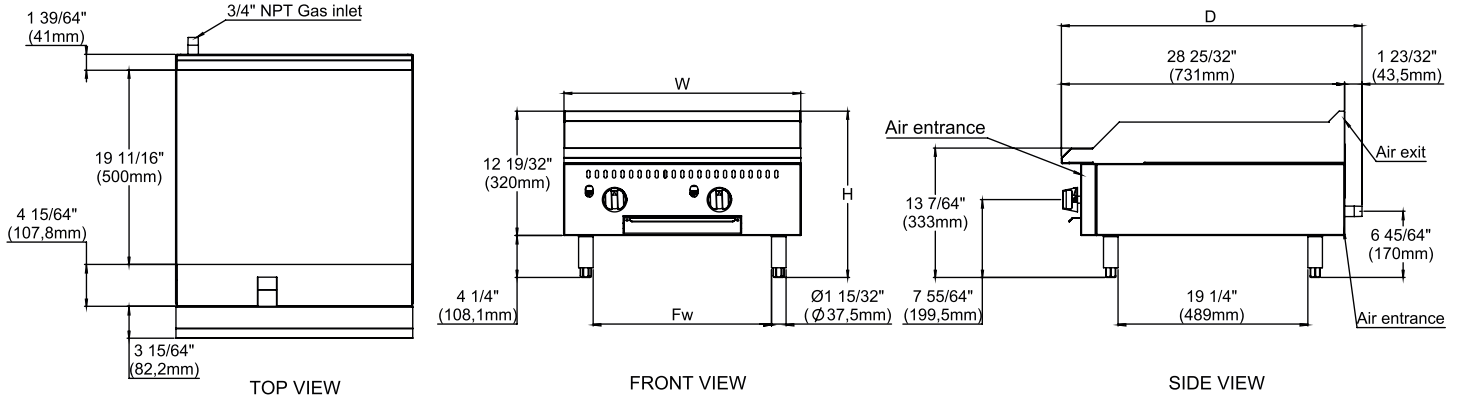

MODEL #	Exterior Product Dimensions & Weight					Shipping Crate Dimensions & Weight			
	WIDTH	DEPTH	HEIGHT	FW	WEIGHT	WIDTH	DEPTH	HEIGHT	WEIGHT
177CAG15TG	15"	30 1/2"	16 7/8"	9 5/64"	110 lb.	19 9/64"	34 9/64"	18 1/2"	150 lb.
177CAG24TG	24"	30 1/2"	16 7/8"	18 3/32"	165 lb.	28 1/16"	34 9/64"	18 1/2"	212 lb.
177CAG36TG	36"	30 1/2"	16 7/8"	31 9/32"	238 lb.	40 1/32"	34 9/64"	18 1/2"	300 lb.
177CAG48TG	48"	30 1/2"	16 7/8"	43 9/32"	313 lb.	52 1/16"	34 9/64"	18 1/2"	386 lb.
177CAG60TG	60"	30 1/2"	16 7/8"	(x2) 26 5/16"	384 lb.	64 1/16"	34 9/64"	18 1/2"	459 lb.

COUNTERTOP GAS GRIDDLE, MANUAL

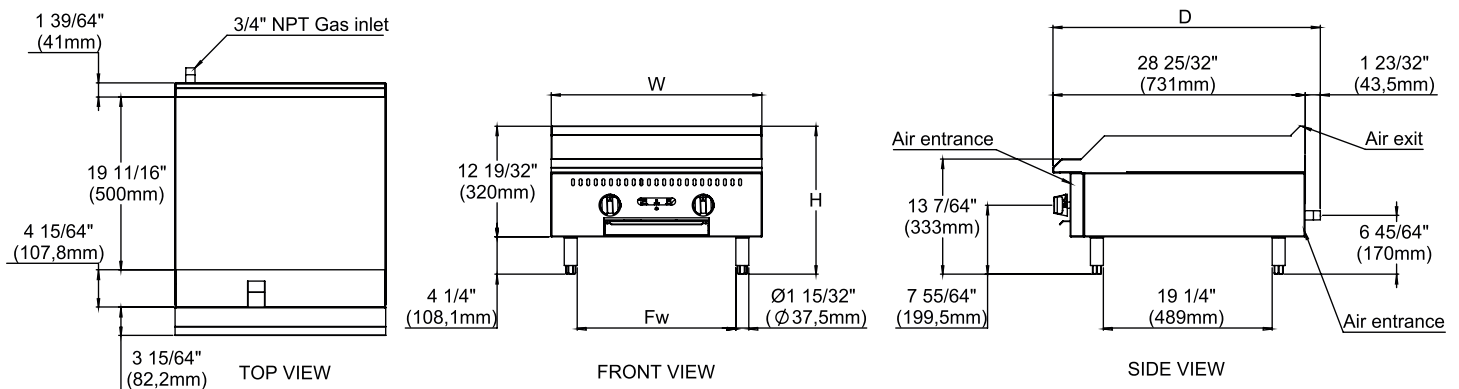

MODEL #	Exterior Product Dimensions & Weight					Shipping Crate Dimensions & Weight			
	WIDTH	DEPTH	HEIGHT	FW	WEIGHT	WIDTH	DEPTH	HEIGHT	WEIGHT
177CAG15MG	15"	30 1/2"	16 7/8"	9 5/64"	110 lb.	19 9/64"	34 9/64"	18 1/2"	148 lb.
177CAG24MG	24"	30 1/2"	16 7/8"	18 3/32"	165 lb.	28 1/16"	35 5/64"	18 1/2"	210 lb.
177CAG36MG	36"	30 1/2"	16 7/8"	31 9/32"	240 lb.	40 1/32"	36 9/64"	18 1/2"	298 lb.
177CAG48MG	48"	30 1/2"	16 7/8"	43 9/32"	315 lb.	52 1/16"	37 9/64"	18 1/2"	381 lb.
177CAG60MG	60"	30 1/2"	16 7/8"	(x2) 26 5/16"	390 lb.	64 1/16"	38 9/64"	18 1/2"	452 lb.

User Manual

COUNTERTOP RADIANT GAS CHARBROILER

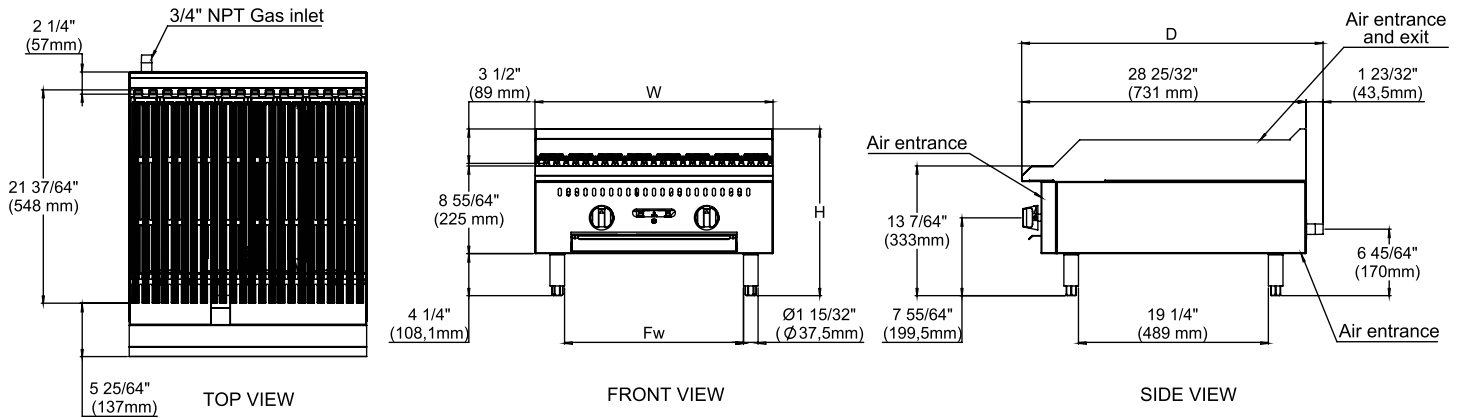

MODEL #	Exterior Product Dimensions & Weight					Shipping Crate Dimensions & Weight			
	WIDTH	DEPTH	HEIGHT	FW	WEIGHT	WIDTH	DEPTH	HEIGHT	WEIGHT
177CAG24RC	24"	30 1/2"	16 7/8"	18"	99 lb.	28 1/8"	34 1/8"	18 1/2"	143 lb.
177CAG36RC	36"	30 1/2"	16 7/8"	31"	172 lb.	40 1/8"	34 1/8"	18 1/2"	220 lb.
177CAG48RC	48"	30 1/2"	16 7/8"	43"	245 lb.	52 1/8"	34 1/8"	18 1/2"	286 lb.

COUNTERTOP GAS HOT PLATE

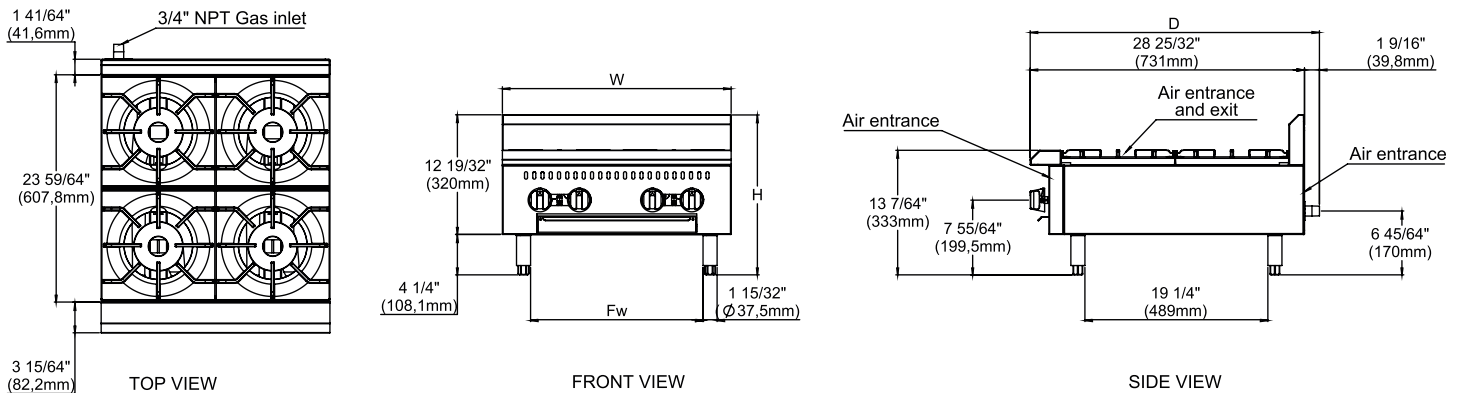

MODEL #	Exterior Product Dimensions & Weight					Shipping Crate Dimensions & Weight			
	WIDTH	DEPTH	HEIGHT	FW	WEIGHT	WIDTH	DEPTH	HEIGHT	WEIGHT
177CAGR212	12"	30 1/2"	16 7/8"	9"	70 lb.	16 1/8"	34"	18 1/2"	110 lb.
177CAGR424	24"	30 1/2"	16 7/8"	18"	121 lb.	28 1/8"	34"	18 1/2"	167 lb.
177CAGR636	36"	30 1/2"	16 7/8"	43 1/5"	174 lb.	40 1/8"	34"	18 1/2"	238 lb.

Technical Data

COUNTERTOP GAS GRIDDLE, THERMOSTATIC

MODEL #	BURNERS	Gas Supply				Manifold Pressure
		GAS TYPE	NOZZLE	BTU/HR	KCAL/HR	TUBE PRESSURE (in. W.C.)
177CAG15TG	1	NAT. GAS	#43	35,000	8,820	4
		L.P. GAS	#54	35,000	8,820	10
177CAG24TG	2	NAT. GAS	#43	70,000	17,640	4
		L.P. GAS	#54	70,000	17,640	10
177CAG36TG	3	NAT. GAS	#43	105,000	26,460	4
		L.P. GAS	#54	105,000	26,460	10
177CAG48TG	4	NAT. GAS	#43	140,000	35,280	4
		L.P. GAS	#54	140,000	35,280	10
177CAG60TG	5	NAT. GAS	#43	175,000	44,100	4
		L.P. GAS	#54	175,000	44,100	10

COUNTERTOP GAS GRIDDLE, MANUAL

MODEL #	BURNERS	Gas Supply				Manifold Pressure
		GAS TYPE	NOZZLE	BTU/HR	KCAL/HR	TUBE PRESSURE (in. W.C.)
177CAG15MG	1	NAT. GAS	#44	30,000	7,560	4
		L.P. GAS	#54	30,000	7,560	10
177CAG24MG	2	NAT. GAS	#44	60,000	15,121	4
		L.P. GAS	#54	60,000	15,121	10
177CAG36MG	3	NAT. GAS	#44	90,000	22,680	4
		L.P. GAS	#54	90,000	22,680	10
177CAG48MG	4	NAT. GAS	#44	120,000	30,240	4
		L.P. GAS	#54	120,000	30,240	10
177CAG60MG	5	NAT. GAS	#44	150,000	37,800	4
		L.P. GAS	#54	150,000	37,800	10

Technical Data

COUNTERTOP RADIANT GAS CHARBROILER

MODEL #	BURNERS	Gas Supply				Manifold Pressure
		GAS TYPE	NOZZLE	BTU/HR	KCAL/HR	TUBE PRESSURE (in. W.C.)
177CAG24RC	2	NAT. GAS	#40	60,000	15,129	4
		L.P. GAS	#52	60,000	15,129	10
177CAG36RC	3	NAT. GAS	#40	90,000	22,694	4
		L.P. GAS	#52	90,000	22,694	10
177CAG48RC	4	NAT. GAS	#40	120,000	30,259	4
		L.P. GAS	#52	120,000	30,259	10

COUNTERTOP GAS RANGE

MODEL #	BURNERS	Gas Supply				Manifold Pressure
		GAS TYPE	NOZZLE	BTU/HR	KCAL/HR	TUBE PRESSURE (in. W.C.)
177CAGR212	2	NAT. GAS	#40	50,000	12,600	4
		L.P. GAS	#53	50,000	12,600	10
177CAGR424	4	NAT. GAS	#40	100,000	25,200	4
		L.P. GAS	#53	100,000	25,200	10
177CAGR636	6	NAT. GAS	#40	150,000	50,400	4
		L.P. GAS	#53	150,000	50,400	10

PARTS DIAGRAM

COUNTERTOP GAS GRIDDLE, THERMOSTATIC

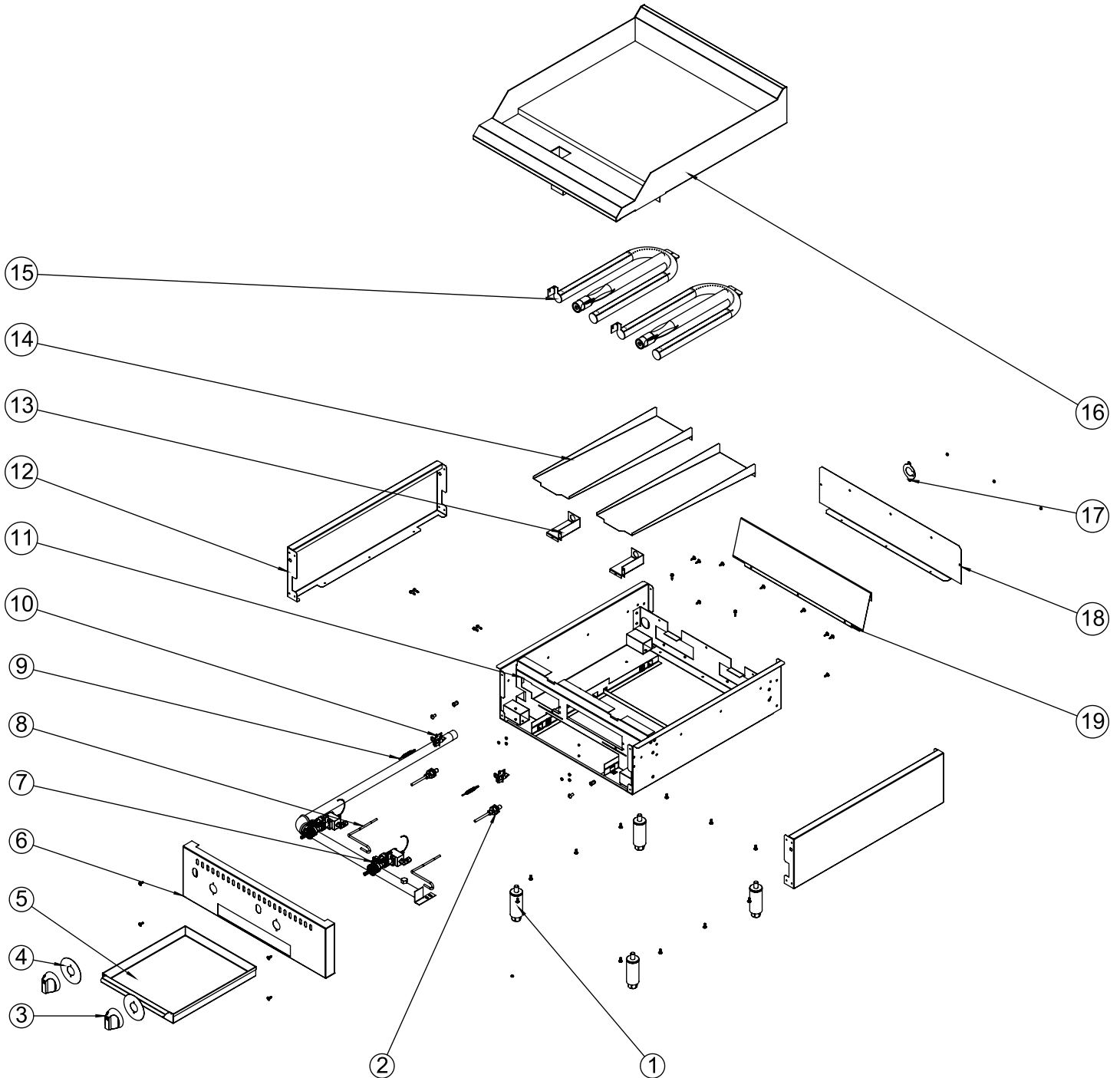

PARTS LIST

COUNTERTOP GAS GRIDDLE, THERMOSTATIC

#	PART #	DESCRIPTION	PART QUANTITY BY MODEL (SIZE)				
			15"	24"	36"	48"	60"
1	8.09.03.00000400	LEG ASSEMBLY	4	4	4	4	6
2	8.01.53.00002000	GAS VALVE ASSEMBLY	1	2	3	4	5
3	8.01.53.00001900	KNOB ASSEMBLY	1	2	3	4	5
4	8.01.53.00000060	KNOB BEZEL	1	2	3	4	5
5	---	GREASE TRAP	1	1	1	1	2
6	8.01.53.00000045	FRONT PANEL	1	1	1	1	1
7	8.01.53.00002300	GAS DISTRIBUTION TUBE ASSEMBLY	1	1	1	1	1
8	8.20.55.42425362	STAINLESS STEEL FLEX TUBE 3/16"	1	2	3	4	5
9	---	THERMOCOUPLE	1	2	3	4	5
10	---	PILOT	1	2	3	4	5
11	8.01.53.00002600	INTERNAL FRAME ASSEMBLY	1	1	1	1	1
12	8.01.52.00000788	EXTERNAL SIDE PANEL	2	2	2	2	2
13	8.01.53.00000046	ORIFICE ASSEMBLY SUPPORT BRACKET	1	2	3	4	5
14	8.01.52.00000785	BURNER DEFLECTOR	1	2	3	4	5
15	8.01.53.00002100	BURNER ASSEMBLY	1	2	3	4	5
16	8.01.53.00002500	GRIDDLE PLATE ASSEMBLY	1	1	1	1	1
17	8.01.52.00000632	GAS TUBE BACK BRACKET	1	1	1	1	1
18	8.01.52.00000786	EXTERNAL BACK PANEL	1	1	1	1	1
19	8.01.52.00000787	INTERNAL BACK PANEL	1	1	1	1	1

GREASE TRAP CODES

Model 15" 8.01.53.00000075

Model 24" 8.01.52.00000781

Model 36" 8.01.53.00000080

Model 48" 8.01.53.00000094

Model 60" 8.01.52.00000781 and 8.01.53.00000080

PARTS DIAGRAM

COUNTERTOP GAS GRIDDLE, MANUAL

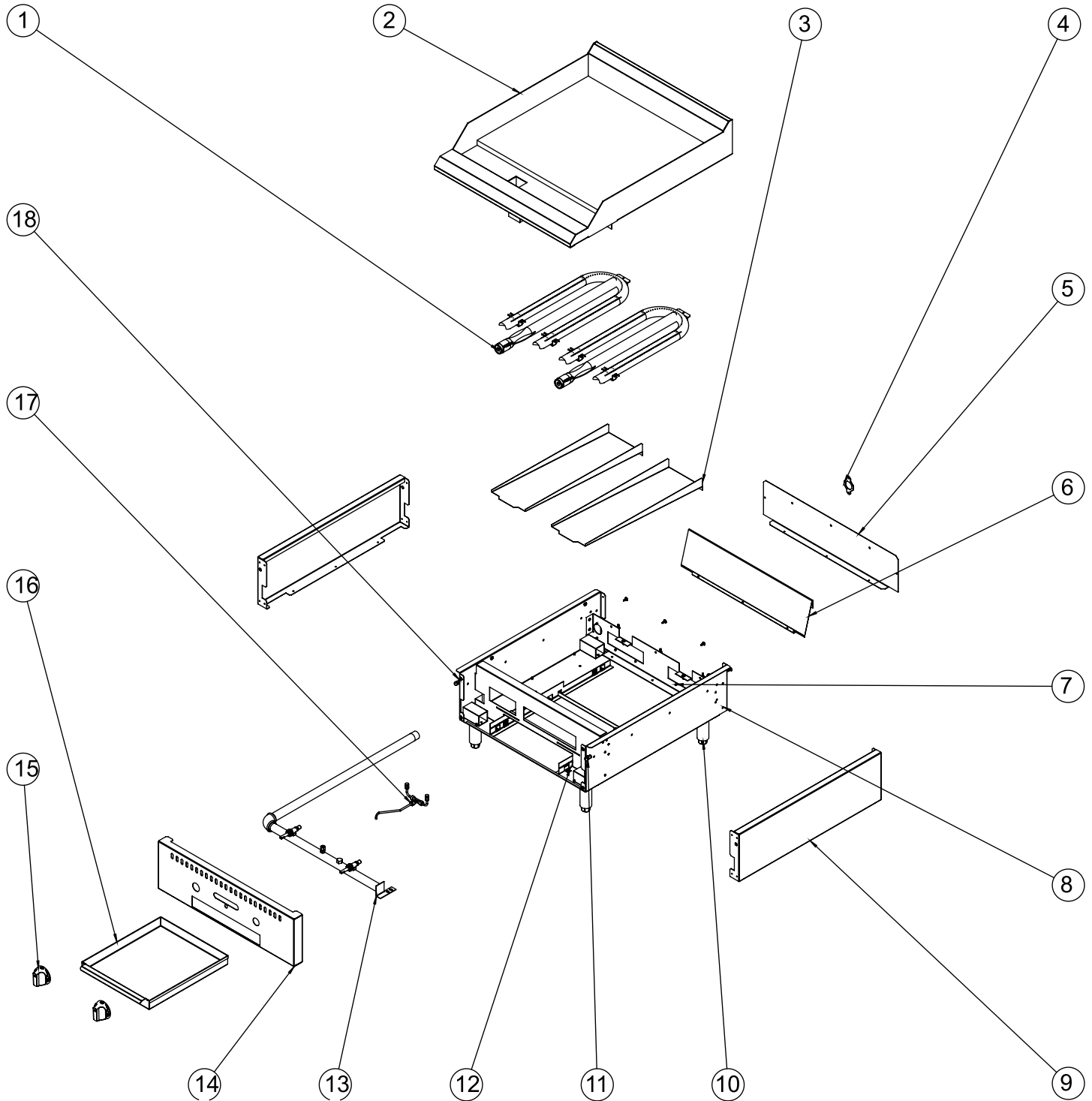

User Manual

PARTS LIST

COUNTERTOP GAS GRIDDLE, MANUAL

#	PART #	DESCRIPTION	PART QUANTITY BY MODEL (SIZE)				
			15"	24"	36"	48"	60"
1	8.01.53.00009500	BURNER ASSEMBLY	1	2	3	4	5
2	8.01.52.00072100	GRIDDLE PLATE ASSEMBLY	1	1	1	1	1
3	8.01.52.00000785	BURNER DEFLECTOR	1	2	3	4	4
4	8.01.53.00000042	GAS TUBE BACK BRACKET	1	1	1	1	1
5	8.01.52.00000786	EXTERNAL BACK PANEL	1	1	1	1	1
6	8.01.52.00000787	INTERNAL BACK PANEL	1	1	1	1	1
7	---	STAINLESS STEEL 4.5 X 10 NT OPEN RPX RIVET	3	7	11	13	10
8	---	STAINLESS STEEL SCREW 4.2 X 13 NT	27	32	35	35	45
9	8.01.52.00000788	EXTERNAL SIDE PANEL	2	2	2	2	2
10	8.09.03.00000400	LEG ASSEMBLY	4	4	4	4	6
11	---	RED FS UNC 1.4-20F X 1.2 ZB SCREW	2	2	2	2	2
12	---	INTERNAL FRAME ASSEMBLY	1	1	1	1	1
13	8.01.52.00072600	GAS DISTRIBUTION TUBE ASSEMBLY	1	1	1	1	1
14	8.01.52.00000780	FRONT PANEL	1	1	1	1	1
15	8.01.53.00001900	KNOB ASSEMBLY	1	2	3	4	5
16	---	GREASE TRAP	1	1	1	1	2
17	8.01.52.00072500	PILOT TUBE ASSEMBLY	--	1	1	2	2
18	---	THREDEAD RIVET	2	2	2	2	2

GREASE TRAP CODES

Model 15" 8.01.53.00000075

Model 24" 8.01.52.00000781

Model 36" 8.01.53.00000080

Model 48" 8.01.53.00000094

Model 60" 8.01.52.00000781 and 8.01.53.00000080

PARTS DIAGRAM

COUNTERTOP RADIANT GAS CHARBROILER

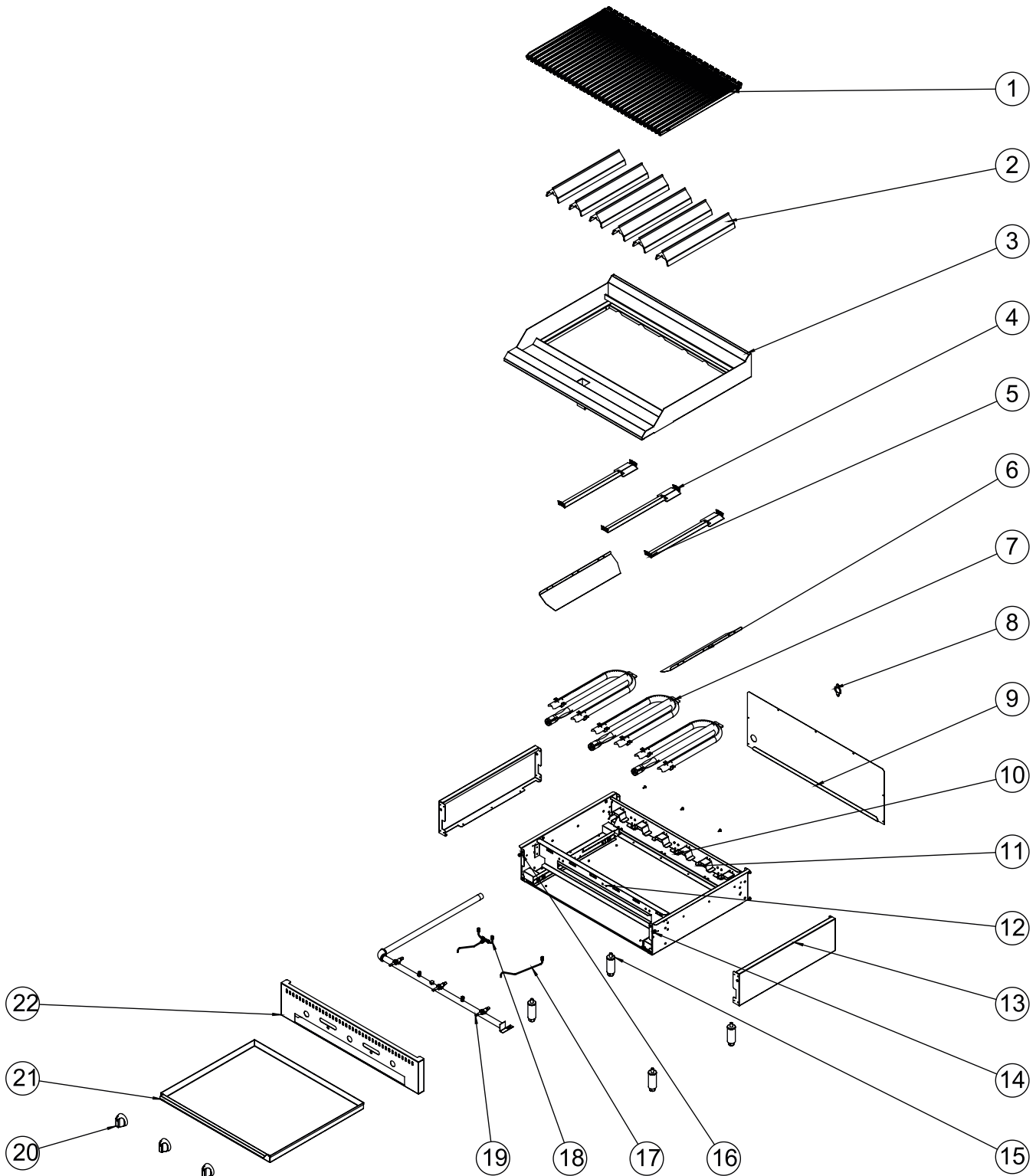

User Manual

PARTS LIST

COUNTERTOP RADIANT GAS CHARBROILER

#	PART #	DESCRIPTION	PART QUANTITY BY MODEL (SIZE)		
			24"	36"	48"
1	8.01.25.00000105	TOP GRATE	8	12	16
2	8.01.53.00000063	RADIANT	4	6	8
3	8.01.53.00004600	EXTERNAL FRAME ASSEMBLY	1	1	1
4	8.01.53.00000065	SMALL BURNER PROTECTION DEFLECTOR	2	3	4
5	8.01.53.00000064	LARGE BURNER PROTECTION DEFLECTOR	2	5	4
6	8.01.52.00000791	SIDE DEFLECTOR	2	2	2
7	8.01.53.00009500	BURNER ASSEMBLY	2	3	4
8	8.01.53.00000042	GAS TUBE BACK BRACKET	1	1	1
9	8.01.53.00000087	EXTERNAL BACK PANEL	1	1	1
10	---	STAINLESS STEEL SCREW 4.2 X 13 NT	27	26	27
11	---	INTERNAL FRAME ASSEMBLY	1	1	1
12	---	STAINLESS STEEL 4.5 X 10 NT OPEN RPX RIVET	17	24	30
13	8.01.52.00000788	EXTERNAL SIDE PANEL	2	2	2
14	---	RED FS UNC 1.4-20F X 1.2 ZB SCREW	2	2	2
15	8.09.03.00000400	LEG ASSEMBLY	4	4	4
16	---	THREDEAD RIVET	2	2	2
17	8.01.52.00002300	PILOT TUBE VALVE ASSEMBLY	0	1	0
18	8.01.52.00072500	PILOT TUBE ASSEMBLY	1	1	2
19	8.01.52.00074500	GAS DISTRIBUTION TUBE ASSEMBLY	1	1	1
20	8.01.53.00001900	KNOB ASSEMBLY	2	3	4
21	8.01.53.00000088	CRUMB/DRIP PAN	1	1	1
22	8.01.53.00000089	FRONT PANEL	1	1	1
23	8.01.52.00000796	24" CHARBROILER CRUMB/DRIP PAN AGCS	1	1	1
24	8.01.53.00000088	36" CHARBROILER CRUMB/DRIP PAN AGCS	1	1	1
25	8.01.53.00000103	48" CHARBROILER CRUMB/DRIP PAN AGCS	1	1	1

CRUMB/DRIP PAN CODES

Model 24" 8.01.52.00000796

Model 36" 8.01.53.00000088

Model 48" 8.01.53.00000103

PARTS DIAGRAM

COUNTERTOP GAS HOT PLATE

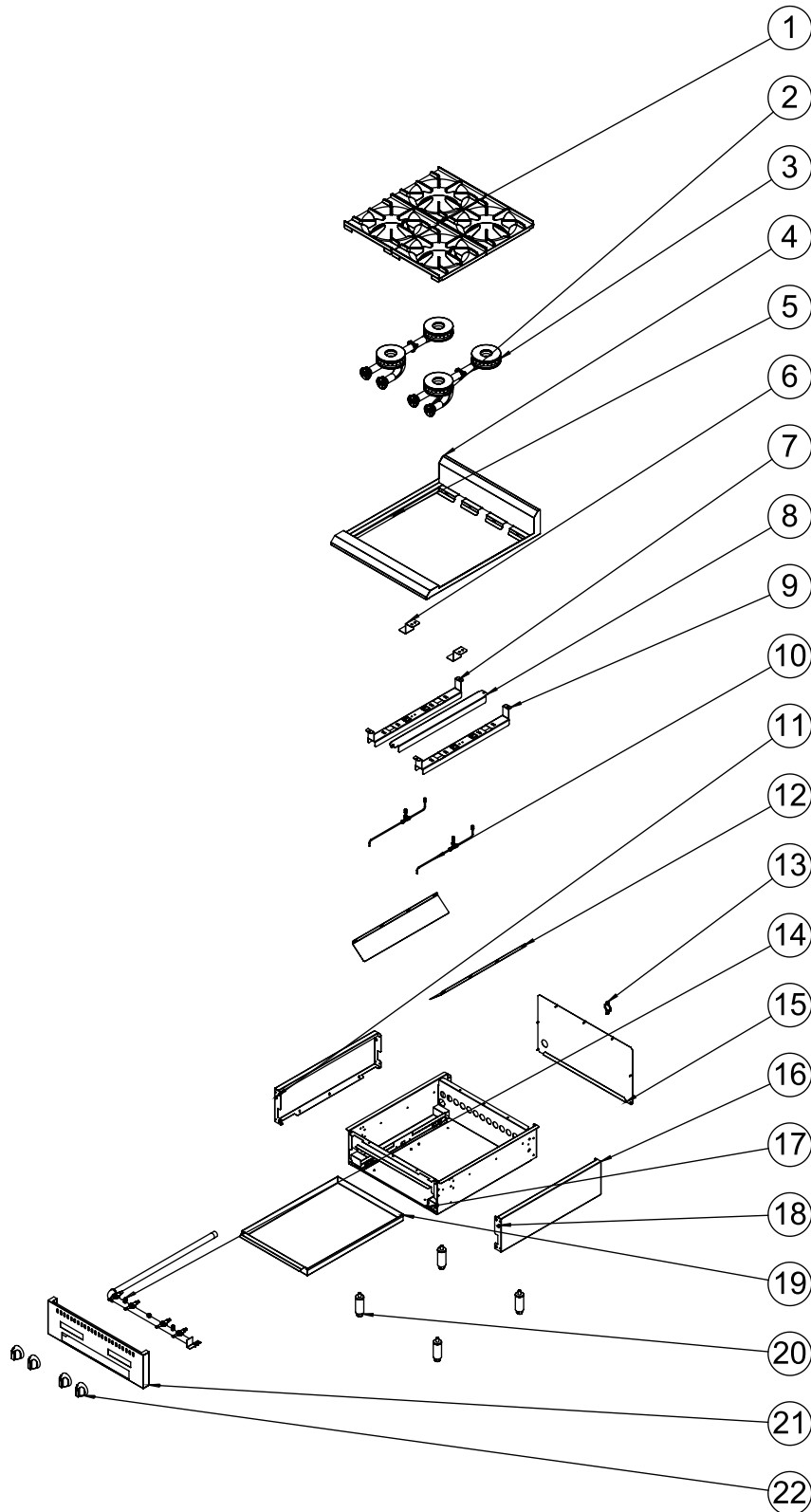

User Manual

PARTS LIST

COUNTERTOP GAS HOT PLATE

#	PART #	DESCRIPTION	PART QUANTITY BY MODEL (SIZE)		
			12"	24"	36"
1	8.01.25.00000110	TOP GRATE	2	4	6
2	8.01.53.00001700	BACK BURNER ASSEMBLY	1	2	3
3	8.01.53.00001600	FRONT BURNER ASSEMBLY	1	2	3
4	8.01.53.00001200	TOP FRAME ASSEMBLY	1	1	1
5	---	STAINLESS STEEL SCREW 4.2 X 13 NT	27	33	39
6	8.01.53.00000007	BACK BURNER BRACKET	1	2	3
7	---	STAINLESS STEEL 4.5 X 10 NT OPEN RPX RIVET	12	18	24
8	8.01.53.00000006	TOP GRATES SUPPORT BRACKET	0	1	2
9	8.01.53.00000005	BURNER SUPPORT BRACKET	1	2	3
10	8.01.53.00000100	PILOT ASSEMBLY	1	2	3
11	---	THREAD STEEL SX 1/4 ZA RIVET	2	2	2
12	8.01.53.00000008	CRUMB DEFLECTOR	2	2	1
13	8.01.53.00000042	GAS TUBE BACK BRACKET	1	1	1
14	8.01.53.00000700	GAS DISTRIBUTION TUBE ASSEMBLY	1	1	1
15	8.01.53.00000020	EXTERNAL BACK PANEL	1	1	1
16	8.01.53.00000017	EXTERNAL SIDE PANEL	2	2	2
17	8.01.53.00000300	WELDED INTERNAL FRAME ASSEMBLY	1	1	1
18	---	RED FS UNC 1.4-20F X 1.2 ZB SCREW	2	2	2
19	8.01.53.00000019	CRUMB/DRIP PAN	1	1	1
20	8.09.03.00000400	LEG ASSEMBLY	4	4	4
21	8.01.53.00000018	FRONT PANEL	1	1	1
22	8.01.53.00001900	KNOB ASSEMBLY	2	4	6
23	8.01.53.00000014	12" HOT PLATE CRUMB/DRIP PAN AGCS	1	1	1
24	8.01.53.00000019	24" HOT PLATE CRUMB/DRIP PAN AGCS	1	1	1
25	8.01.53.00000026	36" HOT PLATE CRUMB/DRIP PAN AGCS	1	1	1

CRUMB/DRIP PAN CODES

Model 12" 8.01.53.00000014

Model 24" 8.01.53.00000019

Model 36" 8.01.53.00000026



Equipment Limited Warranty

Avantco warrants its equipment to be free from defects in material and workmanship for a period of 1 year. This is the sole and exclusive warranty made by Avantco covering your Avantco brand equipment. A claim under this warranty must be made within **1 year** from the **date of delivery** of the equipment. Only the equipment's original purchaser may make a claim under this warranty. Avantco reserves the right to approve or deny the repair or replacement of any part or repair request. The warranty is not transferable. Avantco Equipment installed in/on a food truck or trailer will be limited to a period of **30 days** from the original date of delivery.

To Make a Warranty Claim:

For Warranty Inquiries contact the location where you purchased the product:

- **WebstaurantStore.com:** Contact help@webstaurantstore.com. Please have your order number ready.
- **The Restaurant Store:** If you purchased this unit from your local store, please contact your store directly.
- **TheRestaurantStore.com:** Online purchases, call 717-392-7261. Please have your order number ready.

Failure to contact the designated location prior to obtaining equipment service may void your warranty.

Avantco makes no other warranties, express or implied, statutory or otherwise, and **HEREBY DISCLAIMS ALL IMPLIED WARRANTIES, INCLUDING THE IMPLIED WARRANTIES OF MERCHANTABILITY AND OF FITNESS FOR A PARTICULAR PURPOSE.**

This Limited Warranty does not cover:

- Equipment sold or used outside the Continental United States
- Use of unfiltered water (if applicable)
- Avantco has the sole discretion on wearable parts not covered under warranty
- Equipment not purchased directly from an authorized dealer
- Equipment used for residential or other non-commercial purposes
- Equipment that has been altered, modified, or repaired by anyone other than an authorized service agency
- Equipment where the serial number plate has been removed or altered.
- Damage or failure due to improper installation, improper utility connection or supply, and issues resulting from improper ventilation or airflow.
- Defects and damage due to improper maintenance, wear and tear, misuse, abuse, vandalism, or Act of God.

Any action for breach of this warranty must be commenced within 1 year of the date on which the breach occurred. No modification of this warranty, or waiver of its terms, shall be effective unless approved in a writing signed by the parties. The laws of the Commonwealth of Pennsylvania shall govern this warranty and the parties' rights and duties under it. Avantco shall not under any circumstances be liable for incidental or consequential damages of any kind, including but not limited to loss of profits.