



## Electric Countertop Food Warmers/Cookers



**Models:**

177W50, 177W50CKR, 177W43

01/2021

*UNITS MUST BE KEPT CLEAR OF COMBUSTIBLES AT ALL TIMES*

***Please read and save these instructions for future reference. Indoor use only.***

**NOTE: Save these instructions for future reference.**

## Index

Owners Information .....	4
Safety Warnings .....	4
Specifications .....	6
Operating Instructions .....	7
General Cleaning.....	8
Troubleshooting.....	9
Wiring Diagram.....	10
Parts.....	11
Warranty.....	14

## Owner's Information



Please complete this information and retain this manual for the life of the equipment. For warranty purposes, please fill out and retain this information. An example of the serial plate(s) for these units are included below for reference.

Model No. \_\_\_\_\_

Serial No. \_\_\_\_\_

Date of Purchase: \_\_\_\_\_

### Serial Plate Example:

	MADE IN CHINA
ITEM: 177W50	
MODEL : 177W50	
DESCRIPTION : WARMER 12x20 INFINITE CONTROL	
VOLTAGE : 120V ~ 60 Hz	
WATTAGE : 1200W	
SERIAL # :	
	

Avantco Electric Countertop Food Warmers are designed to keep foods at optimum serving temperatures without affecting quality. They are built for tough kitchen duty with rugged stainless steel construction and simply dial controls. Food Warmers keep everything from meat to vegetables to rolls hot and flavor-fresh until served, with easy control for a variety of foods through the built-in digital controls with independent readout screens for set and actual temperatures.

This manual provides the installation, safety, and operating instructions for Food Warmers. Avantco recommends all installation, operating, and safety instructions appearing in this manual to be read prior to installation or operation of the unit.

## Safety Warnings

Avantco Food Warmers are designed, built, and sold for commercial use and should be operated by trained personnel only. Clearly post all CAUTIONS, WARNINGS, and OPERATING INSTRUCTIONS near each unit to ensure proper operation and to reduce the chance of personal injury and/or equipment damage.

**WARNING:** Do not store or use gasoline or other flammable vapors and liquids in the vicinity of this or any other appliance. Keep the area free and clear of combustible materials.

**WARNING:** Improper installation, adjustment, alteration, service, or maintenance can cause property damage, injury, or death. Read the Installation, Operating, and Maintenance Instructions thoroughly before installing or servicing this equipment.

**CAUTION:** These models are designed, built, and sold for commercial use only. If these models are positioned so the general public can use the equipment, make sure all cautions, warnings, and operating instructions are clearly posted near each unit so that anyone using the equipment can use it correctly and not injure themselves or the equipment.

**CAUTION:** Make sure food product has been heated to the proper food-safe temperature before placing in unit. Failure to heat food product properly may result in serious health risks. This unit is for holding preheated food product only.

**CAUTION:** Locate unit in an area that is convenient for use. The location should be level and strong enough to support the weight of the unit and contents.

## **ELECTRIC SHOCK HAZARD**

- Wire unit into properly grounded electrical panel of the correct voltage, size, and configuration.
- Turn OFF power switch, unplug power cord/turn off power at circuit breaker, and allow unit to cool before performing any cleaning, adjustments, or maintenance.
- DO NOT submerge or saturate with water. Unit is not waterproof. Do not operate if unit has been submerged or saturated with water.
- Unit is not weatherproof. Locate unit indoors where ambient air temperature is a minimum of 70°F (21°C).
- Do not clean unit when it is energized or hot.
- Do not steam clean or use excessive water on the unit.
- This unit is not “jet-proof” construction. Do not use jetclean spray to clean this unit.
- Do not pull unit by power cord.
- Discontinue use if power cord is frayed or worn.
- This unit must be serviced by qualified personnel only. Service by unqualified personnel may lead to electric shock or burn.

## **FIRE HAZARD**

- Locate unit a minimum of 1" (25 mm) from combustible walls and materials. If safe distances are not maintained, discoloration, or combustion could occur. Do not use harsh chemicals such as bleach (or cleaners containing bleach), oven cleaners, or flammable cleaning solutions to clean this unit. Use warm soapy water. Reference cleaning instructions on page 9-10 for more information.

## **BURN HAZARD**

- Some exterior surfaces on unit will get hot.
- Use caution when removing steam table pans from wells. Hot air escapes when a pan is removed.

# User Manual

## Specifications

- Cordset Configuration: 120V: NEMA5-15P plug, 3 wire grounded cord.
- If the supply cord is damaged, the manufacturer or an authorized service agent or a similarly qualified person must replace it to avoid a hazard or voiding the warranty.

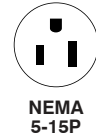

Model	177W50	177W50CKR	177W43
Style	Warmer	Warmer/Cooker	Warmer
Well Size	Full - 12" x 20"	Full - 12" x 20"	4/3 12" x 27"
# of Wells	1	1	1
Max Pan Depth	4"	4"	4"
Voltage	120V	120V	120V
Wattage	1200W	1500W	1500W
Plug Config.	5-15P	5-15P	5-15P
Temp Range	80 - 160°F	120 - 212°F	80 - 160°F

## Operating Instructions

### General Information

- Always clean equipment thoroughly before first use
- Check rating label for your model designation and electrical rating
- Ensure unit is properly installed by a qualified electrician

**WARNING: ELECTRICAL SHOCK HAZARD. FAILURE TO FOLLOW THE INSTRUCTIONS IN THIS MANUAL COULD RESULT IN SERIOUS INJURY OR DEATH.** Electrical Ground is required on this appliance. Do not modify the power supply cord plug. If it does not fit into the outlet, have the proper outlet installed by a qualified electrician. Do not use an extension cord with this appliance. Check with a qualified electrician if you are unsure as to whether the appliance is properly grounded.

### General Operating Instructions:

- All foodservice equipment should be operated by trained personnel.
- Do not place arms or hands or other objects not desired to be heated in the well.
- Use caution when removing pans from wells, use hot mitts where appropriate.
- Never pour cold water into wells, always use warm or hot water for best performance.
- Do not cook, warm or hold food directly in liner pans (well pans). Always use steamtable pans/insets, etc.
- Never hold perishable food below 150°F (66°C).

### Installation and First Use Instructions

**CAUTION:** Food Warmers are heavy and may require two people to install

1. Remove unit from carton and all packaging materials from the unit.
2. Remove the manual/information packet from the unit.
3. Place unit in desired location.

NOTE: Place where the ambient air temperature is constant and a minimum of 70°F. Avoid areas that are subject to active air movements or currents. Make sure the unit is located on a solid, level area and at a proper height for convenient use and also following health standards.

## Installation and First Use Instructions (continued)

4. Fill the unit with warm/hot water up to the “MAX” fill line but not below the “MIN” fill line.  
**NOTE:** Failure to keep proper water level may result in lower performance or even burnout
5. Locate an outlet of the correct plug and voltage type for the unit and plug in
6. Turn the dial control the desired heat intensity
7. Allow the unit up to 25 minutes to preheat (covering with a steam table pan will allow quicker preheating. **NOTE:** Initial heating of unit may generate smoke or fumes and must be done in a well-ventilated area. This is standard and may last up to 60 minutes during initial startup. Operate unit without food until smoke and fumes have dissipated
8. Once preheated by comparing the Set Temperature readout to the Actual Temperature readout, place pre-cooked food product directly in stainless steel drawer pans or use a combination of different compatible sizes of food pans up to 4” (152mm) deep
9. When the unit is no longer needed during the day, or needs to be cleaned, turn the unit “OFF” and allow up to 1 hour to cool down. Once cool, empty the well and complete necessary procedure. Removing any steam table pans will accelerate the cooldown process.

## General Cleaning Instructions

- **NEVER** clean any electrical unit by immersing it in water. Turn off before surface cleaning.
- Always clean equipment thoroughly before first use. Clean unit daily. Except where noted on charts: Use warm, soapy water. Mild cleansers and PLASTIC scouring pads may be used to remove baked-on food and water scale.
- Turn off electrical units before cleaning or servicing.

### General Cleaning Information

- Follow General Cleaning Instructions (above).
- Remove any inset pans and pans. Wash thoroughly in the sink or dishwasher.
- If Lime or Mineral build-up occurs, follow below guide on “Removing Lime and Mineral Deposits”.

### Removing Lime Mineral Deposits:

Turn unit off the unit, and allow the unit to cooldown.

1. After the unit has cooled, remove and empty the water pan.

2. Fill the water pan with a mixture of 75% water and 25% white vinegar to a level where it covers the lime and mineral deposits.
3. Install the water pan with deliming solution into the unit.
4. Plug in and turn on the unit. Allow the unit to run for 30 minutes.
5. Turn off the unit and unplug the power cord.
6. Allow the water pan to stand with the deliming solution for at least two hours (the time required will vary depending on the amount of deposits in the water pan).
7. Remove the water pan and empty the deliming solution.
8. Continue to fill and rinse the water pan with clean water until the pan is clean.
9. Install the clean water pan into the unit. Plug in the unit and fill the water pan as usual for daily operation (1/4" of water is recommended). **NOTE:** If lime and mineral deposits are still present in the water pan, repeat this procedure and increase the amount of time the de-liming mixture stands in the water pan.

## Troubleshooting

Issue	Potential Cause	Solution
<b>Unit is too hot</b>	Temperature control is set too high	Change the temperature to a lower setting
	Unit is connected to incorrect power supply	Contact an authorized electrician
	Defective internal thermostat	Contact an authorized electrician
<b>Unit is not hot enough</b>	Unit has not had enough time to preheat	Allow unit 25 minutes to reach operating temperature. This can be accelerated by placing a steam table pan in the well
	Temperature control is set too low	Change the temperature to a higher setting
	Defective internal thermostat	Contact an authorized electrician
	Water level is low	Fill well with warm/hot water up to "MAX" fill line
<b>Unit is not working at all</b>	Unit is not plugged in	Plug unit into proper power supply
	Unit not turned on	Turn unit ON by using On/Off power button
	Circuit breaker tripped	Reset circuit breaker
	Control panel is defective	Contact an authorized electrician
	Defective internal thermostat	Contact an authorized electrician
	Heating element is burned out	Contact an authorized electrician

# User Manual

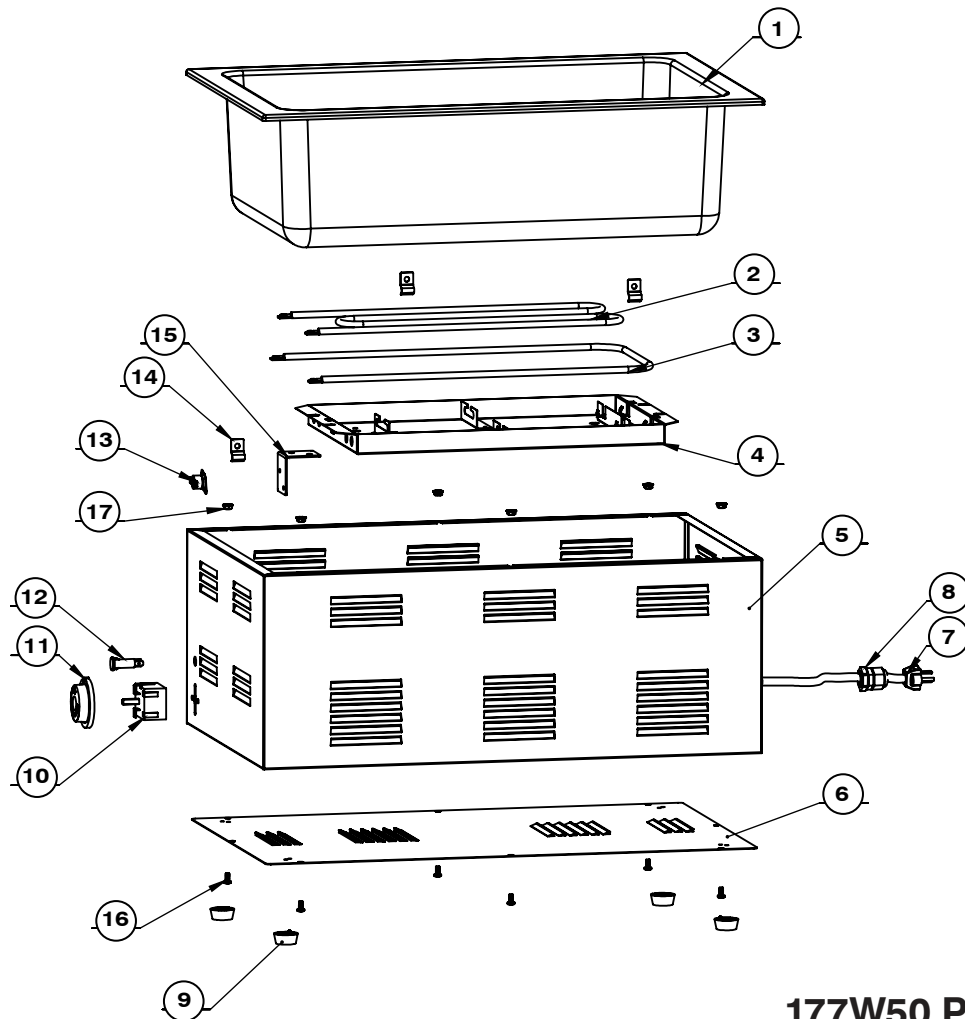

**177W50 Parts List**

Item	Qty	Part #	Description
1	1	425001	Well
2	1	425002	Heating Element 1
3	1	425003	Heating Element 2
4	1	425004	Dissipator Plate
5	1	425005	Body
6	1	415005	Bottom Cover
7	1	B00064	Power Cord
8	1	B00065	Bushing
9	4	B00063	Plastic Pad
10	1	B00066	Thermostat
11	1	B00067	Knob
12	1	B00068	Pilot Light
13	1	B00069	Limit Thermostat
14	5	415006	Clamp
15	1	415007	L-Shaped Plate
16	12	B00060	M4x9 Self-tapping Screw
17	17	B00062	M5 Flange Nut

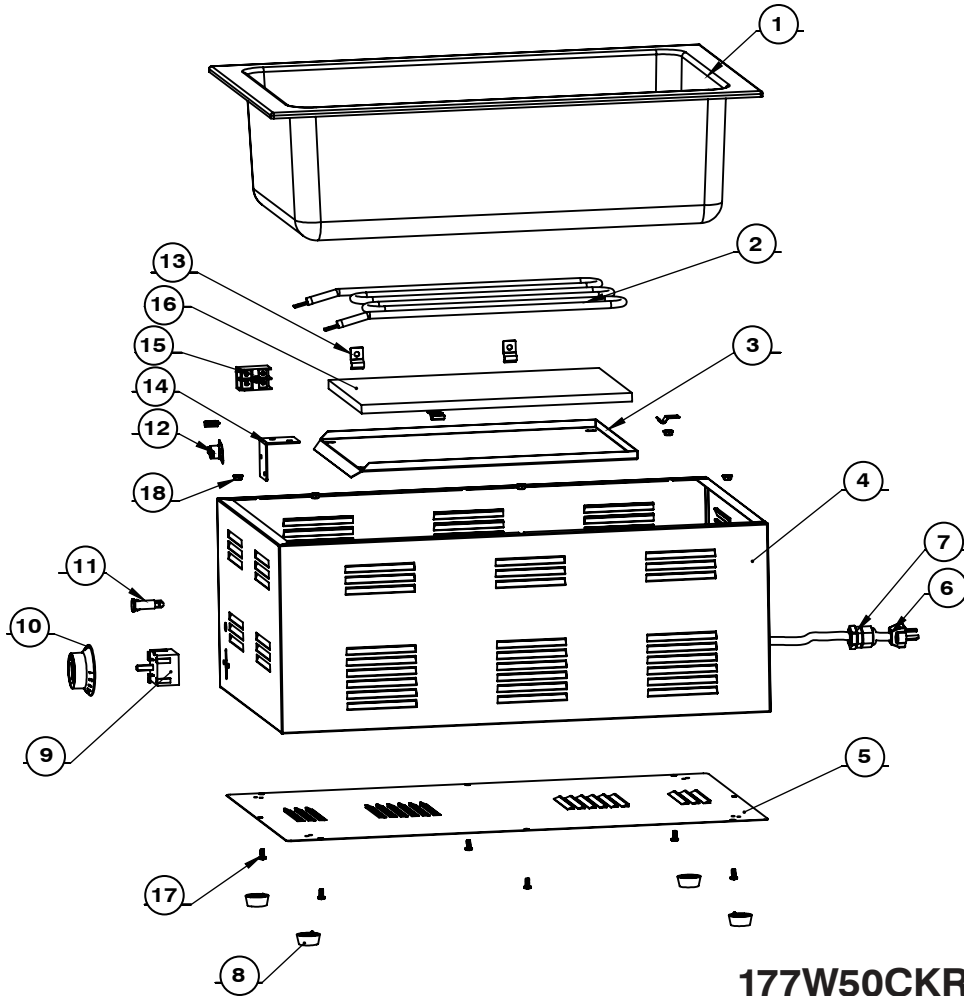

**177W50CKR Parts List**

Item	Qty	Part #	Description
1	1	415001	Well
2	1	415002	Heating Element 1
3	1	415003	Dissipator Plate
4	1	415004	Body
5	1	415005	Bottom Cover
6	1	B00055	Power Cord
7	1	B00065	Bushing
8	4	B00063	Plastic Pad
9	1	B00066	Thermostat
10	1	B00067	Knob
11	1	B00068	Pilot Light
12	1	B00069	Limit Thermostat
13	5	415006	Clamp
14	1	415007	L-Shaped Plate
15	1	B00070	Terminal Block
16	1	B00071	Insulation Foam
17	10	B00060	M4x9 Self-tapping Screw
18	18	B00062	M5 Flange Nut

# User Manual

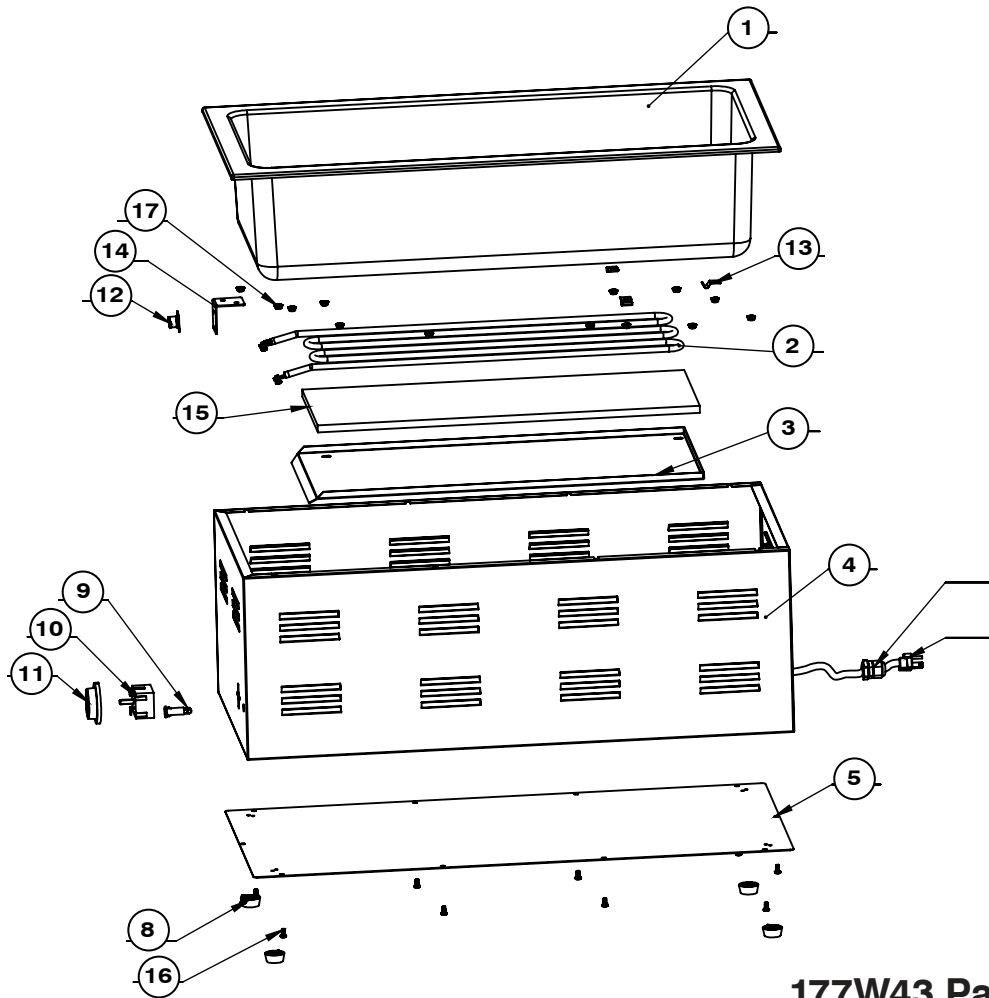

## 177W43 Parts List

Item	Qty	Part #	Description
1	1	435001	Well
2	1	435002	Heating Element
3	1	435003	Dissipator Plate
4	1	435004	Body
5	1	435005	Bottom Cover
6	1	B00064	Power Cord
7	1	B00065	Bushing
8	4	B00063	Plastic Pad
9	1	B00068	Pilot Light
10	1	B00066	Thermostat
11	1	B00067	Knob
12	1	B00069	Limit Thermostat
13	6	415006	Clamp
14	1	415007	L-Shaped Plate
15	1	B00072	Insulation Foam
16	12	B00060	M4x9 Self-tapping Screw
17	20	B00062	M5 Flange Nut

## Equipment Limited Warranty

Avantco warrants its equipment to be free from defects in material and workmanship for a period of 1 year. This is the sole and exclusive warranty made by Avantco covering your Avantco brand equipment. A claim under this warranty must be made within **1 year** from the **date of purchase** of the equipment. Only the equipment's original purchaser may make a claim under this warranty. Avantco reserves the right to approve or deny the repair or replacement of any part or repair request. The warranty is not transferable. Avantco Equipment installed in/on a food truck or trailer will be limited to a period of **30 days** from the original date of purchase.

### To Make a Warranty Claim:

For Warranty Inquiries contact the location where you purchased the product:

- WebstaurantStore.com: Contact [help@webstaurantstore.com](mailto:help@webstaurantstore.com). Please have your order number ready.
- The Restaurant Store: If you purchased this unit from your local store, please contact your store directly.
- TheRestaurantStore.com: Online purchases, call 717-392-7261. Please have your order number ready.

Failure to contact the designated location prior to obtaining equipment service may void your warranty.

Avantco makes no other warranties, express or implied, statutory or otherwise, and HEREBY DISCLAIMS ALL IMPLIED WARRANTIES, INCLUDING THE IMPLIED WARRANTIES OF MERCHANTABILITY AND OF FITNESS FOR A PARTICULAR PURPOSE.

This Limited Warranty does not cover:

- Equipment sold or used outside the Continental United States
- Use of unfiltered water (if applicable)
- Avantco has the sole discretion on wearable parts not covered under warranty
- Equipment not purchased directly from an authorized dealer
- Equipment used for residential or other non-commercial purposes
- Equipment that has been altered, modified, or repaired by anyone other than an authorized service agency
- Equipment where the serial number plate has been removed or altered.
- Damage or failure due to improper installation, improper utility connection or supply, and issues resulting from improper ventilation or airflow.
- Defects and damage due to improper maintenance, wear and tear, misuse, abuse, vandalism, or Act of God.

Any action for breach of this warranty must be commenced within 1 year of the date on which the breach occurred. No modification of this warranty, or waiver of its terms, shall be effective unless approved in a writing signed by the parties. The laws of the Commonwealth of Pennsylvania shall govern this warranty and the parties' rights and duties under it. Avantco shall not under any circumstances be liable for incidental or consequential damages of any kind, including but not limited to loss of profits.