



Gas Donut Fryers



02/2022

Models: 177FBF1824LP, 177FBF1824NG,
177FBF2424LP, 177FBF2424NG

WARNING

Improper installation, adjustment, alteration, service, or maintenance can cause property damage, injury, or death.
Read the installation, operating, and maintenance instructions thoroughly before installing or servicing this equipment.

Please read and keep these instructions. Indoor use only.

IMPORTANT FOR YOUR SAFETY

This manual has been prepared for personnel qualified to install gas equipment, who should perform the initial field start-up and adjustments of the equipment covered by this manual.

Post in a prominent location the instructions to be followed in the event the smell of gas is detected. This information can be obtained from the local gas supplier.

IMPORTANT

In the event a gas odor is detected, shut down units at the main shutoff valve and contact the local gas company or gas supplier for service.

FOR YOUR SAFETY

Do not store or use gasoline or other flammable vapors or liquids in the vicinity of this or any other appliance.

GENERAL

Our gas tube donut fryers are produced with quality workmanship and material. Proper installation, usage, and maintenance will result in years of satisfactory performance.

Before installing the fryer, thoroughly read this manual and carefully follow all instructions.

This manual is applicable to models listed below. Procedures in this manual will apply to all models unless specified. Pictures and illustrations can be of any model unless the picture or illustration needs to be model specific.

UNPACKING

This fryer was carefully inspected before leaving the factory. Upon acceptance of the shipment, the transportation company assumes full responsibility for safe delivery.

Immediately after unpacking the fryer, check for possible shipping damage. If the fryer is damaged, save the packaging material and contact the carrier immediately.

Index

Safety	2
General	2
Unpacking	2
Specifications	4
Installation	5
Codes and Standards	7
Assembly	8
Flue Connection	8
Gas Connection	9
Leveling the Fryer	10
Operation	11-15
Cleaning	15
Boil Out Procedure	16
Maintenance	17
Flue Vent Inspection	17

SPECIFICATIONS DIMENSIONS

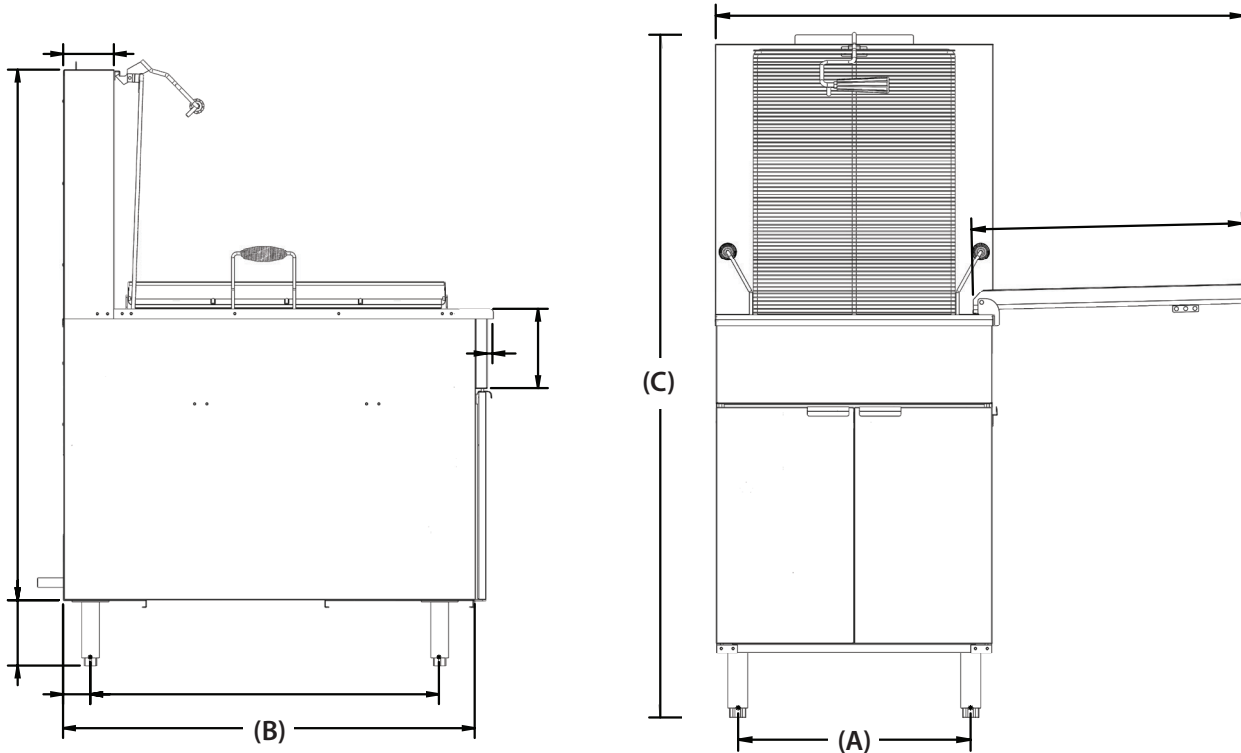

GAS SUPPLY INFORMATION

Supply pressure should be minimum of 4"W.C. for natural gas or 10"W.C. for propane. The fryer comes with 3/4" NPT male connector on a 1/2" pipe, allowing you to connect with either 3/4" or 1/2" NPT female connector.

MODEL	GAS TYPE	MANIFOLD PRESSURE	(A) WIDTH	(B) DEPTH	(C) HEIGHT
177FBF1824LP	Liquid Propane	10" W/C	24"	41 1/4"	58"
177FBF2424LP		10" W/C	29 1/2"	41 1/4"	58"
177FBF1824NG	Natural Gas	4" W/C	24"	41 1/4"	58"
177FBF2424NG		4" W/C	29 1/2"	41 1/4"	58"

*Minimum supply pressure 4" is W.C. for natural gas and 10"W.C. for propane.

INSTALLATION

Do not use the door or its handle to lift the fryer.

Before installing the fryer, verify that the type of gas (natural or propane) is in conformity to the specifications on the fryer data plate, which is located on the inside of the door panel. Make sure the fryer is configured for the proper elevation.

Clearances

- Minimum clearance from combustible construction:

Minimum clearance from noncombustible construction	
Sides of Fryer	6"
Back of Fryer	6"



NOTE
All avantco donut fryers shall be installed with at least a 16 inch space between the fryer and Surface flames from adjacent equipment

The fryer may be installed on combustible floors

Minimum clearance from noncombustible construction	
Sides of Fryer	0"
Front of Fryer	0"
Between the fryer and any open-top flame units	16" (41 cm)

Allow space for servicing and operation.

Location

- Install fryer in an area with sufficient air supply for gas combustion at fryer burners.
- Do not obstruct the flow of combustion and ventilation air.
- Provide adequate clearance for air openings into the combustion chamber.
- Do not permit fans to blow directly onto fryer.
- Avoid wall-type fans, which create cross-currents within a room. Avoid open windows next to sides or back.

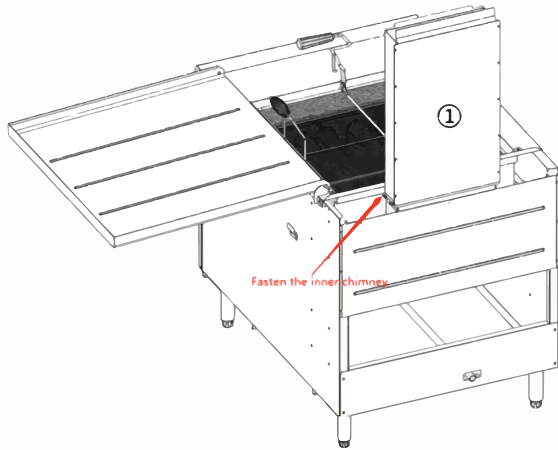

Take out the inner chimney. ① Please fasten the inner chimney to the inner chimney support using four screws.

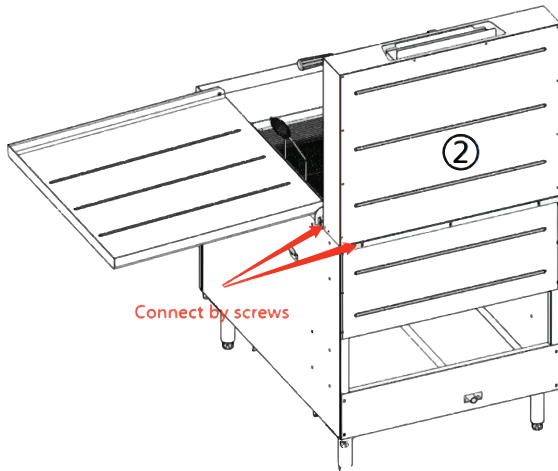

Take out the outside chimney. ② Please connect the outside chimney using screws

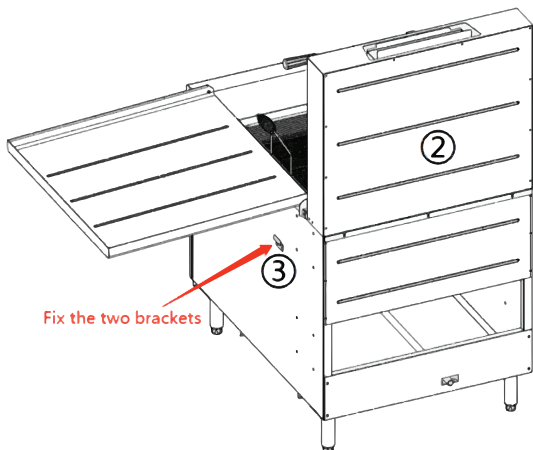

Fix the two supporting brackets. The lid extending direction can be at either right or left side.

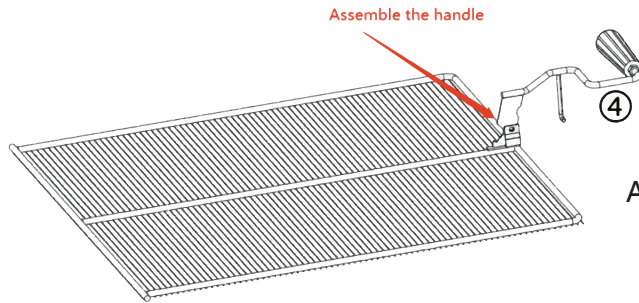

Assemble the handle using the screws provided.

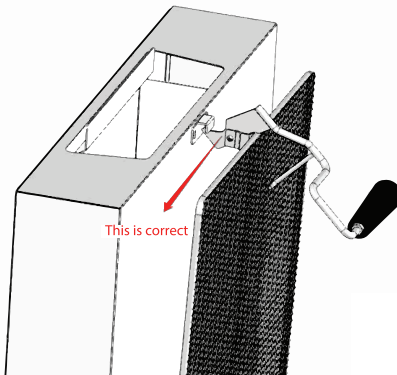

Attach handle.

CODES AND STANDARDS

The fryer must be installed in accordance with:

In the United States:

- State and local codes, or in the absence of local codes, with:

- National Fuel Gas Code, ANSI-Z223.1/NFPA #54 (latest edition). Copies may be obtained from The American Gas Association Accredited Standards Committee Z223, @ 400 N. Capital St. NW, Washington, DC 20001 or the Secretary Standards Council, NFPA, 1 Batterymarch Park Quincy, MA 02169-7471.
- NFPA Standard #96 Vapor Removal from Cooking Equipment, latest edition, available from the National Fire Protection Association, Batterymarch Park, Quincy, MA.
- National Electrical Code, ANSI/NFPA-70 (latest edition). Copies may be obtained from The National Fire Protection Association, Batterymarch Park, Quincy, MA. 02169-7471.
- In the commonwealth of Massachusetts all gas appliances vented through a ventilation hood or exhaust system with a damper or with a power means of exhaust shall comply with 248 CMR.

In Canada:

- Local codes
- CAN/CSA-B149.1 Natural Gas and Propane Installation Code (latest edition), available from the Canadian Standards Association, 155 Queen Street, Suite 1300, Ottawa, Ontario Canada K1P 6L1.
- CSA C22.1 Canadian Electric Code (latest edition), available from the Canadian Standards Association, 155 Queen Street, Suite 1300, Ottawa, Ontario Canada K1P 6L1.

ASSEMBLY

The fryer must be restrained to prevent tipping and the splashing of hot liquid. The means of restraint may be the manner of installation, such as connection to a battery of appliances, installing the fryer in an alcove, or by separate means such as adequate ties.

FLUE CONNECTION

Make the flue connection as follows:

- Comply with Vapor Removal from Cooking Equipment, ANSI-NFPA Standard #96 (latest edition), available from the National Fire Protection Association, Batterymarch Park, Quincy, MA 02269.
- Locate the fryer under a hood with adequate connection to an exhaust duct. The hood must extend 6" (15 cm) beyond fryer on both sides.
- Clearance above the fryer should be adequate for combustion byproducts to be removed efficiently.
- An 18" (46 cm) minimum clearance should be maintained between the flue vent and the filters of the hood venting system.
- Never make flue connections directly to the fryer.

- Do not obstruct the flow of the gases from the appliance. Proper air balance should be maintained in the room.
- Ensure that your ventilation system does not cause a down draft at the fryer's flue opening. Down draft will not allow the fryer to exhaust properly and will cause overheating which may cause permanent damage. Damage caused by down draft will not be covered under equipment warranty. Never allow anything to obstruct the flue or ventilation exiting from the fryer flue. Do not put anything on top of flue area.

GAS CONNECTION



WARNING

Prior to lighting, check all joints in the gas supply line for leaks. Use soap and water solution.

Do not use an open flame

After piping has been checked for leaks, fully purge gas pipes to remove air.
1/2 Gas connection, 12/ to 3/4 adapter included in the unit.

GAS PRESSURES (ALL MODELS):

The gas pressure should be set at 4" W.C. (Water Column) (0.8 kPa) for natural gas and 10" W.C. (2.75 kPa) for propane gas. If incoming pressure exceeds 1/2 PSI (3.45 kPa), an additional pressure regulator must be installed.

TESTING THE GAS SUPPLY PIPING SYSTEM:

When test pressures exceed 1/2 PSI (3.45 kPa), the fryer and its individual shutoff valve must be disconnected from the gas supply piping system.

When test pressures are 1/2 PSI (3.45 kPa) or less, the fryer must be isolated from the gas supply piping system by closing its individual shutoff valve.

Fryers with Casters:

Separate instructions for installing casters are included with the casters:

- The installation shall be made with a connector that complies with the Standard for Connectors for Movable Gas Appliances, ANSI Z21.69, CAN/CGA-6.16, and a quick disconnect device that complies with the Standard for Quick-Disconnect Devices for Use with Gas Fuel, ANSI z21.41 CSA 6.9 or Quick-Disconnect Devices for Use with Gas Fuel.
- When installing a quick disconnect you must also install a means for limiting the movement of the fryer. This device will prevent the gas line or quick disconnect from being strained. The restraining device should be attached to the cutout on the back panel. See illustration for location.

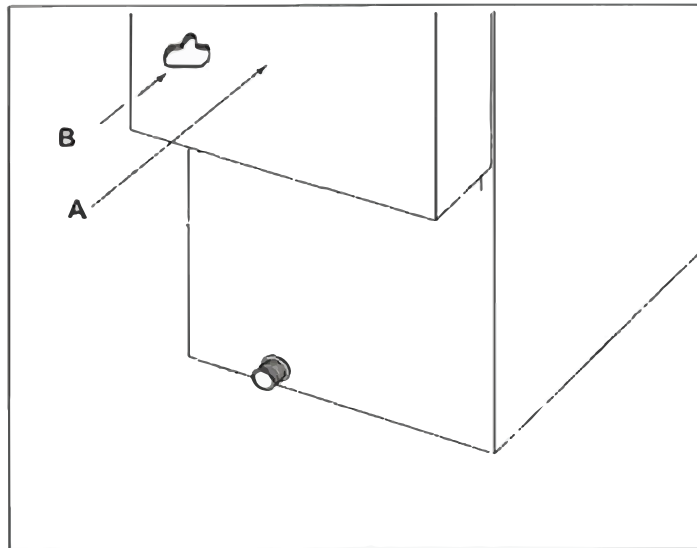

A Rear of Fryer

B Strain Relief Chain Connection (Chain supplied by others)

- The fryer must be installed with a connector (not supplied by Factory) complying with the above codes.
- The fryer must be installed with restraining means to guard against transmission of strain to the connector. See illustration.
- The fryer must be installed with the casters provided.
- If the restraint is ever to be disconnected, first turn the gas supply off. If disconnection of the restraint is necessary, to reconnect this restraint after the fryer has been returned to its originally installed position.

LEVELING THE FRYER

- Check the level of the fryer by placing a level on top of the fryer after gas connections have been made.
- Ensure that the fryer is level front-to-back and side-to-side in the final installed position.
- Lock the wheels after unit is level.

OPERATION



WARNING

Hot oil and parts can cause burns. Use care when operating, cleaning, and servicing the fryer.



WARNING

Spilling hot frying compound can cause severe burns. Do not move fryer without draining all frying compound from the tank.



WARNING

Fryer is not to be used during a power outage.

HIGH LIMIT CONTROL

Avantco Donut Fryers are equipped with a secondary heat control that prevents the oil temperature from rising above 450°F. (Because of the accuracy tolerance of the sensor, the oil temperature may reach as high as 475°F.)

If the fryer shuts down due to overheating, DO NOT relight the pilot until the shortening temperature is below 300 F (149 C).

If an overheating situation persists, contact your local authorized service office.

BEFORE FIRST USE

Cleaning

New units are wiped down at the factory to remove any visible signs of dirt, oil, grease, etc. remaining from the manufacturing process.

Before any food preparation, thoroughly wash the protective oil from all surface parts and the tank interior with hot soapy water to remove any film residue and dust or debris.

NOTICE

Do not use chlorine or sulfate/sulfide cleaners.

- Wash any accessories shipped with unit.
- Rinse fryer and accessories thoroughly and drain the fryer.
- Wipe tank completely dry with a soft, clean cloth.

FILLING TANK WITH SHORTENING

NOTICE

Solid shortening must NOT be used with this fryer. Melting solid shortening will damage the tank and void your warranty.



WARNING

NEVER melt blocks of solid shortening on top of the heat tubes. This would cause a fire and could result in personal injury.

- Close the drain valve.
- Fill the fryer tank with liquid shortening.
- Shortening level should be between the min and max lines in the fryer tank.
- Shortening will expand when heated. Do not fill the fryer tank over the MAX line.
- Add fresh shortening as needed to maintain oil level.

LIGHTING THE PILOT

1. Open the door.
2. Make sure that thermostat is set to OFF. The thermostat is located behind the door.
3. Push the gas control valve knob and turn to OFF. Wait 5 minutes for unburned gas to vent.
4. Push and turn gas control valve knob to the “L” in PILOT (see figure below).

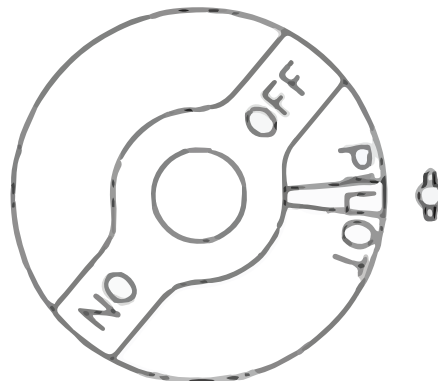

5. While pressing the knob down, use a lit match to ignite the pilot. Continue to press the knob down for about 30 seconds.
6. When the pilot stays lit, turn the knob counterclockwise to the “ON” position. Do not press down on the knob in this step. (See figure below).
7. If gas supply is interrupted, repeat steps 2 through 6.
8. Do NOT turn the thermostat “ON” until the fry pot is filled with oil or solid shortening.
9. Once the fry pot is filled with shortening, set the thermostat to the desired temperature

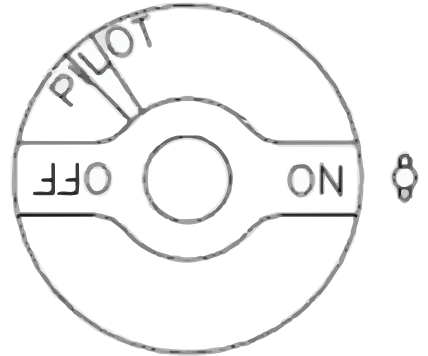

TURNING ON THE FRYER

1. Set the temperature knob to desired temperature.
2. After the set temperature has been reached, the thermostat shuts off the gas flow to burners.
3. The pilot remains lit. The burners will cycle on and off, maintaining the set temperature.

TURNING OFF THE FRYER

1. Turn the thermostat OFF.
2. To keep the pilot lit, turn the gas valve to “L” in Pilot.
3. To shut off all gas to the system, including the pilot, turn the gas valve knob to the OFF position.

EXTENDED SHUTDOWN

1. Turn the thermostat knob to OFF.
2. Push in the pilot knob and turn to OFF.
3. Thoroughly drain the fryer. Refer to DRAINING THE FRYER.
4. Clean the fryer according to CLEANING.
5. Turn off the main gas shutoff valve.

BASIC FRYING INSTRUCTIONS

- Set the desired temperature and allow shortening to heat up to that temperature.
- Fry items that are the same size to ensure equal doneness.
- Drain or wipe dry raw or wet foods to minimize splatter when lowering into hot shortening.
- Add fresh shortening as needed.

Fry Basket Guidelines

- When frying doughnuts and fritters, turn product only once during frying.
- When frying is completed, take out the supporting wiring rack and place it on the lid.

EXTENDED SHORTENING LIFE

Shortening life can be extended by the following guidelines:

- Do not salt foods over the fryer.
- Use good-quality shortening.
- Filter shortening daily (at a minimum).
- Keep equipment and surrounding clean.
- Set thermostat correctly.
- Remove excess moisture and particles from food products before placing on fryer.



Tough on grease, Tough on carbon, and increases life of Oils.

DRAINING THE OIL

 **WARNING**

Hot oil and hot parts can cause burns. Use care when operating, cleaning, and servicing the fryer.

1. Turn the thermostat knob to the OFF position.
2. Insert the drain extension into the drain valve. Tighten only hand tight.
3. Direct the drain extension into the mobile filtering device that you want to use.
4. Slowly open the drain valve to allow oil to flow from the fry tank to the filter pan. Then open the drain valve all the way.
5. When fry tank is empty brush to remove any additional debris.
6. Close the drain valve.
7. Fill tank with new shortening. Fill to a minimum of the MIN level but no higher than halfway between MIN and MAX. Oil will expand as it is heated. Add Fryclone oil stabilizer and filter powder to oil. This will extend the life of your oil (item # 147FCPWDR4G)
8. After the fry tank is filled with new oil, turn the thermostat knob to the desired set temperature. The burners will come on and will heat the oil.

CLEANING

 **WARNING**

Hot oil and hot parts can cause burns. Use care when operating, cleaning, and servicing the fryer.

Daily

Internal Cleaning

Clean your fryer regularly with cleaning brush along with a damp cloth, and polish with a soft dry cloth. If regular cleaning is neglected, grease will be burned on and discolorations may form.

External Cleaning

- Clean all exterior surfaces of your fryer at least once daily.
- Use a damp cloth with warm water and a mild soap or detergent.

NOTICE

Do not use chlorine or sulfate/sulfide cleaners.

- Rinse thoroughly, and then polish with a soft dry cloth.
- Keep the fryer exterior clean and free of accumulated grease to prevent stubborn stains from forming. If regular cleaning is neglected, grease will be burned on and discolorations may form.
- Remove discolorations by washing with any detergent or soap and water.
- Use a self-soaping, non-metallic scouring pad for particularly stubborn discolorations.
- Always rub with the grain of the stainless steel.
- Do not use a metallic scoring pad or harsh cleaners.

BOIL OUT PROCEDURE

Weekly or as required:

1. Drain the tank as described under DRAINING THE OIL.
2. Once the shortening has been drained, flush out scraps and sediment using the cleaning brush.
3. Close the drain valve and fill tank with water. Use a low foaming cleaner/degreaser to clean the fry tank. (#999FCBOILOUT) Follow the instructions on the side of the package.

NOTICE

Do not use chlorine or sulfate/sulfide cleaners.

4. Solution level must be between the MIN and MAX levels on the fryer tank.
5. Set the temperature knob to 200°F or for the recommended solution being used. Allow solution to simmer for about 15 to 20 minutes.
6. Turn off main burners and let the solution stand. Scrub the fry pot walls and heat tubes. Drain the cleaning solution from the tank.
7. Close the drain valve and refill the tank with water
8. Bring the solution to a simmer only, turn the thermostat off. Allow to stand for a few minutes.
9. Drain the tank according to DRAINING THE OIL procedure in this manual. Rinse thoroughly with clear, hot water. All traces of cleaner must be removed.
10. Close the drain valve and add shortening. Follow the FILLING TANK WITH SHORTENING procedure in this manual. The fryer is now ready for use.

MAINTENANCE

! WARNING

Hot oil and hot parts can cause burns. Use care when operating, cleaning, and servicing the fryer.

! WARNING

Spilling hot fryer compound can cause severe burns. Do not move fryer without draining all frying compound from the tank.

FLUE VENT INSPECTION

When the fryer is cool, inspect annually. Check the flue and clear any obstructions.

Troubleshooting Chart	
Problem:	Probable Cause:
No Heat	Thermostat dial not turned on. Pilot not lit. Gas supply not turned on. Wire connections loose (call service). Wire connections need cleaning (call service). Thermopile (call service).
Insufficient or too much heat	Thermostat dial not set to desired temperature. High limit tripped (call service). Temperature probe (call service).
Tank will not drain	Shortening too cold. Drain pipe clogged with debris.

TROUBLE SHOOTING

FOR AUTHORIZED SERVICE TECHNICIANS ONLY!



NOTICE

Warranty will be void and the manufacturer is relieved of all liability if:

(A) Service work is performed by other than a qualified technician (see warranty doc for details)

OR (B) Other than approved Avantco replacement parts are installed.



WARNING

Adjustments and service work may be performed only by a qualified technician who is experienced in, and knowledgeable with, the operation of commercial gas cooking equipment. However, to ensure your confidence, contact your Avantco Service Representative for reliable service, dependable advice or other assistance, and for genuine factory parts.

All units are adjusted at the factory. In case of problems in operation at initial installation, check type of gas and manifold pressure and compare with information listed on the serial plate.

A mill voltage circuit diagram is located inside the front door of the fryer, and also on page 19.

CHECKING AND ADJUSTING MAIN BURNERS

The main burners should burn with a steady blue flame, and the inner cone of the flame from each port should be about 3/4" long. The flame from each main burner should enter each heat tube without touching the front of the fry pot or the sides, top, or bottom of each tube.

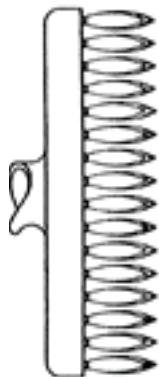

Yellow Tips
(too little air or too much gas)

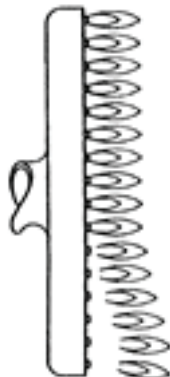

Blowing or Lifting Tips
(too much air)

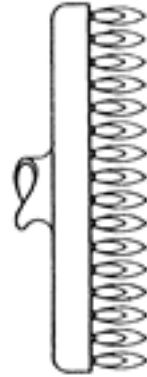

Normal Flame

Checking and adjusting pressure regulator

The combination gas valve (includes pressure regulator) is factory set at 4" W.C. for natural gas and 10" W.C. for liquid propane gas. To check the manifold pressure, do the following:

1. Turn thermostat "OFF" and combination gas valve knob to the "PILOT" setting.
2. Remove pressure tap plug from burner manifold located directly below the burners in the cabinet.
3. Install a fitting appropriate to connect a manometer.
4. Turn combination gas valve to "ON" position and thermostat to "ON." The burners will ignite. Be certain that sufficient oil is covering the tubes.
5. With burners on, read manometer.
6. If the manometer does not read 4" W.C. for natural gas, or 10" W.C. for propane gas, adjust regulator.
7. Remove regulator adjustment screw cap (see diagram on page 18).
8. With small screwdriver rotate adjustment screw "CLOCKWISE" to increase or "COUNTERCLOCKWISE" to decrease pressure. Be sure to adjust with burners "ON."
9. Turn thermostat "OFF" and set combination gas valve knob to "PILOT" position.
10. Remove manometer and replace pressure tap plug.
11. Replace adjustment screw cap.

Checking and adjusting calibration of thermostat

All thermostat controls are carefully calibrated at the factory (i.e., the dial is properly set to control appliance temperatures accurately). Only a qualified appliance service technician should perform this adjustment.

1. To check appliance temperatures, use a thermocouple-type temperature test instrument or reliable thermometer. Place the thermocouple of test instrument or thermometer in the center of the fry pot.
2. Turn the control dial to the temperature setting requiring the greatest accuracy. Allow enough time for temperature to stabilize, or until several temperature readings are identical.
3. Recalibrate if setting and actual temperature differ by more than 10°F.
4. Remove dial from dial shaft "B." Be careful that dial shaft does not rotate in either direction (which would change the dial setting).
5. Hold dial shaft "B" steady and with a screwdriver turn calibration screw "A" clockwise to decrease the temperature, or counterclockwise to increase the temperature.
6. Replace dial. Let the appliance operate until the temperature has stabilized before a final check is made to determine whether or not the calibration has been corrected.
7. Once correct, seal the calibration screw with glyptol.

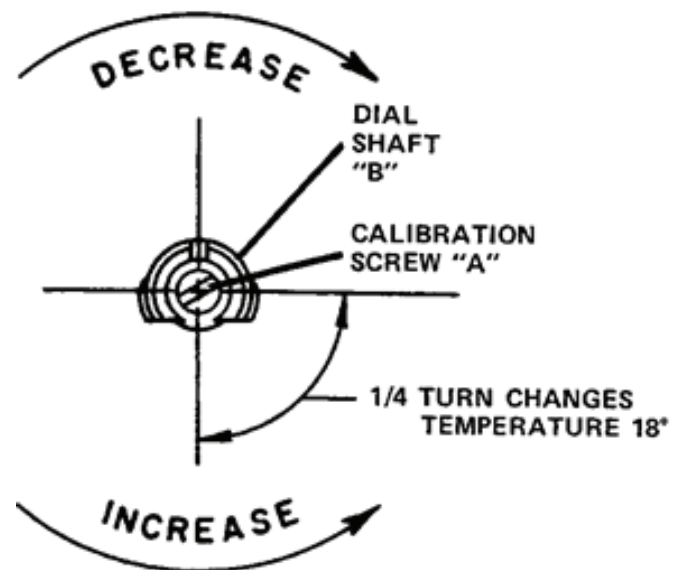

Checking and Adjusting Safety Pilot

The pilot flame should surround the thermopile for 1/2". It must be large and sharp enough to cause the thermopile to glow a dull red, or sufficient to hold the safety valve open.

1. Remove pilot adjustment cap.

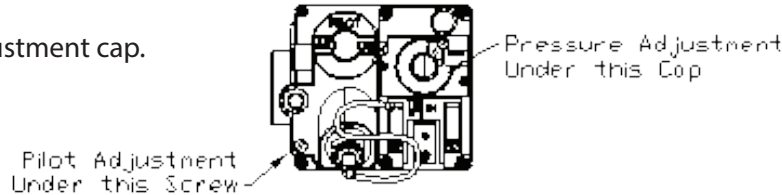

2. Adjust pilot key to provide properly sized flame as shown in diagram B. Diagram A shows improperly adjusted pilot.
3. Release pilot adjustment cap.



Problem

Likely Cause

Burners do not come on

Gas supply to unit off.
Combination gas valve is in "OFF" or "PILOT" position.
Pilot not ignited.
Thermostat is not "ON".

Pilot will not stay ignited

Combination gas valve is in "OFF" position.
Pilot gas not adjusted properly.
Gas supply to unit is off.
Bad thermopile.
Dirty thermopile connections at combination gas valve or high limit.
Clogged orifice.
Draft condition.
Air in gas line.
Improper ventilation system.

Pilot produces carbon deposits

Unit connected to wrong gas supply.
Pressure not adjusted correctly.
Pilot gas not adjusted correctly.

Burners produce carbon deposits

Wrong Size orifices.
Connected to wrong gas supply.
Pressure not adjusted correctly.
Flue obstruction.

NOTE

Vibrations or shock caused by shaking or pounding baskets on top surface or by slamming door may cause Hi-Limit Control Switch to open. If this condition persists, additional cushioning may be added to the rubber grommets supporting this control to absorb these shocks.

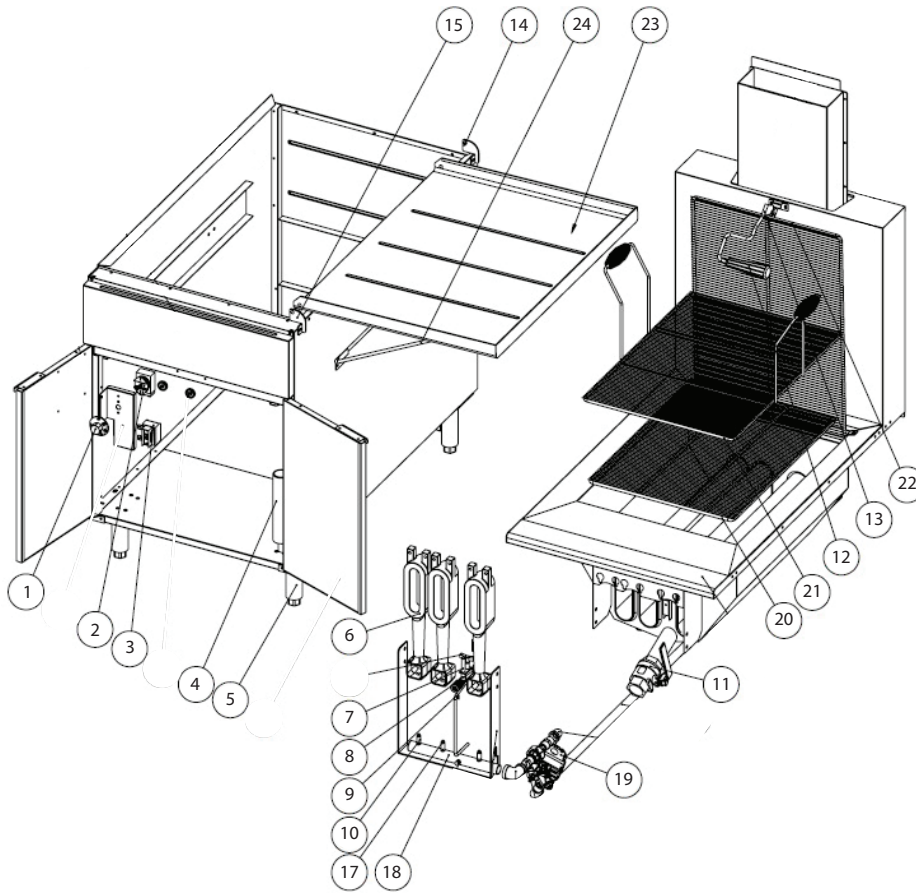

PART #	QTY	DESCRIPTION	KEY
177101103628	1	KNOB	1
177202200728	1	THERMOSTAT	2
177202200737	1	HIGH LIMIT	3
177202006273	1	DRAIN PIPE	4
177200900019	4	ADJUSTABLE LEG	5
177201301400	3-4	BURNER	6
177201700237	1	THERMOPILE	7
177026017029	1	PILOT BRACKET	8
177201900719	1	PILOT TUBING	9
177202006237	1	ORIFICE EXTENTION	10
177200500019	1	DRAIN VALVE	11
177200700664	1	BAKELITE HANDLE	12
177026080014	1	HANDLE	13
177026080011	1	BACK HINGE	14
17726080012	1	FRONT HINGE	15
177201302028	1	PILOT (NAT)	16a

PART #	QTY	DESCRIPTION	KEY
177201302019	1	PILOT (LP)	16b
177201500573	3-4	NOZZLE (NAT)	17a
177201500582	3-4	NOZZLE (LP)	17b
177201802646	1	MANIFOLD PIPE - FBF1824 FRYER	18a
17701807991L	1	MANIFOLD PIPE - FBF2424 FRYER	18b
177200500782	1	VALVE (LP)	19a
177200500773	1	VALVE (NAT)	19b
17701107755L	1	SCREEN - FBF1824 FRYER	20a
17701107728L	1	SCREEN - FBF2424 FRYER	20b
17701107764L	1	HANDLE W/SCREEN - FBF1824	21a
17701107737L	1	HANDLE W/SCREEN - FBF2424	21b
17701107773L	1	DONUT SCREEN - FBF1824	22a
17701107719L	1	DONUT SCREEN - FBF2424	22b
177026083008	1	COVER - FBF1824	23a
177026080010	1	COVER - FBF2424	23b
1771107782L	1	COVER SUPPORT - FBF1824	24a
1771107746L	1	COVER SUPPORT - FBF2424	24b