



Stainless Steel Vertical Hybrid Electric/Manual Sausage Stuffers

Models:

#177SS20V2 20 lb.

#177SS30V2 30 lb.

Warning:

Improper installation, adjustment, alteration, service, or maintenance can cause property damage, injury, or death. Read the installation, operating, and maintenance instructions thoroughly before installing or servicing this equipment.

For Your Safety:

Do not store or use gasoline or other flammable vapors or liquids in the vicinity of this or any other appliance.

Note:

Please read and keep these instructions. Indoor use only.

Table of Contents

Specifications	2
Safety Precautions	3
Assembly	4
Operation	6
Cleaning & Maintenance	7
Troubleshooting.....	8

Specifications

Vertical Stuffers

Model	177SS20V2	177SS30V2
Capacity	20 lb.	30 lb.
Width	16 ⁵ / ₁₆ "	16 ⁵ / ₁₆ "
Depth	12 ⁷ / ₁₆ "	12 ⁷ / ₁₆ "
Height	29 ¹⁵ / ₁₆ "	34 ³ / ₈ "
Funnels	5/8", 7/8", 1 1/4", 1 1/2"	

Stuffer Motor

Model	177SSV2MOTOR
Voltage	120V
Wattage	30W
Plug	NEMA 5-15P
Compatible Models	177SS20V, 177SS30V, 177SS20V2, 177SS30V2

Churro Tubes

Item #	177CMP1	177CMP2	177CMP3	177CMPH
Description	1 1/16" Non-Hollow Tube	1 5/16" Non-Hollow Tube	1" Non-Hollow Tube	Hollow Tube*

*Hollow tube must be used with all non-hollow tubes.

Safety Precautions



WARNING

- Read all instructions carefully and completely.
- For commercial use only.
- For indoor use only.
- ALWAYS check for damaged parts before using this stuffer. Check that parts are operating properly and performing the intended functions. Check for binding of moving parts, mounting, and any other conditions that may affect the operation.
- DO NOT operate this stuffer after it has malfunctioned or has been damaged in any way.
- ALWAYS check that the stuffer is on a sturdy and stable surface before use.
- ALWAYS unplug the power cord before cleaning.
- DO NOT use outdoors.
- DO NOT operate the stuffer with the gear housing cover open or removed.
- DO NOT operate the stuffer without proper eye protection. Safety glasses must conform to ANSI Z87.1 requirements (Z87 will be printed or stamped on them).
- DO NOT use unit for any application other than its intended use. Improper usage of the stuffer will void the warranty.
- Repairs must be done by an authorized dealer. Use only factory original parts and accessories. Modification of the stuffer will void the warranty.
- Avoid scratching the surface or nicking the edges of this unit.
- Children should be supervised to ensure that they DO NOT play with the unit.
- This appliance is not intended for use by persons (including children) with reduced physical, sensory, or mental capabilities, or lack of experience and knowledge, unless a person responsible for their safety has given them supervision or instruction concerning use of the appliance.

Save these instructions for future reference.

Assembly

Plunger Assembly

(Fig. 1)

1. Slide the plunger seal onto the plunger.
2. Assemble the pressure release valve kit onto the plunger.
 - a. From the top of the plunger, place the washer onto the valve hole.
 - b. From the underside of the plunger, place the spring onto the end of the valve cap.
 - c. Insert the top of the valve cap into the valve hole.
 - d. Secure in place with the screw top.
3. Place the assembled plunger onto the end of the plunger shaft.

Manual Stuffer Assembly

(Fig. 2)

1. Attach the handle by sliding it onto either the fast or the slow gear.
2. Crank the handle to bring the plunger to the top of the stuffer.
3. Rest the bottom brackets of the canister onto the canister mounts inside the housing of the stuffer.
4. Pivot the canister fully into the stuffer housing and snap the top brackets into the canister mounts.
5. Insert the stuffing or churro (Fig. 3) funnel of choice through the front ring nut. Screw the front ring nut and funnel onto the mouth of the canister until snug.

NOTE: DO NOT overtighten the front ring nut, as it may damage the funnel.
6. Thoroughly coat the inside of the canister with a food-grade lubricant prior to use.

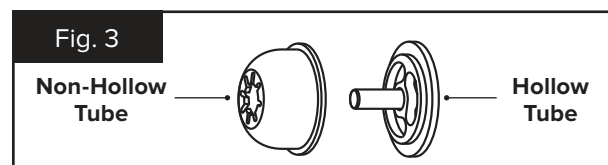
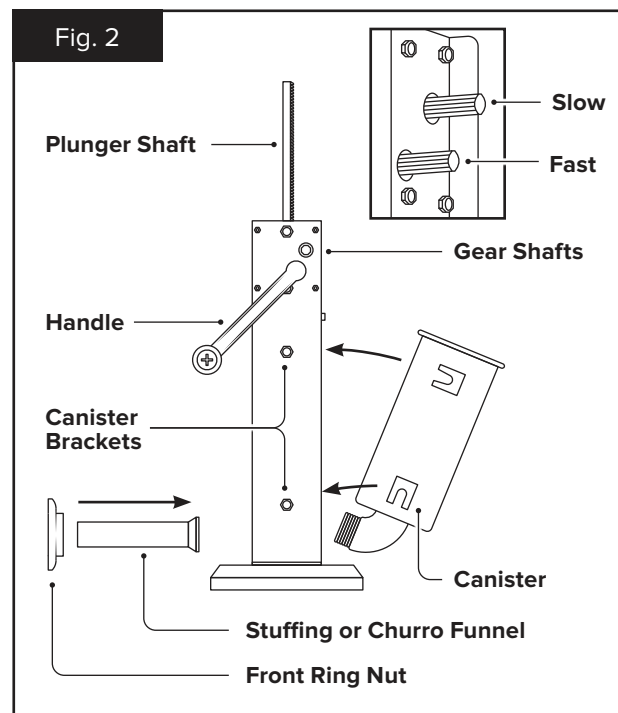
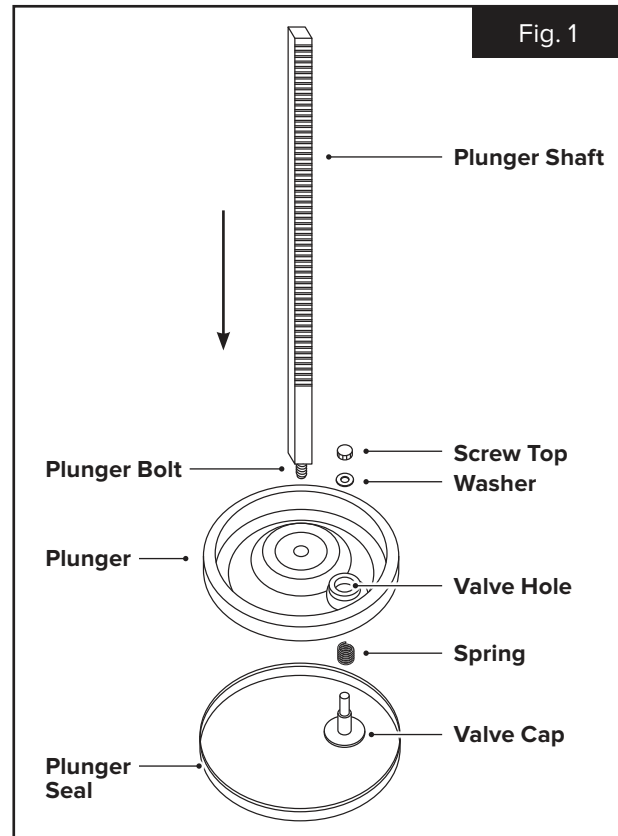

Assembly

Motor Assembly (#177SSV2MOTOR)

1. Use the handle to lower the plunger to approximately the halfway down position BEFORE installing the motor. (Fig. 4)
2. Remove the handle.
3. Insert the plug of the motor into the socket on the stuffer body. (Fig. 5)
4. Slide the motor onto the slow drive shaft, lining up the mounting thumbscrews to the mounting holes. (Fig. 5)
5. Screw the 3 thumbscrews into the mounting holes, alternating between them so the motor rests flat against the stuffer. (Fig. 5)
6. When parts are properly aligned, snugly tighten the 3 thumbscrews to secure the motor to the stuffer. (Fig. 5)

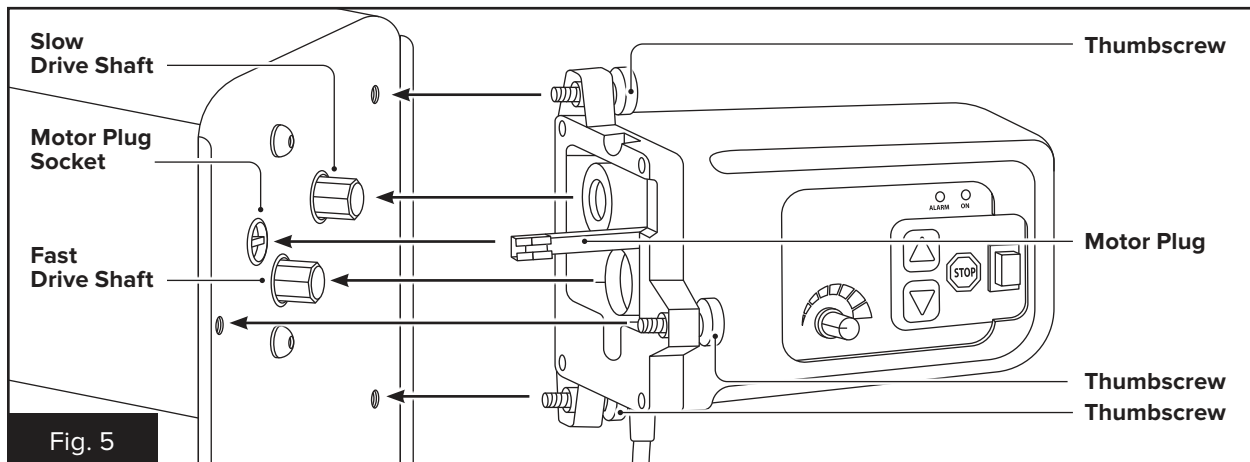
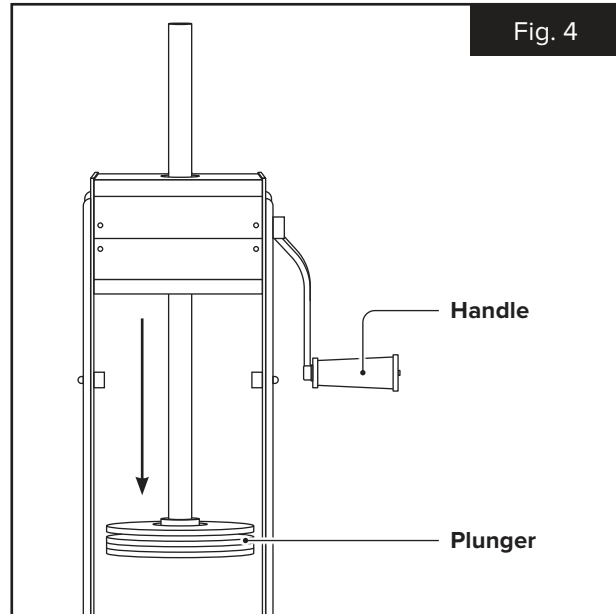

CAUTION

- The plug of the motor **MUST** be plugged into the socket entirely. If the plug is not securely inserted, the piston will not be able to stop at the cylinder bottom or the highest position automatically. This may cause the motor to overload or possibly damage the stuffer or motor. This type of damage is NOT covered under warranty.

Foot Pedal

(Fig. 6)

1. Install the motor onto the stuffer as detailed in the steps above.
2. With the unit disconnected from power, the foot pedal can be plugged into the underside of the motor.

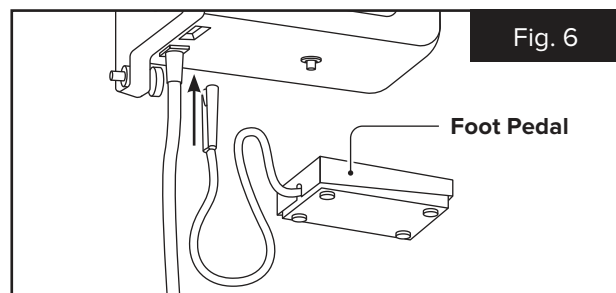

Operation

Motor Operated Stuffing

- **NOTE:** For thick mixtures, it is recommended to use the manual hand crank for best performance, as mixtures that are too thick can overwork the motor. To tell if the mixture is too thick, check whether the casing is filled unevenly. You might observe gaps or uneven distribution of the mixture within the casing.
1. With the motor securely attached to the stuffer, plug in the power cord.
 2. Press the POWER button to turn the motor on. The ON light will illuminate.
 3. Press the UP button to raise the piston. The unit will automatically stop at the highest position.
 4. Remove the cylinder from the base by tilting it off the top brackets, then lift off the lower brackets.
 5. Fill the cylinder and reinstall on mounting brackets.
 6. Press the DOWN button until the piston reaches the mixture, all the air pockets are removed, and the mixture is starting to be extruded to the end of the funnel.
 7. Press the STOP button.
 8. Place casing over the stuffing tube and twist, tie, or clip the end.
 9. You can now begin stuffing.
 - If using the control panel: Press DOWN button and use the speed dial to control the speed of the piston. Press the STOP button at any time to stop the piston from lowering.
 - If using the foot pedal: Depress the pedal and use the speed dial to control the speed of the piston. Release pressure on the pedal to stop the piston. Press the UP button while the piston is stopped to raise it up to the highest position.

NOTE: The UP, DOWN, and STOP buttons are inactive when depressing the foot pedal.
 10. The piston will continue to move down the stuffer until it reaches the bottom of the cylinder. At that time, it will stop for 3 seconds and then automatically rise to the highest position and stop.
 11. When finished, clean the unit immediately.

Alarm Reset

- If your mixture is too thick or there is an obstruction, the unit will shut off and the **ALARM** red light will turn on. In order to reset the sausage stuffer and clear the alarm, press the  button on the control panel. In order to prevent the **ALARM** from activating again, perform the following:
1. Clear any obstructions that may be present between the canister and the entry of the stuffing tube.
 2. Thin your meat mixture by removing it from the canister, adding cold water (or other desired liquid for thinning), and mixing in a separate bowl. We do not recommend thinning your meat mixture inside of the stuffing canister.
 3. Reduce the motor's speed using the control knob.

Manual Stuffing



CAUTION

- When the plunger is pulled out of the canister, **RELEASE THE HANDLE SLOWLY!** Pressure or gravity could cause the handle to spin back slightly and cause injury.

1. With the handle installed, tilt out the canister.
2. For sausage: Fill the canister with meat and seasoning mixture.
For churros: Fill the canister with churro dough. Ensure the volume ratio of water to flour is at least 1:1.
3. Press the mixture down into the canister firmly to release any trapped air.
4. Pivot the canister back into the upright position and snap the top brackets onto the canister mounts.
5. Turn the handle until the plunger comes in contact with the mixture and it is ready to extrude out of the end of the stuffing funnel.
6. Slip a casing on the end of the stuffing funnel until the entire casing has slid onto the funnel.
7. Tie, twist, or hog ring the end of the casing to seal it.
8. Turn the handle to extrude the mixture into the casing.
 - Fast gear shaft: Turn **CLOCKWISE** to raise the plunger, **COUNTERCLOCKWISE** to lower the plunger.
 - Slow gear shaft: Turn **COUNTERCLOCKWISE** to raise the plunger, **CLOCKWISE** to lower the plunger.**NOTE:** Only use the slow speed for churros.
9. For best results, apply pressure around the casing, close to the end of the stuffing funnel. This will hold the casing tight and will cause the mixture to pack firmly into the casing.
10. When the end of the casing has been reached, tie, twist, or hog ring the end of the casing to seal the contents inside.
11. When finished, clean the unit immediately.

Cleaning & Maintenance



CAUTION

- **ALWAYS** unplug the motor from the power source before cleaning.
 - **DO NOT** immerse **ANY** part of the motor in water or any other liquid.
 - **DO NOT** place the motor in the dishwasher.
 - **DO NOT** take the motor apart for any reason.
1. Remove the stuffing funnel by unscrewing the front ring nut and pulling the funnel out.
 2. Turn the handle until the plunger comes up and out of the canister.
 - Fast gear shaft: Turn **CLOCKWISE** to raise the plunger, **COUNTERCLOCKWISE** to lower the plunger.
 - Slow gear shaft: Turn **COUNTERCLOCKWISE** to raise the plunger, **CLOCKWISE** to lower the plunger.
 3. Pivot the canister outward, then pull the canister up to remove the canister from the stuffer housing.
 4. Unscrew the plunger from the plunger shaft.
 5. Disassemble the pressure release valve from the plunger.
 6. Remove the plunger seal from the plunger.
 7. Wash all parts that have come in contact with meat in hot water with a mild detergent.
 8. Clean the outside of the motor with a damp cloth and dry thoroughly.
 9. Rinse and thoroughly dry all parts immediately.
 10. Sanitize as needed.
 11. Fully lubricate the shaft, canister, pressure-release valve components, and the front ring nut with a food-grade lubricant before and after each use.
NOTE: The motor is permanently lubricated.

Troubleshooting

Issue	Possible Cause	Solution
Stuffer is hard to crank.	Meat mixture has become too stiff.	Add water/oil to the mix.
	Piston gasket is sticking.	Add lubricant (mineral or vegetable oil) to the piston gasket and the interior of the cylinder.
Meat is passing by the piston.	Gasket is not installed.	Follow assembly instructions. (Page 4)
	Gasket is not lubricated.	Lubricate the gasket.
Casings are bursting when filling.	Casings are old and brittle.	Follow instructions carefully for the casings you are using.
	Casings were not soaked long enough.	
	Casings were soaked too long.	
	Casings should not have been soaked.	
	Casings were filled too tightly.	Adjust the speed of the piston to fill slower and allow the casing to move more freely while filling.
	Stuffing tube has a burr and is puncturing the casing.	Replace stuffing tube.
Motor not turning on.	Stuffing tube is too large for casings.	Choose a smaller size stuffing tube.
	Circuit breaker tripped.	Reset the circuit breaker by pressing the power switch to the OFF position. Then press the reset button on the underside of the motor. Press the power switch to the ON position, the light should illuminate.
	If stuffer has been operated for longer than 20 minutes at a time, the overheat protection may have been activated.	Turn power switch OFF and allow unit to cool for 15 minutes.