

Installation Guide

Avigilon H5A Box Camera Models:

2.0C-H5A-B1

2.0C-H5A-B2

2.0C-H5A-B3

4.0C-H5A-B2

4.0C-H5A-B3

6.0C-H5A-B2

8.0C-H5A-B2

Legal Notices

© 2023, Avigilon Corporation. All rights reserved. AVIGILON, the AVIGILON logo, AVIGILON CONTROL CENTER, and ACC are trademarks of Avigilon Corporation. Other names or logos mentioned herein may be the trademarks of their respective owners. The absence of the symbols ™ and ® in proximity to each trademark in this document or at all is not a disclaimer of ownership of the related trademark.

Disclaimer

This document has been compiled and published using product descriptions and specifications available at the time of publication. The contents of this document and the specifications of the products discussed herein are subject to change without notice. Avigilon Corporation reserves the right to make any such changes without notice. Neither Avigilon Corporation nor any of its affiliated companies: (1) guarantees the completeness or accuracy of the information contained in this document; or (2) is responsible for your use of, or reliance on, the information. Avigilon Corporation shall not be responsible for any losses or damages (including consequential damages) caused by reliance on the information presented herein.

Avigilon Corporation
avigilon.com

PDF-H5A-B-A

Revision: 4 - EN

20230609

Important Safety Information

This manual provides installation and operation information and precautions for the use of this device. Incorrect installation could cause an unexpected fault. Before installing this equipment read this manual carefully. Please provide this manual to the owner of the equipment for future reference.



This Warning symbol indicates the presence of dangerous voltage within and outside the product enclosure that may result in a risk of electric shock, serious injury or death to persons if proper precautions are not followed.



This Caution symbol alerts the user to the presence of hazards that may cause minor or moderate injury to persons, damage to property or damage to the product itself if proper precautions are not followed.



WARNING — Failure to observe the following instructions may result in severe injury or death.

- Do not use near water or expose to dripping or splashing.
- Do not place objects filled with liquids above the device.
- Do not expose to rain or moisture.
- For indoor use only.
- Installation must be performed by qualified personnel only, and must conform to all local codes.
- This product is intended to be supplied by a UL Listed Power Unit marked “Class 2” or “LPS” or “Limited Power Source” with output rated 12 VDC or 24 VAC, 7 W min. or Power over Ethernet (PoE), rated 48 VDC, 7 W min.
- Any external power supply connected to this product may only be connected to another Avigilon product of the same model series. External power connections must be properly insulated.
- Do not connect directly to mains power for any reason.



CAUTION — Failure to observe the following instructions may result in injury to persons or damage to the device.

- Do not install near any heat sources such as radiators, heat registers, stoves, or other sources of heat.
- Do not subject the device cables to excessive stress, heavy loads or pinching.
- Do not open or disassemble the device. There are no user serviceable parts.
- Refer all device servicing to qualified personnel. Servicing may be required when the device has been damaged (such as from a liquid spill or fallen objects), has been exposed to rain or moisture, does not operate normally, or has been dropped.
- Do not use strong or abrasive detergents when cleaning the device body.
- Use only accessories recommended by Avigilon.
- Do not expose the camera directly to high levels of x-ray, laser, or UV radiation. Direct exposure may

cause permanent damage to the image sensor.

- Use only UL-listed mounting bracket suitable for the mounting surface and minimum 0.7 kg (1.6 lb) weight.
- Use of controls or adjustments or performance of procedures other than those specified in this document may result in hazardous radiation exposure.
- If used outdoors, an approved outdoor mounting adapter or enclosure is required. Consult with Avigilon for more information.

Regulatory Notices

This device complies with part 15 of the FCC Rules. Operation is subject to the following two conditions: (1) this device may not cause harmful interference, and (2) this device must accept any interference received, including interference that may cause undesired operation.

This Class B digital apparatus complies with Canadian ICES-003.

This equipment has been tested and found to comply with the limits for a Class B digital device, pursuant to Part 15 of the FCC rules. These limits are designed to provide reasonable protection against harmful interference in a residential installation. This equipment generates, uses and can radiate radio frequency energy and, if not installed and used in accordance with the instructions, may cause harmful interference to radio communications. However, there is no guarantee that interference will not occur in a particular installation. If this equipment does cause harmful interference to radio or television reception, which can be determined by turning the equipment off and on, the user is encouraged to try to correct the interference by one or more of the following measures:

- Reorient or relocate the receiving antenna.
- Increase the separation between the equipment and the receiver.
- Connect the equipment into an outlet on a circuit different from that to which the receiver is connected.
- Consult the dealer or an experienced radio/TV technician for help.

Changes or modifications made to this equipment not expressly approved by Avigilon Corporation or parties authorized by Avigilon Corporation could void the user's authority to operate this equipment.

For Korea

이 기기는 가정용(B급) 전자파적합기기로서 주로 가정에서 사용하는 것을 목적으로 하며, 모든 지역에서 사용할 수 있습니다.

Disposal and Recycling Information

When this product has reached the end of its useful life, please dispose of it according to your local environmental laws and guidelines.

Risk of fire, explosion, and burns. Do not disassemble, crush, heat above 100 °C (212 °F), or incinerate.

European Union:



This symbol means that according to local laws and regulations your product should be disposed of separately from household waste. When this product reaches its end of life, take it to a collection point

designated by local authorities. Some collection points accept products for free. The separate collection and recycling of your product at the time of disposal will help conserve natural resources and ensure that it is recycled in a manner that protects human health and the environment.

Table of Contents

Overview	1
Front View	1
Rear View	2
Installation	3
Required Tools and Materials	3
Camera Package Contents	3
Installation Steps	3
Mounting the Camera	3
Connecting Cables	3
Initializing a Camera Username and Password	4
(Optional) Using the USB Wi-Fi Adapter	5
Assigning an IP Address	5
Accessing the Live Video Stream	6
Aiming and Focusing the Camera	6
(Optional) Configuring SD Card Storage	7
Configuring the Camera	7
For More Information	7
Cable Connections	8
Connecting External Power	8
Non-Seamless Failover	8
Connecting to External Devices	8
Connecting to Microphones, Speakers, and Video Monitors	9
Connection Status LED Indicator	11
Troubleshooting Network Connections and LED Behavior	11
Resetting to Factory Default Settings	13
Setting the IP Address Using the ARP/Ping Method	14
Limited Warranty and Technical Support	15

Overview

Front View

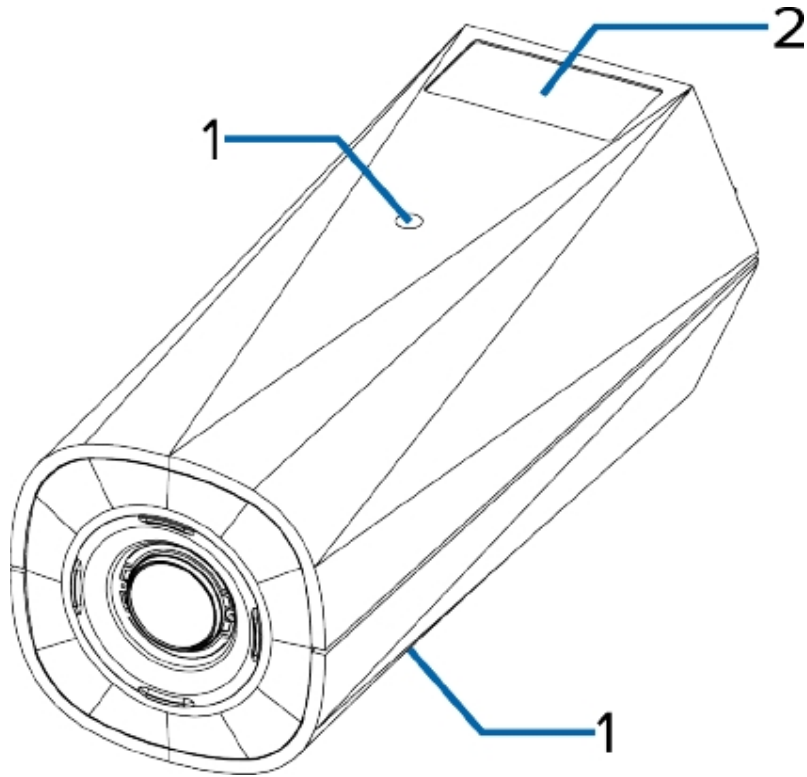

1. **Camera mounts**

Provides mounting points for the camera. Mounts accept 1/4"-20 x 5/16" max thread UNC bolts commonly found on tripods and mounting brackets.

2. **Serial number tag**

Device information, product serial number and part number label.

Rear View

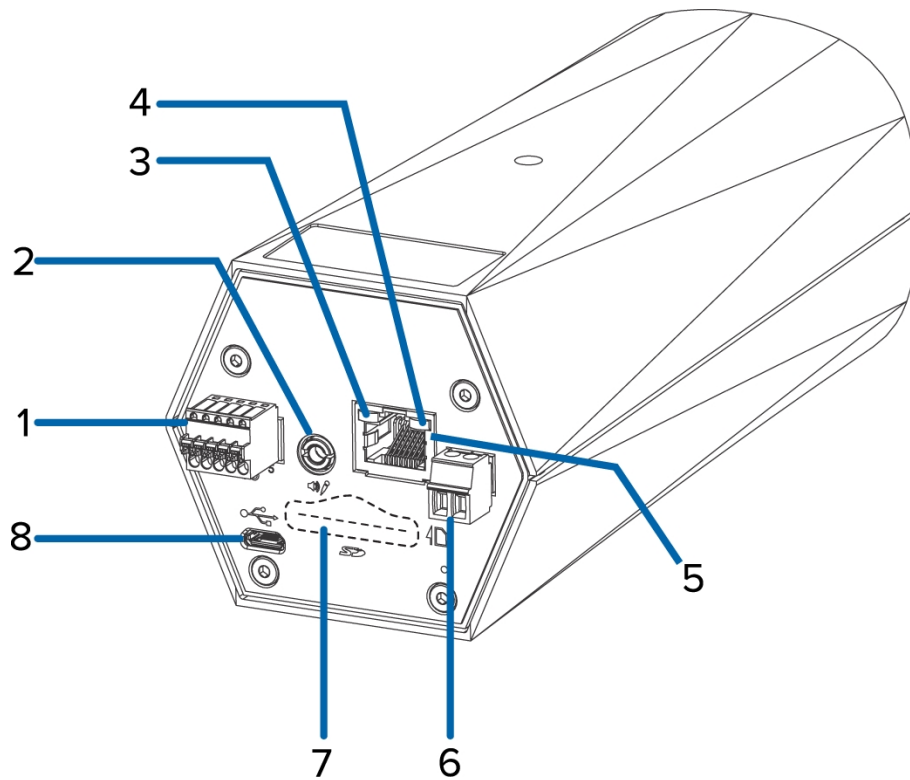

- 1. I/O connector block**
Provides connections to external input/output devices.
- 2. Audio/video connector**
Accepts a mini-jack connector (3.5 mm).
- 3. Connection status LED indicator**
Green LED provides information about device operation. For more information, see *Connection Status LED Indicator* on page 11.
- 4. Link LED indicator**
Amber LED indicates if there is an active connection in the Ethernet port.
- 5. Ethernet port**
Accepts an Ethernet connection to a network. Server communication and image data transmission occurs over this connection. Also receives power when it is connected to a network that provides Power over Ethernet.
- 6. Power connector block**
Accepts a terminal block with either an AC or DC power connection. DC input can be either polarity. Only required when Power over Ethernet is not available.
- 7. SD card slot**
Accepts an SD card for onboard storage.
- 8. Micro USB port**
Accepts a micro USB to USB adapter. Only required when using the Avigilon USB Wi-Fi Adapter.

Installation

Required Tools and Materials

- Small slotted screwdriver with 5/64" or 2 mm blade width — for connecting power when not using Power over Ethernet.
- Mounting bracket, enclosure or tripod.

Camera Package Contents

- Avigilon H5A IP Box Camera

Installation Steps

Complete the following sections to install the device.

Mounting the Camera

Camera mounting points are provided on both the top and bottom of the camera body. Use these mounting points to mount the camera on a bracket, in an enclosure, or on a tripod. The mounting points have ¼"-20 UNC threaded holes which allow them to accept standard photographic mounting bolts.

Consult the installation instructions provided with the bracket, enclosure or tripod for detailed mounting instructions.



WARNING — Use only UL-listed mounting bracket suitable for the mounting surface and minimum 0.7 kg (1.6 lb) weight.

Connecting Cables

Refer to the diagrams in the Overview section for the location of the different connectors.

To connect the cables required for proper operation, complete the following:

1. If external input or output devices are part of the installation (for example: door contacts, relays, etc.), connect the devices to the I/O connector block.
2. If an external microphone needs to be connected to the camera, connect the device to the camera A/V connector.
For more information see *Connecting to Microphones, Speakers, and Video Monitors* on page 9.
3. (2.0 megapixel models only) If an external video monitor needs to be connected to the camera, connect the device to the camera A/V Connector.

For more information see *Connecting to Microphones, Speakers, and Video Monitors* on page 9.

4. Connect power using one of the following methods:
 - Power over Ethernet (PoE) Class 3 — If PoE is available, the LEDs will turn on.
 - External Power — Connect an external 12 V DC or 24 V AC power source to the power connector block.
5. Connect a network cable to the Ethernet port (RJ-45 connector).

The Link LED indicator will turn on once a network link has been established.
6. Check that the Connection Status LED indicator indicates the correct state. For more information, see *Connection Status LED Indicator* on page 11.

Initializing a Camera Username and Password

Cameras manufactured after January 1, 2020, do not have a default username or password and will be in a factory default state.

Important: You must create a user with *administrator* privileges before the camera is operational.

The first user can be created using any of the following methods:

- Camera's Web Interface: enter the camera's IP address in a web browser to access the web interface. If the camera is in the factory default state you will be redirected to the Add a new user page to create the first user. For more information, see the *Avigilon High Definition H4 and H5 IP Camera Web Interface User Guide*.
- Camera Configuration Tool: cameras discovered in the factory default state will be identified by . Select the **Admin Users** tab to create the first user. For more information, see the *Avigilon Camera Configuration Tool User Guide*.
- USB Wi-Fi Adapter: when connecting a camera in the factory default state, you will be redirected to the Create Administrator User page to create the first user. For more information, see *Motorola Solutions USB Wi-Fi Adapter System User Guide*.
- Avigilon Control Center software version 7.4 or later, or version 6.14.12 or later: when connecting a camera in the factory default state, the client software will ask you to create a new user. For more information, see the *Avigilon Control Center Client User Guide*.
- Avigilon Cloud Services (ACS) v3.0 or later: when adding a camera you will be asked to create a new user for cameras in the factory default state. For more information, see the *Avigilon Cloud Services User Guide*.

Tip: If you are connecting your Avigilon camera to a 3rd party VMS, you will need to set up the first user through the camera's Web Interface, USB Wifi Adapter, or Camera Configuration Tool before you connect to the 3rd party VMS.

(Optional) Using the USB Wi-Fi Adapter

If you have a USB Wi-Fi Adapter (H4-AC-WIFI), attach it to the camera's micro USB port to access the camera's mobile web interface.

After you connect to the Wi-Fi signal broadcast by the adapter, you can access the mobile web interface from any mobile device using the following address:

`http://camera.lan`

For more information about configuring the camera from the mobile web interface see *Avigilon USB Wi-Fi Adapter System User Guide*.

Note: The camera will reserve the 10.11.22.32/28 subnet for internal use while the USB Wi-Fi Adapter is plugged in.

Assigning an IP Address

The device automatically obtains an IP address when it is connected to a network.

Note: If the device cannot obtain an IP address from a DHCP server, it will use Zero Configuration Networking (Zeroconf) to choose an IP address. When set using Zeroconf, the IP address is in the 169.254.0.0/16 subnet.

The IP address settings can be changed using one of the following methods:

- The mobile web interface using the USB Wifi Adapter. For more information, see *(Optional) Using the USB Wi-Fi Adapter* above.
- Device's web browser interface: `http://<camera IP address>/`.
- Network Video Management software application (for example, the Avigilon Control Center™ software).
- ARP/Ping method. For more information, see *Setting the IP Address Using the ARP/Ping Method* on page 14.

Note:

Depending on the manufacture date of your camera, you will have one of the two options below to log in for the first time:

- Cameras manufactured after January 1, 2020: these cameras do not have a default username or password and will be in a factory default state. **You must create a user with administrator privileges before the camera is operational.** For more information, see *Initializing a Camera Username and Password* on page 4.
- Cameras manufactured before January 1, 2020: login to the camera using the default username of `administrator` with no password. It is recommended that you change the password after your first login.

Accessing the Live Video Stream

Live video stream can be viewed using one of the following methods:

- The mobile web interface using the USB Wifi Adapter. For more information, see *(Optional) Using the USB Wi-Fi Adapter* on the previous page.
- Web browser interface: `http://< camera IP address>/`.
- Network Video Management software application (for example, the Avigilon Control Center software).

Note:

Depending on the manufacture date of your camera, you will have one of the two options below to log in for the first time:

- Cameras manufactured after January 1, 2020: these cameras do not have a default username or password and will be in a factory default state. **You must create a user with administrator privileges before the camera is operational.** For more information, see *Initializing a Camera Username and Password* on page 4.
- Cameras manufactured before January 1, 2020: login to the camera using the default username of `administrator` with no password. It is recommended that you change the password after your first login.

Aiming and Focusing the Camera

Use the camera web browser interface or the Avigilon Control Center software to aim and focus the camera. Consult the software user guide for more information.

1. In the Image and Display settings area, use the Zoom controls to set the zoom position for the camera.
2. Focus the camera:
 - a. Click **Auto Focus** to focus the lens.
 - b. If the preferred focus was not achieved, use the focus near and far buttons to adjust the focus.

(Optional) Configuring SD Card Storage

To use the camera's SD card storage feature, you must insert an SD card into the card slot.

It is recommended that the SD card have a capacity of 8 GB or more and a write speed of class 10 or better. If the SD card does not meet the recommended capacity or write speed, the recording performance may suffer and result in the loss of frames or footage.

1. Insert an SD card into the camera.



CAUTION — Do not force the SD card into the camera or you may damage the card and the camera. The SD card can only be inserted in one direction.

2. Access the camera's web interface to enable the onboard storage feature. For more information, see the *Avigilon High Definition H4 and H5 IP Camera Web Interface User Guide*.

Configuring the Camera

Once installed, use one of the following methods to configure the camera:

- If you have the USB Wifi Adapter, you can access the mobile web interface to configure the camera. For more information, see *Avigilon USB Wi-Fi Adapter System User Guide*.
- If you have installed multiple cameras, you can use the Camera Configuration Tool to configure common settings. For more information, see the *Camera Configuration Tool User Guide*.
- If the camera is connected to the Avigilon Control Center system, you can use the client software to configure the camera. For more information, see the *Avigilon Control Center Client User Guide*.
- If the camera is connected to a third-party network management system, you can configure the camera's specialty features in the camera's web browser interface. For more information, see the *Avigilon High Definition H4 and H5 IP Camera Web Interface User Guide*.

For More Information

Additional information about setting up and using the device is available in the following guides:

- *Avigilon Control Center Client User Guide*
- *Web Interface User Guide* — Avigilon Presence Detector™ Device
- *Web Interface User Guide* — Avigilon High Definition H4 and H5 IP Cameras
- *Web Interface User Guide* — Avigilon High Definition H4 and H5 IP Cameras
- *Avigilon USB Wi-Fi Adapter System User Guide*
- *Avigilon Camera Configuration Tool User Guide*
- *Designing a Site with Avigilon Video Analytics*

These guides are available on help.avigilon.com and on the Avigilon website: avigilon.com/support.

Cable Connections

Connecting External Power

If PoE is not available, the camera needs to be powered through the removable power connector block. Refer to the diagrams in this guide for the location of the power connector block.

The power consumption information is listed in the product specifications.

To connect power to the power connector block, complete the following steps:

1. Remove the power connector block from the camera.
2. Remove the insulation from ¼" (6 mm) of the power wires. Do not nick or damage the wires.
3. Insert the two power wires into the two terminals on the power connector block. The connection can be made with either polarity.
Use a small slotted (5/64" or 2 mm blade width) screwdriver to loosen and tighten the terminals.
4. Attach the power connector block back into the camera.



WARNING — This product is intended to be supplied by a UL Listed Power Unit marked “Class 2” or “LPS” or “Limited Power Source” with output rated 12 VDC or 24 VAC, 8 W min. or PoE rated 48 VDC, 7 W min.

Non-Seamless Failover

- If the camera has power available from both an external Aux power supply and a PoE PSE (Power Sourcing Equipment) device, the camera will draw power from Aux.
- When the camera is using Aux power, PoE power negotiation is inhibited.
- If the camera loses Aux power, the camera will power-off while waiting to transition to PoE power.
- If the external Aux power re-energizes, the camera might reboot while transitioning back to using Aux power. The camera might not reboot if the external Aux power supply reacts quickly enough to the increase in load.
- Ensure that sufficient power is manually reserved on the PSE, as the camera will not request PoE power until the camera loses Aux power.

Connecting to External Devices

External devices are connected to the camera through the I/O terminal block. The pinout for the I/O terminal block is shown in the following diagram:

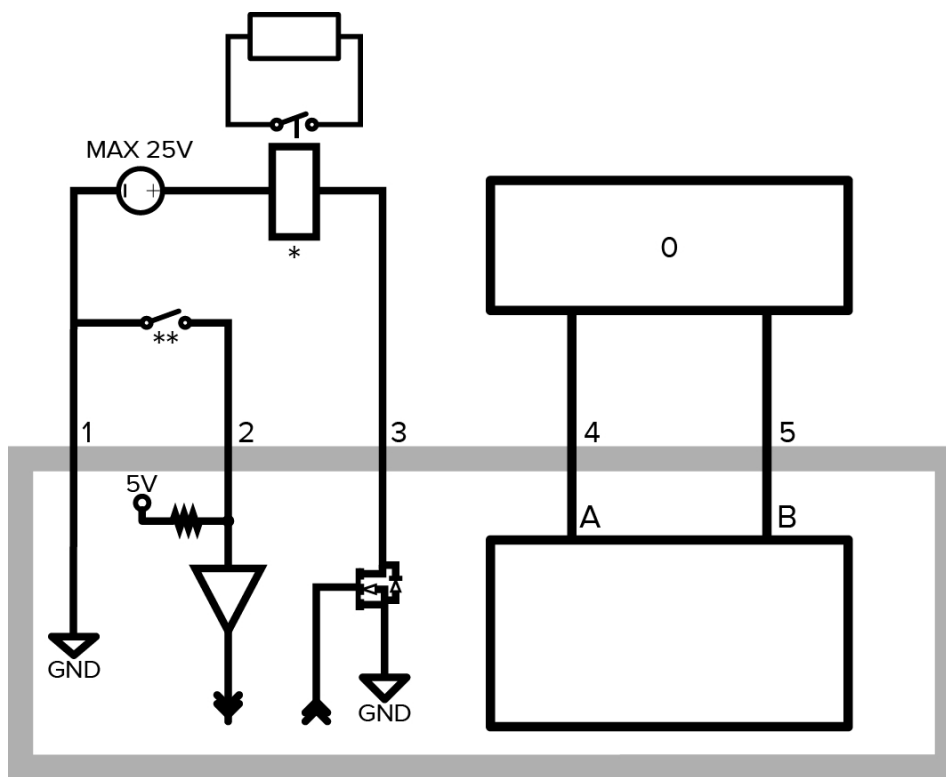

Figure 1: Example application.

1. Ground
 2. Relay Input — To activate, connect the Input to the Ground pin. To deactivate, leave disconnected or apply between 3-15 V.
 3. Relay Output — When active, Output is internally connected with the Ground pin. Circuit is open when inactive. Maximum load is 25 VDC, 120 mA.
 4. RS-485 A — Non-inverting RS-485 pin for controlling external equipment.
 5. RS-485 B — Inverting RS-485 pin for controlling external equipment.
- 0 — External Device
 - * — Relay
 - ** — Switch

Connecting to Microphones, Speakers, and Video Monitors

The camera can be connected to an external microphone, speaker and video monitor through the mini-jack (3.5 mm) audio/video connector (Avigilon part number CM-AC-AVIO1).

Only the 2.0 megapixel models can be connected to an external video monitor through the A/V connector.

Note: The camera only supports line level mono audio input and an NTSC or PAL video output.

The video output signal is determined by the camera flicker control setting. When the camera flicker control is set to 60 Hz, the video output signal is NTSC. When the flicker control is set to 50 Hz, the video output signal is PAL. Use the Camera Installation Tool to configure the camera's flicker control in the Image and Display setup.

The pinout for the connector is shown in the following diagram:

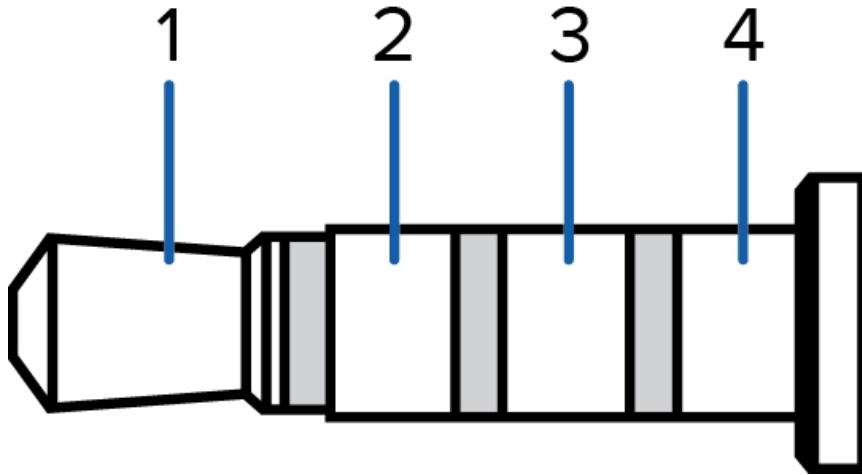

The wiring for the connector pinout is shown in the following table:

Ring	Purpose	Wire
1	Audio IN	Red
2	Composite Video OUT	Black
3	GND	Yellow
4	Audio OUT	Green
4	No connection	Green

Connection Status LED Indicator

Once connected to the network, the green Connection Status LED indicator will display the progress in connecting to the Network Video Management software.

The following table describes what the LED indicator shows:

Connection State	Connection Status LED Indicator	Description
Obtaining IP Address	One short flash every second	Attempting to obtain an IP address.
Discoverable	Two short flashes every second	Obtained an IP address but not connected to the Network Video Management software.
Upgrading Firmware	Two short flashes and one long flash every second	Updating the firmware.
Connected	On	Connected to the Network Video Management software or an ACC™ Server. The default connected setting can be changed to Off using the camera's web user interface. For more information see the <i>Avigilon High Definition H4 and H5 IP Camera Web Interface User Guide</i> .

Troubleshooting Network Connections and LED Behavior

Note: For any of the below LED behaviors, ensure that the camera is getting power and is using a good network cable before trying another solution.

LED Behavior	Suggested Solution
Green LED is off and amber is on	Perform a factory reset of the camera using the physical firmware revert button. Resetting through the camera's web interface will not produce the desired result.
Both LEDs are off and the camera is not connected or streaming video	Check the General setup page in the camera's web interface to ensure the LEDs are not disabled. If the LEDs are not disabled, perform a factory reset of the camera using the physical firmware revert button. Resetting through the camera's web interface will not produce the desired result.

LED Behavior	Suggested Solution
Both LEDs are blinking several times at the same time, then pause and repeat the blinking	Perform a factory reset of the camera using the physical firmware revert button. Resetting through the camera's web interface will not produce the desired result.
A different LED blinking pattern than those described above	Perform a factory reset of the camera using the physical firmware revert button. Resetting through the camera's web interface will not produce the desired result.

Resetting to Factory Default Settings

If the device no longer functions as expected, you can choose to reset the device to its factory default settings.

Use the firmware revert button to reset the device. The firmware revert button is shown in the following diagram:

For models that feature an SD card slot, resetting the camera will not affect video that has been recorded to the SD card.

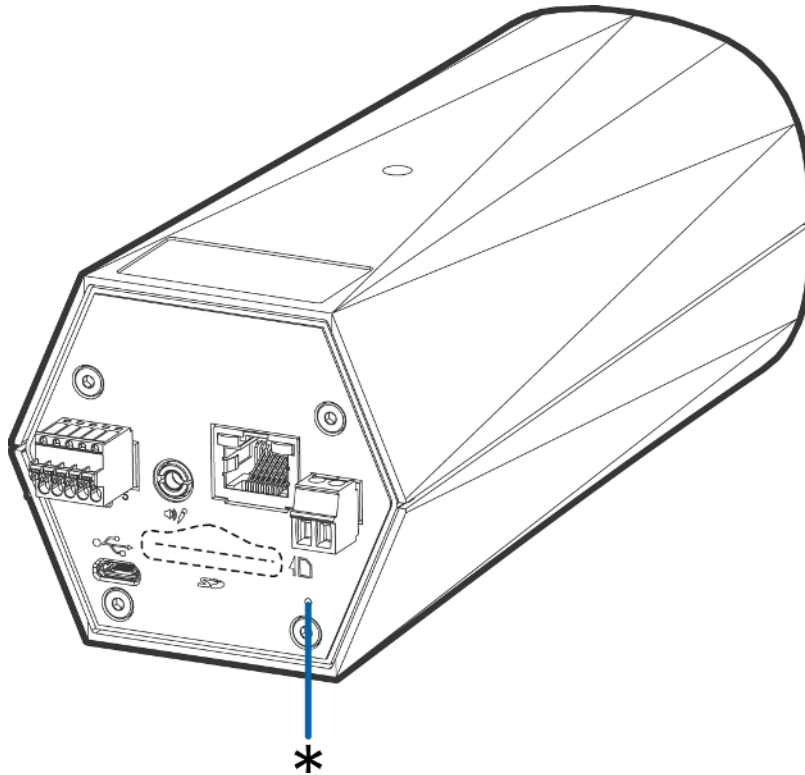

Figure 2: The firmware revert button on the rear of the camera

1. Ensure the device is powered on.
2. Using a straightened paperclip or similar tool, gently press and hold the firmware revert button.
3. Release the button after three seconds.



CAUTION — Do not apply excessive force. Inserting the tool too far may damage the camera.

Setting the IP Address Using the ARP/Ping Method

Complete the following steps to configure the camera to use a specific IP address:

Note: The ARP/Ping Method will not work if the **Disable setting static IP address through ARP/Ping method** checkbox is selected in the camera's device's web browser interface. For more information, see the *Avigilon High Definition H4 and H5 IP Camera APD Sensor Web Interface User Guide*.

1. Locate and make note of the MAC Address (MAC) listed on the Serial Number Tag for reference.
2. Open a Command Prompt window and enter the following commands:
 - a. `arp -s <New CameraDevice IP Address> <CameraDevice MAC Address>`
For example: `arp -s 192.168.1.10 00-18-85-12-45-78`
 - b. `ping -l 123 -t <New CameraDevice IP Address>`
For example: `ping -l 123 -t 192.168.1.10`
3. Reboot the camera device.
4. Close the Command Prompt window when you see the following message:
Reply from <New CameraDevice IP Address>: ...

Limited Warranty and Technical Support

Avigilon warranty terms for this product are provided at [avigilon.com/warranty](https://www.avigilon.com/warranty).

Warranty service and technical support can be obtained by contacting Avigilon Technical Support: [avigilon.com/contact](https://www.avigilon.com/contact).