

Owner's Manual & Safety Instructions

Save This Manual Keep this manual for the safety warnings and precautions, assembly, operating, inspection, maintenance and cleaning procedures. Write the product's serial number in the back of the manual (or month and year of purchase if product has no number). Keep this manual and the receipt in a safe and dry place for future reference.

23e

BauerTM

21107E-B

12" DISC SANDER



Visit our website at: <http://www.harborfreight.com>
Email our technical support at: productsupport@harborfreight.com

58862

When unpacking, make sure that the product is intact and undamaged. If any parts are missing or broken, please call 1-888-866-5797 as soon as possible.

Copyright© 2023 by Harbor Freight Tools®. All rights reserved.
No portion of this manual or any artwork contained herein may be reproduced in any shape or form without the express written consent of Harbor Freight Tools. Diagrams within this manual may not be drawn proportionally. Due to continuing improvements, actual product may differ slightly from the product described herein.
Tools required for assembly and service may not be included.

⚠ WARNING

Read this material before using this product.
Failure to do so can result in serious injury.
SAVE THIS MANUAL.

Table of Contents

Safety	2	Maintenance	12
Specifications	7	Parts List and Diagram	14
Setup	7	Warranty	16
Operation	2		

SAFETY



SETUP

OPERATION

MAINTENANCE

WARNING SYMBOLS AND DEFINITIONS

	This is the safety alert symbol. It is used to alert you to potential personal injury hazards. Obey all safety messages that follow this symbol to avoid possible injury or death.
	Indicates a hazardous situation which, if not avoided, will result in death or serious injury.
	Indicates a hazardous situation which, if not avoided, could result in death or serious injury.
	Indicates a hazardous situation which, if not avoided, could result in minor or moderate injury.
	Addresses practices not related to personal injury.

IMPORTANT SAFETY INFORMATION

General Tool Safety Warnings

WARNING

Read all safety warnings and instructions.

Failure to follow the warnings and instructions may result in electric shock, fire and/or serious injury.

Save all warnings and instructions for future reference.

- KEEP GUARDS IN PLACE and in working order.
- REMOVE ADJUSTING KEYS AND WRENCHES. Form habit of checking to see that keys and adjusting wrenches are removed from tool before turning it on.
- KEEP WORK AREA CLEAN. Cluttered areas and benches invite accidents.
- DON'T USE IN DANGEROUS ENVIRONMENT. Don't use power tools in damp or wet locations, or expose them to rain. Keep work area well lighted.
- KEEP CHILDREN AWAY. All visitors should be kept safe distance from work area.
- MAKE WORKSHOP KID PROOF with padlocks, master switches, or by removing starter keys.
- DON'T FORCE TOOL. It will do the job better and safer at the rate for which it was designed.
- USE RIGHT TOOL. Don't force tool or attachment to do a job for which it was not designed.

Table A: RECOMMENDED MINIMUM WIRE GAUGE FOR EXTENSION CORDS (120 VOLT)

NAMEPLATE AMPERES (at full load)	EXTENSION CORD LENGTH			
	25'	50'	100'	150'
0 – 6	18	16	16	14
6.1 – 10	18	16	14	12
10.1 – 12	16	16	14	12
12.1 – 16	14	12	Do not use.	

9. **USE PROPER EXTENSION CORD.** Make sure your extension cord is in good condition. When using an extension cord, be sure to use one heavy enough to carry the current your product will draw. An undersized cord will cause a drop in line voltage resulting in loss of power and overheating. Table A shows the correct size to use depending on cord length and nameplate ampere rating. If in doubt, use the next heavier gauge. The smaller the gauge number, the heavier the cord.
10. **WEAR PROPER APPAREL.** Do not wear loose clothing, gloves, neckties, rings, bracelets, or other jewelry which may get caught in moving parts. Nonslip footwear is recommended. Wear protective hair covering to contain long hair.
11. **ALWAYS USE SAFETY GLASSES.** Also use face or dust mask if cutting operation is dusty. Everyday eyeglasses only have impact resistant lenses, they are NOT safety glasses.
12. **SECURE WORK.** Use clamps or a vise to hold work when practical. It's safer than using your hand and it frees both hands to operate tool.
13. **DON'T OVERREACH.** Keep proper footing and balance at all times.
14. **MAINTAIN TOOLS WITH CARE.** Keep tools sharp and clean for best and safest performance. Follow instructions for lubricating and changing accessories.
15. **DISCONNECT TOOLS** before servicing; when changing accessories, such as blades, bits, cutters, and the like.
16. **REDUCE THE RISK OF UNINTENTIONAL STARTING.** Make sure switch is in off position before plugging in.
17. **USE RECOMMENDED ACCESSORIES.** Consult the owner's manual for recommended accessories. The use of improper accessories may cause risk of injury to persons.
18. **NEVER STAND ON TOOL.** Serious injury could occur if the tool is tipped or if the cutting tool is unintentionally contacted.
19. **CHECK DAMAGED PARTS.** Before further use of the tool, a guard or other part that is damaged should be carefully checked to determine that it will operate properly and perform its intended function – check for alignment of moving parts, binding of moving parts, breakage of parts, mounting, and any other conditions that may affect its operation. A guard or other part that is damaged should be properly repaired or replaced.
20. **DIRECTION OF FEED.** Sand only on the downward moving surface of the disc - sanding on the upward moving surface may result in the workpiece being thrown up and towards the operator.
21. **NEVER LEAVE TOOL RUNNING UNATTENDED. TURN POWER OFF.** Don't leave tool until it comes to a complete stop.

Grounding Instructions



⚠️ WARNING

TO PREVENT ELECTRIC SHOCK AND DEATH FROM INCORRECT GROUNDING WIRE CONNECTION READ AND FOLLOW THESE INSTRUCTIONS:

110-120 VAC Grounded Tools: Tools with Three Prong Plugs

1. In the event of a malfunction or breakdown, grounding provides a path of least resistance for electric current to reduce the risk of electric shock. This tool is equipped with an electric cord having an equipment-grounding conductor and a grounding plug. The plug must be plugged into a matching outlet that is properly installed and grounded in accordance with all local codes and ordinances.
2. Do not modify the plug provided – if it will not fit the outlet, have the proper outlet installed by a qualified electrician.
3. Improper connection of the equipment-grounding conductor can result in a risk of electric shock. The conductor with insulation having an outer surface that is green with or without yellow stripes is the equipment-grounding conductor. If repair or replacement of the electric cord or plug is necessary, do not connect the equipment-grounding conductor to a live terminal.
4. Check with a qualified electrician or service personnel if the grounding instructions are not completely understood, or if in doubt as to whether the tool is properly grounded.
5. Use only 3-wire extension cords that have 3-prong grounding plugs and 3-pole receptacles that accept the tool's plug.

6. Repair or replace damaged or worn cord immediately.

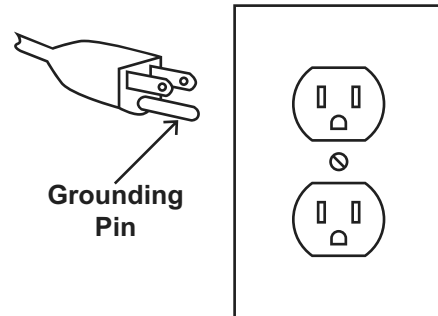

**125 VAC 3-Prong Plug and Outlet
(for up to 125 VAC and up to 15 A)**

7. This tool is intended for use on a circuit that has an outlet that looks like the one illustrated above in **125 VAC 3-Prong Plug and Outlet**. The tool has a grounding plug that looks like the plug illustrated above in **125 VAC 3-Prong Plug and Outlet**.
8. The outlet must be properly installed and grounded in accordance with all codes and ordinances.
9. Do not use an adapter to connect this tool to a different outlet.

Sander Safety Warnings

For Your Own Safety Read Instruction Manual Before Operating Sander

1. Wear eye protection.
2. Support workpiece with worktable.
3. Maintain 1/16 inch maximum clearance between table and sanding disc.
4. Avoid kickback by sanding in accordance with the directional arrows.
5. The worktable is the surface mounted close to the sanding surface that the operator rests the workpiece against to prevent it from being pulled into the machine. For safety, it must be adjusted very close to the sanding surface.
6. Sand only on the downward moving surface of the disc - sanding on the upward moving surface may result in the workpiece being thrown up and towards the operator.
7. Remove Safety Key when the Switch is turned off. Do not leave the Safety Key in the Switch when the tool is not in use.
8. **DO NOT OPERATE WITH ANY GUARD DISABLED, DAMAGED, OR REMOVED. Moving guards must move freely and close instantly.**
9. The use of accessories or attachments not recommended by the manufacturer may result in a risk of injury to persons.
10. When servicing use only identical replacement parts.
11. Only use safety equipment that has been approved by an appropriate standards agency. Unapproved safety equipment may not provide adequate protection. Eye protection must be ANSI-approved and breathing protection must be NIOSH-approved for the specific hazards in the work area.
12. Stay alert, watch what you are doing and use common sense when operating a power tool. Do not use a power tool while you are tired or under the influence of drugs, alcohol or medication. A moment of inattention while operating power tools may result in serious personal injury.
13. Industrial applications must follow OSHA guidelines.
14. Maintain labels and nameplates on the tool. These carry important safety information. If unreadable or missing, contact Harbor Freight Tools for a replacement.
15. Avoid unintentional starting. Prepare to begin work before turning on the tool.
16. People with pacemakers should consult their physician(s) before use. Electromagnetic fields in close proximity to heart pacemaker could cause pacemaker interference or pacemaker failure.
17. Use for sanding wood, plastic and non-ferrous metals only.
18. The warnings, precautions, and instructions discussed in this instruction manual cannot cover all possible conditions and situations that may occur. It must be understood by the operator that common sense and caution are factors which cannot be built into this product, but must be supplied by the operator.

Vibration Safety

SAFETY

This tool vibrates during use. Repeated or long-term exposure to vibration may cause temporary or permanent physical injury, particularly to the hands, arms and shoulders. To reduce the risk of vibration-related injury:

1. Anyone using vibrating tools regularly or for an extended period should first be examined by a doctor and then have regular medical check-ups to ensure medical problems are not being caused or worsened from use. Pregnant women or people who have impaired blood circulation to the hand, past hand injuries, nervous system disorders, diabetes, or Raynaud's Disease should not use this tool. If you feel any medical or physical symptoms related to vibration (such as tingling, numbness, and white or blue fingers), seek medical advice as soon as possible.
2. Do not smoke during use. Nicotine reduces the blood supply to the hands and fingers, increasing the risk of vibration-related injury.
3. Use tools with the lowest vibration when there is a choice between different processes.
4. Include vibration-free periods each day of work.
5. Grip workpiece as lightly as possible (while still keeping safe control of it). Let the tool do the work.
6. To reduce vibration, maintain the tool as explained in this manual. If any abnormal vibration occurs, stop use immediately.



SAVE THESE INSTRUCTIONS.

SETUP

OPERATION

MAINTENANCE

Specifications

Electrical Rating	120VAC / 60Hz / 8A
Disc Size	12"
Maximum Speed	1725 RPM

Setup - Before Use:



Read the **ENTIRE IMPORTANT SAFETY INFORMATION** section at the beginning of this manual including all text under subheadings therein before set up or use of this product.

WARNING

TO PREVENT SERIOUS INJURY FROM ACCIDENTAL OPERATION:

Turn the Power Switch of the tool off and unplug the tool from its electrical outlet before performing any procedure in this section.

Note: For additional information regarding the parts listed in the following pages, refer to the Assembly Diagram near the end of this manual.

Assembly/Mounting

Install Work Table Assembly

1. Set the Disc Sander upright on rubber feet.
2. Slide Work Table onto base frame.
3. **WARNING! TO PREVENT SERIOUS INJURY: To avoid the workpiece or fingers being stuck between the table and sanding disc, the table edge should be set 1/16" away from Sanding Disc.**
4. Thread the Indexing Pin fully into the pivot hole and through the Scale Plate. The Scale Plate slides along the outside of the Indexing Pin Head.

5. Insert the Locking Handle Assembly into the Flat Washer and Scale Plate then into the front hole on each side of the Base Frame.

Note: The Locking Handles are threaded and spring-loaded. Pull out the handle to reposition. Push the handle in and rotate to tighten or loosen the table. Position the handle in the downwards position after tightening to prevent it from interfering with the work table.

Functions

Safety Switch

Insert the Safety Key into the Switch. This Key is a safety precaution and should remain in the Switch during use and be removed after Switch is turned off and/or any time the Disc Sander is left unattended or in storage.

SAFETY

SETUP

OPERATION

MAINTENANCE

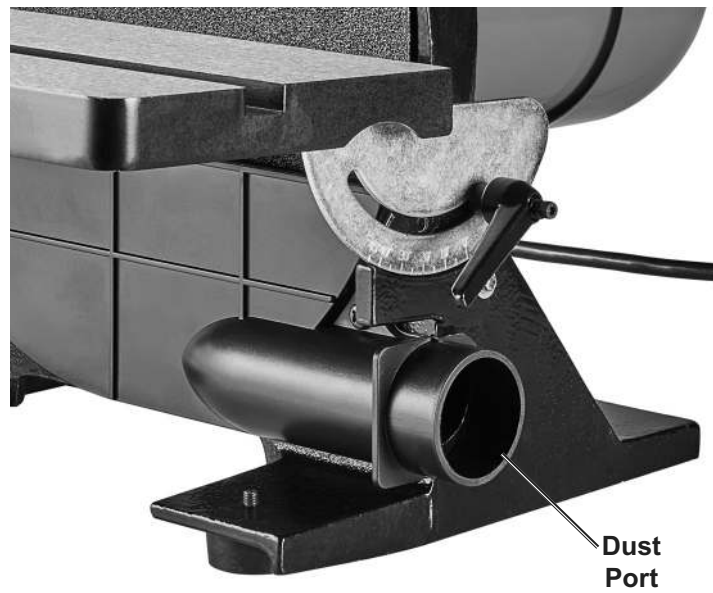
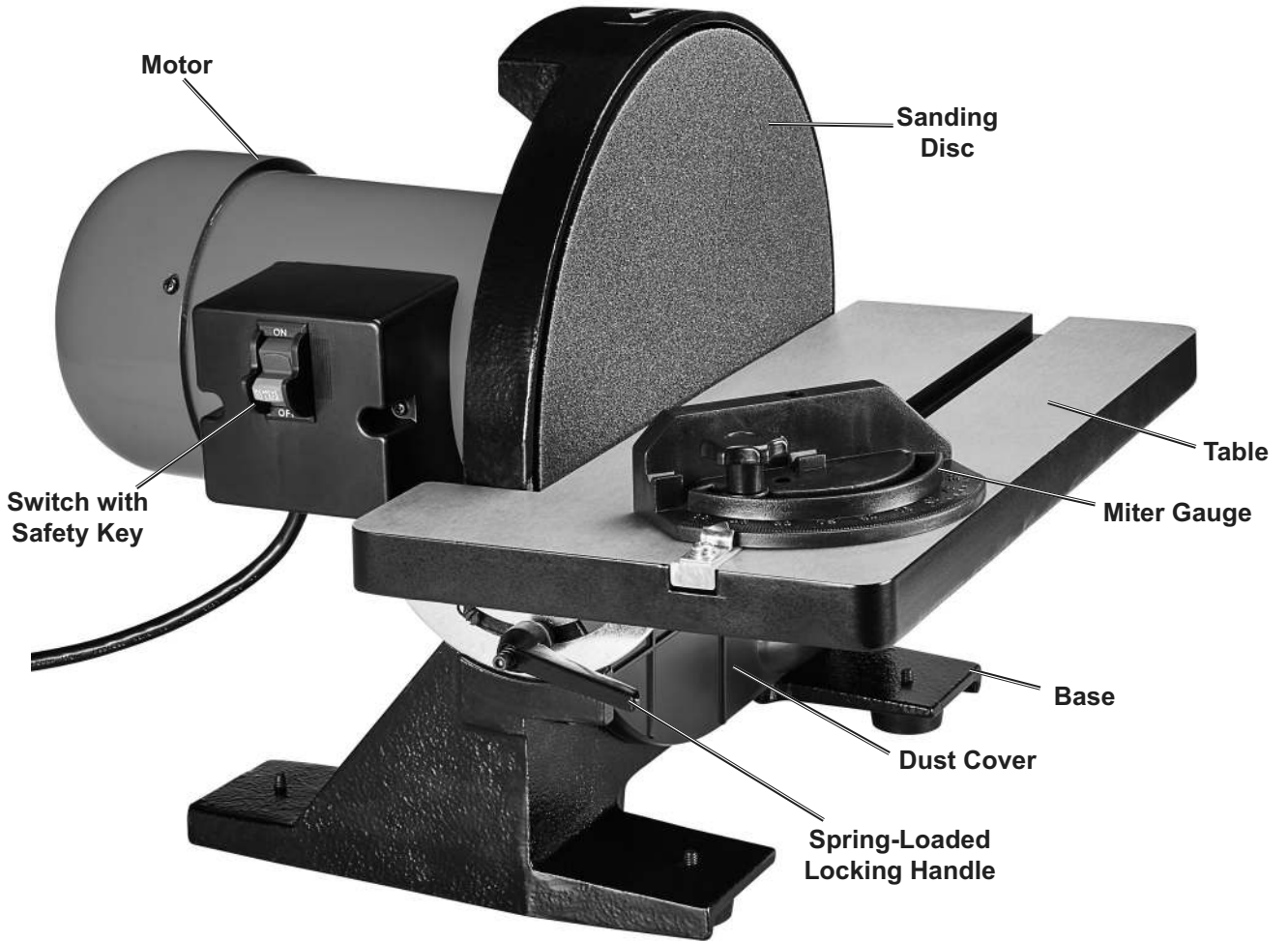

Operating Instructions



Read the **ENTIRE IMPORTANT SAFETY INFORMATION** section at the beginning of this manual including all text under subheadings therein before set up or use of this product.

Tool Set Up

⚠ WARNING

TO PREVENT SERIOUS INJURY FROM ACCIDENTAL OPERATION:

Turn the Power Switch of the tool off and unplug the tool from its electrical outlet before performing any procedure in this section.

TO PREVENT SERIOUS INJURY:

DO NOT OPERATE WITH ANY GUARD DISABLED, DAMAGED, OR REMOVED.

Mounting Sander to Workbench

Note: For temporary mounting, attach a large C-Clamp to each side of the Sander and workbench. For permanent mounting, follow instructions below:

1. Place Sander on a stable workbench.
2. Using the mounting holes mark the hole locations on the workbench.

3. Remove the Sander. Drill two 3/8" holes through the workbench.
4. Align the Sander Base over the mounting holes and secure it using two 5/16" washers and screws, locking washers and nuts. (Mounting hardware not included.)

Leveling the Table

1. Loosen the two Locking Handles. Place a combination square (not included) on the Table so that the combination square touches the Sanding Disc. If the Table is 90° to the disc, the table is level. Always maintain a maximum of 1/16" clearance between the Table and the Sanding Disc. Tighten the Locking Handles.
2. If the Table is not 90° to the Sanding Disc, loosen Locking Handles and tilt Table until it is square with the disc. Retighten Locking Handles.
3. Loosen Screw holding the Angle Pointer and adjust it to point to 90°. Tighten the Screw.

Squaring the Miter Gauge

1. Loosen the Miter Gauge Knob, and set the Miter Gauge to 0°.
2. Place a combination square (not included) against the Sanding Disc and the flat face of the miter gauge. Miter Gauge should be 90° to Sanding Disc.
3. Adjust as needed, then tighten Miter Gauge Knob.
4. Loosen the Screw holding the Miter Gauge Pointer. Adjust it to 0° on the Miter Scale. Tighten Screw and recheck with square.

Replacing Sanding Discs

Note: Before using the Sanding Disc the first time, wipe down the Backing Disc with denatured alcohol (shellac thinner). This will clean the surface, leave no residue and assure a secure bond.

1. Remove the Table, Disc Guard and Dust Cover.

2. Peel off old Sanding Disc. Align perimeter of new Sanding Disc over the Backing Disc and press firmly onto Backing Disc.

Note: Adhesive from old Sanding Disc may leave residue. Wipe the Backing Disc with denatured alcohol (shellac thinner). This will clean the surface, leave no residue and assure a secure bond.

Workpiece and Work Area Set Up

SAFETY

1. Designate a work area that is clean and well lit. The work area must not allow access by children or pets to prevent distraction and injury.
2. Route the power cord along a safe route to reach the work area without creating a tripping hazard or exposing the power cord to possible damage. The power cord must reach the work area with enough extra length to allow free movement while working.
3. Secure loose workpieces using a vise or clamps (not included) to prevent movement while working.
4. There must not be objects, such as utility lines, nearby that will present a hazard while working.

SETUP

OPERATION

MAINTENANCE

General Operating Instructions

1. Make sure that the Switch is in the off-position, then plug in the tool.
2. Insert Safety Key into Switch.
3. Make sure nothing is contacting the Sanding Disc or Belt, then turn on the Switch.
4. When using the Disc Sander, only use the LEFT side of the Sanding Disc (as you face it) to sand. The Sanding Disc turns counterclockwise and using the right side could cause kickback.
5. Use two hands and hold workpiece securely against the table at all times. Press the workpiece against the disc to start sanding. Keep the workpiece moving for a better finish.
6. After use, turn off the tool, remove the Safety Key from the Switch, and disconnect from the power supply. Clean and store the tool indoors out of children's reach.

Bevel Sanding

1. Loosen the two Locking Handles.
2. Tilt table to desire angle using the bevel gauge.
3. Tighten the Locking Handles.

Dust Collection

1. Connect dust hose (not included) to Dust Port.
2. Connect opposite end of hose to dust collection system.

Note: A dust port adapter may be needed depending on the inlet size of your hose.

The logo for Bauer, featuring the word "Bauer" in a bold, italicized, sans-serif font with a trademark symbol (TM) at the end.

Maintenance and Servicing



Procedures not specifically explained in this manual must be performed only by a qualified technician.

WARNING

TO PREVENT SERIOUS INJURY FROM ACCIDENTAL OPERATION:

Turn the Power Switch of the tool off and unplug the tool from its electrical outlet before performing any procedure in this section.

TO PREVENT SERIOUS INJURY FROM TOOL FAILURE:

Do not use damaged equipment. If abnormal noise or vibration occurs, have the problem corrected before further use.

Cleaning, Maintenance, and Lubrication

1. **BEFORE EACH USE**, inspect the general condition of the tool. Check for:
 - loose hardware
 - misalignment or binding of moving parts
 - cracked or broken parts
 - damaged electrical wiring
 - any other condition that may affect its safe operation.
2. **AFTER USE**, turn off the tool, remove the Safety Key from the Switch, and disconnect its power supply. Wipe external surfaces of the tool with clean cloth.
3. A Dust Port is located on the bottom of the Lower Guard Plate. It is held in place with a Screw and can be removed for vacuuming collected dust and sanding residue. Replace the Dust Port after cleaning and tighten Screw.
4. Apply a light coat of paste wax to the Table to make feeding material easier.
5. Use compressed air to blow dust and debris from the Sander and Motor.
6. The Bearings on this Sander are sealed and do not require lubrication.
7. **WARNING! TO PREVENT SERIOUS INJURY:** If the supply cord of this power tool is damaged, it must be replaced only by a qualified service technician.

Troubleshooting

Problem	Possible Causes	Likely Solutions
Disc Sander does not turn on	<ol style="list-style-type: none"> 1. Not plugged in. 2. No power at outlet. 3. Safety Key not inserted into Switch. 4. Switch is not turned "ON". 	<ol style="list-style-type: none"> 1. Plug in Sander. 2. Check power at outlet and/or circuit breaker. 3. Insert Safety Key into Switch. 4. Turn on the Switch.
Motor overheats	<ol style="list-style-type: none"> 1. Motor overloaded. 2. Extension cord too long or insufficient gauge. 	<ol style="list-style-type: none"> 1. Use less pressure. 2. Use appropriate extension cord or plug tool directly into outlet.
Motor slows when sanding	Applying too much pressure while sanding	Use less pressure.
Wood burns while sanding	<ol style="list-style-type: none"> 1. Sanding Disc may be loaded with dirt or debris. 2. Too much pressure. 3. Sanding grit too fine. 	<ol style="list-style-type: none"> 1. Clean or replace disc using instructions in this manual. 2. Use less pressure. 3. Use coarser grit Sanding Disc.
Deep Grooves/ Scars in workpiece	<ol style="list-style-type: none"> 1. Sanding Disc too coarse. 2. Too much pressure. 3. Workpiece being held against disc for too long. 4. Sanding against the grain. 	<ol style="list-style-type: none"> 1. Use finer grit disc. 2. Use less pressure. 3. Keep workpiece moving when sanding. 4. Sand with the grain.
Sanding surface clogs	<ol style="list-style-type: none"> 1. Too much pressure against Sanding Disc. 2. Sanding softwood. 	<ol style="list-style-type: none"> 1. Use less pressure. 2. Clean or replace Sanding Disc frequently.



Follow all safety precautions whenever diagnosing or servicing the tool. Disconnect power supply before service.

PLEASE READ THE FOLLOWING CAREFULLY

THE MANUFACTURER AND/OR DISTRIBUTOR HAS PROVIDED THE PARTS LIST AND ASSEMBLY DIAGRAM IN THIS MANUAL AS A REFERENCE TOOL ONLY. NEITHER THE MANUFACTURER OR DISTRIBUTOR MAKES ANY REPRESENTATION OR WARRANTY OF ANY KIND TO THE BUYER THAT HE OR SHE IS QUALIFIED TO MAKE ANY REPAIRS TO THE PRODUCT, OR THAT HE OR SHE IS QUALIFIED TO REPLACE ANY PARTS OF THE PRODUCT. IN FACT, THE MANUFACTURER AND/OR DISTRIBUTOR EXPRESSLY STATES THAT ALL REPAIRS AND PARTS REPLACEMENTS SHOULD BE UNDERTAKEN BY CERTIFIED AND LICENSED TECHNICIANS, AND NOT BY THE BUYER. THE BUYER ASSUMES ALL RISK AND LIABILITY ARISING OUT OF HIS OR HER REPAIRS TO THE ORIGINAL PRODUCT OR REPLACEMENT PARTS THERETO, OR ARISING OUT OF HIS OR HER INSTALLATION OF REPLACEMENT PARTS THERETO.

Parts List

Part	Description	Qty
1	Motor assembly	
2	Base	1
3	Dust Cover	1
4	Work Table	1
5	M6 Nut	4
6	Scale Plate	2
7	Indexing Pin	2
8	Locking Handle Assembly	2
9	Disc Guard	1
10	Miter Gauge Knob	1
11	Miter Gauge	1
12	M5x8 Screw	1
13	Miter Gauge Pointer	1
14	Miter Gauge Rod	1
15	M6x10 Hex Bolt	6

Part	Description	Qty
16	Rubber Feet	4
17	Flat Washer	7
18	M6x20 Screw	6
19	Rubber Cushion	2
20	M5x10 Screw	2
21	M8x25 Hex Bolt	4
22	Angle Pointer	1
23	M4x8 Screw	1
24	M6x20 Screw	1
25	Disc Plate	1
26	Disc Paper	1
27	Disc Plate Washer	1
28	D5 Plate Washer	2
29	M6x25 Screw	4

Record Product's Serial Number Here: _____

Note: If product has no serial number, record month and year of purchase instead.

Note: Some parts are listed and shown for illustration purposes only, and are not available individually as replacement parts. Specify UPC 193175515421 when ordering parts.

Assembly Diagram

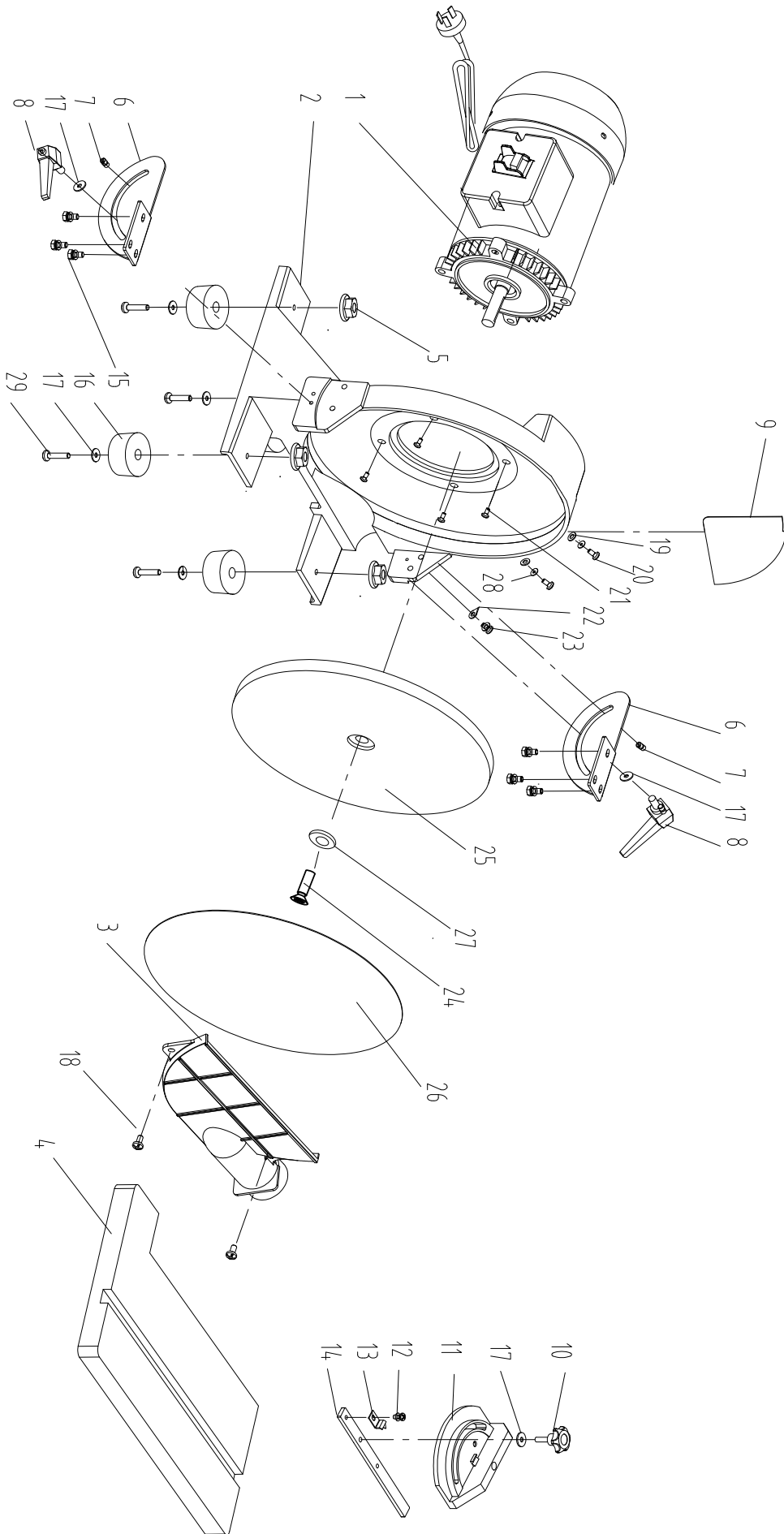

SAFETY

SETUP

OPERATION

MAINTENANCE

Limited 90 Day Warranty

Harbor Freight Tools Co. makes every effort to assure that its products meet high quality and durability standards, and warrants to the original purchaser that this product is free from defects in materials and workmanship for the period of 90 days from the date of purchase. This warranty does not apply to damage due directly or indirectly, to misuse, abuse, negligence or accidents, repairs or alterations outside our facilities, criminal activity, improper installation, normal wear and tear, or to lack of maintenance. We shall in no event be liable for death, injuries to persons or property, or for incidental, contingent, special or consequential damages arising from the use of our product. Some states do not allow the exclusion or limitation of incidental or consequential damages, so the above limitation of exclusion may not apply to you. THIS WARRANTY IS EXPRESSLY IN LIEU OF ALL OTHER WARRANTIES, EXPRESS OR IMPLIED, INCLUDING THE WARRANTIES OF MERCHANTABILITY AND FITNESS.

To take advantage of this warranty, the product or part must be returned to us with transportation charges prepaid. Proof of purchase date and an explanation of the complaint must accompany the merchandise. If our inspection verifies the defect, we will either repair or replace the product at our election or we may elect to refund the purchase price if we cannot readily and quickly provide you with a replacement. We will return repaired products at our expense, but if we determine there is no defect, or that the defect resulted from causes not within the scope of our warranty, then you must bear the cost of returning the product.

This warranty gives you specific legal rights and you may also have other rights which vary from state to state.

The logo for Bauer, featuring the word "Bauer" in a bold, italicized, sans-serif font. The letters are black with a white outline, and a small trademark symbol (TM) is located at the bottom right of the word.

26677 Agoura Road • Calabasas, CA 91302 • 1-888-866-5797