

Owner's Manual & Safety Instructions

Save This Manual Keep this manual for the safety warnings and precautions, assembly, operating, inspection, maintenance and cleaning procedures. Write the product's serial number in the back of the manual (or month and year of purchase if product has no number). Keep this manual and the receipt in a safe and dry place for future reference.

22e

BauerTM

2028E-B

PORTABLE HEAVY DUTY PIPE THREADING KIT



Visit our website at: <http://www.harborfreight.com>
Email our technical support at: productsupport@harborfreight.com

58475

When unpacking, make sure that the product is intact and undamaged. If any parts are missing or broken, please call 1-888-866-5797 as soon as possible.

Copyright© 2021 by Harbor Freight Tools®. All rights reserved.
No portion of this manual or any artwork contained herein may be reproduced in any shape or form without the express written consent of Harbor Freight Tools. Diagrams within this manual may not be drawn proportionally. Due to continuing improvements, actual product may differ slightly from the product described herein.
Tools required for assembly and service may not be included.

⚠ WARNING

**Read this material before using this product.
Failure to do so can result in serious injury.
SAVE THIS MANUAL.**

Table of Contents

Safety	2	Maintenance	12
Specifications	7	Parts List and Diagram	14-18
Setup	8	Warranty	20
Operation	9		

SAFETY



SETUP

OPERATION

MAINTENANCE

WARNING SYMBOLS AND DEFINITIONS	
	This is the safety alert symbol. It is used to alert you to potential personal injury hazards. Obey all safety messages that follow this symbol to avoid possible injury or death.
	Indicates a hazardous situation which, if not avoided, will result in death or serious injury.
	Indicates a hazardous situation which, if not avoided, could result in death or serious injury.
	Indicates a hazardous situation which, if not avoided, could result in minor or moderate injury.
	Addresses practices not related to personal injury.

IMPORTANT SAFETY INFORMATION

General Power Tool Safety Warnings

Read all safety warnings, instructions, illustrations and specifications provided with this power tool. Failure to follow all instructions listed below may result in electric shock, fire and/or serious injury.

Save all warnings and instructions for future reference.

The term "power tool" in the warnings refers to your mains-operated (corded) power tool.

- | | |
|---|---|
| <ol style="list-style-type: none"> 1. Work area safety <ol style="list-style-type: none"> a. Keep work area clean and well lit.
<i>Cluttered or dark areas invite accidents.</i> b. Do not operate power tools in explosive atmospheres, such as in the presence of flammable liquids, gases or dust. <i>Power tools create sparks which may ignite the dust or fumes.</i> c. Keep children and bystanders away while operating a power tool. <i>Distractions can cause you to lose control.</i> | <ol style="list-style-type: none"> 2. Electrical safety <ol style="list-style-type: none"> a. Power tool plugs must match the outlet. Never modify the plug in any way. Do not use any adapter plugs with earthed (grounded) power tools. <i>Unmodified plugs and matching outlets will reduce risk of electric shock.</i> b. Avoid body contact with earthed or grounded surfaces, such as pipes, radiators, ranges and refrigerators. <i>There is an increased risk of electric shock if your body is earthed or grounded.</i> |
|---|---|

- c. **Do not expose power tools to rain or wet conditions.** *Water entering a power tool will increase the risk of electric shock.*
 - d. **Do not abuse the cord. Never use the cord for carrying, pulling or unplugging the power tool. Keep cord away from heat, oil, sharp edges or moving parts.** *Damaged or entangled cords increase the risk of electric shock.*
 - e. **When operating a power tool outdoors, use an extension cord suitable for outdoor use.** *Use of a cord suitable for outdoor use reduces the risk of electric shock.*
 - f. **If operating a power tool in a damp location is unavoidable, use a ground fault circuit interrupter (GFCI) protected supply.** *Use of a GFCI reduces the risk of electric shock.*
3. **Personal safety**
- a. **Stay alert, watch what you are doing and use common sense when operating a power tool. Do not use a power tool while you are tired or under the influence of drugs, alcohol or medication.** *A moment of inattention while operating power tools may result in serious personal injury.*
 - b. **Use personal protective equipment. Always wear eye protection.** *Protective equipment such as dust mask, non-skid safety shoes, hard hat, or hearing protection used for appropriate conditions will reduce personal injuries.*
 - c. **Prevent unintentional starting. Ensure the switch is in the off-position before connecting to power source and/or battery pack, picking up or carrying the tool.** *Carrying power tools with your finger on the switch or energizing power tools that have the switch on invites accidents.*
 - d. **Remove any adjusting key or wrench before turning the power tool on.** *A wrench or a key left attached to a rotating part of the power tool may result in personal injury.*
 - e. **Do not overreach. Keep proper footing and balance at all times.** *This enables better control of the power tool in unexpected situations.*
 - f. **Dress properly. Do not wear loose clothing or jewelry. Keep your hair, clothing and gloves away from moving parts.** *Loose clothes, jewelry or long hair can be caught in moving parts.*
 - g. **If devices are provided for the connection of dust extraction and collection facilities, ensure these are connected and properly used.** *Use of dust collection can reduce dust-related hazards.*
 - h. **Do not let familiarity gained from frequent use of tools allow you to become complacent and ignore tool safety principles.** *A careless action can cause severe injury within a fraction of a second.*
- i. Only use safety equipment that has been approved by an appropriate standards agency. Unapproved safety equipment may not provide adequate protection. Eye protection must be ANSI-approved and breathing protection must be NIOSH-approved for the specific hazards in the work area.
 - j. Avoid unintentional starting. Prepare to begin work before turning on the tool.
 - k. Do not leave the tool unattended when it is plugged into an electrical outlet. Turn off the tool, and unplug it from its electrical outlet before leaving.
 - l. This product is not a toy. Keep it out of reach of children.
 - m. People with pacemakers should consult their physician(s) before use. Electromagnetic fields in close proximity to heart pacemaker could cause pacemaker interference or pacemaker failure. In addition, people with pacemakers should:
 - Avoid operating alone.
 - Do not use with Trigger locked on.
 - Properly maintain and inspect to avoid electrical shock.
 - Properly ground power cord.
 Ground Fault Circuit Interrupter (GFCI) should also be implemented – it prevents sustained electrical shock.
 - n. The warnings, precautions, and instructions discussed in this instruction manual cannot cover all possible conditions and situations that may occur. It must be understood by the operator that common sense and caution are factors which cannot be built into this product, but must be supplied by the operator.
4. **Power tool use and care**
- a. **Do not force the power tool. Use the correct power tool for your application.** *The correct power tool will do the job better and safer at the rate for which it was designed.*
 - b. **Do not use the power tool if the switch does not turn it on and off.** *Any power tool that cannot be controlled with the switch is dangerous and must be repaired.*
 - c. **Disconnect the plug from the power source and/or remove the battery pack, if detachable, from the power tool before making any adjustments, changing accessories, or storing power tools.** *Such preventive safety measures reduce the risk of starting the power tool accidentally.*
 - d. **Store idle power tools out of the reach of children and do not allow persons unfamiliar with the power tool or these instructions to operate the power tool.** *Power tools are dangerous in the hands of untrained users.*

- e. **Maintain power tools and accessories.** Check for misalignment or binding of moving parts, breakage of parts and any other condition that may affect the power tool's operation. If damaged, have the power tool repaired before use. Many accidents are caused by poorly maintained power tools.
 - f. **Keep cutting tools sharp and clean.** Properly maintained cutting tools with sharp cutting edges are less likely to bind and are easier to control.
 - g. **Use the power tool, accessories and tool bits etc. in accordance with these instructions, taking into account the working conditions and the work to be performed.** Use of the power tool for operations different from those intended could result in a hazardous situation.
 - h. **Keep handles and grasping surfaces dry, clean and free from oil and grease.** Slippery handles and grasping surfaces do not allow for safe handling and control of the tool in unexpected situations.
5. **Service**
 - a. **Have your power tool serviced by a qualified repair person using only identical replacement parts.** This will ensure that the safety of the power tool is maintained.
 - b. Maintain labels and nameplates on the tool. These carry important safety information. If unreadable or missing, contact Harbor Freight Tools for a replacement.
 6. **Threader safety warnings**
 - a. **Always use the support device provided with the tool.** Loss of control during operation can result in personal injury.
 - b. **Keep sleeves and jackets buttoned while operating the tool. Do not reach across the tool or pipe.** Clothing can be caught by the pipe or the tool resulting in entanglement.
 - c. **Only one person must control the work process and tool operation.** Additional people involved in the process may result in unintended operation and personal injury.
 - d. **Keep floors dry and free of slippery materials such as oil.** Slippery floors invite accidents.
7. **Vibration Safety**

This tool vibrates during use. Repeated or long-term exposure to vibration may cause temporary or permanent physical injury, particularly to the hands, arms and shoulders. To reduce the risk of vibration-related injury:

 - a. Anyone using vibrating tools regularly or for an extended period should first be examined by a doctor and then have regular medical check-ups to ensure medical problems are not being caused or worsened from use. Pregnant women or people who have impaired blood circulation to the hand, past hand injuries, nervous system disorders, diabetes, or Raynaud's Disease should not use this tool. If you feel any symptoms related to vibration (such as tingling, numbness, and white or blue fingers), seek medical advice as soon as possible.
 - b. Do not smoke during use. Nicotine reduces the blood supply to the hands and fingers, increasing the risk of vibration-related injury.
 - c. Wear suitable gloves to reduce the vibration effects on the user.
 - d. Use tools with the lowest vibration when there is a choice.
 - e. Include vibration-free periods each day of work.
 - f. Grip tool as lightly as possible (while still keeping safe control of it). Let the tool do the work.
 - g. To reduce vibration, maintain the tool as explained in this manual. If any abnormal vibration occurs, stop use immediately.



SAVE THESE INSTRUCTIONS.

⚠️ WARNING



TO PREVENT ELECTRIC SHOCK AND DEATH FROM INCORRECT GROUNDING WIRE CONNECTION:

Check with a qualified electrician if you are in doubt as to whether the outlet is properly grounded. Do not modify the power cord plug provided with the tool. Never remove the grounding prong from the plug. Do not use the tool if the power cord or plug is damaged. If damaged, have it repaired by a service facility before use. If the plug will not fit the outlet, have a proper outlet installed by a qualified electrician.

Grounded Tools: Tools with Three Prong Plugs

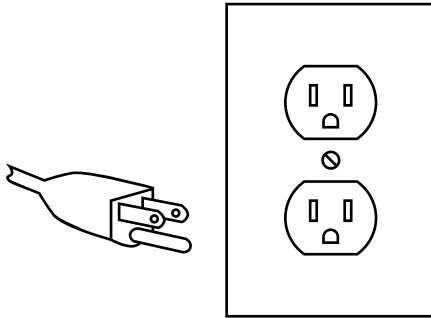

3-Prong Plug and Outlet

1. Tools marked with "Grounding Required" have a three wire cord and three prong grounding plug. The plug must be connected to a properly grounded outlet. If the tool should electrically malfunction or break down, grounding provides a low resistance path to carry electricity away from the user, reducing the risk of electric shock. (See 3-Prong Plug and Outlet.)

2. The grounding prong in the plug is connected through the green wire inside the cord to the grounding system in the tool. The green wire in the cord must be the only wire connected to the tool's grounding system and must never be attached to an electrically "live" terminal. (See 3-Prong Plug and Outlet.)
3. The tool must be plugged into an appropriate outlet, properly installed and grounded in accordance with all codes and ordinances. The plug and outlet should look like those in the preceding illustration. (See 3-Prong Plug and Outlet.)

Double Insulated Tools: Tools with Two Prong Plugs

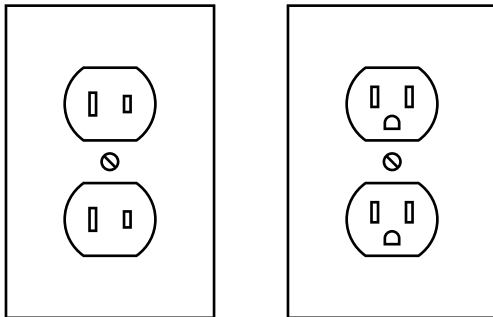

Outlets for 2-Prong Plug

1. Tools marked "Double Insulated" do not require grounding. They have a special double insulation system which satisfies OSHA requirements and complies with the applicable standards of Underwriters Laboratories, Inc., the Canadian Standard Association, and the National Electrical Code.
2. Double insulated tools may be used in either of the 120 volt outlets shown in the preceding illustration. (See Outlets for 2-Prong Plug.)

Bauer

Extension Cords

SAFETY

- Grounded** tools require a three wire extension cord. **Double Insulated** tools can use either a two or three wire extension cord.
- As the distance from the supply outlet increases, you must use a heavier gauge extension cord. Using extension cords with inadequately sized wire causes a serious drop in voltage, resulting in loss of power and possible tool damage. **(See Table A.)**
- The smaller the gauge number of the wire, the greater the capacity of the cord. For example, a 14 gauge cord can carry a higher current than a 16 gauge cord. **(See Table A.)**
- When using more than one extension cord to make up the total length, make sure each cord contains at least the minimum wire size required. **(See Table A.)**
- If you are using one extension cord for more than one tool, add the nameplate amperes and use the sum to determine the required minimum cord size. **(See Table A.)**
- If you are using an extension cord outdoors, make sure it is marked with the suffix "W-A" ("W" in Canada) to indicate it is acceptable for outdoor use.
- Make sure the extension cord is properly wired and in good electrical condition. Always replace a damaged extension cord or have it repaired by a qualified electrician before using it.
- Protect the extension cords from sharp objects, excessive heat, and damp or wet areas.

NAMEPLATE AMPERES (at full load)	EXTENSION CORD LENGTH				
	25'	50'	75'	100'	150'
0 – 2.0	18	18	18	18	16
2.1 – 3.4	18	18	18	16	14
3.5 – 5.0	18	18	16	14	12
5.1 – 7.0	18	16	14	12	12
7.1 – 12.0	18	14	12	10	-
12.1 – 16.0	14	12	10	-	-
16.1 – 20.0	12	10	-	-	-

* Based on limiting the line voltage drop to five volts at 150% of the rated amperes.

SETUP

Symbology

	Double Insulated
	Volts
	Alternating Current
	Amperes
n_0 xxxx/min.	No Load Revolutions per Minute (RPM)

	WARNING marking concerning Risk of Eye Injury. Wear ANSI-approved safety goggles with side shields.
	Read the manual before set-up and/or use.
	WARNING marking concerning Risk of Fire. Do not cover ventilation ducts. Keep flammable objects away.
	WARNING marking concerning Risk of Electric Shock. Properly connect power cord to appropriate outlet.

OPERATION

MAINTENANCE

Specifications

Electrical Rating	120VAC / 60Hz / 12A
Die Size	1/2", 3/4", 1", 1-1/4", 1-1/2" and 2" Dies marked with NPT and sizing (included)

SAFETY

SETUP

OPERATION

MAINTENANCE

Bauer[™]

Setup - Before Use:



Read the **ENTIRE IMPORTANT SAFETY INFORMATION** section at the beginning of this manual including all text under subheadings therein before set up or use of this product.

Note: For additional information regarding the parts listed in the following pages, refer to *Parts List and Diagram* on page 14.

Functions

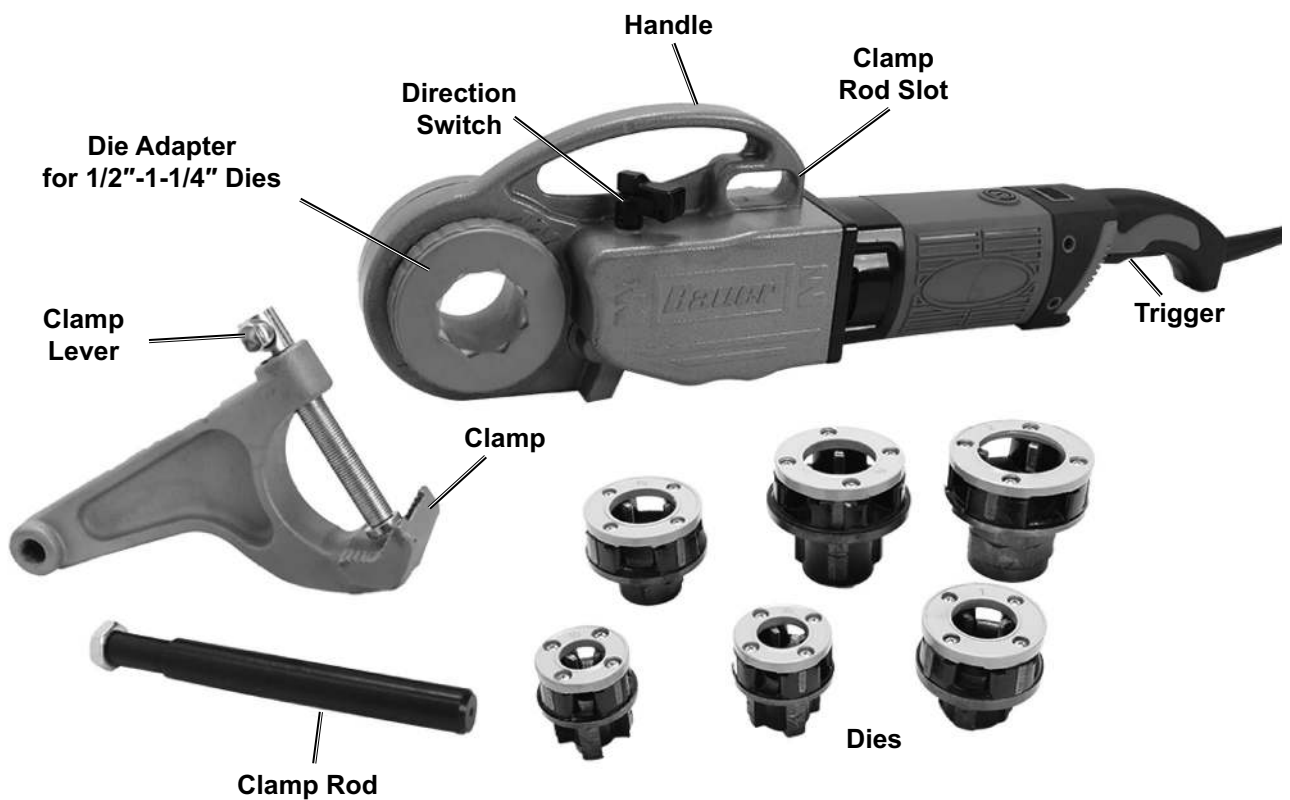

Operating Instructions



Read the **ENTIRE IMPORTANT SAFETY INFORMATION** section at the beginning of this manual including all text under subheadings therein before set up or use of this product.

Tool Set Up

⚠ WARNING

TO PREVENT SERIOUS INJURY FROM ACCIDENTAL OPERATION:

Make sure that the Trigger is in the off-position and unplug the tool from its electrical outlet before performing any procedure in this section.

1. If 1/2" to 1-1/4" Die will be required, Install Die Adapter.
2. Insert Die Adapter on appropriate side of Pipe Threader.
3. Install Retaining Ring onto Die Adapter.

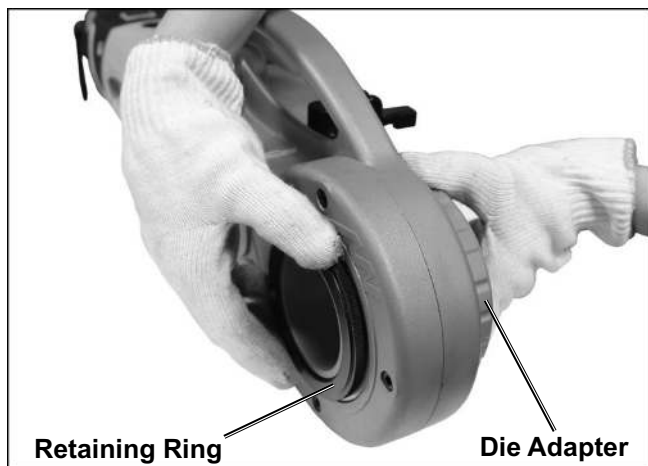

4. Select appropriate Die for the pipe to be threaded.

Note: Dies are intended for use on standard schedule 40 steel pipe.

5. Insert Die into the Die Adapter of Pipe Threader. Make sure Die is secured in place before proceeding.



6. If 1-1/2" or 2" Dies are required, remove Die Adapter and insert Die into Pipe Threader.

Note: Dies can be inserted from either side of Pipe Threader along with Die Adapter, with proper consideration for Clamp and rotation direction.

Note: Dies are held in place with a retaining spring, so removing a properly-inserted Die may require light tapping with a wooden mallet (sold separately).

7. Fill the Oil Can (included) with Thread Cutting Oil (not included). Keep it nearby during the threading operation.

Bauer[™]

Workpiece and Work Area Set Up

SAFETY

1. Designate a work area that is clean and well lit. Work area must not allow access by children or pets to prevent distraction and injury.
 2. Route power cord along a safe route to reach the work area without creating a tripping hazard or exposing the power cord to possible damage. Power cord must reach the work area with enough extra length to allow free movement while working.
 3. There must not be objects, such as utility lines, nearby that will present a hazard while working.
 4. Clamp pipe securely into proper Pipe Vise (sold separately) to keep it from moving during threading.
 5. Use Clamp assembly to secure and support pipe during threading operation. Screw Clamp Rod into Clamp. Make sure pipe is secured to Clamp assembly and is supported during threading operation.
 6. Install Clamp Rod into Clamp Rod Slot. Ensure Clamp Lever can be adjusted easily from above. Be certain that pipe has enough clearance to proceed.
- Note:** Pipe end to be threaded must be clean and chamfered.
7. Insert pipe into toothless end of Die. Make sure inside diameter of Die matches outside diameter of pipe.

SETUP

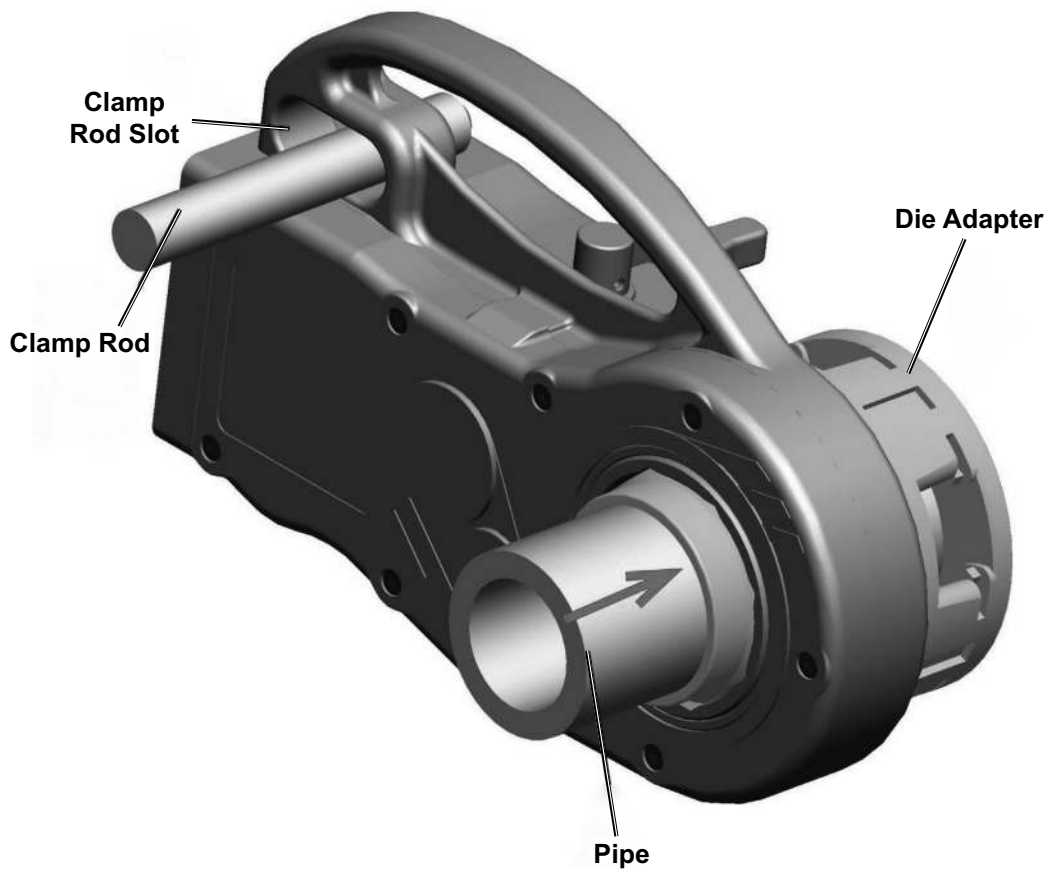

OPERATION

MAINTENANCE

Bauer[™]

General Operating Instructions

1. Make sure pipe end and threads of Die are sufficiently oiled at all times. (Oil sold separately.) Otherwise, the life of the Die Blades will be shortened and the threads will be rough.



2. The Direction Switch determines the direction of the threading operation. Flip Rotating Direction Switch cover open. Rotate Direction Switch back towards Trigger handle for a **clockwise** rotation.
3. Make sure Trigger is in off-position, then plug in tool.
4. While holding Handle, press Trigger in and squeeze Handle.
5. If the Die does not engage the pipe, use a block of scrap wood (not included) that is larger than the Die to apply slight pressure on the end of the Die until it engages pipe.



6. From this point, the Die will automatically be drawn over the pipe and a standard taper thread will be cut.
 7. To ensure a good, clean standard taper thread, stop Pipe Threader every few turns, Reverse, oil the pipe, and re-cut thread.
 8. Stop threading when the end of the Die is flush with the end of the pipe. At this point, the correct thread length has been reached to produce the proper joint. To continue beyond this point would make a straight or running thread.
 9. To finish threading operation:
 - a. Release Trigger. Allow Pipe Threader to completely stop.
 - b. Reverse Direction Switch.
 - c. Squeeze Trigger to turn on Pipe Threader. Allow Die to reverse path of thread until it has fully expelled pipe.
 - d. Release Trigger. Avoid damaging newly cut threads when removing pipe from Pipe Threader.
- CAUTION!** Freshly cut threads may be hot and have sharp edges or sharp metal turnings still attached. Clean pipe and allow it to cool before use.
10. **IMPORTANT:** Clean any oil spills on the ground. At the end of each job, clean Pipe Threader and store in a clean, dry, safe location out of reach of children and unauthorized people.
 11. To prevent accidents, turn off tool and unplug it after use. Clean, then store tool indoors out of children's reach.

SAFETY

SETUP

OPERATION

MAINTENANCE

Maintenance and Servicing



Procedures not specifically explained in this manual must be performed only by a qualified technician.

WARNING

TO PREVENT SERIOUS INJURY FROM ACCIDENTAL OPERATION:
Make sure that the Trigger is in the off-position and unplug the tool from its electrical outlet before performing any procedure in this section.

TO PREVENT SERIOUS INJURY FROM TOOL FAILURE:
Do not use damaged equipment. If abnormal noise or vibration occurs, have the problem corrected before further use.

Cleaning, Maintenance, and Lubrication

- BEFORE EACH USE**, inspect the general condition of the tool. Check for:
 - loose hardware,
 - misalignment or binding of moving parts,
 - damaged cord/electrical wiring,
 - cracked or broken parts, and
 - any other condition that may affect its safe operation.
- AFTER USE**, wipe external surfaces of the tool with clean cloth.
- WARNING! TO PREVENT SERIOUS INJURY:** If the supply cord of this power tool is damaged, it must be replaced only by a qualified service technician.

To Replace the Die Blades

- Worn Die Blades can result in poor thread quality. When replacing Die Blades, verify that the size of the new Die Blades corresponds to the size of the Die (1/2", 3/4", 1", 1-1/4", 1-1/2" and 2"). To replace the Die Blades:
 - Remove the four Screws on the Die.
 - Remove the Ring from the Die.
 - Remove all four Die Blades.
 - Insert four new Die Blades into the Die.
NOTE: When inserting the Die Blades, make sure the cutting edges of the Die Blades face inward and that the number on each Die Blade is at the top and in sequence.

- Once the Die Blades are properly inserted, replace the Ring and four Screws.

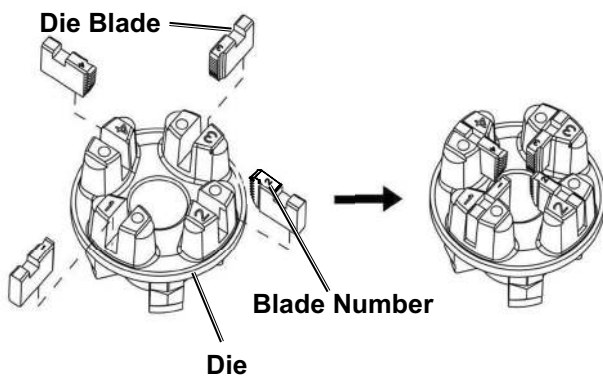
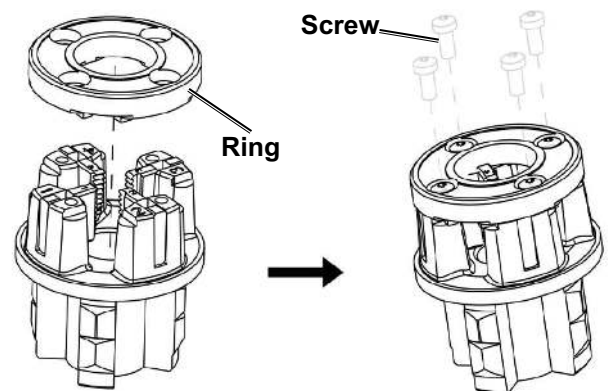

Troubleshooting

Problem	Possible Causes	Likely Solutions
Tool will not start.	<ol style="list-style-type: none"> 1. Cord not connected. 2. No power at outlet. 3. Tool's thermal reset breaker tripped (if equipped). 4. Internal damage or wear. (Carbon brushes or Trigger, for example.) 	<ol style="list-style-type: none"> 1. Check that cord is plugged in. 2. Check power at outlet. If outlet is unpowered, turn off tool and check circuit breaker. If breaker is tripped, make sure circuit is right capacity for tool and circuit has no other loads. 3. Turn off tool and allow to cool. Press reset button on tool. 4. Have technician service tool.
Tool operates slowly.	<ol style="list-style-type: none"> 1. Forcing tool to work too fast. 2. Extension cord too long or cord diameter too small. 	<ol style="list-style-type: none"> 1. Allow tool to work at its own rate. 2. Eliminate use of extension cord. If an extension cord is needed, use one with the proper diameter for its length and load. See <i>Extension Cords</i> in <i>Grounding</i> section on page 5.
Performance decreases over time.	Carbon brushes worn or damaged.	Have qualified technician replace brushes.
Excessive noise or rattling.	Internal damage or wear. (Carbon brushes or bearings, for example.)	Have technician service tool.
Overheating.	<ol style="list-style-type: none"> 1. Forcing tool to work too fast. 2. Blocked motor housing vents. 3. Motor being strained by long or small diameter extension cord. 	<ol style="list-style-type: none"> 1. Allow tool to work at its own rate. 2. Wear ANSI-approved safety goggles and NIOSH-approved dust mask/respirator while blowing dust out of motor using compressed air. 3. Eliminate use of extension cord. If an extension cord is needed, use one with the proper diameter for its length and load. See <i>Extension Cords</i> in <i>Grounding</i> section on page 5.
Pipe doesn't fit Die.	<ol style="list-style-type: none"> 1. Die is inappropriate to pipe size. 2. Pipe inserted from wrong side. 3. Pipe not chamfered. 	<ol style="list-style-type: none"> 1. Choose a Die appropriate to the pipe. 2. Insert pipe from correct side. See <i>Workpiece and Work Area Set Up</i> on page 10. 3. Make sure pipe end-to-be-threaded is chamfered.
Pipe spins.	Clamp is upside-down for the rotation direction.	Move Clamp Bar to other side of Clamp. Turn Clamp upside down and reclamp it to pipe. See <i>Workpiece and Area Set Up</i> on page 10.
Dies break.	<ol style="list-style-type: none"> 1. Die Blades insufficiently lubricated. 2. Die Blades installed in wrong order or backwards. 	<ol style="list-style-type: none"> 1. Lubricate Die Blades sufficiently. See <i>General Operating Instructions</i> section on page 11. 2. Ensure cutting edges of Blades face inward and the number on each Die Blade is at the top and in sequence. See <i>To Replace the Die Blades</i> section on page 12.



**Follow all safety precautions whenever diagnosing or servicing the tool.
Disconnect power supply before service.**

SAFETY

SETUP

OPERATION

MAINTENANCE

Gear Box Parts List

SAFETY

Part	Description	Qty
1	Bevel Gear Set	1
2	Bushing	2
3	Extension Lever	1
4	Pin	1
5	Directional Switch	1
6	Switch Bar	1
7	Pin	1
8	Gear Housing	1
9	Bearing Bronze	2
10	Spring Ring	1
11	Ring Gear	1
12	Needle Bearing	2

Part	Description	Qty
13	Transition Gear	1
14	Steel Ball	1
15	Spring	1
16	Screw	1
17	Output Gear Assembly	1
18	3 Linkage Gear	1
19	Feeding Gear Shaft	1
20	Bearing	1
21	Bevel Gear Set	1
22	Gear Cover (with item 8)	1
23	Washer	9
24	Screw	9
25	Bearing	1

SETUP

OPERATION

MAINTENANCE

Motor Parts List

SAFETY

Part	Description	Qty
1A	Back Handle Assembly	4
2A	Sealing Ring	1
3A	Washer	1
4A	Wire Plate	1
5A	Screw	2
6A	Cover	1
7A	Screw	8
8A	Screw	2
9A	Screw	1
10A	220/110V Carbon Brush	1
11A	Screw	2
12A	Wind Collecting Plate	1
13A	Bearing	1

Part	Description	Qty
14A	Brush Holder Assembly	1
15A	Wiring Harnesses	1
16A	Motor Shell	1
17A	Motor End Cap	1
18A	Switch	1
19A	220V Rotor Assembly	1
20A	220V Stator Assembly	1
20A	110V Rotor Assembly	1
20A	110V Stator Assembly	1
21A	Front Handle Assembly	1

Note: When ordering replacement parts from this list, the "A" suffix must be included in order to get the correct part.

SETUP

OPERATION

MAINTENANCE

Motor Assembly Diagram

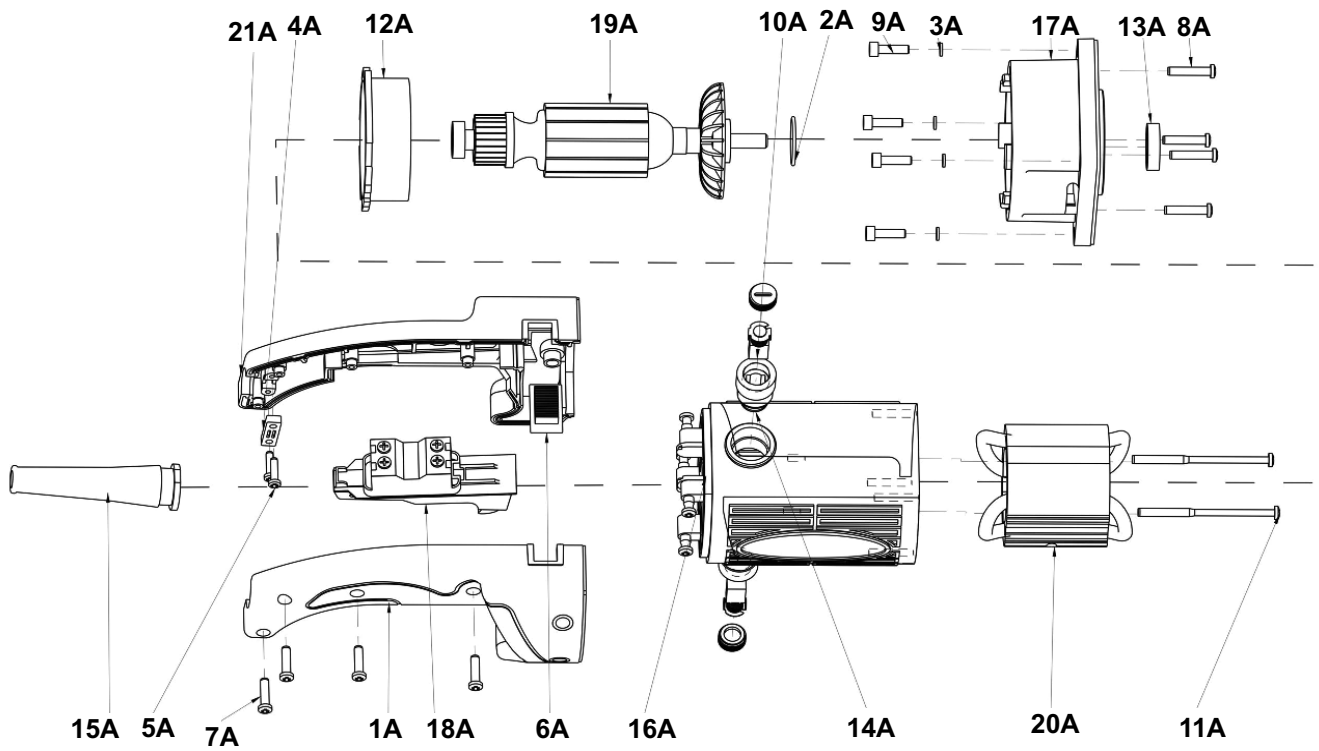

SAFETY

SETUP

OPERATION

MAINTENANCE

Dies Parts List

SAFETY

Part	Description	Qty
1B	1/2" Die Heads With SS Dies, NPT	1
2B	3/4" Die Heads With SS Dies, NPT	1
3B	1" Die Heads With SS Dies, NPT	1
4B	1-1/4" Die Heads With SS Dies, NPT	1
5B	1-1/2" Die Heads With SS Dies, NPT	1
6B	2" Die Heads With SS Dies, NPT	1

Note: When ordering replacement parts from this list, the "B" suffix must be included in order to get the correct part.

Dies Assembly Diagram

SETUP

OPERATION

MAINTENANCE

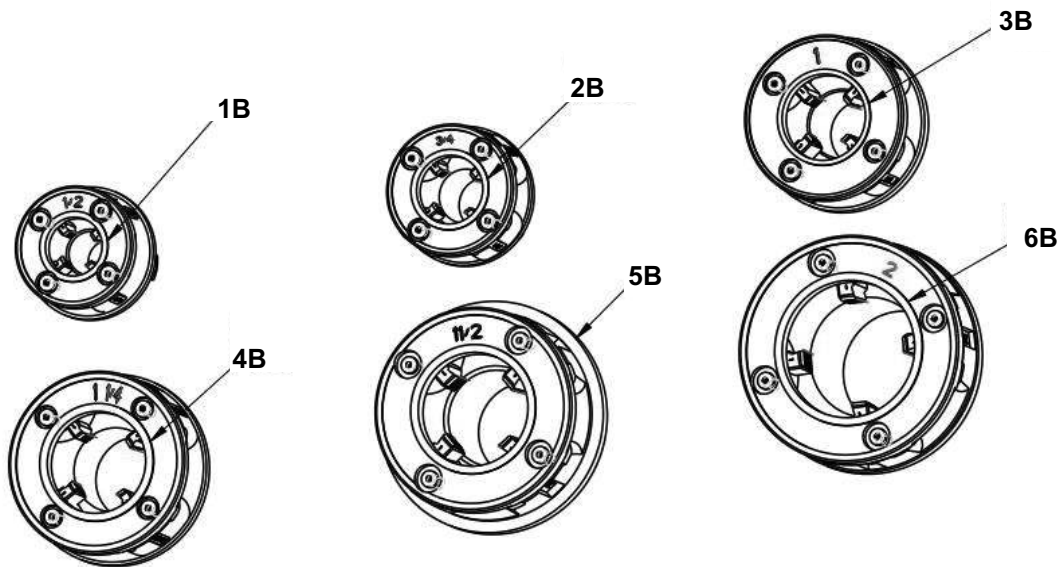

PLEASE READ THE FOLLOWING CAREFULLY

THE MANUFACTURER AND/OR DISTRIBUTOR HAS PROVIDED THE PARTS LIST AND ASSEMBLY DIAGRAM IN THIS MANUAL AS A REFERENCE TOOL ONLY. NEITHER THE MANUFACTURER OR DISTRIBUTOR MAKES ANY REPRESENTATION OR WARRANTY OF ANY KIND TO THE BUYER THAT HE OR SHE IS QUALIFIED TO MAKE ANY REPAIRS TO THE PRODUCT, OR THAT HE OR SHE IS QUALIFIED TO REPLACE ANY PARTS OF THE PRODUCT. IN FACT, THE MANUFACTURER AND/OR DISTRIBUTOR EXPRESSLY STATES THAT ALL REPAIRS AND PARTS REPLACEMENTS SHOULD BE UNDERTAKEN BY CERTIFIED AND LICENSED TECHNICIANS, AND NOT BY THE BUYER. THE BUYER ASSUMES ALL RISK AND LIABILITY ARISING OUT OF HIS OR HER REPAIRS TO THE ORIGINAL PRODUCT OR REPLACEMENT PARTS THERETO, OR ARISING OUT OF HIS OR HER INSTALLATION OF REPLACEMENT PARTS THERETO.

SAFETY

SETUP

OPERATION

MAINTENANCE

Record Product's Serial Number Here: _____

Note: If product has no serial number, record month and year of purchase instead.

Note: Some parts are listed and shown for illustration purposes only, and are not available individually as replacement parts. Specify UPC 193175440044 when ordering parts.

Limited 90 Day Warranty

Harbor Freight Tools Co. makes every effort to assure that its products meet high quality and durability standards, and warrants to the original purchaser that this product is free from defects in materials and workmanship for the period of 90 days from the date of purchase. This warranty does not apply to damage due directly or indirectly, to misuse, abuse, negligence or accidents, repairs or alterations outside our facilities, criminal activity, improper installation, normal wear and tear, or to lack of maintenance. We shall in no event be liable for death, injuries to persons or property, or for incidental, contingent, special or consequential damages arising from the use of our product. Some states do not allow the exclusion or limitation of incidental or consequential damages, so the above limitation of exclusion may not apply to you. THIS WARRANTY IS EXPRESSLY IN LIEU OF ALL OTHER WARRANTIES, EXPRESS OR IMPLIED, INCLUDING THE WARRANTIES OF MERCHANTABILITY AND FITNESS.

To take advantage of this warranty, the product or part must be returned to us with transportation charges prepaid. Proof of purchase date and an explanation of the complaint must accompany the merchandise. If our inspection verifies the defect, we will either repair or replace the product at our election or we may elect to refund the purchase price if we cannot readily and quickly provide you with a replacement. We will return repaired products at our expense, but if we determine there is no defect, or that the defect resulted from causes not within the scope of our warranty, then you must bear the cost of returning the product.

This warranty gives you specific legal rights and you may also have other rights which vary from state to state.

The logo for Bauer, featuring the word "Bauer" in a bold, italicized, sans-serif font. A small trademark symbol (TM) is located at the bottom right of the word.

26677 Agoura Road • Calabasas, CA 91302 • 1-888-866-5797