

Owner's Manual & Safety Instructions

Save This Manual Keep this manual for the safety warnings and precautions, assembly, operating, inspection, maintenance and cleaning procedures. Write the product's serial number in the back of the manual near the assembly diagram (or month and year of purchase if product has no number). Keep this manual and the receipt in a safe and dry place for future reference.

24f

BauerTM

2327E-B

8" 4.8 AMP GRINDER AND BELT SANDER COMBO



Visit our website at: <http://www.harborfreight.com>
Email our technical support at: productsupport@harborfreight.com

58871

When unpacking, make sure that the product is intact and undamaged. If any parts are missing or broken, please call 1-888-866-5797 as soon as possible.

Copyright© 2024 by Harbor Freight Tools®. All rights reserved.
No portion of this manual or any artwork contained herein may be reproduced in any shape or form without the express written consent of Harbor Freight Tools. Diagrams within this manual may not be drawn proportionally. Due to continuing improvements, actual product may differ slightly from the product described herein.
Tools required for assembly and service may not be included.

⚠ WARNING

Read this material before using this product.
Failure to do so can result in serious injury.
SAVE THIS MANUAL.

Table of Contents

| | | | |
|----------------------|---|------------------------------|----|
| Safety | 2 | Maintenance | 12 |
| Specifications | 7 | Parts List and Diagram | 14 |
| Setup | 7 | Warranty | 16 |
| Operation | 9 | | |

SAFETY



SETUP

WARNING SYMBOLS AND DEFINITIONS

| | |
|--|--|
| | This is the safety alert symbol. It is used to alert you to potential personal injury hazards. Obey all safety messages that follow this symbol to avoid possible injury or death. |
| | Indicates a hazardous situation which, if not avoided, will result in death or serious injury. |
| | Indicates a hazardous situation which, if not avoided, could result in death or serious injury. |
| | Indicates a hazardous situation which, if not avoided, could result in minor or moderate injury. |
| | Addresses practices not related to personal injury. |

OPERATION

IMPORTANT SAFETY INFORMATION

General Power Tool Safety Warnings

WARNING

Read all safety warnings, instructions, illustrations and specifications provided with this power tool. Failure to follow all instructions listed below may result in electric shock, fire and/or serious injury.

Save all warnings and instructions for future reference.

The term "power tool" in the warnings refers to your mains-operated (corded) power tool or battery-operated (cordless) power tool.

- | | |
|--|---|
| <p>1. Work area safety</p> <ul style="list-style-type: none"> a. Keep work area clean and well lit. Cluttered or dark areas invite accidents. b. Do not operate power tools in explosive atmospheres, such as in the presence of flammable liquids, gases or dust. Power tools create sparks which may ignite the dust or fumes. c. Keep children and bystanders away while operating a power tool. Distractions can cause you to lose control. | <p>2. Electrical safety</p> <ul style="list-style-type: none"> a. Power tool plugs must match the outlet. Never modify the plug in any way. Do not use any adapter plugs with earthed (grounded) power tools. Unmodified plugs and matching outlets will reduce risk of electric shock. b. Avoid body contact with earthed or grounded surfaces, such as pipes, radiators, ranges and refrigerators. There is an increased risk of electric shock if your body is earthed or grounded. |
|--|---|

MAINTENANCE

- c. **Do not expose power tools to rain or wet conditions.** *Water entering a power tool will increase the risk of electric shock.*
 - d. **Do not abuse the cord. Never use the cord for carrying, pulling or unplugging the power tool. Keep cord away from heat, oil, sharp edges or moving parts.** *Damaged or entangled cords increase the risk of electric shock.*
 - e. **When operating a power tool outdoors, use an extension cord suitable for outdoor use.** *Use of a cord suitable for outdoor use reduces the risk of electric shock.*
 - f. **If operating a power tool in a damp location is unavoidable, use a ground fault circuit interrupter (GFCI) protected supply.** *Use of a GFCI reduces the risk of electric shock.*
3. **Personal safety**
- a. **Stay alert, watch what you are doing and use common sense when operating a power tool. Do not use a power tool while you are tired or under the influence of drugs, alcohol or medication.** *A moment of inattention while operating power tools may result in serious personal injury.*
 - b. **Use personal protective equipment. Always wear eye protection.** *Protective equipment such as dust mask, non-skid safety shoes, hard hat, or hearing protection used for appropriate conditions will reduce personal injuries.*
 - c. **Prevent unintentional starting. Ensure the switch is in the off-position before connecting to power source and/or battery pack, picking up or carrying the tool.** *Carrying power tools with your finger on the switch or energizing power tools that have the switch on invites accidents.*
 - d. **Remove any adjusting key or wrench before turning the power tool on.** *A wrench or a key left attached to a rotating part of the power tool may result in personal injury.*
 - e. **Do not overreach. Keep proper footing and balance at all times.** *This enables better control of the power tool in unexpected situations.*
 - f. **Dress properly. Do not wear loose clothing or jewelry. Keep your hair, clothing and gloves away from moving parts.** *Loose clothes, jewelry or long hair can be caught in moving parts.*
 - g. **If devices are provided for the connection of dust extraction and collection facilities, ensure these are connected and properly used.** *Use of dust collection can reduce dust-related hazards.*
 - h. **Do not let familiarity gained from frequent use of tools allow you to become complacent and ignore tool safety principles.** *A careless action can cause severe injury within a fraction of a second.*
 - i. Only use safety equipment that has been approved by an appropriate standards agency. Unapproved safety equipment may not provide adequate protection. Eye protection must be ANSI-approved and breathing protection must be NIOSH-approved for the specific hazards in the work area.
 - j. Avoid unintentional starting. Prepare to begin work before turning on the tool.
 - k. Do not leave the tool unattended when it is plugged into an electrical outlet. Turn off the tool, and unplug it from its electrical outlet before leaving.
 - l. This product is not a toy. Keep it out of reach of children.
 - m. People with pacemakers should consult their physician(s) before use. Electromagnetic fields in close proximity to heart pacemaker could cause pacemaker interference or pacemaker failure. In addition, people with pacemakers should:
 - Avoid operating alone.
 - Properly maintain and inspect to avoid electrical shock.
 - Properly ground power cord.Ground Fault Circuit Interrupter (GFCI) should also be implemented – it prevents sustained electrical shock.
 - n. Stay alert, watch what you are doing and use common sense when operating a power tool. Do not use a power tool while you are tired or under the influence of drugs, alcohol or medication. A moment of inattention while operating power tools may result in serious personal injury.
 - o. The warnings, precautions, and instructions discussed in this instruction manual cannot cover all possible conditions and situations that may occur. It must be understood by the operator that common sense and caution are factors which cannot be built into this product, but must be supplied by the operator.
4. **Power tool use and care**
- a. **Do not force the power tool. Use the correct power tool for your application.** *The correct power tool will do the job better and safer at the rate for which it was designed.*
 - b. **Do not use the power tool if the switch does not turn it on and off.** *Any power tool that cannot be controlled with the switch is dangerous and must be repaired.*
 - c. **Disconnect the plug from the power source and/or remove the battery pack, if detachable, from the power tool before making any adjustments, changing accessories, or storing power tools.** *Such preventive safety measures reduce the risk of starting the power tool accidentally.*

- d. **Store idle power tools out of the reach of children and do not allow persons unfamiliar with the power tool or these instructions to operate the power tool.** *Power tools are dangerous in the hands of untrained users.*
 - e. **Maintain power tools and accessories. Check for misalignment or binding of moving parts, breakage of parts and any other condition that may affect the power tool's operation. If damaged, have the power tool repaired before use.** *Many accidents are caused by poorly maintained power tools.*
 - f. **Keep cutting tools sharp and clean.** *Properly maintained cutting tools with sharp cutting edges are less likely to bind and are easier to control.*
 - g. **Use the power tool, accessories and tool bits etc. in accordance with these instructions, taking into account the working conditions and the work to be performed.** *Use of the power tool for operations different from those intended could result in a hazardous situation.*
 - h. **Keep handles and grasping surfaces dry, clean and free from oil and grease.** *Slippery handles and grasping surfaces do not allow for safe handling and control of the tool in unexpected situations.*
5. **Service**
 - a. **Have your power tool serviced by a qualified repair person using only identical replacement parts.** *This will ensure that the safety of the power tool is maintained.*
 - b. Maintain labels and nameplates on the tool. These carry important safety information. If unreadable or missing, contact Harbor Freight Tools for a replacement.
 - c. When servicing use only identical replacement parts.
 6. **Bench Grinder safety warnings**
 - a. **Do not use a damaged accessory. Before each use, inspect the accessory such as abrasive wheels for chips and cracks. After inspecting and installing an accessory, position yourself and bystanders away from the plane of the rotating accessory and run the power tool at maximum no-load speed for one minute.** *Damaged accessories will normally break apart during this test time.*
 - b. **The rated speed of the accessory must be at least equal to the maximum speed marked on the power tool.** *Accessories running faster than their rated speed can break and fly apart.*
 - c. **Never grind on the sides of a grinding wheel.** *Grinding on the side can cause the wheel to break and fly apart.*
 7. **Belt Sander safety warnings**
 - a. Wear eye protection.
 - b. Support workpiece with miter gauge, work stop, or worktable.
 - c. The work stop is a fence near the sanding surface that helps the operator maintain control of the workpiece and prevents the workpiece from being pulled into the machine. For safety, it must be adjusted very close to the sanding surface.
 - d. The sanding belt is designed to rotate down towards the table. Sand on the belt with the workpiece in front of the work stop.
 - e. The use of accessories or attachments not recommended by the manufacturer may result in a risk of injury to persons.
 - f. Industrial applications must follow OSHA guidelines.
 - g. Avoid unintentional starting. Prepare to begin work before turning on the tool.
 8. **Vibration Safety**

This tool vibrates during use. Repeated or long-term exposure to vibration may cause temporary or permanent physical injury, particularly to the hands, arms and shoulders. To reduce the risk of vibration-related injury:

 - a. Anyone using vibrating tools regularly or for an extended period should first be examined by a doctor and then have regular medical check-ups to ensure medical problems are not being caused or worsened from use. Pregnant women or people who have impaired blood circulation to the hand, past hand injuries, nervous system disorders, diabetes, or Raynaud's Disease should not use this tool. If you feel any symptoms related to vibration (such as tingling, numbness, and white or blue fingers), seek medical advice as soon as possible.
 - b. Do not smoke during use. Nicotine reduces the blood supply to the hands and fingers, increasing the risk of vibration-related injury.
 - c. Wear suitable gloves to reduce the vibration effects on the user.
 - d. Use tools with the lowest vibration when there is a choice.
 - e. Include vibration-free periods each day of work.
 - f. Grip tool as lightly as possible (while still keeping safe control of it). Let the tool do the work.
 - g. To reduce vibration, maintain the tool as explained in this manual. If any abnormal vibration occurs, stop use immediately.

Grounding

⚠️ WARNING



TO PREVENT ELECTRIC SHOCK AND DEATH FROM INCORRECT GROUNDING WIRE CONNECTION:

Check with a qualified electrician if you are in doubt as to whether the outlet is properly grounded. Do not modify the power cord plug provided with the tool. Never remove the grounding prong from the plug. Do not use the tool if the power cord or plug is damaged. If damaged, have it repaired by a service facility before use. If the plug will not fit the outlet, have a proper outlet installed by a qualified electrician.

Grounded Tools: Tools with Three Prong Plugs

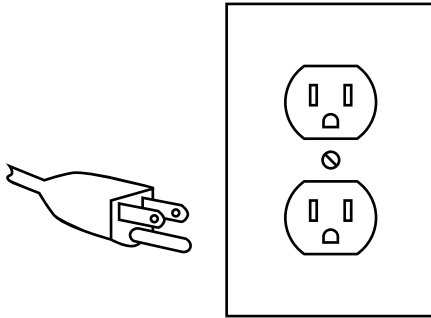

3-Prong Plug and Outlet

1. Tools marked with "Grounding Required" have a three wire cord and three prong grounding plug. The plug must be connected to a properly grounded outlet. If the tool should electrically malfunction or break down, grounding provides a low resistance path to carry electricity away from the user, reducing the risk of electric shock. (See 3-Prong Plug and Outlet.)

2. The grounding prong in the plug is connected through the green wire inside the cord to the grounding system in the tool. The green wire in the cord must be the only wire connected to the tool's grounding system and must never be attached to an electrically "live" terminal. (See 3-Prong Plug and Outlet.)
3. The tool must be plugged into an appropriate outlet, properly installed and grounded in accordance with all codes and ordinances. The plug and outlet should look like those in the preceding illustration. (See 3-Prong Plug and Outlet.)

Double Insulated Tools: Tools with Two Prong Plugs

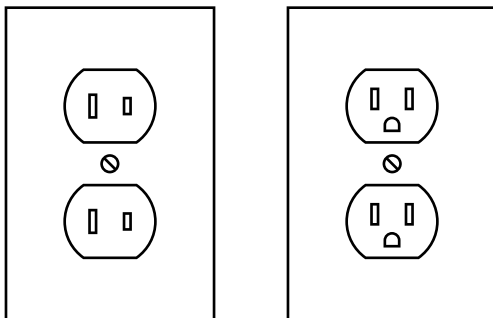

Outlets for 2-Prong Plug

1. Tools marked "Double Insulated" do not require grounding. They have a special double insulation system which satisfies OSHA requirements and complies with the applicable standards of Underwriters Laboratories, Inc., the Canadian Standard Association, and the National Electrical Code.
2. Double insulated tools may be used in either of the 120 volt outlets shown in the preceding illustration. (See Outlets for 2-Prong Plug.)

Extension Cords

SAFETY

- Grounded** tools require a three wire extension cord. **Double Insulated** tools can use either a two or three wire extension cord.
- As the distance from the supply outlet increases, you must use a heavier gauge extension cord. Using extension cords with inadequately sized wire causes a serious drop in voltage, resulting in loss of power and possible tool damage. **(See Table A.)**
- The smaller the gauge number of the wire, the greater the capacity of the cord. For example, a 14 gauge cord can carry a higher current than a 16 gauge cord. **(See Table A.)**
- When using more than one extension cord to make up the total length, make sure each cord contains at least the minimum wire size required. **(See Table A.)**
- If you are using one extension cord for more than one tool, add the nameplate amperes and use the sum to determine the required minimum cord size. **(See Table A.)**
- If you are using an extension cord outdoors, make sure it is marked with the suffix "W-A" ("W" in Canada) to indicate it is acceptable for outdoor use.
- Make sure the extension cord is properly wired and in good electrical condition. Always replace a damaged extension cord or have it repaired by a qualified electrician before using it.
- Protect the extension cords from sharp objects, excessive heat, and damp or wet areas.

| NAMEPLATE AMPERES (at full load) | EXTENSION CORD LENGTH | | | | |
|----------------------------------|-----------------------|-----|-----|------|------|
| | 25' | 50' | 75' | 100' | 150' |
| 0 – 2.0 | 18 | 18 | 18 | 18 | 16 |
| 2.1 – 3.4 | 18 | 18 | 18 | 16 | 14 |
| 3.5 – 5.0 | 18 | 18 | 16 | 14 | 12 |
| 5.1 – 7.0 | 18 | 16 | 14 | 12 | 12 |
| 7.1 – 12.0 | 18 | 14 | 12 | 10 | - |
| 12.1 – 16.0 | 14 | 12 | 10 | - | - |
| 16.1 – 20.0 | 12 | 10 | - | - | - |

* Based on limiting the line voltage drop to five volts at 150% of the rated amperes.

SETUP

Symbology

| | |
|--------------------------|--------------------------------------|
| | Double Insulated |
| | Volts |
| | Alternating Current |
| | Amperes |
| n ₀ xxxx/min. | No Load Revolutions per Minute (RPM) |

| | |
|--|---|
| | WARNING marking concerning Risk of Eye Injury. Wear ANSI-approved safety goggles with side shields. |
| | Read the manual before set-up and/or use. |
| | WARNING marking concerning Risk of Fire. Do not cover ventilation ducts. Keep flammable objects away. |
| | WARNING marking concerning Risk of Electric Shock. Properly connect power cord to appropriate outlet. |

OPERATION

Specifications

| | |
|---------------------------|---------------------------|
| Electrical Rating | 120VAC / 60Hz / 4.8A |
| No Load Speed | n ₀ : 3590/min |
| Grinding Wheel Dimensions | 1" x 8" with 5/8" arbor |
| Sanding Belt Size | 2" W x 28" L |

MAINTENANCE

Setup - Before Use:



Read the **ENTIRE IMPORTANT SAFETY INFORMATION** section at the beginning of this manual including all text under subheadings therein before set up or use of this product.

⚠️ WARNING

TO PREVENT SERIOUS INJURY FROM ACCIDENTAL OPERATION:

Turn the Power Switch of the tool off and unplug the tool from its electrical outlet before performing any procedure in this section.

Note: For additional information regarding the parts listed in the following pages, refer to *Parts List and Diagram* on page 14.

Mounting

1. Ensure that the Grinder/Belt Sander is always stable and secure (e.g. fixed to a bench). Select a workbench or mounting location that is able to support the weight of the Grinder/Belt Sander, plus any additional weight placed on it during use.
2. Use the mounting bolt holes provided in the Base to mount the Grinder/Belt Sander to the mounting location before use. Mounting hardware not included.

Assembly

1. Attach the Spark Arrestor (10) to the Wheel Guard (7) using two M5x10 Hex Bolt Assemblies (8).
2. Attach the Eye Shield to the Spark Arrestor bracket as shown using an M6x12 Square Neck Screw (9), Flat Washer (16), and M6 Lock Knob (17).
3. Attach the Work Rest Support (33) to the Wheel Guard using an M8x12 Lock Knob (39) and Flat Washer (94).
4. Attach the Work Rest (40) to the Work Rest Support using the M6x17 Work Rest Lock Knob (44) and Flat Washer (41). Make sure the Work Rest is perpendicular to the Grinding Wheel.

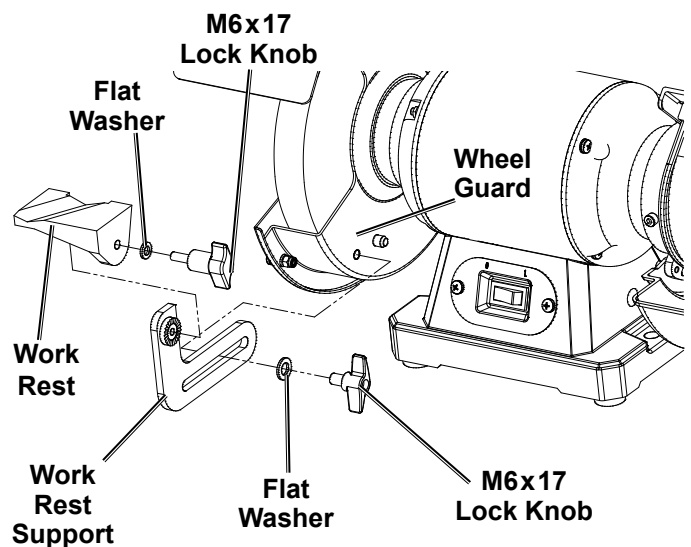
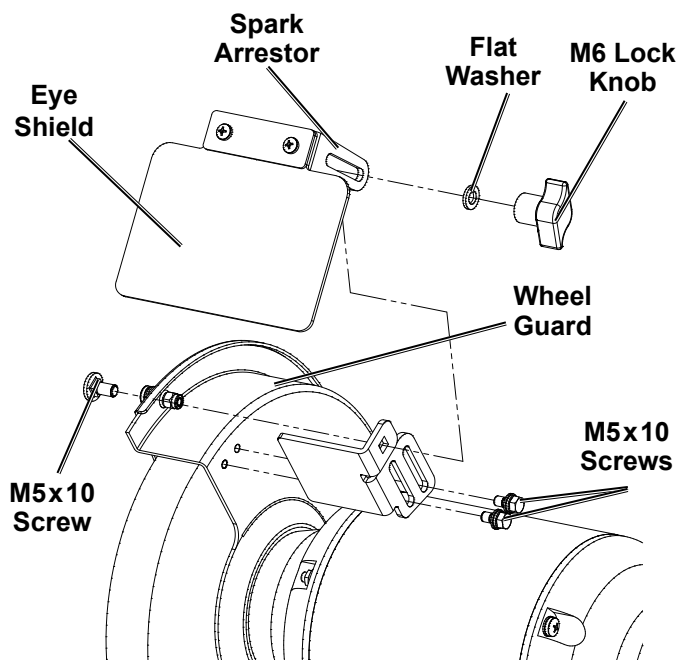

- The Work Stop (84) fits across the top of the Sanding Belt to prevent the workpiece from moving to the rear when sanding.
- Align two holes on the Work Stop with two Holes on the Sanding Belt Support Plate (75).
- Secure Work Stop in place using two M5x10 Cap Screws and Washers (80).

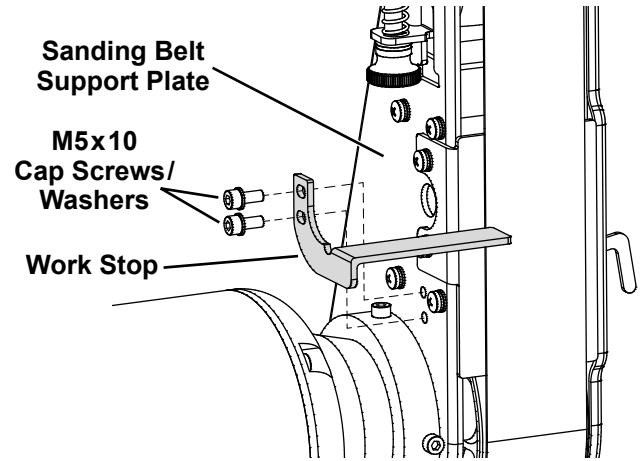

Functions

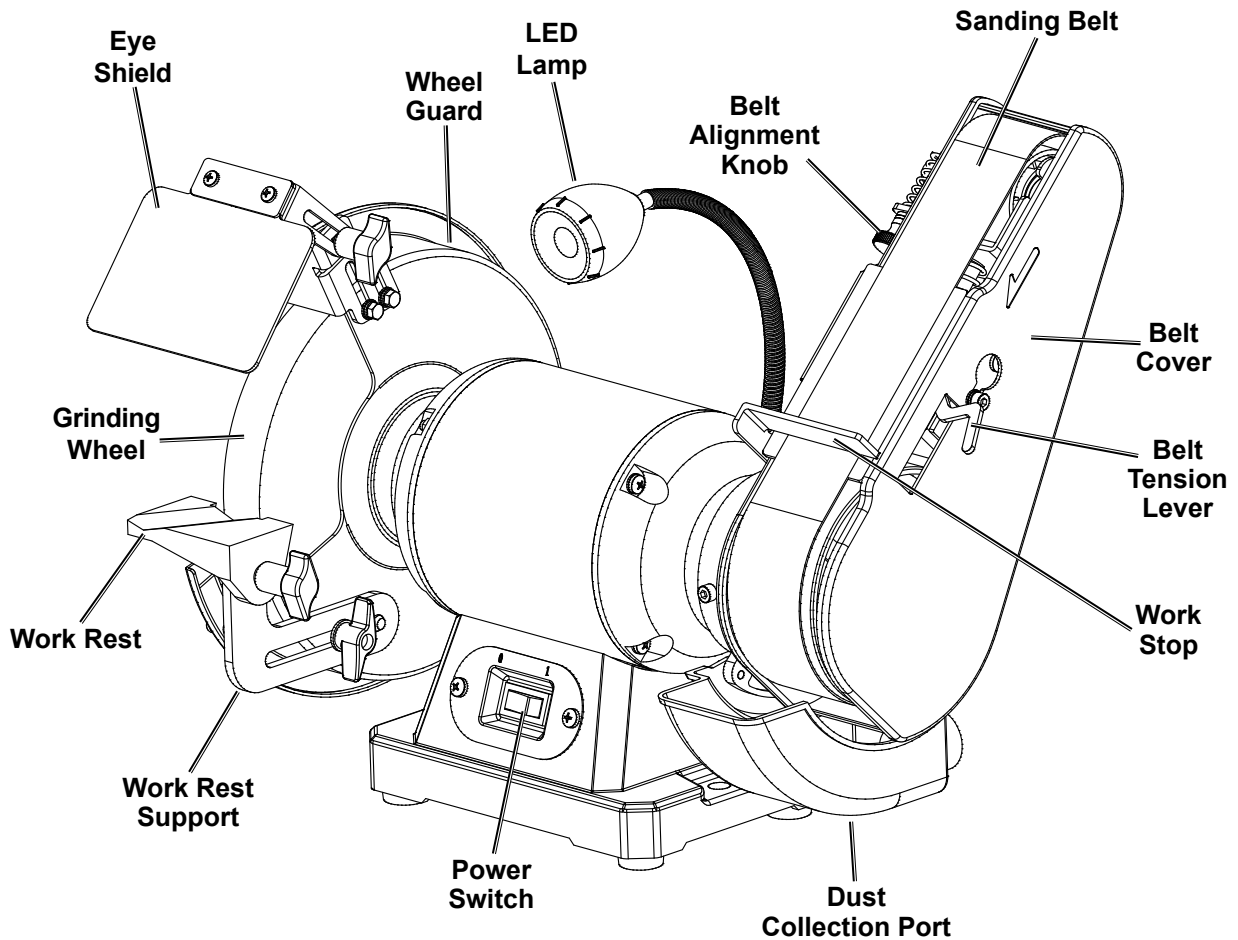

Guard Setup

- Check that the Wheel Guard and Wheel Guard Cover are in place.
- Make sure the Spark Arrestor and Eye Shield are installed and properly secured.

Dust Extraction Setup

- Connect a 1-1/4" ID hose from the Dust Collection Port to a shop vacuum or dust collection system. A hose clamp may be required. Hose, clamp and system not included.
- Periodically check the Dust Collection Port for sawdust buildup that would reduce the dust collection efficiency.

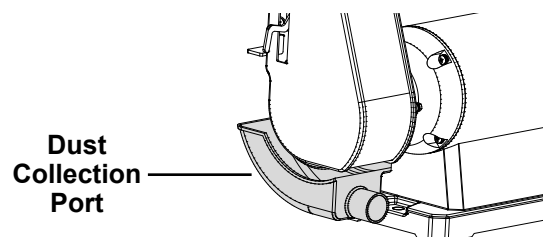

Operating Instructions



Read the **ENTIRE IMPORTANT SAFETY INFORMATION** section at the beginning of this manual including all text under subheadings therein before set up or use of this product.

Tool Changing

WARNING

TO PREVENT SERIOUS INJURY FROM ACCIDENTAL OPERATION:

Turn the Power Switch of the tool off and unplug the tool from its electrical outlet before performing any procedure in this section.

TO PREVENT SERIOUS INJURY:

DO NOT OPERATE WITH ANY GUARD DISABLED, DAMAGED, OR REMOVED.

Moving guards must move freely and close instantly.

Replacing a Grinding Wheel

1. The Grinding Wheel **MUST** be:
 - rated to at least 3580 RPM.
 - no larger than 8" (203.2mm) in diameter.
 - fitted with a 5/8" round arbor hole.
 - 1" thick.
 - suitable for edge grinding, not surface grinding.
 - dry and clean.
 - proven undamaged by inspection and by the ring-test explained below.
5. Remove the Outer Flange (4) and remove Grinding Wheel. Keep the Inner Flange in position on the Spindle.
6. Closely inspect the grinding wheel before mounting. Perform a ring-test on the wheel (unless wheel is smaller than 4" or is an unusual shape) as follows:
 - a. Suspend wheel using a dowel or finger through the arbor hole.

2. Fully loosen the Locking Screws (1) (the screws will stay in place, attached to the locking nut), turn the Wheel Guard Cover (2) counterclockwise to remove the Cover and expose the Grinding Wheel (5).
3. Place a small wooden wedge between the Grinding Wheel and Work Rest to prevent Wheel from rotating.
4. Remove the M16 Lock Nut (3) securing the Grinding Wheel by turning it clockwise with a wrench (not included).

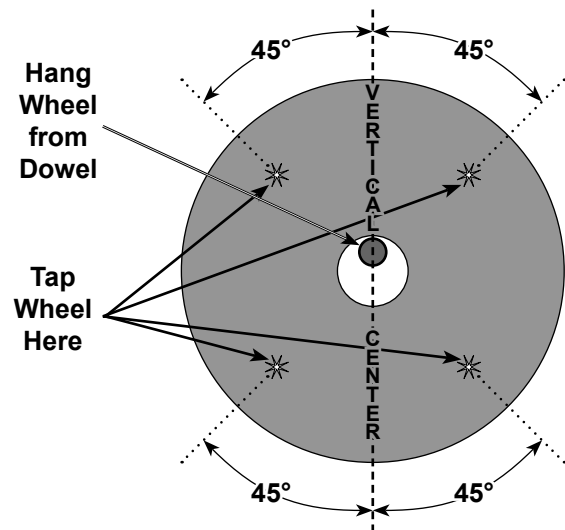
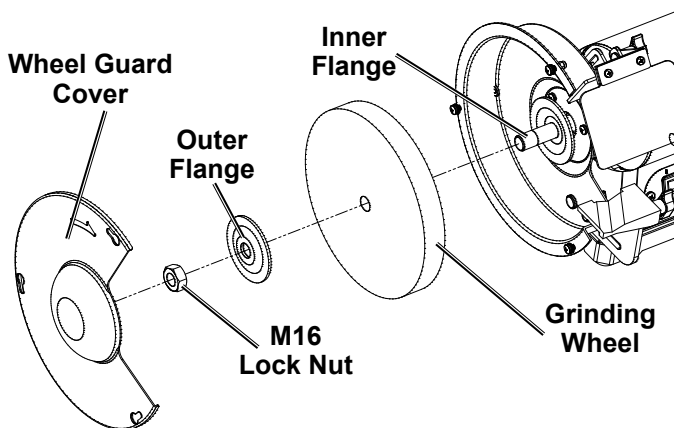

- b. Tap the flat side of the wheel with a light non-metallic object, such as a screwdriver handle, at a point 45° from the vertical center line on each side of the wheel and 1–2 inches from the edge of the wheel (see Illustration).
- c. Rotate the wheel 90° and repeat the test until the entire wheel has been checked.
- d. An undamaged wheel will give a clear tone. If cracked, there will be a dead sound and not a clear ring.

- For wheels with paper gaskets (blotters) or metal gaskets: Slip the grinding wheel onto the Spindle with the gasket first. The gasket should be centered on the grinding wheel and the wheel and gasket should rest flat against the Inner Flange.

⚠WARNING: To prevent serious injury, gaskets must be used for all grinding wheels they are provided with. Gaskets help prevent grinding wheel damage and wheel slippage, causes of wheel failure.

- Install the new grinding wheel and place the Outer Flange in position on the Spindle.
- Thread the M16 Lock Nut onto the Spindle. Wrench tighten only enough so that the wheel is securely held on the Spindle.

⚠WARNING: To prevent serious injury, do not overtighten Lock Nut. Overtightening can damage the wheel, causing wheel failure.

- Replace the Wheel Guard Cover and secure in place using the three M5x46 Screws.

Setting and Testing

⚠WARNING

TO PREVENT SERIOUS INJURY FROM ACCIDENTAL OPERATION: Make sure that the Power Switch is in the off-position and unplug the tool from its electrical outlet before performing any procedure in this section.

Adjusting Sanding Belt Tracking

- Turn the Grinder/Belt Sander on, then immediately turn off.
- The Belt should remain centered on the front and rear Drums. If the Belt starts moving to the side of either Drum, it needs to be adjusted.
- If the Belt moves towards the outside of the Sander, turn the Belt Alignment Knob slightly counterclockwise.
- If the Belt moves towards the inside of the Sander, turn the Belt Alignment Knob slightly clockwise.
- Turn the Grinder/Belt Sander on and immediately off again after adjustment to check alignment.
- If necessary, continue to adjust the Belt Alignment Knob until the Belt rides in the center of both Drums.

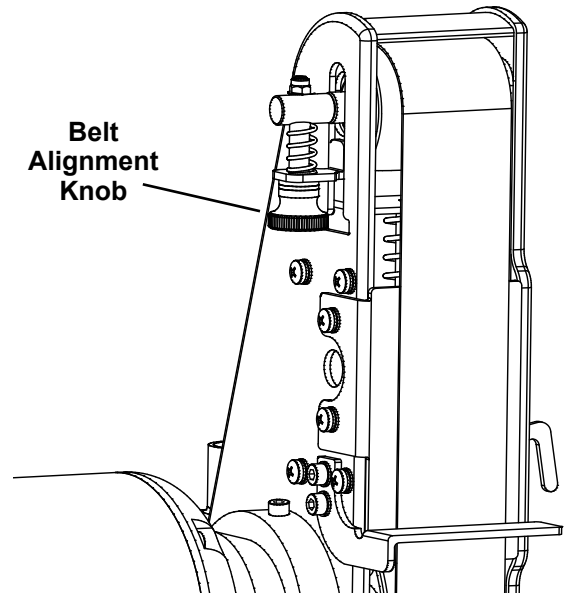

Changing Sanding Arm Position

The Sanding Arm can be used in a horizontal or vertical position or at any angle in-between from 0 to 90 degrees. To change the Sanding Arm position, do the following:

- Loosen the two M5x12 Cap Screws as shown and raise the Sanding Arm to the desired vertical position/angle.
- After positioning, wrench tighten the two Cap Screws securely to prevent the Sanding Arm from slipping.

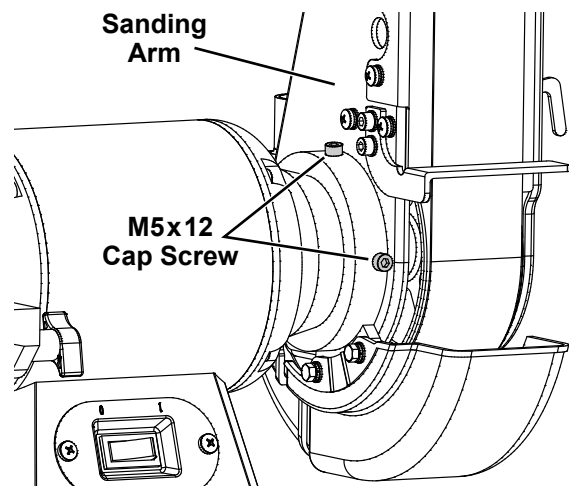

Workpiece and Work Area Set Up

1. Designate a work area that is clean and well lit. The work area must not allow access by children or pets to prevent distraction and injury.
2. Route the power cord along a safe route to reach the work area without creating a tripping hazard or exposing the power cord to possible damage. The power cord must reach the work area with enough extra length to allow free movement while working.
3. Secure loose workpieces using a vise or clamps (not included) to prevent movement while working.
4. There must not be objects, such as utility lines, nearby that will present a hazard while working.
5. Before beginning work, provide for sparks and debris that will fly off the work surface.

General Instructions for Use

Grinder General Operating Instructions

1. Make sure that the Power Switch is in the off-position, then plug in the tool.
2. Adjust the Spark Arrestor and the Work Rest frequently so as to compensate for wear of the wheel.
3. Keep the distance between the Spark Arrestor/Work Rest and the Wheel as small as possible and in any case not greater than 1/16" (0.0625"). Adjust the Work Rest so that the angle between the Work Rest and the accessory is always greater than 85°.

WARNING! Replace the worn wheel when these gaps are no longer able to be maintained. Also replace damaged or deeply grooved wheels.

WARNING! TO PREVENT SERIOUS INJURY: Always use the Wheel Guard, Work Rest, Eye Shield and Spark Arrestor as required for the accessory(ies).

4. Turn on the tool.
5. Allow the tool to come up to full speed before touching the Grinding Wheel.
6. Apply the workpiece to the Wheel, allowing the tool to operate at full speed. If the tool bogs down, use lighter pressure.

7. To create a smoother surface, keep the workpiece moving over the Wheel.

CAUTION! The tool will restart automatically if stalled.

8. To prevent accidents, turn off the tool and unplug it after use. Clean and store the tool indoors out of children's reach.

Belt Sander General Operating Instructions

1. Make sure that the Power Switch is in the off-position, then plug in the tool.
2. Make sure nothing is contacting the Sanding Belt, then turn on the Power Switch.
3. Use two hands and hold workpiece securely against the Work Stop at all times. Press the workpiece against the Belt to start sanding. Keep the workpiece moving for a better finish.
4. Occasionally check the Sanding Belt for tears, wear, or fraying. Replace used or worn sanding belts when necessary.
5. After use, turn off the tool and disconnect from the power supply. Clean and store the tool indoors out of children's reach.

Maintenance and Servicing Instructions



Procedures not specifically explained in this manual must be performed only by a qualified technician.

WARNING

TO PREVENT SERIOUS INJURY FROM ACCIDENTAL OPERATION:

Make sure that the Power Switch is in the off-position and unplug the tool from its electrical outlet before performing any procedure in this section.

TO PREVENT SERIOUS INJURY FROM TOOL FAILURE:

Do not use damaged equipment. If abnormal noise or vibration occurs, have the problem corrected before further use.

Cleaning, Maintenance, and Lubrication

- BEFORE EACH USE**, inspect the general condition of the tool. Check for:
 - loose hardware
 - misalignment or binding of moving parts
 - damaged cord/electrical wiring
 - cracked or broken parts
 - any other condition that may affect its safe operation.
- AFTER USE**, wipe external surfaces of the tool with clean cloth.
- Periodically, wear ANSI-approved safety goggles and NIOSH-approved breathing protection and blow dust and grit out of the motor vents using dry compressed air.
- WARNING! TO PREVENT SERIOUS INJURY:** If the plug or the supply cord of this power tool is damaged, it must be replaced only by a qualified service technician.

Accessory Storage and Handling

- Handle accessories carefully to prevent dropping or bumping. Do not use grinding wheels that have been dropped or bumped.
- Store accessories in shelves, racks, boxes, or drawers. Keep storage area dry and above freezing. Any grinding wheels exposed to humidity or freezing temperatures must not be used.

Sanding Belt Replacement

- Loosen the two M5x12 Cap Screws securing the Sanding Arm. Raise the Sanding Arm to the vertical position and tighten the Cap Screws.
- Remove the Sanding Belt Cover by loosening the M5x20 Cap Screw securing the Cover.
- Push the Belt Tension Lever up to release tension on the Sanding Belt.
- Slide the old Sanding Belt off the front and rear Drums.

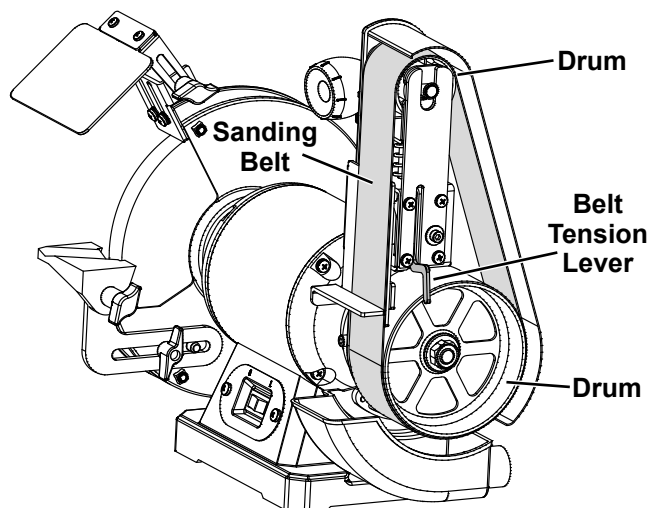
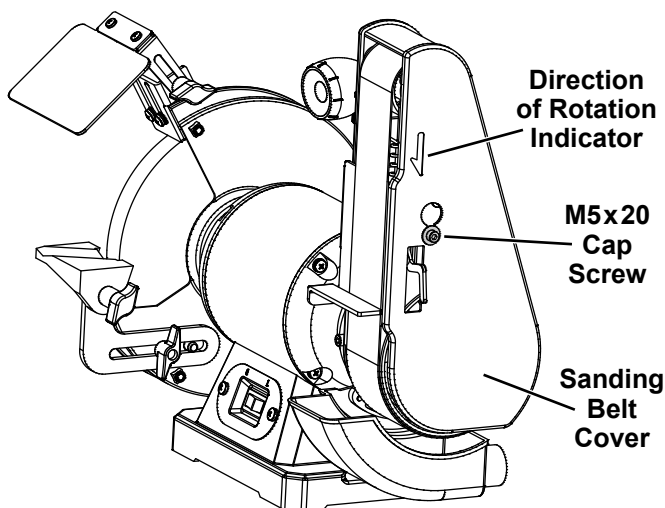

5. Slide a new 2" x 28" Sanding Belt (sold separately) onto the front and rear Drums with the directional arrows on the inside of the Belt pointing in the direction of rotation as indicated on the tool.
6. Center the Belt correctly on both Drums. Push the Tension Lever down to tighten the Belt to the Sanding Arm.
7. Replace the Sanding Belt Cover and tighten the Cap Screw securely.
8. Before using, check the new Sanding Belt for alignment. Refer to *Adjusting Sanding Belt Tracking* on page 10.

Troubleshooting

| Problem | Possible Causes | Likely Solutions |
|----------------------------------|--|--|
| Tool will not start. | <ol style="list-style-type: none"> 1. Cord not connected. 2. No power at outlet. 3. Tool's thermal reset breaker tripped (if equipped). 4. Internal damage or wear. (Carbon brushes or power switch, for example.) | <ol style="list-style-type: none"> 1. Check that cord is plugged in. 2. Check power at outlet. If outlet is unpowered, turn off tool and check circuit breaker. If breaker is tripped, make sure circuit is right capacity for tool and circuit has no other loads. 3. Turn off tool and allow to cool. Press reset button on tool. 4. Have qualified technician service tool. |
| Tool operates slowly. | <ol style="list-style-type: none"> 1. Forcing tool to work too fast. 2. Extension cord too long or cord diameter too small. 3. Applying too much pressure while grinding or sanding. | <ol style="list-style-type: none"> 1. Allow tool to work at its own rate. 2. Eliminate use of extension cord. If an extension cord is needed, use one with the proper diameter for its length and load. See <i>Extension Cords</i> on page 6. 3. Use less pressure. |
| Performance decreases over time. | Carbon brushes worn or damaged. | Have qualified technician replace brushes. |
| Excessive noise or rattling. | Internal damage or wear. (Carbon brushes or bearings, for example.) | Have qualified technician service tool. |
| Overheating. | <ol style="list-style-type: none"> 1. Forcing tool to work too fast. 2. Blocked motor housing vents. 3. Motor being strained by long or small diameter extension cord. | <ol style="list-style-type: none"> 1. Allow tool to work at its own rate. 2. Wear ANSI-approved safety goggles and NIOSH-approved dust mask/respirator while blowing dust out of motor using compressed air. 3. Eliminate use of extension cord. If an extension cord is needed, use one with the proper diameter for its length and load. See <i>Extension Cords</i> on page 6. |
| Wood burns while sanding | <ol style="list-style-type: none"> 1. Sanding Belt may be loaded with dirt or debris. 2. Applying too much pressure while sanding. | <ol style="list-style-type: none"> 1. Clean or replace Sanding Belt using instructions in this manual. 2. Use less pressure. |



**Follow all safety precautions whenever diagnosing or servicing the tool.
Disconnect power supply before service.**

Parts List and Diagram

Parts List

SAFETY

SETUP

OPERATION

MAINTENANCE

| Part | Description | Qty |
|------|---|-----|
| 1 | Philips Screw M5x46 | 3 |
| 2 | Wheel Guard Cover | 1 |
| 3 | Nut M16 | 1 |
| 4 | Wheel Flange | 2 |
| 5 | Brown Corundum Grinding Wheel | 1 |
| 6 | Philips Screw/Spring Washer M5x10 | 6 |
| 7 | Wheel Guard | 1 |
| 8 | Hex Bolt Assembly M5x10 | 2 |
| 9 | Square Neck Screw M6x12 | 1 |
| 10 | Spark Arrestor | 1 |
| 11 | Nut with Flange M4 | 2 |
| 12 | Eye Shield Bracket | 1 |
| 13 | Eye Shield | 1 |
| 14 | Eye Shield Press Plate | 1 |
| 15 | Philips Screw | 2 |
| 16 | Flat Washer | 1 |
| 17 | Lock Knob M6 | 1 |
| 18 | LED Light Assembly | 1 |
| 19 | Spring Washer | 3 |
| 20 | Philips Screw/Flat Washer M5x148 | 4 |
| 21 | Lamp Transformer | 1 |
| 22 | End Cover | 2 |
| 23 | Nut M8 | 1 |
| 24 | Wave Washer | 1 |
| 25 | Bearing 6204 | 2 |
| 26 | Stator | 1 |
| 27 | Rotor | 1 |
| 28 | Nut with Flange M5 | 4 |
| 29 | Rubber Foot | 4 |
| 30 | Philips Screw/Flat Washer M5x16 | 4 |
| 31 | Flat Washer | 1 |
| 32 | Hex Bolt/Spring Washer M8x20 | 2 |
| 33 | Work Rest Support | 1 |
| 34 | Outer Tooth Washer | 1 |
| 35 | Philips Screw/Spring Washer/Flat Washer | 2 |
| 36 | Wire Protector | 1 |
| 37 | Capacitor | 1 |
| 38 | Capacitor Bracket | 1 |
| 39 | Lock Knob M8x12 | 1 |
| 40 | Work Rest | 1 |
| 41 | Flat Washer | 1 |
| 42 | Power Cord | 1 |
| 43 | Power Cord Clip | 1 |
| 44 | Work Rest Lock Knob M6x17 | 1 |
| 45 | Switch Plate | 1 |
| 46 | Power Switch | 1 |
| 47 | Philips Screw M5x8 | 8 |
| 48 | Nut M10 | 1 |

| Part | Description | Qty |
|------|-----------------------------------|-----|
| 49 | Nut with Flange M3 | 2 |
| 50 | Plate | 1 |
| 51 | Base | 1 |
| 52 | Power Cord Clamp | 1 |
| 53 | Philips Screw M3x10 | 2 |
| 54 | Philips Screw/Spring Washer M5x10 | 4 |
| 55 | Wire Protector | 2 |
| 56 | M5 Nut | 3 |
| 57 | Drive Shaft | 1 |
| 58 | Bearing | 2 |
| 59 | Idle Pulley Drum | 1 |
| 60 | External Circlip | 1 |
| 61 | Guidance Frame Assembly | 1 |
| 62 | Compression Spring | 1 |
| 63 | Support Plate | 1 |
| 64 | Limit Board | 1 |
| 65 | Hex Socket Head Cap Bolt M5x20 | 1 |
| 66 | Belt Tension Lever | 1 |
| 67 | Sanding Belt | 1 |
| 68 | Sanding Belt Cover | 1 |
| 69 | Large Flat Washer | 4 |
| 70 | Hex Socket Head Cap Screw M5x20 | 1 |
| 71 | Nut M12 | 1 |
| 72 | Drive Pulley Drum | 1 |
| 73 | Pressure Plate | 1 |
| 74 | Knurled Nut M8 | 1 |
| 75 | Sanding Belt Support Plate | 1 |
| 76 | Rotary Table | 1 |
| 77 | Philips Screw/Spring Washer M5x16 | 3 |
| 78 | Philips Screw M4x10 | 4 |
| 79 | Dust Collection Port | 1 |
| 80 | Socket Head Cap Screw M5x10 | 2 |
| 81 | Screw Assembly M5x10 | 4 |
| 82 | Set Screw M6x6 | 3 |
| 83 | Fixed Disk | 1 |
| 84 | Work Stop | 1 |
| 85 | Workbench | 1 |
| 86 | Adjusting Spring | 1 |
| 87 | Adjusting Screw | 1 |
| 88 | Rubber Mat | 1 |
| 89 | Flat Washer | 1 |
| 90 | Hex Socket Head Cap Screw M5x12 | 2 |
| 91 | Philips Screw M4x16 | 2 |
| 92 | Light Assembly Cord Clamp | 1 |
| 93 | Cord Clip | 1 |
| 94 | Flat Washer | 1 |
| 95 | Hex Wrench | 1 |

Record Product's Serial Number Here: _____

Note: If product has no serial number, record month and year of purchase instead.

Note: Some parts are listed and shown for illustration purposes only, and are not available individually as replacement parts. Specify UPC 193175556608 when ordering parts.

Assembly Diagram

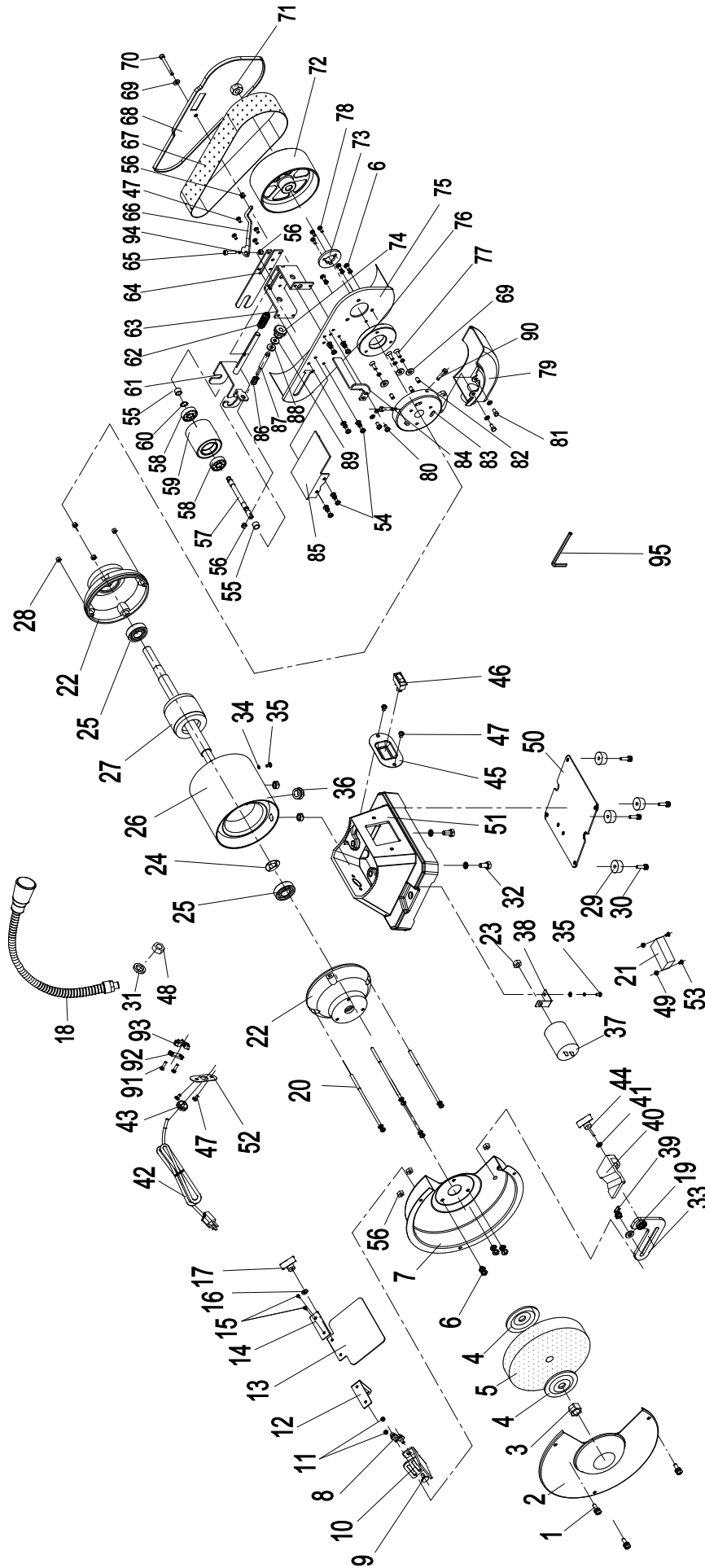

SAFETY

SETUP

OPERATION

MAINTENANCE

PLEASE READ THE FOLLOWING CAREFULLY

THE MANUFACTURER AND/OR DISTRIBUTOR HAS PROVIDED THE PARTS LIST AND ASSEMBLY DIAGRAM IN THIS MANUAL AS A REFERENCE TOOL ONLY. NEITHER THE MANUFACTURER OR DISTRIBUTOR MAKES ANY REPRESENTATION OR WARRANTY OF ANY KIND TO THE BUYER THAT HE OR SHE IS QUALIFIED TO MAKE ANY REPAIRS TO THE PRODUCT, OR THAT HE OR SHE IS QUALIFIED TO REPLACE ANY PARTS OF THE PRODUCT. IN FACT, THE MANUFACTURER AND/OR DISTRIBUTOR EXPRESSLY STATES THAT ALL REPAIRS AND PARTS REPLACEMENTS SHOULD BE UNDERTAKEN BY CERTIFIED AND LICENSED TECHNICIANS, AND NOT BY THE BUYER. THE BUYER ASSUMES ALL RISK AND LIABILITY ARISING OUT OF HIS OR HER REPAIRS TO THE ORIGINAL PRODUCT OR REPLACEMENT PARTS THERETO, OR ARISING OUT OF HIS OR HER INSTALLATION OF REPLACEMENT PARTS THERETO.

Limited 90 Day Warranty

Harbor Freight Tools Co. makes every effort to assure that its products meet high quality and durability standards, and warrants to the original purchaser that this product is free from defects in materials and workmanship for the period of 90 days from the date of purchase. This warranty does not apply to damage due directly or indirectly, to misuse, abuse, negligence or accidents, repairs or alterations outside our facilities, criminal activity, improper installation, normal wear and tear, or to lack of maintenance. We shall in no event be liable for death, injuries to persons or property, or for incidental, contingent, special or consequential damages arising from the use of our product. Some states do not allow the exclusion or limitation of incidental or consequential damages, so the above limitation of exclusion may not apply to you. THIS WARRANTY IS EXPRESSLY IN LIEU OF ALL OTHER WARRANTIES, EXPRESS OR IMPLIED, INCLUDING THE WARRANTIES OF MERCHANTABILITY AND FITNESS.

To take advantage of this warranty, the product or part must be returned to us with transportation charges prepaid. Proof of purchase date and an explanation of the complaint must accompany the merchandise. If our inspection verifies the defect, we will either repair or replace the product at our election or we may elect to refund the purchase price if we cannot readily and quickly provide you with a replacement. We will return repaired products at our expense, but if we determine there is no defect, or that the defect resulted from causes not within the scope of our warranty, then you must bear the cost of returning the product.

This warranty gives you specific legal rights and you may also have other rights which vary from state to state.

The logo for Bauer, featuring the word "Bauer" in a bold, italicized, sans-serif font. The letters are black with a white outline, and a small trademark symbol (TM) is located at the bottom right of the word.

26677 Agoura Road • Calabasas, CA 91302 • 1-888-866-5797