

# Owner's Manual & Safety Instructions

**Save This Manual** Keep this manual for the safety warnings and precautions, assembly, operating, inspection, maintenance and cleaning procedures. Write the product's serial number in the back of the manual near the assembly diagram (or month and year of purchase if product has no number). Keep this manual and the receipt in a safe and dry place for future reference.

21k

# **Bauer**<sup>TM</sup>

## **20141E-B**

### **ELECTRIC PRESSURE WASHER WITH HOSE REEL**



Visit our website at: <http://www.harborfreight.com>  
Email our technical support at: [productsupport@harborfreight.com](mailto:productsupport@harborfreight.com)

**56877**

When unpacking, make sure that the product is intact and undamaged. If any parts are missing or broken, please call 1-888-866-5797 as soon as possible.

Copyright© 2021 by Harbor Freight Tools®. All rights reserved.  
No portion of this manual or any artwork contained herein may be reproduced in any shape or form without the express written consent of Harbor Freight Tools. Diagrams within this manual may not be drawn proportionally. Due to continuing improvements, actual product may differ slightly from the product described herein.  
Tools required for assembly and service may not be included.

## **⚠ WARNING**

Read this material before using this product.  
Failure to do so can result in serious injury.  
**SAVE THIS MANUAL.**

# Table of Contents

Safety .....	3	Maintenance .....	14
Setup .....	7	Parts List and Assembly Diagram.....	18
Setup – Before Use: .....	7	Warranty .....	20
Operation.....	10		

SAFETY



SETUP

OPERATION

MAINTENANCE

WARNING SYMBOLS AND DEFINITIONS	
	This is the safety alert symbol. It is used to alert you to potential personal injury hazards. Obey all safety messages that follow this symbol to avoid possible injury or death.
	Indicates a hazardous situation which, if not avoided, will result in death or serious injury.
	Indicates a hazardous situation which, if not avoided, could result in death or serious injury.
	Indicates a hazardous situation which, if not avoided, could result in minor or moderate injury.
	Addresses practices not related to personal injury.

# IMPORTANT SAFETY INSTRUCTIONS



**WARNING - When using this product basic precautions should always be followed, including the following:**

## Safety Warnings

1. Read all the instructions before using the product.
2. To reduce the risk of injury, close supervision is necessary when a product is used near children.
3. Know how to stop the product and bleed pressures quickly. Be thoroughly familiar with the controls.
4. Stay alert – watch what you are doing.
5. Do not operate the product when fatigued or under the influence of medication, alcohol or drugs.
6. Keep operating area clear of all persons.
7. Do not overreach or stand on unstable support. Keep good footing and balance at all times.
8. Follow the maintenance instructions specified in the manual.
9. This product is provided with a ground fault circuit interrupter (GFCI) built into the power cord plug. If replacement of the plug or cord is needed, use only identical replacement parts.
10. **WARNING** – Risk of injection or injury– do not direct discharge stream at persons.
11. Connect to individual branch circuit only.
12. **WARNING** – To reduce the risk of electrocution, keep all connections dry and off the ground. Do not touch plug with wet hands.
13. Do not abuse the cord. Never use the cord for carrying, pulling or unplugging the pressure washer. Keep cord away from heat, oil, sharp edges or moving parts. Damaged or entangled cords increase the risk of electric shock.
14. **GFCI PRECAUTIONS**  
Test GFCI (Ground Fault Circuit Interrupter) before each use as follows:
  - a. Plug GFCI into power outlet and press reset button. Indicator should turn on.
  - b. Press test button. Indicator should turn off.
  - c. Press reset button again for use.

Do not use if above test fails.

The GFCI device does not protect against electrical shock due to contact with both circuit conductors or a fault in any wiring supplying the GFCI device.  
**To allow GFCI unit to function properly, EXTENSION CORDS MUST NOT BE USED with this pressure washer.**

## Set up Precautions

1. The work area should have adequate drainage to reduce the possibility of a fall or electric shock due to wet surfaces.
2. Wear ANSI-approved safety goggles during set up and use.
3. Only feed cold, clean water through this tool. Pressure washer detergent may be used in the Detergent Tank only. Do not use caustic materials, solvents, flammable materials, or detergents not designed for pressure washers. Use of any such material can cause injury, or damage this tool or personal property.
4. Prior to starting the Pressure Washer in cold weather, check all of the parts of the unit to make sure ice has not formed. Do not store the unit anywhere that the temperature will fall near 32° F (0° C).

# Operating Precautions

## SAFETY

1. Disconnect the plug from the power source before making any adjustments, changing accessories, or storing pressure washers. Such preventive safety measures reduce the risk of starting the pressure washer accidentally.
2. Do not leave the equipment unattended when it is running. Turn off the equipment before leaving the work area.
3. Wear ANSI-approved safety goggles and heavy-duty nonslip rubber work boots during use.
4. Use only accessories that are recommended by Harbor Freight Tools for your model. Accessories that may be suitable for one piece of equipment may become hazardous when used on another one.
5. This product must continuously run with cold water only. Never use hot water. Do not dry run this product. Dry running will cause serious damage to the seals.
6. To avoid electrical shock, never start and run the Pressure Washer in the rain. Never allow water to leak into the Body of the Pressure Washer. Do not direct discharge stream at the Pressure Washer itself or at other live electrical equipment.
7. Do not allow the GFCI Plug to become wet. Always place the GFCI Plug in a dry location and as far away as possible from the object being sprayed.
8. DO NOT use an extension cord with this product.
9. When using the Pressure Washer, always maintain a firm grip on the Spray Gun. Squeezing the Trigger of the Spray Gun causes a kickback force.
10. Do not feed already-pressurized water (such as that from another pressure washer) into this washer.
11. People with pacemakers should consult their physician(s) before use. Electromagnetic fields in close proximity to heart pacemaker could cause pacemaker interference or pacemaker failure.
12. Use the correct equipment for the application. Do not modify the equipment and do not use the equipment for a purpose for which it is not intended.
13. If water is leaking out of the Pressure Washer immediately turn off the unit. Unplug the Pressure Washer, and discharge all pressure before tightening fittings or having repair work done by a qualified technician.
14. The high pressure water flow can damage the work surface if not used properly. Always test the spray in an open area first.
15.  Injection Hazard. The high pressure water jet produced by this tool can cut skin or cause injury to hands or eyes. Do not allow spray to strike you and do not spray toward people or animals. Do not spray the tool itself or any electrical source.
16. This Pressure Washer is intended for outdoor residential use only.
17. **In case of an emergency during use, immediately release the trigger on the spray handle, turn the power switch off and then unplug the unit. Do not set the spray handle down without turning off the power switch.**

## SETUP

## OPERATION

## MAINTENANCE

## Vibration Hazard:

---

This tool vibrates during use. Repeated or long-term exposure to vibration may cause temporary or permanent physical injury, particularly to the hands, arms and shoulders. To reduce the risk of vibration-related injury:

1. Anyone using vibrating tools regularly or for an extended period should first be examined by a doctor and then have regular medical check-ups to ensure medical problems are not being caused or worsened from use. Pregnant women or people who have impaired blood circulation to the hand, past hand injuries, nervous system disorders, diabetes, or Raynaud's Disease should not use this tool. If you feel any medical or physical symptoms related to vibration (such as tingling, numbness, and white or blue fingers), seek medical advice as soon as possible.
2. Do not smoke during use. Nicotine reduces the blood supply to the hands and fingers, increasing the risk of vibration-related injury.
3. Wear suitable gloves to reduce the vibration effects on the user.
4. Use tools with the lowest vibration when there is a choice between different processes.
5. Include vibration-free periods each day of work.
6. To reduce vibration, maintain the tool as explained in this manual. If any abnormal vibration occurs, stop use immediately.

## Service Precautions

---

### Ground Fault Circuit Interrupter Protection

---

This pressure washer is provided with a ground-fault circuit-interrupter (GFCI) built into the plug of the power-supply cord. This device provides additional protection from the risk of electric shock. Should replacement of the plug or cord become necessary, use only identical replacement parts that include GFCI protection.

### Servicing a Double-Insulated Appliance

---



In a double-insulated product, two systems of insulation are provided instead of grounding. No grounding means is provided on a double-insulated product, nor should a means for grounding be added to the product. Servicing a double-insulated product requires extreme care and knowledge of the system, and should be done only by qualified service personnel. Replacement parts for a double-insulated product must be identical to the parts they replace. A double-insulated product is marked with the words "DOUBLE INSULATION" or "DOUBLE INSULATED." The symbol  may also be marked on the product.





**SAVE THESE INSTRUCTIONS.**

# Symbology

SAFETY

	Double Insulated
<b>VAC</b>	Volts Alternating Current
<b>A</b>	Amperes
	WARNING marking concerning Risk of Eye Injury. Wear ANSI-approved safety goggles with side shields.

	Read the manual before set-up and/or use.
	WARNING marking concerning Risk of Electric Shock. Properly connect power cord to appropriate outlet.
	WARNING marking concerning Risk of Injection. Do not direct spray at any person or animal.

## Specifications

SETUP

Electrical Rating	120VAC / 60Hz / 14A
Maximum Pressure	2000 PSI
Maximum Flow Rate	1.2 GPM
Maximum Water Temperature	104°F
Maximum Inlet Water Pressure	101.5 PSI
High-Pressure Hose	25 ft
Power Cord	35 ft GFCI
Pump Type	3-piston axial cam
Detergent Tank Size	0.6 Gal
Wheel Size	10" Dia.
Weight	32 lb

OPERATION

MAINTENANCE

# ***Bauer***<sup>™</sup>

## Setup – Before Use:



Read the **ENTIRE IMPORTANT SAFETY INFORMATION** section at the beginning of this manual including all text under subheadings therein before set up or use of this product.

## **⚠️ WARNING**

**TO PREVENT SERIOUS INJURY FROM ACCIDENTAL OPERATION:**

Turn the Power Switch of the tool off, unplug the tool from its electrical outlet, shut off the water supply and safely discharge all residual water pressure from the unit before assembling or making any adjustments to the tool.

## Functions



# Assembly

**Note:** For additional information regarding the parts listed in the following pages, refer to *Parts List and Assembly Diagram* on page 18.

Remove shipping caps from Water Inlet/Outlet.

## Attach Wheels

1. Insert Wheel Axle (37) through Wheel (36).
2. Insert Axle on Wheel through hole in Lower Frame (27).
3. Place Washer (35) over end of Axle and secure it in place with an R-Pin (34).
4. Repeat the previous steps for the other Wheel.

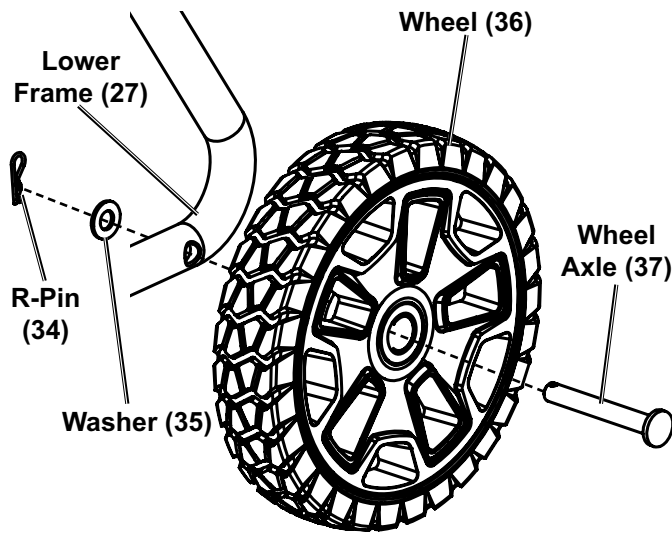

## Attach Handle

1. Hold the Spring Button (45) near each end of Handle (1) in while inserting the ends into Lower Frame (27).

**CAUTION!** Be careful to avoid pinching your hands.

2. Slide Handle into Lower Frame until both Spring Buttons pop out into place.

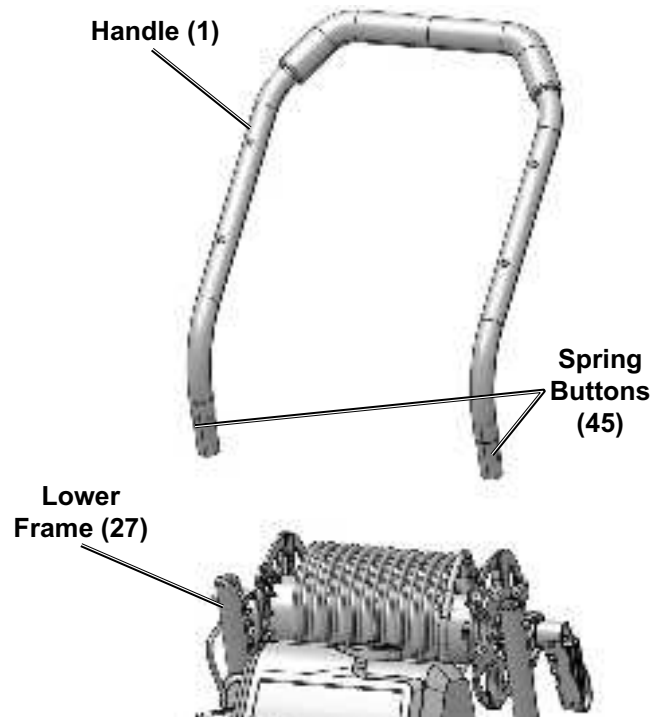

## Attach Gun Holder

1. Position Gun Holder (3) against left side of Handle (1) as shown.
2. Align holes in Gun Holder with holes in Handle.
3. Attach Gun Holder to Handle with two Screws (4).

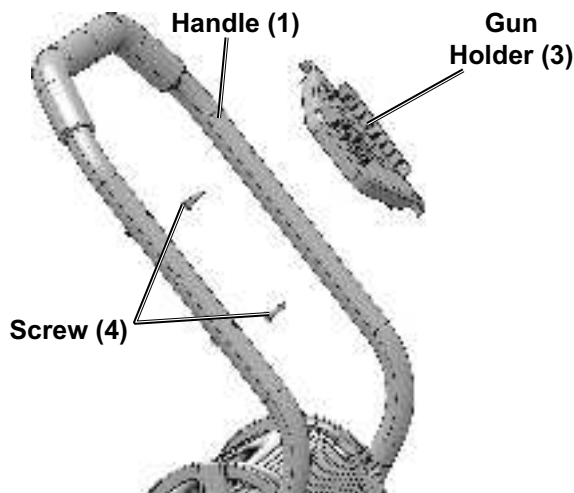

## Attach Storage Panel and Cord Hook

1. Position the Storage Panel (6) against right side of Handle (1) as shown.
2. Align holes in the Storage Panel with holes in the Handle.
3. Attach the Storage Panel to the Handle with two Screws (4).
4. Place the Cord Hook Bracket (11) against the right edge of the Handle, aligning it with the hole.
5. Place the Cord Hook (12) over its Bracket with the end pointing upwards.
6. Secure the Cord Hook to the Bracket and Handle using the Cord Hook Screw (13).

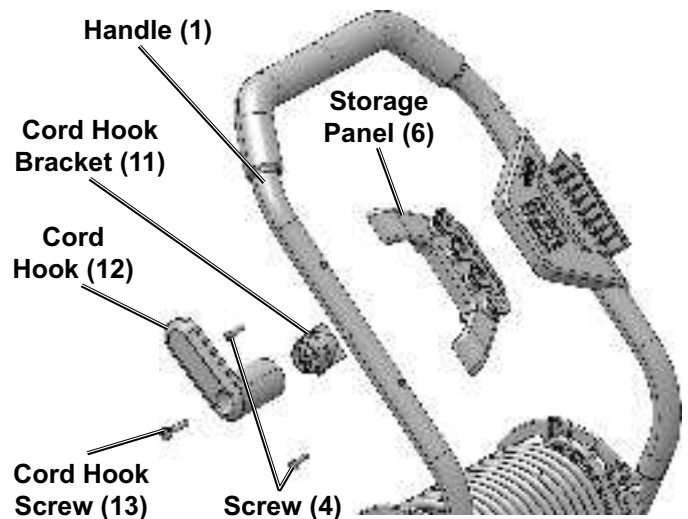

## Connect High-Pressure Hose

1. Connect High-Pressure Hose (41) to connection on back of Pressure Washer by pushing Hose in as far as it will go, then threading coupler on tightly.
2. Connect High-Pressure Hose to connection under Gun Handle (61) by pushing Hose in as far as it will go, then threading coupler on tightly.

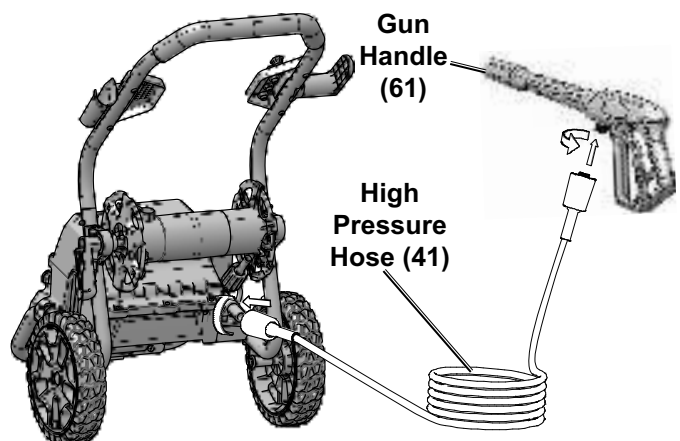

## Operating Instructions



Read the **ENTIRE IMPORTANT SAFETY INFORMATION** section at the beginning of this manual including all text under subheadings therein before set up or use of this product.

### Work Piece and Work Area Set Up

1. Designate a work area that is clean and well-lit. The work area must not allow access by children or pets to prevent distraction and injury.
2. CHECK THE WATER SUPPLY. Prior to using the Pressure Washer for the first time, it is ESSENTIAL to verify that the water supply is adequate. The Pressure Washer needs TWICE the water supply (or volume) of the listed water output (1.2 GPM). This Pressure Washer will need about 2.4-3 GPM to operate correctly and efficiently. If the water is being supplied by a well/pump, make certain that the well/pump produces enough water to keep up with the Pressure Washer's water demands. Water supply hoses should be heavy-duty. The flow rate of the water supply must never be allowed to fall below 2.4 GPM. To determine the water supply's flow rate: Run the water at full for 30 seconds into a 5 gallon container, then measure the amount of water in the container and multiply by 2.
3. USE PROPER ELECTRICAL SUPPLY. This unit uses a large amount of current, especially during start-up. Turn off power switch, then connect this unit only to a dedicated household circuit with no additional loads (running devices) connected to it. For best results, use the outlet that is nearest to the circuit breaker panel.
4. PLAN OUT THE JOB Plan out areas to be cleaned, how many sessions will be necessary, and how long the individual sessions will need to be. Plan to clean the higher areas first. Plan a safe direction for runoff, and plan on working your way in that direction.
5. Clear the area of all objects that are not being cleaned. If any water-sensitive or delicate items cannot be moved, cover them. If detergent is to be used, cover or remove any plants or animals. Disconnect power to and protect any nearby electrical wiring. Close windows and doors.
6. Place the Pressure Washer in a location which is protected from runoff. The location should be close enough so that the water supply hose will reach every portion of the area with some slack for movement.
7. Route the power cord along a safe route to reach the work area without creating a tripping hazard or exposing the power cord to possible damage. The power cord must reach the work area with enough extra length to allow free movement while working.

**CAUTION!** If the Pressure Washer is run with an inadequate water supply, the pump may cavitate. Cavitation causes the pump to operate loudly and will damage it.

## Tool Set Up

### **⚠️WARNING**

#### **TO PREVENT SERIOUS INJURY FROM ACCIDENTAL OPERATION:**

Turn the Power Switch off, unplug it from its electrical outlet, and relieve all pressure before making adjustments or installing accessories.

1. MAKE SURE THE WATER INLET STRAINER AND WAND ARE FREE OF MINERAL BUILDUP OR DEBRIS.
2. Insert Wand into end of Spray Gun, press in and twist Wand clockwise until it locks into place.



3. Run water through water supply hose (not included) to remove any debris. Turn off water.

4. Connect water supply hose to Water Inlet on front of Pressure Washer. Tighten securely.

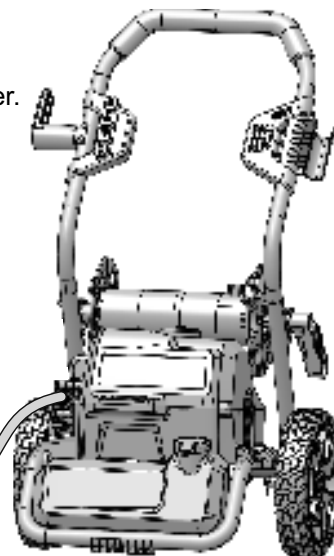
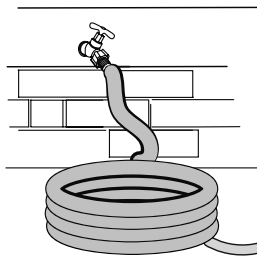

5. Nozzle Selection:
  - This Pressure Washer includes several Nozzles with different spray patterns. Select the Nozzle that suits your requirements.

#### **CAUTION! TO PREVENT INJURY AND PROPERTY DAMAGE, USE HIGH-IMPACT SPRAY WITH CAUTION.**

- The Black Nozzle is used specifically for dispensing detergent at lower pressure.
- Pull back on the collar at the end of the Wand, insert the Nozzle, and release the collar so that it holds the Nozzle securely in place.

# General Operating Instructions

SAFETY

**⚠ WARNING** TO PREVENT ELECTRIC SHOCK AND DEATH: Test Ground Fault Circuit Interrupter (GFCI) before each use. The GFCI does not protect against electrical shock due to contact with both circuit conductors or a fault in any wiring supplying this device. Do not alter or disable the GFCI. Do not use an extension cord.

This unit is intended for light to moderate cleaning. It is not intended for paint stripping or deep concrete cleaning.

1. Uncoil High-Pressure Hose completely. **Do not use Pressure Washer if Hose is kinked or looped.**
2. The Spray Gun includes a trigger safety lock.
  - Swing the trigger safety lock flat against the back side of the trigger right before spraying.
  - Swing the trigger safety lock out to engage the handle of the Spray Gun after use.
5. Turn on water supply.
6. Turn Power Switch to ON position.

**Note:** If the unit does not turn on or turns off suddenly, turn Power Switch to OFF position, then check and reset the GFCI.

**NOTICE:** Pressure Washer will run **only** while Trigger is pressed. When trigger is released, Pump will turn off. **Do not leave idle for more than one minute without spraying.**

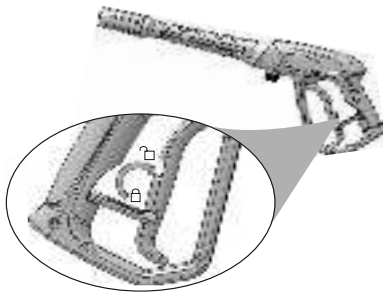

3. Point Spray Gun in safe direction, press Trigger to release all pressure, then release Trigger.
4. Plug GFCI into dedicated, grounded 120V outlet, then:
  - a. Press **RESET** button. Indicator should light up.
  - b. Press **TEST** button. Indicator should turn off.
  - c. Press **RESET** button again. Indicator should light up, unit is ready for use.

7. **Test spray an inconspicuous area:**
  - a. Set Nozzle to low-impact fan spray.
  - b. Point Spray Gun at 45° angle to test area. Release trigger safety lock, then press Trigger. **Be aware of kick back.**
  - c. Spray test area, adjusting pressure, as needed, by changing distance from surface and/or adjusting Nozzle.
  - d. If using detergent:
    - Turn off unit, remove Wand, fill Detergent Tank, then attach Detergent Tank.
    - Turn on unit, then spray area with detergent according to detergent manufacturer's instructions. Scrub surface as necessary.
    - Turn off unit, remove Detergent Tank, then attach Wand.
    - Set Nozzle to low-impact fan spray.
    - Turn on unit, then spray area to rinse off detergent, adjusting pressure, as needed, by changing distance from surface and/or adjusting Nozzle.
  - e. Inspect test area for damage or discoloration.

SETUP

OPERATION

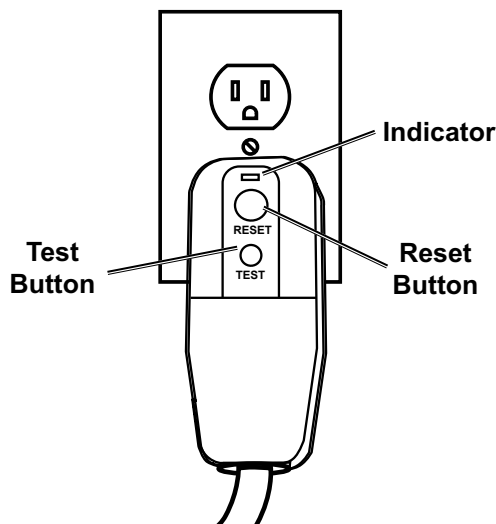

MAINTENANCE

## Cleaning Windows

- a. Inspect caulking and/or glazing. Inspect trim.  
**DO NOT PRESSURE WASH WINDOWS IF CAULKING/GLAZING/TRIM IS NOT INTACT.**
- b. If needed, apply detergent according to manufacturer's instructions.
- c. Set Nozzle to low-impact fan spray.  
**DO NOT USE HIGH-IMPACT SPRAY, FORCE MAY BREAK GLASS.**
- d. Point Spray Gun at 45° angle to, and 4 feet away from, window. Spray window.

## Cleaning Wood

**DO NOT CLEAN WOOD THAT IS HOT OR IN DIRECT SUNLIGHT.**

- a. If needed, apply wood cleaning detergent according to manufacturer's instructions. For vertical surfaces, apply detergent from bottom to top.
- b. Scrub stained areas as needed.
- c. Set Nozzle to low-impact fan spray.
- d. Point Spray Gun at 45°. Spray surface, working with the grain of the wood.
- e. Let surface dry completely, then apply stain or sealer, as needed, according to manufacturer's instructions.

## Cleaning Brick and Mortar

- a. Inspect mortar, patching as needed. Let mortar cure according to manufacturer's instructions.
- b. Soak surface prior to applying detergent.
- c. If needed, apply brick cleaning detergent according to manufacturer's instructions. For vertical surfaces, apply detergent from bottom to top.
- d. Scrub stained areas as needed.
- e. Set Nozzle to low-impact fan spray.

**TO PREVENT DAMAGE, ONLY USE LOW-IMPACT SETTING.**

- f. Point Spray Gun at 45°. Spray surface.
- g. Let surface dry completely, then apply sealer, as needed, according to manufacturer's instructions as needed.

8. When finished:
  - Release Trigger, then set Trigger Safety Lock.
  - Turn off Power Switch.
  - Turn off water supply.
  - Unplug the unit.
  - Point Nozzle in safe direction, press Trigger to release all pressure, then release Trigger.
  - Disconnect water supply hose.
  - Disconnect High-Pressure Hose from unit.
  - Disconnect High-Pressure Hose from Spray Gun.

## 9. **IMPORTANT: CLEAN THE NOZZLES AFTER EVERY USE TO MAINTAIN SPRAYING POWER AND PREVENT PUMP DAMAGE.**

- Remove Wand from Spray Gun.
- Remove Nozzle from Wand by turning Nozzle clockwise.
- Push Nozzle Tip Cleaner into tip to push out debris and buildup.
- Remove Nozzle Tip Cleaner and back-flush water through Nozzle.
- Reattach Nozzle to Wand.
- Clean and store according to **User-Maintenance Instructions on page 14.**

## User-Maintenance Instructions

### **⚠️ WARNING**

#### **TO PREVENT SERIOUS INJURY FROM ACCIDENTAL OPERATION:**

Turn the Power Switch of the tool off, unplug the tool from its electrical outlet, shut off the water supply and safely discharge all residual water pressure from the unit before performing any inspection, maintenance, or cleaning procedures.

#### **TO PREVENT SERIOUS INJURY FROM TOOL FAILURE:**

Do not use damaged equipment. If abnormal noise or vibration occurs, have the problem corrected before further use.

## Cleaning, Maintenance, and Lubrication

- BEFORE EACH USE**, inspect the general condition of the tool. Check for:
  - loose hardware,
  - misalignment or binding of moving parts,
  - damaged cord/electrical wiring,
  - damaged high-pressure hose/accessories,
  - cracked or broken parts, and
  - any other condition that may affect its safe operation.
- AFTER USE:**
  - Drain water by tipping the unit. Frost will damage the unit if it contains water.
  - Flush Detergent Tank with water.
  - Use only a clean cloth and mild detergent to clean the body of the Pressure Washer. Do not use solvents.
- PERIODICALLY**, remove mineral buildup. Unplug the unit and lay it face down. Fill Water Inlet with de-mineralizing solution, following solution manufacturer's instructions. Drain de-mineralizing solution out of Water Inlet and rinse out inlet thoroughly before use.
- ⚠️ WARNING! TO PREVENT SERIOUS INJURY: If the supply cord or GFCI unit of this power tool is damaged, it must be replaced only by a qualified service technician.**
  - Do not immerse any part of the tool in liquid.
  - Dry off any remaining water on all parts and fittings.
  - Remove mineral deposits from the nozzle using a thin, stiff wire brush.

## Storage

- Place accessories, High-Pressure Hose and Power Cord in their storage locations.
- Store in a dry, frost-free room. Flush the unit with automotive antifreeze prior to long-term storage. Dispose of antifreeze according to local ordinances.

# Troubleshooting

Problem	Possible Causes	Likely Solutions
Pressure Washer will not start	<ol style="list-style-type: none"> <li>1. Cord not connected.</li> <li>2. No power at outlet.</li> <li>3. GFCI circuit breaker tripped.</li> <li>4. Internal damage or wear. (Carbon brushes or switch, for example.)</li> </ol>	<ol style="list-style-type: none"> <li>1. Check that cord is plugged in.</li> <li>2. Check power at outlet. If outlet is unpowered, turn off tool and check circuit breaker. If breaker is tripped, make sure circuit is right capacity for tool and circuit has no other loads.</li> <li>3. Press reset button on GFCI unit on cord.</li> <li>4. Have a qualified technician service tool.</li> </ol>
Pressure Washer stops suddenly	<ol style="list-style-type: none"> <li>1. GFCI circuit breaker tripped.</li> <li>2. Water leaking from housing.</li> </ol>	<ol style="list-style-type: none"> <li>1. Press reset button on GFCI unit on cord.</li> <li>2. <b>SHOCK HAZARD! IMMEDIATELY</b> discontinue use. Have the unit repaired by a qualified technician before further use.</li> </ol>
Output pressure varies	<ol style="list-style-type: none"> <li>1. Not enough water supply.</li> <li>2. Air in water supply.</li> <li>3. Water Inlet Filter is clogged.</li> <li>4. Nozzle not attached to Spray Gun.</li> <li>5. Nozzle is clogged.</li> <li>6. Nozzle has mineral build up.</li> <li>7. Water supply hose is too long or narrow.</li> <li>8. Internal valves or seals may be worn or sticking.</li> </ol>	<ol style="list-style-type: none"> <li>1. Check water supply hose for kinks, leaks, or blockage. Open faucet all the way.</li> <li>2. Check that all connections are tight.</li> <li>3. Remove Filter and clean.</li> <li>4. Pressure is created by the Nozzle, not the Spray Gun. Attach Nozzle to Spray Gun.</li> <li>5. Remove Nozzle and clean with Nozzle Tip Cleaner.</li> <li>6. Remove Nozzle and clean with de-mineralizing solution.</li> <li>7. Shorten the length of the water supply hose if needed to increase pressure.</li> <li>8. Have a qualified technician service tool.</li> </ol>
Trigger does not depress	Safety lock is still engaged.	Press Trigger Safety Lock on the bottom of the Spray Gun to release the Safety Lock.
Detergent will not dispense	Incorrect detergent type.	Check that the detergent is the recommended type of detergent. Clean out dispenser and replace with correct type if needed.
Performance decreases over time	Clogged with mineral deposits.	Clean unit with de-mineralizing solution.



**Follow all safety precautions whenever diagnosing or servicing the tool. Disconnect power supply before service.**

## PLEASE READ THE FOLLOWING CAREFULLY

---

SAFETY

THE MANUFACTURER AND/OR DISTRIBUTOR HAS PROVIDED THE PARTS LIST AND ASSEMBLY DIAGRAM IN THIS MANUAL AS A REFERENCE TOOL ONLY. NEITHER THE MANUFACTURER OR DISTRIBUTOR MAKES ANY REPRESENTATION OR WARRANTY OF ANY KIND TO THE BUYER THAT HE OR SHE IS QUALIFIED TO MAKE ANY REPAIRS TO THE PRODUCT, OR THAT HE OR SHE IS QUALIFIED TO REPLACE ANY PARTS OF THE PRODUCT. IN FACT, THE MANUFACTURER AND/OR DISTRIBUTOR EXPRESSLY STATES THAT ALL REPAIRS AND PARTS REPLACEMENTS SHOULD BE UNDERTAKEN BY CERTIFIED AND LICENSED TECHNICIANS, AND NOT BY THE BUYER. THE BUYER ASSUMES ALL RISK AND LIABILITY ARISING OUT OF HIS OR HER REPAIRS TO THE ORIGINAL PRODUCT OR REPLACEMENT PARTS THERETO, OR ARISING OUT OF HIS OR HER INSTALLATION OF REPLACEMENT PARTS THERETO.

SETUP

OPERATION

MAINTENANCE

The logo for Bauer, featuring the word "Bauer" in a bold, italicized, sans-serif font. The letters are black with a white outline, and a small trademark symbol (TM) is located at the bottom right of the word.

**Record Product's Serial Number Here:** \_\_\_\_\_

**Note:** If product has no serial number, record month and year of purchase instead.

**Note:** Some parts are listed and shown for illustration purposes only, and are not available individually as replacement parts. Specify UPC 193175444196 when ordering parts.

SAFETY

SETUP

OPERATION

MAINTENANCE



## Parts List and Assembly Diagram

### Parts List

Part	Description	Qty
1	Upper Handle	1
2	Foam Grip	1
3	Gun Holder Assembly	1
4	Screw	4
5	Screw	9
6	Nozzle Storage Panel Assembly	1
7	0° Nozzle	1
8	25° Nozzle	1
9	40° Nozzle	1
10	Soap Nozzle	1
11	Power Cord Arm Retainer	1
12	Power Cord Arm	1
13	Screw	1
14	Power Cord	1
15	Cord Clamp	1
16	Ground Fault Circuit Interrupter	1
17	Motor Housing	1
18	U Clip	2
19	Water Inlet Connector Assembly	1
20	Left Frame Pad	1
21	Right Frame Pad	1
22	Hose Reel Bracket	2
23	Screw	2
24	Cord Clamp	1
25	Screw	4
26	Lower Housing	1
27	Lower Frame	1
28	Nut	4
29	Detergent Tank Cap	1
30	Detergent Tank	1
31	Suction Hose 30cm	1
32	Screw	8

Part	Description	Qty
33	Bracket Foot Pad	1
34	R-Clip	2
35	Washer	2
36	Wheel	2
37	Wheel Axle	2
38	Screw	1
39	Hose Reel Handle Assembly	1
40	Hose Reel Assembly	1
41	High Pressure Hose	1
42	Motor Bracket	1
43	Screw	12
44	Motor Pump Assembly	1
45	Spring Button	2
46	Pump Holder Bushing	2
47	O-Ring	1
48	Water Outlet Connector	1
49	Water Outlet Retaining Plate	1
50	Screw	2
51	Upper Housing	1
52	Gun Valve Cover	1
53	Connection Terminal	1
54	Switch Box	1
55	Screw	2
56	Switch	1
57	Switch Lever	1
58	O-Ring	1
59	Switch Box Cover	1
60	Screw	4
61	Gun Handle	1
62	Gun Wand	1
63	Nozzle Tip Cleaner	1
64	Switch Knob	1

SAFETY

SETUP

OPERATION

MAINTENANCE

# Assembly Diagram

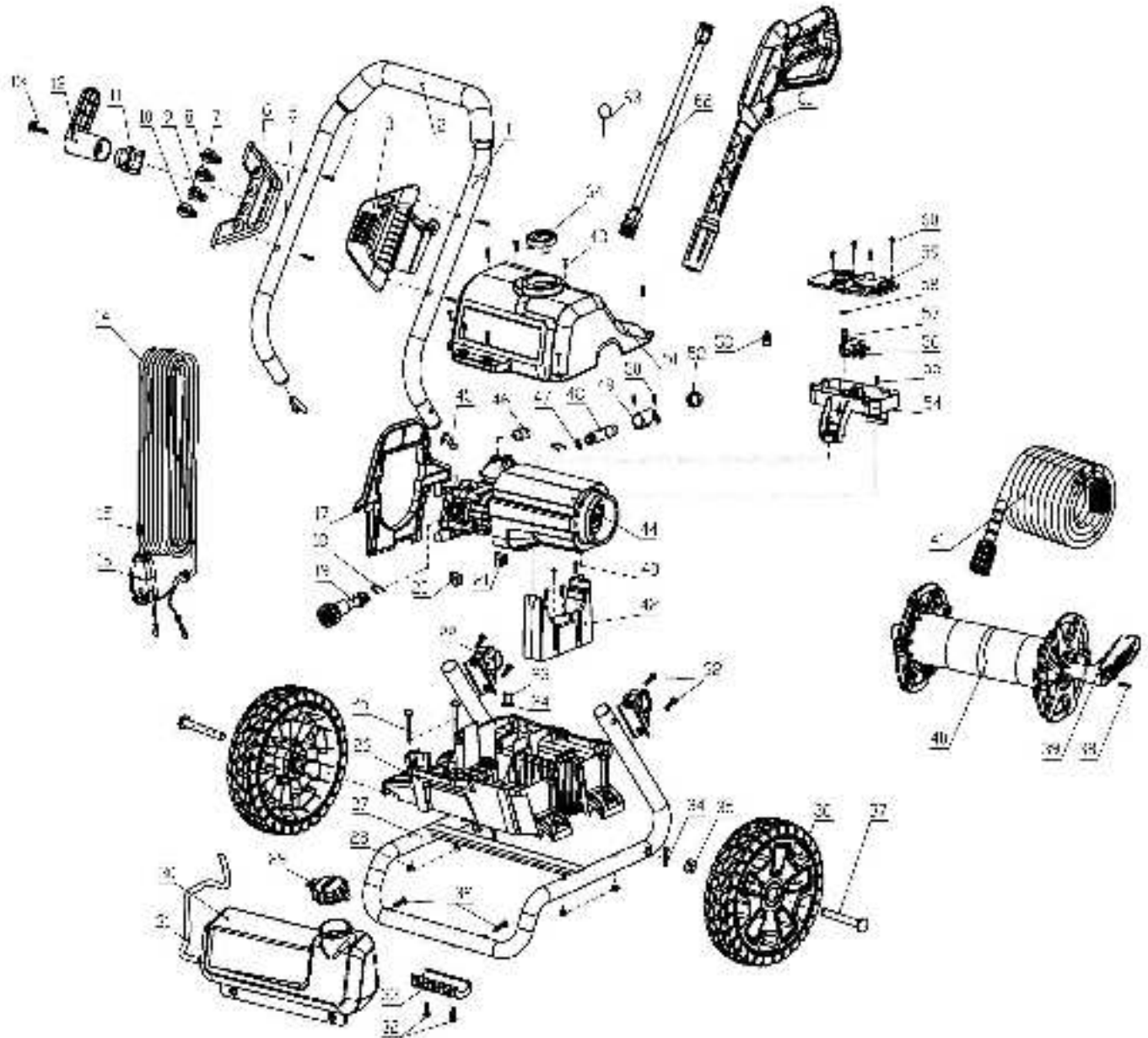

SAFETY

SETUP

OPERATION

MAINTENANCE

## Limited 90 Day Warranty

Harbor Freight Tools Co. makes every effort to assure that its products meet high quality and durability standards, and warrants to the original purchaser that this product is free from defects in materials and workmanship for the period of 90 days from the date of purchase. This warranty does not apply to damage due directly or indirectly, to misuse, abuse, negligence or accidents, repairs or alterations outside our facilities, criminal activity, improper installation, normal wear and tear, or to lack of maintenance. We shall in no event be liable for death, injuries to persons or property, or for incidental, contingent, special or consequential damages arising from the use of our product. Some states do not allow the exclusion or limitation of incidental or consequential damages, so the above limitation of exclusion may not apply to you. THIS WARRANTY IS EXPRESSLY IN LIEU OF ALL OTHER WARRANTIES, EXPRESS OR IMPLIED, INCLUDING THE WARRANTIES OF MERCHANTABILITY AND FITNESS.

To take advantage of this warranty, the product or part must be returned to us with transportation charges prepaid. Proof of purchase date and an explanation of the complaint must accompany the merchandise. If our inspection verifies the defect, we will either repair or replace the product at our election or we may elect to refund the purchase price if we cannot readily and quickly provide you with a replacement. We will return repaired products at our expense, but if we determine there is no defect, or that the defect resulted from causes not within the scope of our warranty, then you must bear the cost of returning the product.

This warranty gives you specific legal rights and you may also have other rights which vary from state to state.

The logo for Bauer, featuring the word "Bauer" in a bold, italicized, sans-serif font. The letters are black with a white outline, and a small trademark symbol (TM) is located at the bottom right of the letter "r".

26677 Agoura Road • Calabasas, CA 91302 • 1-888-866-5797