

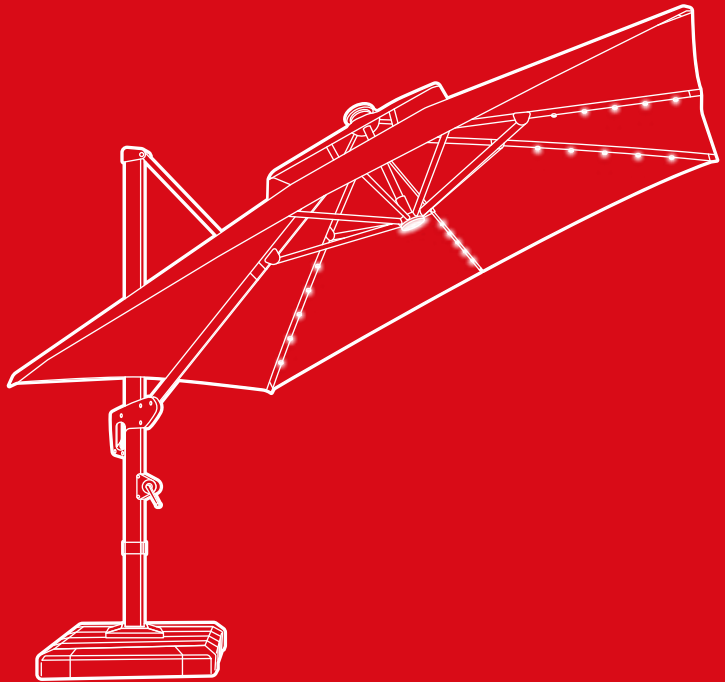

BEST CHOICE
PRODUCTS



INSTRUCTION MANUAL

2-Tier Square LED Cantilever
Umbrella with Fillable Base

SKY6467 + SKY6468 + SKY6469 + SKY6470 + SKY6471 + SKY6472
SKY6703 + SKY6704 + SKY6705 + SKY6706

Ver. 4





Solar panel requires
6 to 7 hours of
direct sunlight to
fully charge.



Do not use without
umbrella base weights.
Recommended Weight:
>200 lbs.

bestchoiceproducts.com

! NOTICE

Please retain these instructions for future reference.

- For residential use only.
- Umbrella base weights are not included. Do not use without umbrella base weights (recommended weight: >200 lbs.).
- Place umbrella on a stable and level surface.
- Umbrella is suitable for rain showers and light wind.
- Do not use umbrella in inclement weather, such as snow, heavy rain, thunderstorms, or strong wind.
- Firmly secure all bolts, screws and knobs before use.
- Reconfirm that all bolts, screws, and knobs are secure every 90 days.
- Fasten screws loosely during initial assembly. Do not firmly tighten the screws until the item is completely assembled.
- Be aware that some parts are heavy and have sharp edges.
- If any parts are missing, broken, damaged, or worn, stop using this product until repairs are made and/or factory replacement parts are installed.
- Do not use this item in a way inconsistent with the manufacturer's instructions as this could void the product warranty.

BATTERY WARNINGS

The following safety hazards may result in serious injury or death:

- Do not mix alkaline, standard (Carbon Zinc) and rechargeable (Nickel Cadmium, Nickel Metal Hydride, or Lithium Ion) batteries.
- To optimize lifespan, remove battery from product if it will not be used for an extended period of time.
- Do not mix old and new batteries.
- Do not attempt to charge non-rechargeable batteries as this may result in rupture or leakage and cause personal injury or property damage.
- Battery installation, replacement, or charging should be handled by adults.
- Exhausted batteries should be removed and disposed of in accordance with local, state, and federal regulations.
- The supply terminals should not be short-circuited.
- Do not put batteries next to or in a heat source (fire, electronic heating device, etc.)
- Do not hit batteries against hard objects.
- Do not submerge batteries in water.
- Batteries should be inserted with the correct polarity (+ -).

TOOLS REQUIRED



S10 ALLEN WRENCH
(PROVIDED)



S5 ALLEN WRENCH
(PROVIDED)



2 PERSON
ASSEMBLY



UP TO 30 MIN.
ASSEMBLY

HARDWARE

1

M6 x 9mm
BOLT



1 PC

2

M10 x 25mm
SCREW



4 PCS

3

M10 WASHER



4 PCS

PARTS

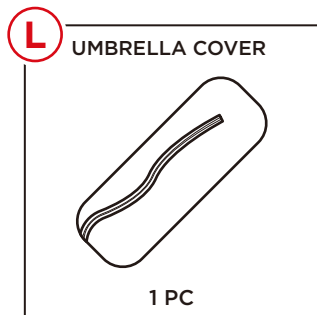
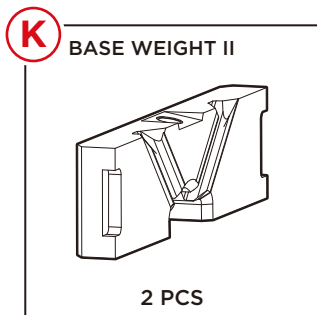
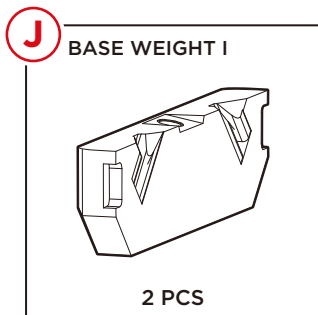
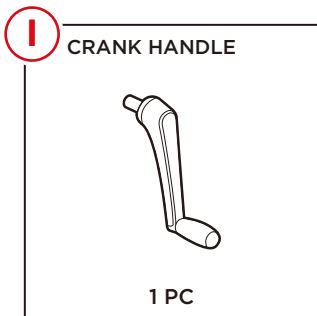
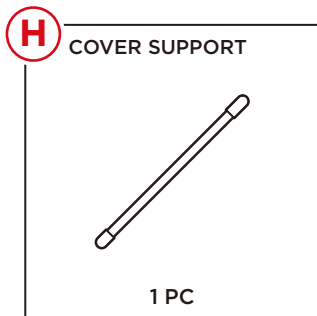
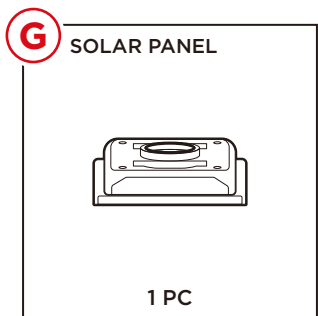
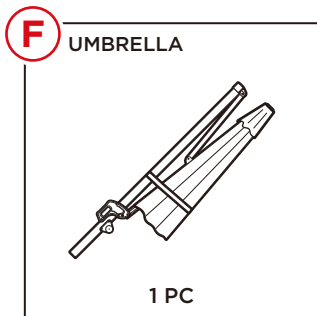
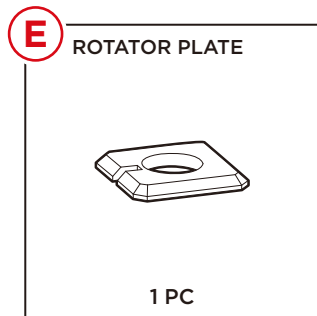
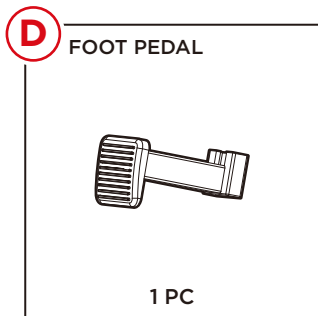
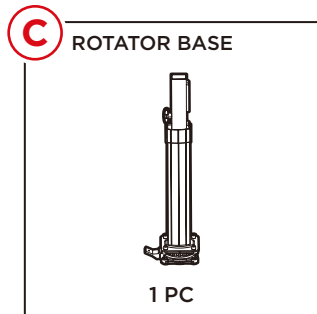
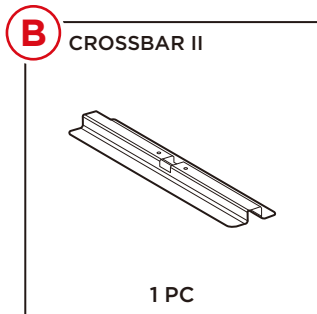
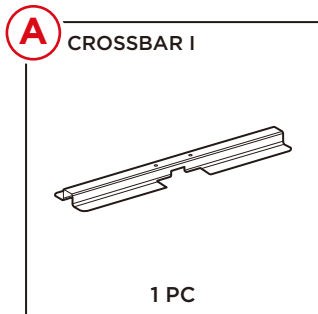

BEFORE FIRST USE

1. Hold the part F umbrella upside down and shake gently to separate the umbrella ribs. If necessary, carefully pull the ribs apart to free them.
2. Insert and secure the part I crank handle into the crank mechanism on the part F umbrella.
3. Slowly turn the crank to open the umbrella. Make sure that the ribs are not stuck together.

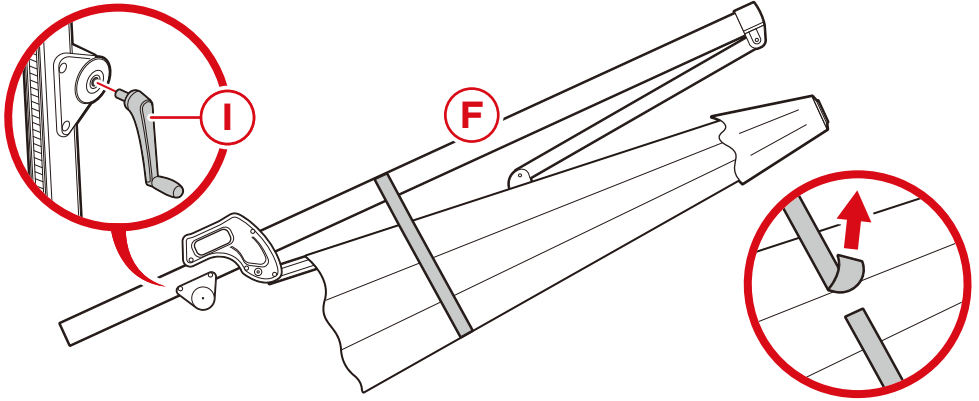

PRODUCT ASSEMBLY

1

Insert the part A crossbar into the part B crossbar and set aside.

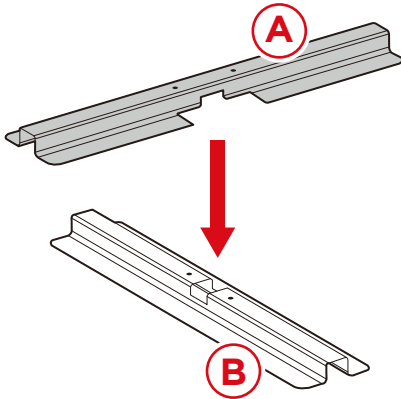

2

Locate the part C rotator base and attach the part D foot pedal with one part 1 bolt.

NOTE: the bolt attaches through the bottom of the foot pedal.

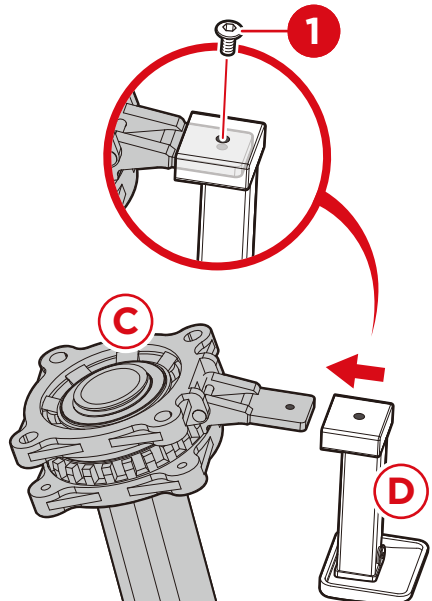

PRODUCT ASSEMBLY

3

Press down on the pedal to rotate the base and expose the lower mounting holes. Overlay the rotator base with the crossbars.

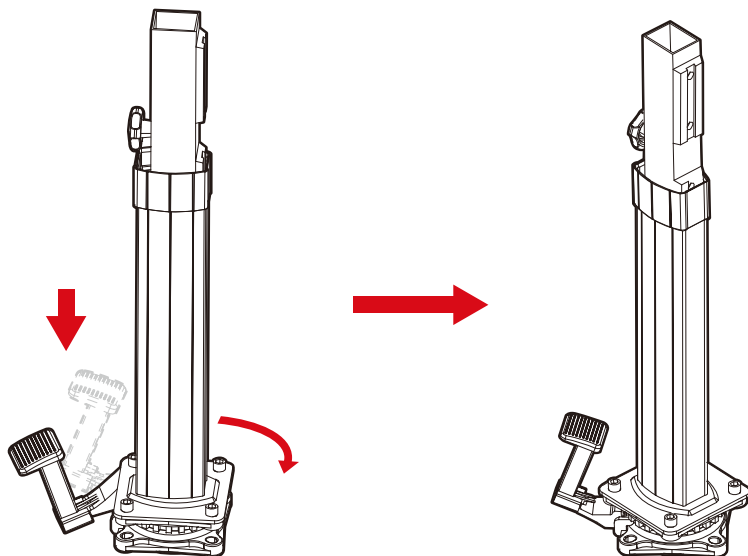

4

Attach the part C rotator base to the part A & B crossbars with four part 2 screws and four part 3 washers.

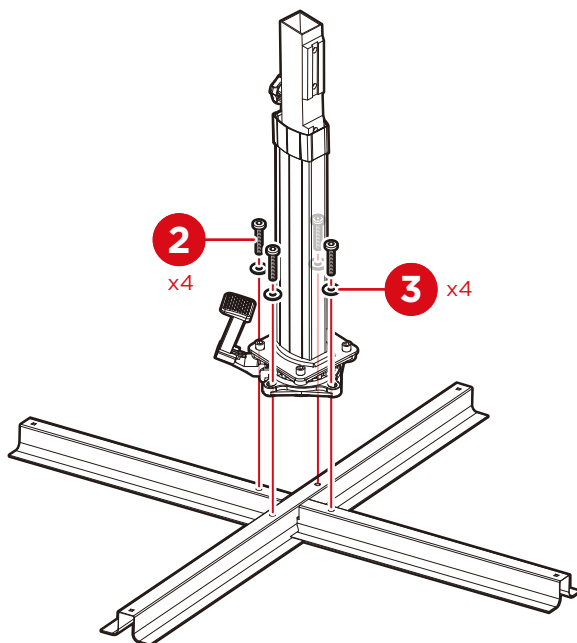

PRODUCT ASSEMBLY

5

Fill the part J & K base weights with your choice of sand or water. (DO NOT MIX sand with water)



CAPACITY PER WEIGHT:

220LBS WATER OR 308LBS SAND

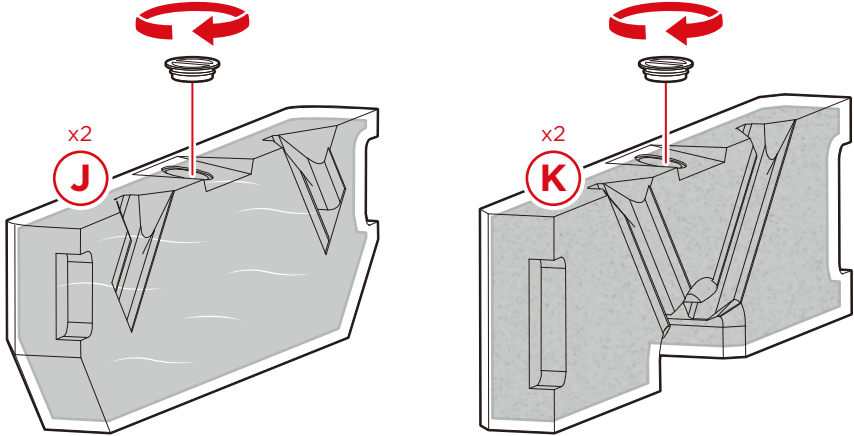

6

Place the base weights over the crossbar assembly, place the part K weights closest to the part C rotator base and the part J weights on the outside.

Slide the part E rotator plate over the part C base.

NOTE: Make sure the pedal can articulate through the plate opening

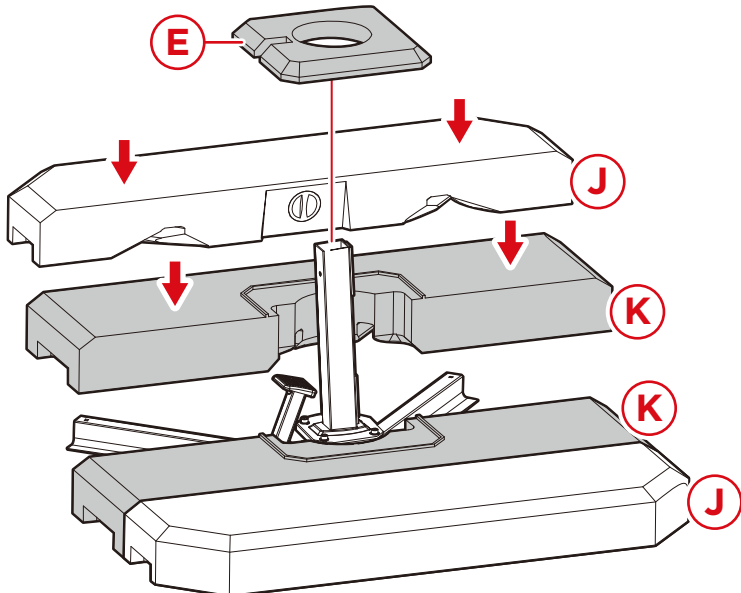

PRODUCT ASSEMBLY

7

Insert the battery connector from the part F umbrella into the part G solar panel. Screw the solar panel onto the top of the pole.

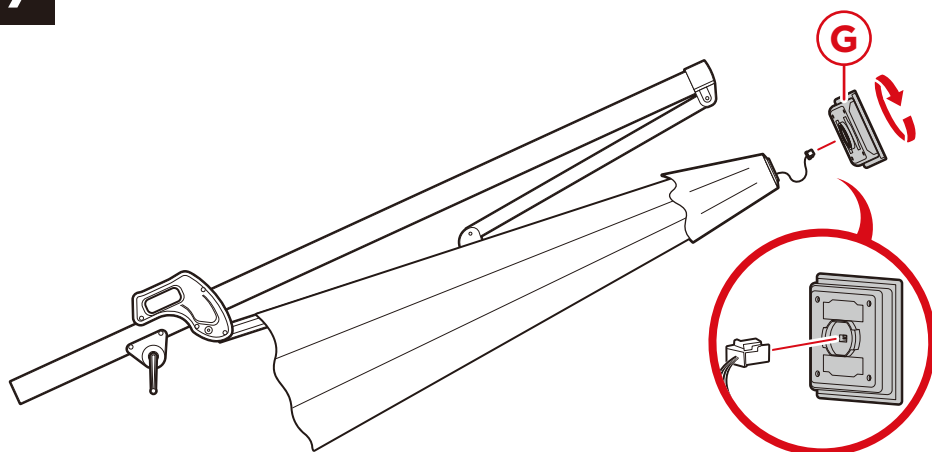

8

Remove the knob on the part C rotator base.

Firmly place the part F umbrella onto the part C rotator base. Reinsert and tighten the knob to secure.

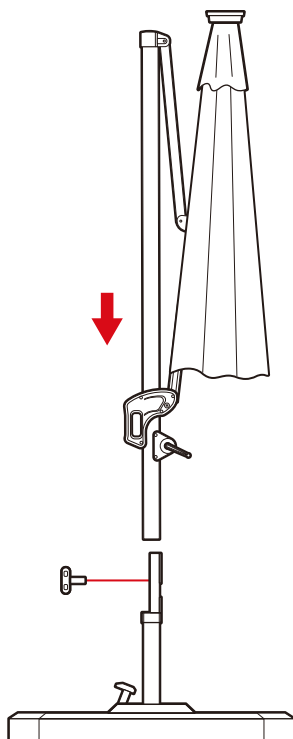

OPENING THE CANOPY

1. Grip and squeeze the handle to engage the release. Move the arm up.
2. Release the handle to lock the canopy in your desired position.
3. Slowly turn the crank to open the canopy.

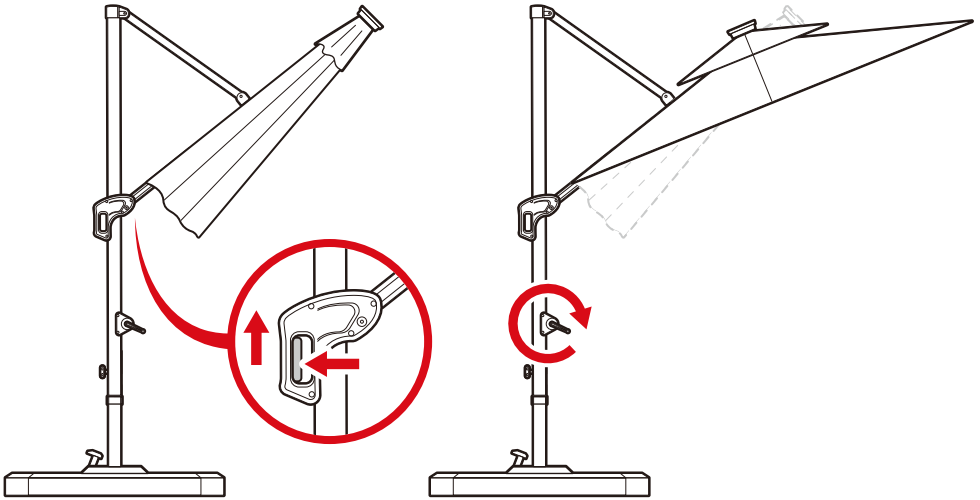

ADJUSTING THE TILT

1. Grip and squeeze the handle and move the arm up/down to adjust the tilt angle of the umbrella.
2. Lock it in your desired position by releasing the handle.
3. Step firmly onto the part D foot pedal to rotate the canopy as needed

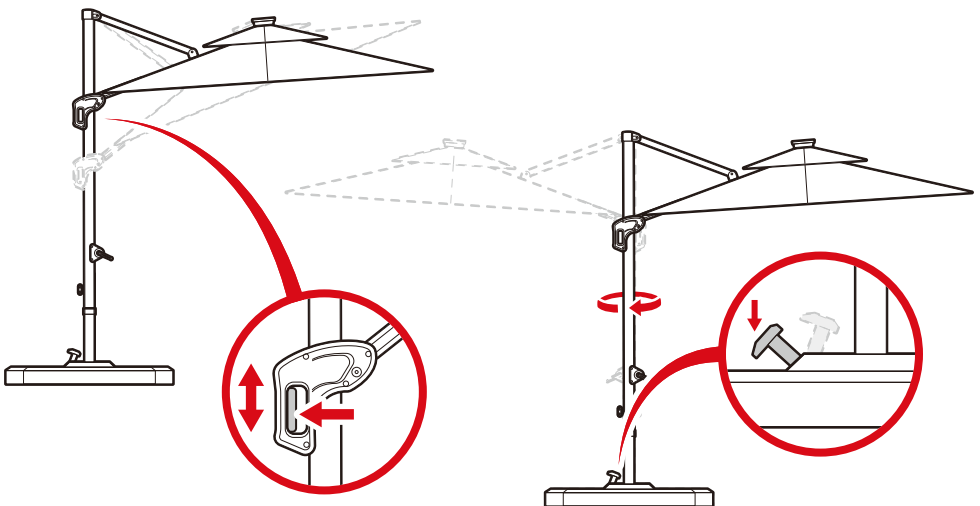

TURNING ON THE LIGHTS

- Press the power switch on the canopy to turn on LED lights.

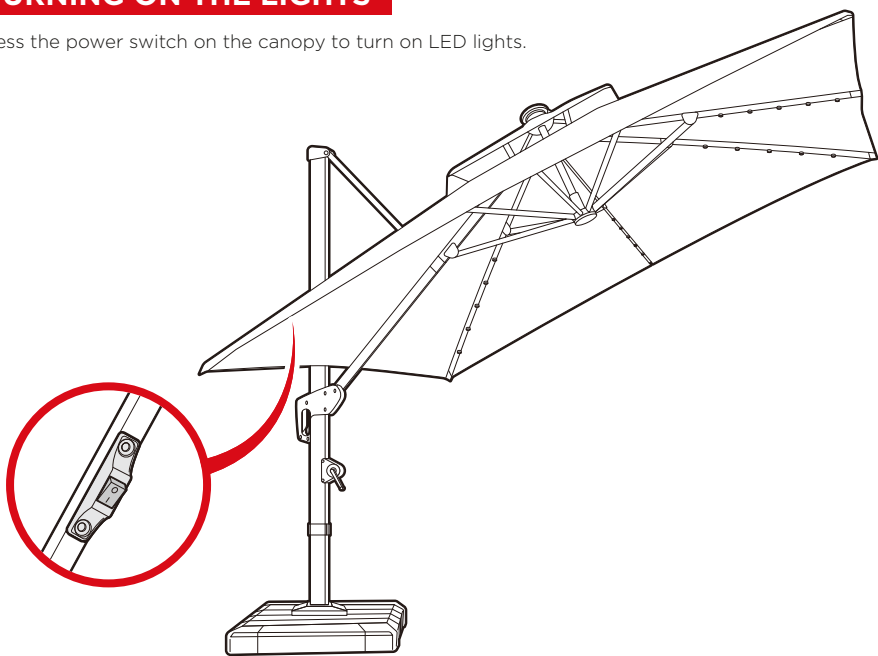

CLOSING THE CANOPY

- Turn the crank counterclockwise to close the canopy.

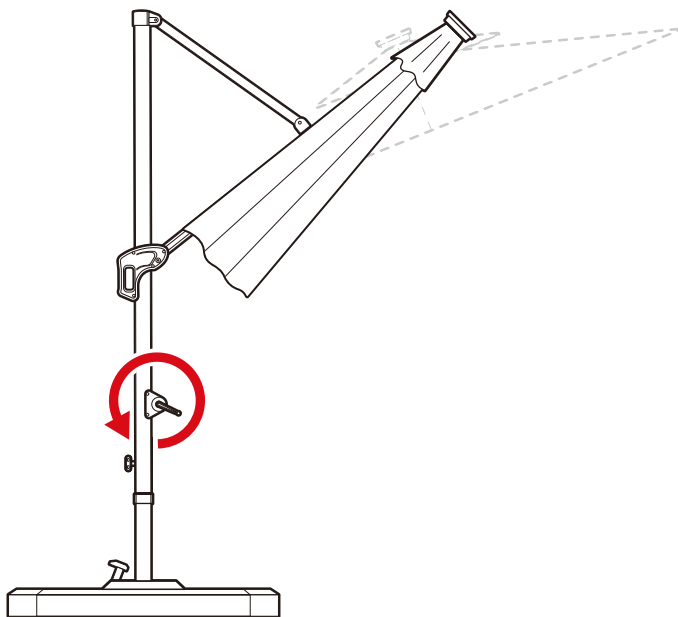

STORAGE

- Close the canopy when umbrella is not in use.
- Grip the handle and move the arm all the way down, then secure the umbrella with the attached touch fastener.
- Slide the part H cover support into the part L umbrella cover, then unzip the cover.
- Slide the cover over the umbrella canopy and secure with the zipper.
- Store in a dry area shielded from the weather.

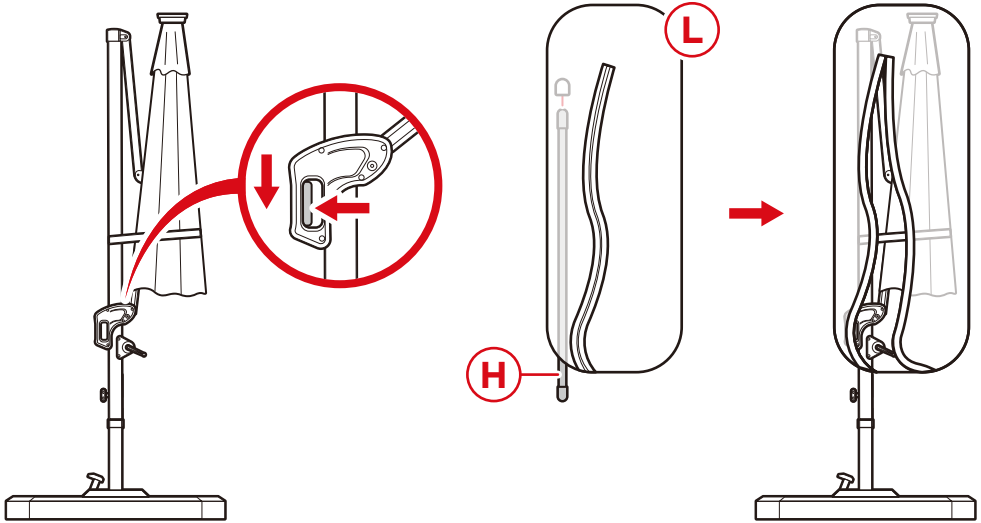

CHARGING THE LIGHTS

- Solar panel requires 6 to 7 hours of direct sunlight to fully charge.
- LED lights last for 6 to 7 hours on a single charge.
- If lights are not working, fully charge the solar panel and try again.

CLEANING

- Wipe clean with mild detergent, warm water, and a soft cloth.
- Do not use abrasive materials or cleaners.



HELP CENTER



Question about your product? We're here to help. Visit us at:

help.bestchoiceproducts.com



Chat Support



Product Inquiry



Orders FAQ



Product Assembly



Returns & Refunds

PRODUCT WARRANTY INFORMATION

All items can be returned for any reason within 60 days of the receipt and will receive a full refund as long as the item is returned in its original product packaging and all accessories from its original shipment are included. All returned items will receive a full refund back to the original payment method. All returned items will not be charged a re-stocking fee.

All returned items require an RA (Return Authorization) number, which can only be provided by a Best Choice Products Customer Service Representative when the return request is submitted. Items received without an RA may not be accepted or may increase your return processing time. Once an item has been received by Best Choice Products, refunds or replacements will be processed within 5 business days.

All returns must be shipped back to the Best Choice Products Return Center at the customer's expense. If the reason for return is a result of an error by Best Choice Products then Best Choice Products will provide a pre-paid shipping label via email. Boxes for return shipping will not be provided by Best Choice Products, and is the customer's responsibility to either use the original shipping boxes or purchase new boxes.

Pictures may be required for some returns to ensure an item is not damaged prior to its return. Items returned are not considered undamaged until they are received by Best Choice Products and verified as such. All damages to items are the customer's responsibility until the item has been received by and acknowledge by Best Choice Products as undamaged.



WARNING

Manufacturer and seller expressly disclaim any and all liability for personal injury, property damage or loss, whether direct, indirect, or incidental, resulting from the incorrect attachment, improper use, inadequate maintenance, unapproved modification, or neglect of this product.