

Bestway®

65047

www.bestwaycorp.com

©2023 Bestway Inflatables & Material Corp.

All rights reserved/Tous droits réservés/Todos los derechos reservados/Alle Rechte vorbehalten/Tutti i diritti riservati

Trademarks used in some countries under license from/

Marques utilisées dans certains pays sous la licence de/

Marcas comerciales utilizadas en algunos países bajo la licencia de/

Die Warenzeichen werden in einigen Ländern verwendet unter Lizenz der/

Marchi utilizzati in alcuni paesi concessi in licenza a

Bestway Inflatables & Material Corp., Shanghai, China

Manufactured, distributed and represented in the European Union by/

Fabriqué, distribués et représentés dans l'Union Européenne par/Fabricado, distribuido y representado en la Unión Europea por/

Hergestellt, vertrieben und in der Europäischen Union vertreten von/Prodotto, distribuito e rappresentato nell'Unione Europea da

Bestway Europe S.p.a., Via Resistenza, 5, 20098 San Giuliano Milanese (Milano), Italy

Distributed in Latin America by/Distribué en Amérique latine par/Distribuido en Latinoamérica por/Distribuído na América Latina por

Bestway Central & South America Ltda, Salar Ascotan 1282, Parque Enea, Pudahuel, Santiago, Chile

Distributed in Australia & New Zealand by **Bestway Australia Pty Ltd, Unit 2/98-104 Carnarvon St Silverwater, NSW 2128, Australia**

Tel: Australia: +61 2 9037 1388; New Zealand: 0800 142 101

Distributed in United Kingdom by **Bestway Corp UK Ltd, 8 Wentworth Road, Heathfield Industrial Estate, Newton Abbot, Devon, TQ12 6TL**

Exported by/Exporté par/Exportado por/Exportiert von/Esportato da

Bestway (Hong Kong) International Ltd./Bestway Enterprise Company Limited

Suite 713, 7/Floor, East Wing, Tsim Sha Tsui Centre, 66 Mody Road, Kowloon, Hong Kong

www.bestwaycorp.com

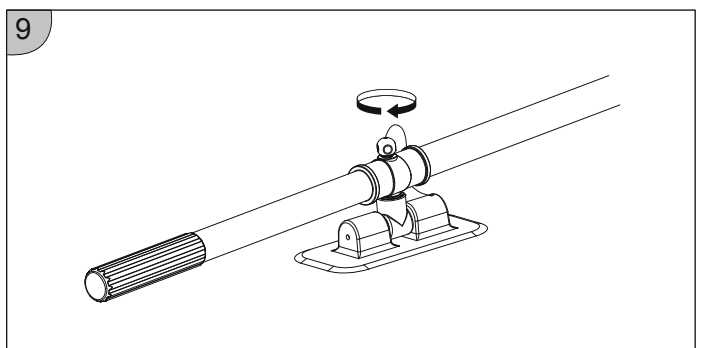
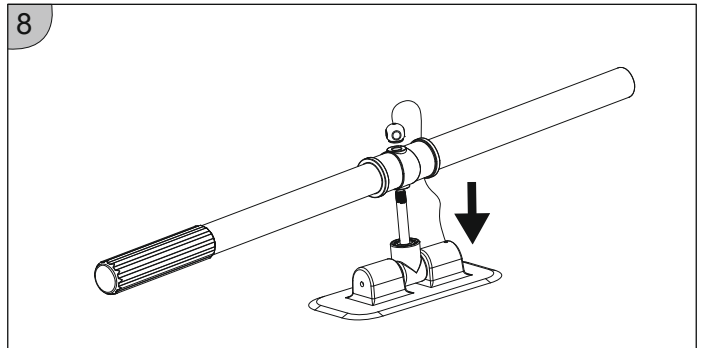
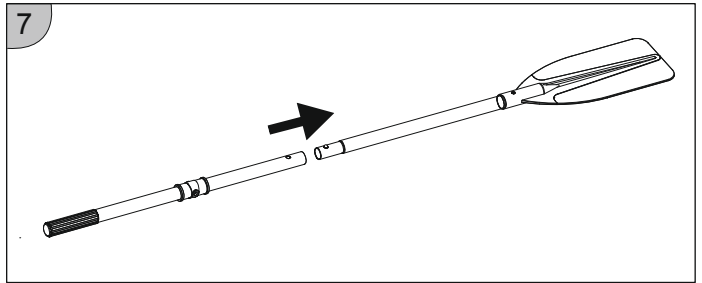
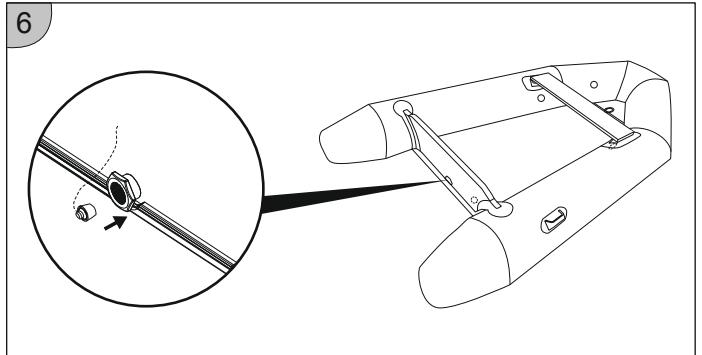
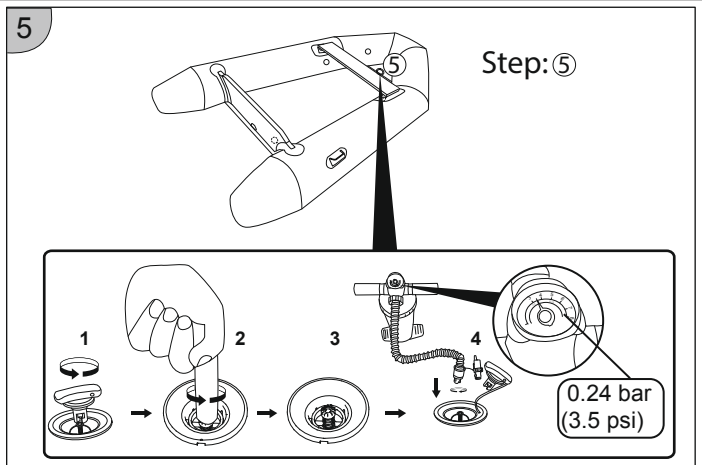
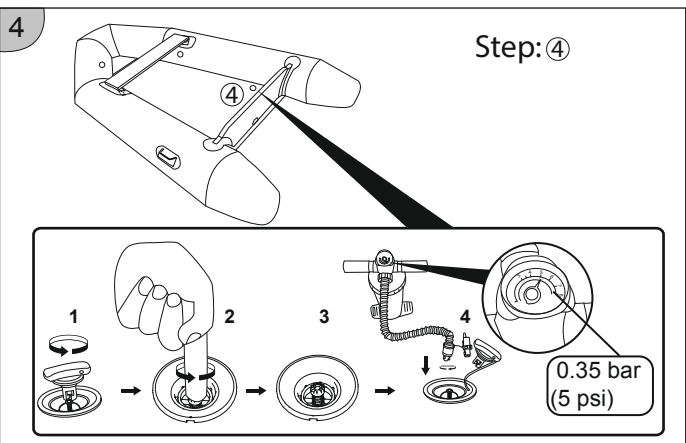
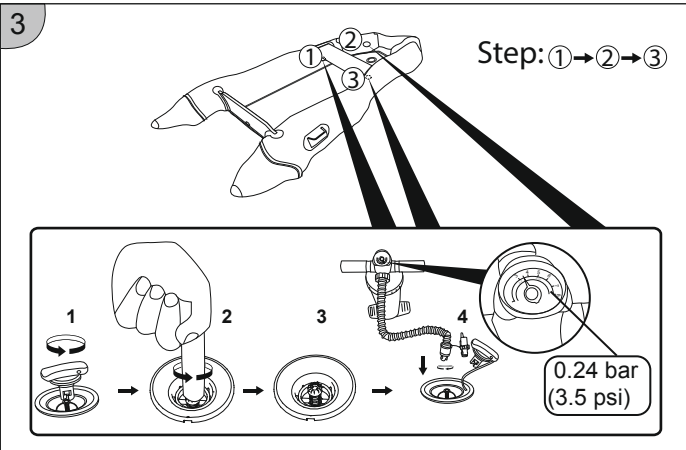
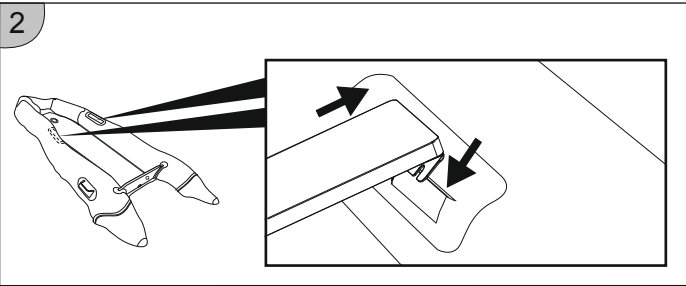
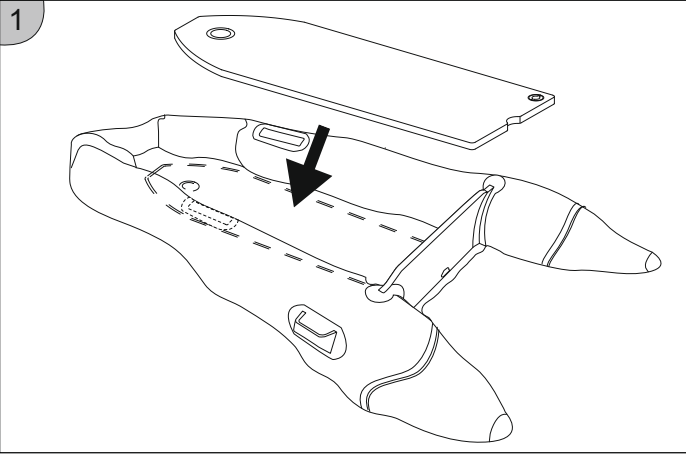

WARNING

IMPORTANT SAFETY INSTRUCTIONS

Follow all the Safety and Operating Instructions. If you don't follow these instructions, it may cause the boat to overturn or explode and result in drowning.

- Do not exceed the maximum recommended number of persons. Regardless of the number of persons on board, the total weight of persons and equipment must never exceed the maximum recommended load. Always use the seats /seating spaces provided.
- When loading the craft, never exceed the maximum recommended load: Always load the craft carefully and distribute loads appropriately to maintain design trim (approximately level). Avoid placing heavy weights high up.
NOTE: The maximum recommended load includes the weight of all persons onboard, all provisions and personal effects, any equipment not included in the light craft mass, cargo (if any) and all consumable liquids (water, fuel, etc.).
- When using the boat, life saving devices such as life jackets and buoys should be pre-inspected and used at all times.
- Before every use, carefully inspect all boat components including air-chambers, grab ropes, oars, and air valves, to ensure everything is in good condition and tightly secured. If you find any damage, please repair before commencing use.
- Buckets, water scoops and air pumps should always be available in case of air leakage or if the boat takes on water.
- When the boat is in motion, all passengers must remain seated at all times to avoid going overboard. Keep the boat balanced. Uneven distribution of persons or load in the boat may cause the boat to overturn and result in drowning.
- Use the boat near the shore and beware of natural factors such as wind, tide waters and tidal waves. **BE AWARE OF OFFSHORE WINDS AND CURRENTS.**
- If one chamber is punctured when the boat is in the water, it may be necessary to fully inflate the other air chamber to prevent the boat from sinking.
- Be careful when landing on the shore. Sharp and rough objects such as rocks, cement, shells, glass, etc. may puncture the boat. To avoid damage, do not drag the boat on rough surfaces.
- When choosing an outboard motor, refer to the technical specifications section of this manual to determine acceptable horsepower ratings.
- For electrical motors equipped with batteries, note that battery acid can be caustic, which can cause damage to both skin and boat materials.
- For motors which use fuels such as gas, oil or petrol, since fuel is a flammable substance, it should be kept away from open flames. Further, clean the boat material immediately if fuel spatters onto the boat surface. Be aware of the potential harmful effects of liquids such as battery acid, oil or petrol. The liquids may damage your boat.
- Inflate according to the numbered air chamber and rated pressure of the boat, or it will cause over-inflation and potential explosion. Exceeding the data given on the capacity plate may cause the craft to be damaged, overturn and lead to drowning.
- If you use the tow rings to tow the boat, go slowly to avoid over-towing as damage may occur.
- Know how to operate a boat. Check in your local area for information and/or training as needed. Inform yourself about local regulations and dangers related to boating and/or other water activities.

SAVE THESE INSTRUCTIONS

Part list

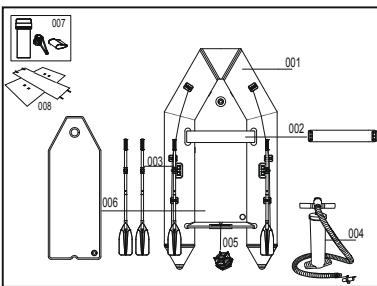

Part No.	Description	QTY
001	Boat	1
002	Bench seat	1
003	Oar	1 pair
004	Air pump	1
005	Drain valve	1
006	Airdeck floor	1
007	Repair kit	1
008	Bag	1

WARNING: To avoid damage to the boat and injury to passengers, please don't exceed the data given on the builder's plate.

Item	Size	Recommended working pressure	Airdeck floor pressure	Maximum load capacity	Maximum motor power
65047	9'2" x 60" x 16.5" 2.80m x 1.52m x 42cm	3.5 psi 0.24 bar	5 psi 0.35 bar	480 kg (1058.2 lbs.) 3 adults + 1 child	7.5 kW (10 hp)

Note:

- The airdeck floor must be assembled before inflating the hull.
- Extended exposure to sun can shorten the lifespan of your boat. We suggest not leaving boats in direct sunlight for more than 1 hour after use.
- NOTE:** Pressure gauge is for inflation purpose only, and the value of the pressure gauge is just for reference, should not be used as a precision instrument.

- Only use Bestway® approved inflation pumps.
- Never use motor-driven high-pressure air pumps as this may result in over-inflation.
- Under and over-inflation will result in safety hazards.
- Always check the inflation pressure before using the boat.
- Never stand on or rest objects on the boat during inflation.
- Never open the cap of air valve while the boat is in use.
- Be sure the valve is tightly closed before using the boat.

Note: When the oars are not in use, lock the oars into the Oar Clamps to avoid damage.

Outboard Motor Installation

With the boat fully inflated and in the water, attach your outboard motor onto Engine Mount at the center of the Transom.

Note:

- Ensure the motor is always fixed on the Transom.
- Read the instruction of outboard motor for correct installation and operation.
- Overpowering a boat can result in serious injury, death or boat damage. The maximum motor power to be used see marking on the product.

Maintenance

- Inflate according to the PSI marked besides the valve;
- To avoid excessive exposure to sun & rain, cover the boat when not in use.
- Clean it with mild soap water and soft cloth in case it is not going to be used for a long time. Dry it before putting them away. Store it at a dry and shady place and keep it out of reach of Children.
- Use the spanner to tighten the air valve if it is leaking .

Deflation

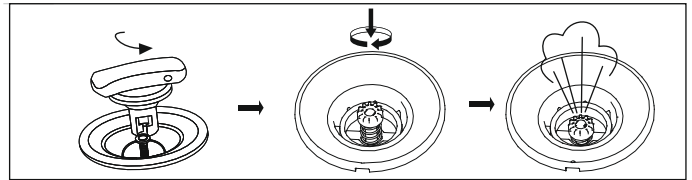

Storage

- Remove the Oars from the oarlocks.
Note: Keep all accessories for future use.
- Carefully clean the boat using a mild soap with clean water.
Note: Do not use acetone, acid, and/or alkaline solutions.
- Use a cloth to gently dry all surfaces.
Note: Do not dry the product in direct sunlight. Also, never dry with equipment such as electric blowers. Doing so will cause damage and shorten the boat's life span.
- To deflate, open the Air Valves pushing the control stem in and rotating until the valves stay open. Deflate all the hull chambers at the same time so the air-pressure drops together. This will prevent damage from occurring to the boat's inner structures.
- Next deflate the Keel.
- Disassemble the seat and floor.
- Fold the boat from front to back to remove additional air. You can also use a pump to drain any remaining air.

REPAIR INSTRUCTIONS:

- Fully clean the area to be repaired.
- Cut the correct size from the repair patch material.
- Apply only the amount of glue needed to cover the repair site.
- Press the repair patch firmly to repair site for 30 seconds.
- Wait for 1 hour before inflation.

The glue is not included in the repair kit due to shipping constraints. You can find silicone-based glue at most retail outlets. Carefully read the warning labels and closely follow instructions on the back of glue before attempting the following repair steps.

Registration (For US/Canada customers only)

If you need to register your boat, please have the boat Hull Identification Number and model name ready and then visit bestwaycorp.com/support to obtain your Certificate of Origin, or you can send e-mail to service@bestwaycorp.us for the Certificate of Origin.

PLEASE KEEP THIS MANUAL IN A SECURE PLACE, AND HAND IT OVER TO THE NEW OWNER WHEN YOU SELL THE CRAFT.

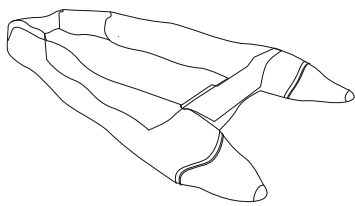

001

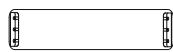

002

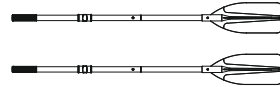

003

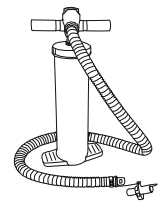

004

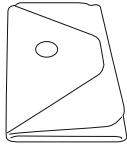

006



007

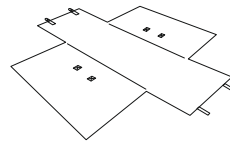

008

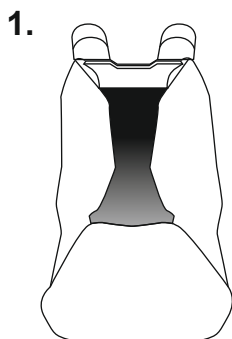

1.

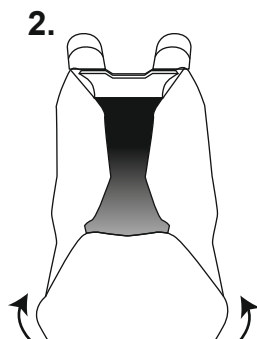

2.

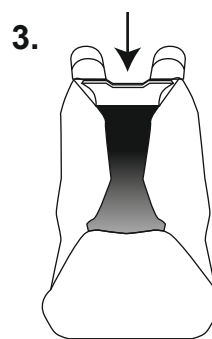

3.

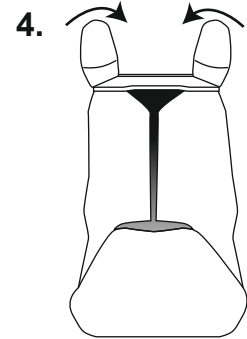

4.

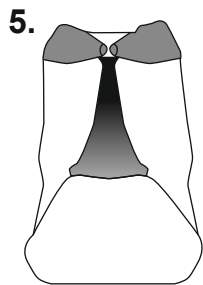

5.

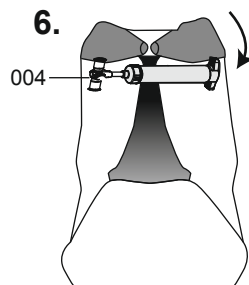

6.

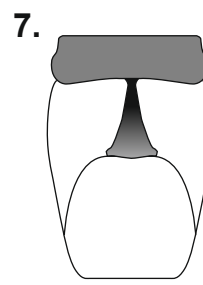

7.

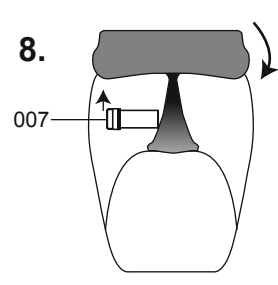

8.

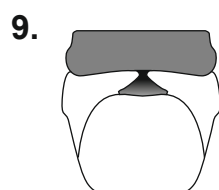

9.

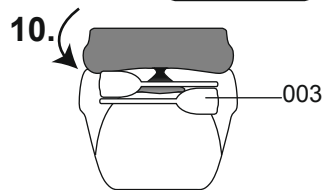

10.

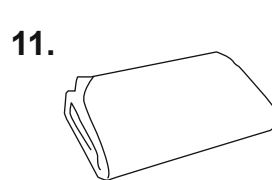

11.

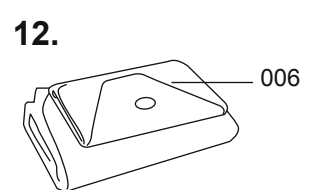

12.

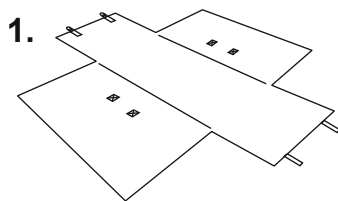

1.

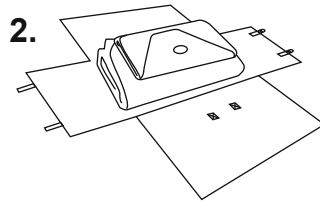

2.

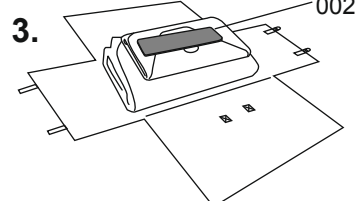

3.

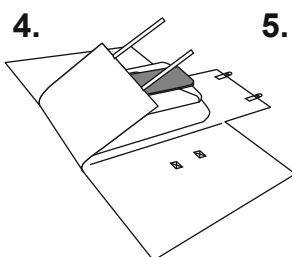

4.

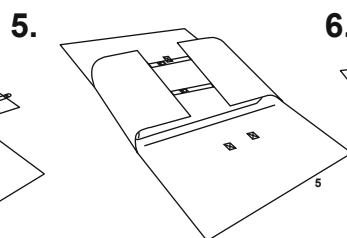

5.

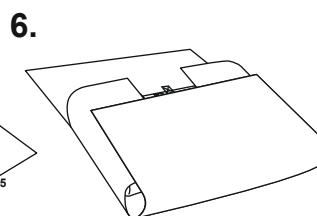

6.

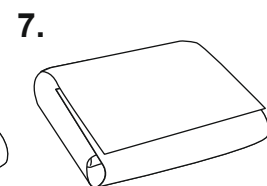

7.