

# Owner's Manual & Safety Instructions

## ***BILT HARD***

### **173CC OHV VERTICAL SHAFT GAS ENGINE TL-EG-V173**

#### **⚠ DANGER**

Using an engine indoors **CAN KILL YOU IN MINUTES.**

Engine exhaust contains carbon monoxide. This is a poison you cannot see or smell.



**NEVER** use inside a home or garage, **EVEN IF** doors and windows are open.

Only use **OUTSIDE** and far away from windows, doors, and vents.

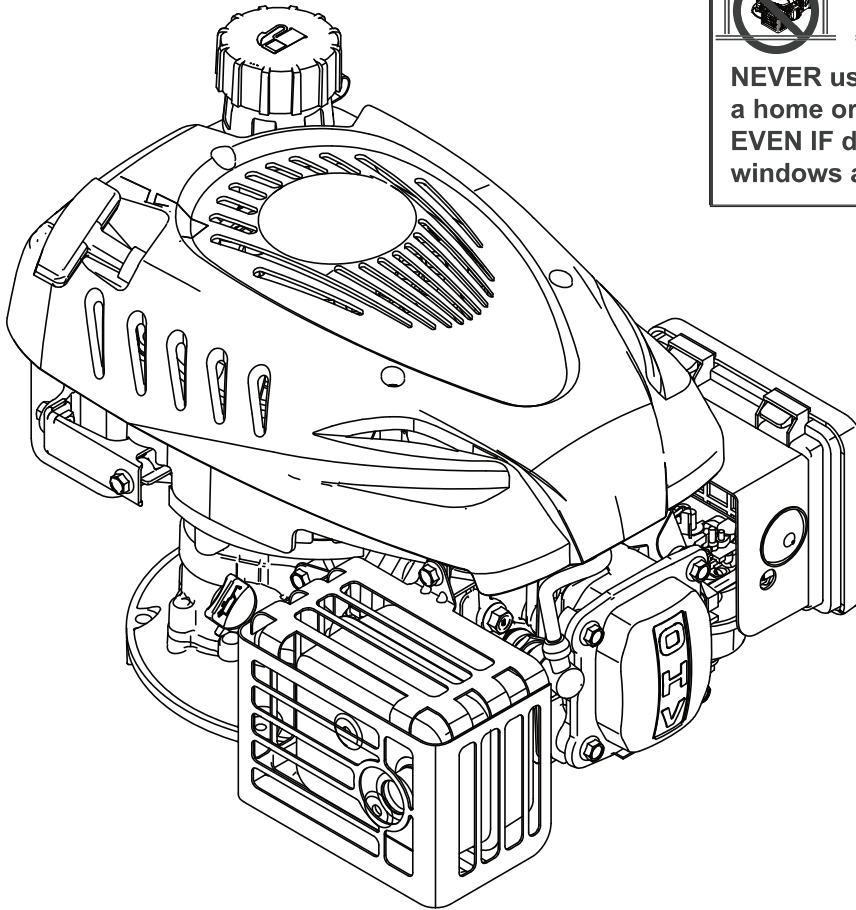

**SAVE THIS MANUAL** Keep this manual for the safety warnings and precautions, assembly, operating, inspection, maintenance and cleaning procedures. Write the product's serial number in the back of the manual near the assembly diagram (or month and year of purchase if product does not carry a number). Keep this manual and receipt in a safe and dry place for future reference.

Thank you for ordering our products. Should you have any queries, please feel free to contact us at (888)680-2849 or email to [inquiry@bilthardusa.com](mailto:inquiry@bilthardusa.com). We always find ways to improve!

## Table of Contents





Specifications .....	2	Troubleshooting .....	15
Safety Warnings .....	3	Warranty .....	17
Set Up .....	6	Part List .....	20
Operation .....	9	Diagrams .....	22
Maintenance .....	12		

### Specifications



Displacement		<b>173cc</b>
Engine Type		Vertical Engine Single Cylinder 4-stroke EPAIII & CARB Compliant
Cooling System		Forced Air Cooled
Max. RPM		3800 RPM
Max. Torque		7.68 lb-ft @2500RPM
Fuel	Type	87+octane stabilizer treated unleaded
	Capacity	0.25Gallon/0.95L
Engine Oil	Type SAE	SAE10W-30
	Capacity	0.54Quart/0.5L
Run Time @ 50% Load		40 minutes
Bore x Stroke		70x45mm
Compression Ratio		8.3:1
Rotation view from PTO		Counterclockwise
Spark Plug	Type	Torch®DK7RTC
	Gap	0.027" - 0.031"
Valve Clearance	Intake	0.004" - 0.006"
	Exhaust	0.006" - 0.008"
Speed	Idle	1900±100 RPM
Shaft	Dimension	Φ7/8"x3.16"(L)
	Height	NA
	Keyway	3/16"
	End Tapped	3/8"-24UNF
Mounting Pattern(LxW)		Dia.8"(203mm); Φ3/8" - 24 UNF tapped hole x 1;Φ 0.34"/8.7mm through-hole x 2;



# BILT HARD

# SAFETY WARNINGS

WARNING SYMBOLS AND DEFINITIONS	
	This is the safety alert symbol. It is used to alert you to potential personal injury hazards. Obey all safety messages that follow this symbol to avoid possible injury or death.
	Indicates a hazardous situation which, if not avoided, will result in death or serious injury.
	Indicates a hazardous situation which, if not avoided, could result in death or serious injury.
	Indicates a hazardous situation which, if not avoided, could result in minor or moderate injury.
	Addresses practices not related to personal injury.

## Symbol Definitions

Symbol	Property or Statement
<b>RPM</b>	Revolutions Per Minute
<b>HP</b>	Horsepower
	WARNING marking concerning Risk of Eye Injury. Wear ANSI-approved safety goggles with side shields.
	Read the manual before set-up and/or use.
	WARNING marking concerning Risk of Hearing Loss. Wear hearing protection.

Symbol	Property or Statement
	WARNING marking concerning Risk of Respiratory Injury. Operate engine OUTSIDE and far away from windows, doors, and vents.
	WARNING marking concerning Risk of Fire while handling fuel. Do not smoke while handling fuel.
	WARNING marking concerning Risk of Fire. Do not refuel while operating. Keep flammable objects away from engine.

## Safety Warnings



**WARNING! Read all instructions.**

**Failure to follow all instructions listed below may result in fire, serious injury and/or DEATH.**

The warnings and precautions discussed in this manual cannot cover all possible conditions and situations that may occur. It must be understood by the operator that common sense and caution are factors which cannot be built into this product, but must be supplied by the operator.

**SAVE THESE INSTRUCTIONS**

## SAFETY WARNINGS(cont.)

### Set Up Precautions.

1. This unit is to be installed so that access is restricted to only qualified service person who have been instructed of the reasons for the restrictions applied to the location and about any precautions that must be taken. Access shall be through the use of a special tool, or lock and key, or other means of security and shall be controlled by the authority responsible for the location.
2. Gasoline fuel and fumes are flammable, and potentially explosive. Use proper fuel storage and handling procedures. DO NOT store fuel or other flammable materials nearby.
3. Have multiple ABC class fire extinguishers nearby.
4. Operation of this equipment may create sparks that can start fires around dry vegetation. A spark arrestor may be required. The operator should contact local fire agencies for laws or regulations relating to fire prevention requirements.
5. Set up and use only on a flat, level, well ventilated surface.
6. Wear ANSI-approved safety goggles, heavy-duty work gloves, and dusk mask/respirator during set up.
7. Use only lubricants and fuel recommended in the Specifications chart of this manual.

### Operating Precautions

1.  **CARBON MONOXIDE HAZARD**  
**Using an engine indoors**  
**CAN KILL YOU IN MINUTES.**  
Engine exhaust contains carbon monoxide. This is a poison you cannot see or smell.

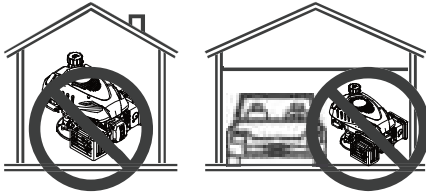

NEVER use inside a home or garage, EVEN IF doors and windows are open.

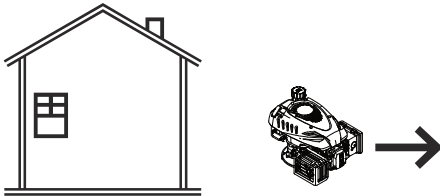

Only use OUTSIDE and far away from windows, doors, and vents.

2. Keep children away from the equipment, especially while it is operating.
3. Keep all spectators at least six feet from the Engine during operation.
4. Fire Hazard! Do not fill gas tank while engine is running. Do not operate if gasoline has been spilled. Clean spilled gasoline before starting engine. Do not operate near pilot light or open flame.
5. Do not touch engine during use. Let engine cool down after use.
6. Never store fuel or other flammable materials near the engine.
7. Only use a suitable means of transport and lifting devices with sufficient weight bearing capacity when transporting the Engine.
8. Secure the Engine on transport vehicles to prevent the tool from rolling, slipping, and tilting.
9. Industrial applications must follow OSHA requirements.
10. Do not leave the equipment unattended when it is running. Turn off the equipment (and remove safety keys, if available) before leaving the work area.
11. Engine can produce high noise levels. Prolonged exposure to noise levels above 85 dBA is hazardous to hearing. Always wear ear protection when operating or working around the gas engine while it is operating.
12. Wear ANSI-approved safety glasses, hearing protection, and NIOSH-approved dust mask/respirator under a full face shield along with steel-toed work boots during use.
13. People with pacemakers should consult their physician(s) before use. Electromagnetic fields in close proximity to a heart pacemaker could cause pacemaker interference or pacemaker failure. Caution is necessary when near the engine's magneto or recoil starter.
14. Use only accessories that are recommended by Bilt Hard for your model. Accessories that may be suitable for one piece of equipment may become hazardous when used on another piece of equipment.
15. Do not operate in explosive atmospheres, such as in the presence of flammable liquids, gases, or dust. Gasoline-powered engines may ignite the dust or fumes.
16. Stay alert, watch what you are doing and use common sense when operating this piece of equipment. Do not use this piece of equipment while tired or under the influence of drugs, alcohol or medication.
17. Do not overreach. Keep proper footing and balance at all times. This enables better control of the equipment in unexpected situations.
18. Use this equipment with both hands only. Using equipment with only one hand can easily result in loss of control.
19. Dress properly. Do not wear loose clothing or jewelry. Keep hair, clothing and gloves away from moving parts. Loose clothes, jewelry or long hair can be caught in moving parts.

## SAFETY WARNINGS(cont.)

### Operation Precautions

20. Parts, especially exhaust system components, get very hot during use. Stay clear of hot parts.
21. Do not cover the engine or equipment during operation.
22. Keep the equipment, engine, and surrounding area clean at all times.
23. Do not smoke, or allow sparks, flames, or other sources of ignition around the equipment, especially when refuelling.
24. Use the equipment, accessories, etc., in accordance with these instructions and in the manner intended for the particular type of equipment, taking into account the working conditions and the work to be performed. Use of the equipment for operations different from those intended could result in a hazardous situation.
25. Do not operate the equipment with known leaks in the engine's fuel system.
26. **WARNING:** This product contains or, when used, produces a chemical known to the State of California to cause cancer and birth defects or other reproductive harm. (California Health & Safety Code § 25249.5, *et seq.*)
27. When spills of fuel or oil occur, they must be cleaned up immediately. Dispose of fluids and cleaning materials as per any local, state, or federal codes and regulations. Store oil rags in a bottom-ventilated, covered, metal container.
28. Keep hands and feet away from moving parts. Do not reach over or across equipment while operating.
29. Before use, check for misalignment or binding of moving parts, breakage of parts, and any other condition that may affect the equipment's operation. **If damaged, have the equipment serviced before using.** Many accidents are caused by poorly maintained equipment.
30. Use the correct equipment for the application. Do not modify the equipment and do not use the equipment for a purpose for which it is not intended.

### Service Precautions

1. Before service, maintenance, or cleaning:
  - a. Turn the engine switch to "OFF" position.
  - b. Allow the engine to completely cool.
  - c. Remove the spark plug cap from the spark plug.
2. Keep all safety guards in place and in proper working order. Safety guards include muffler, air cleaner, mechanical guards, and heat shields, among other guards.
3. Do not alter or adjust any part of the equipment or its engine that is sealed by the manufacturer or distributor. Only a qualified service technician can adjust parts that may increase or decrease governed engine speed.
4. Wear ANSI approved safety goggles, heavy-duty work gloves, and dust mask/respirator during service.
5. Maintain labels and nameplates on the equipment, which carry important information. If unreadable or missing, contact Bilt Hard for replacement.
6. Have the equipment serviced by a qualified repair person using only identical replacement parts. This will ensure that the safety of the equipment is maintained. Do not attempt any service or maintenance procedures not explained in this manual or any procedures that you are uncertain about your ability to perform safely or correctly.
7. Store equipment out of the reach of children.
8. Follow scheduled engine and equipment maintenance.

#### Refueling:

1. **DO NOT** refill the fuel tank while the engine is running or hot.
2. **DO NOT** smoke, or allow sparks, flames, or other sources of ignition around the equipment, especially when refueling.
3. **DO NOT** fill fuel tank to the top. Spare room for the fuel to expand as needed. To prevent fuel leakage and fire hazard, **DO NOT** fill above the bottom of the fuel strainer.

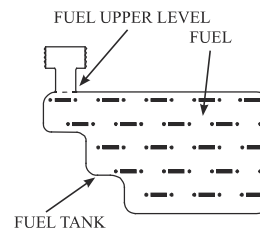

**Max Fuel  
DO NOT OVERFILL!**

4. Refuel in a well-ventilated area only.
5. Wipe up any spilled fuel and allow excess to evaporate before starting engine. **To prevent FIRE, DO NOT start the engine while the smell of fuel hangs in the air.**



**SAVE THESE INSTRUCTIONS.**

## SET UP(cont.)



Read the **ENTIRE IMPORTANT SAFETY INFORMATION** section at the beginning of this manual including all text under subheadings therein before set up or use of this product.

### **WARNING**

**TO PREVENT SERIOUS INJURY:**

Operate only with proper spark arrestor installed.



Operation of this equipment may create sparks that can start fires around dry vegetation. A spark arrestor may be required.

The operator should contact local fire agencies for laws or regulations relating to fire prevention requirements.

**WARNING! DO NOT INSTALL THIS ENGINE ON A VEHICLE.**

**NOT FOR HIGHWAY USE. FOLLOW ALL APPLICABLE LAWS FOR INSTALLATION AND USE.**

**WARNING! INSTALL THIS ENGINE ACCORDING TO EQUIPMENT INSTRUCTIONS BEFORE USE.**

## Components and Controls

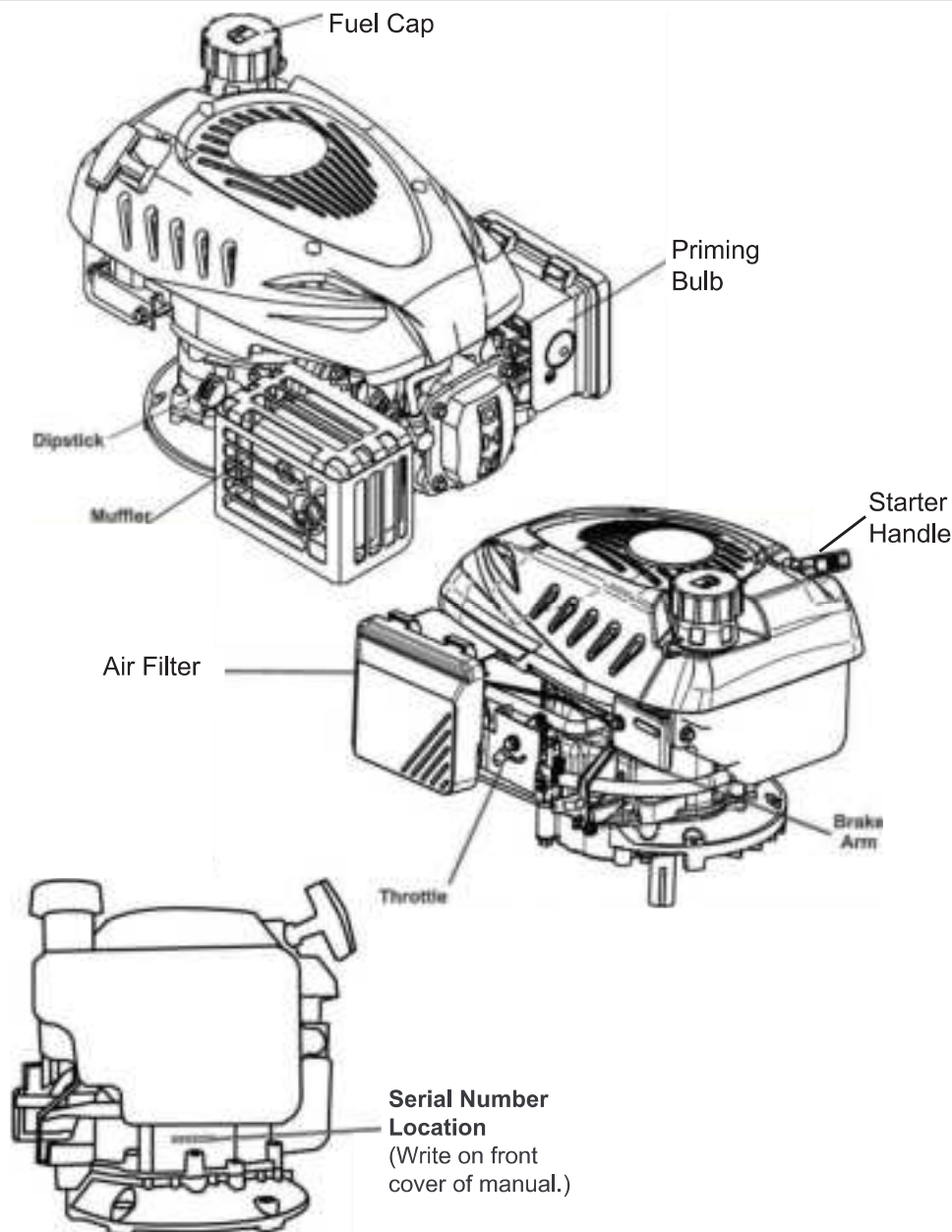

# High Altitude Operation Above 3000 Feet

**⚠️ WARNING! TO PREVENT SERIOUS INJURY FROM FIRE:**

Follow instructions in a well-ventilated area away from ignition sources.

If the engine is hot from use, shut the engine off and wait for it to cool before proceeding. Do not smoke.

At high altitudes, the engine’s carburetor, governor (if so equipped), and any other parts that control the fuel-air ratio will need to be adjusted by a qualified mechanic to allow efficient high-altitude use and to prevent damage to the engine and any other devices used with this product. The fuel system on this engine may be influenced by operation at higher altitudes. Proper operation can be ensured by installing an altitude kit(**not included**) at altitudes higher than 3000 ft. above sea level. At elevations above 8000 ft, the engine may experience decreased performance, even with the proper main jet. Operating this engine without the proper altitude kit installed may increase the engine’s emissions and decrease fuel economy and performance. The kit should be installed by a qualified mechanic.

1. Turn off the engine.
2. Close the fuel valve(if equipped).
3. Place a bowl under the fuel cup to catch any spilled fuel.

**CAUTION!** Carburetor bowl may have gas in it which will leak upon removing the bolt.

4. Unthread the bolt holding the fuel cup.
5. Remove the bolt, Bolt Seal, fuel cup, Fuel Cup Seal and Main Jet from the body of the carburetor assembly.  
A carburetor screwdriver (not included) is needed to remove and install the Main Jet.

**Note:** The mixing tube is held in place by the Main Jet and might fall out when it is removed. If it falls out, replace it in the same orientation before replacing the Main Jet.

**NOTICE** Warranty void if necessary adjustments are not made for high altitude use.

6. Replace the Main Jet with the replacement Main Jet needed for your altitude range (part 1a or 2a).

**Note:** The Fuel Cup Seal and Bolt Seal may be damaged during removal and should be replaced with the new ones from the kit.

7. Replace the Fuel Cup Seal (4a), fuel cup, Bolt Seal (3a), and bolt. Tighten in place.

**NOTICE:** Do not cross thread bolt when tightening. Finger tighten first and then use a wrench to make sure the bolt is properly threaded.

8. Wipe up any spilled fuel and allow excess to evaporate before starting engine. To prevent FIRE, do not start the engine while the smell of fuel hangs in the air.

## High Altitude Kit Parts List - A

Part	Description	Qty
1a	Main Jet 3000-6000 ft.	1
2a	Main Jet 6000-8000 ft.	1
3a	Bolt Seal	1
4a	Fuel Cup Seal	1

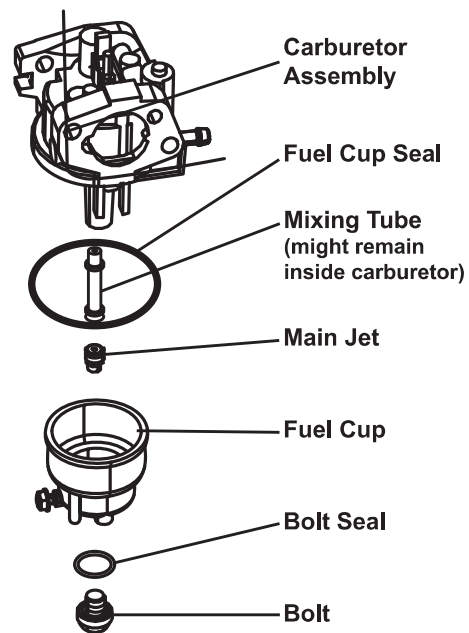

# INSTALLATION

1. **IMPORTANT:** If you have any doubts about your ability to perform the following procedures, have a qualified service technician perform the installation.
2. Install this engine on a lawn mower only. Do not use to power a vehicle.
3. Mounting hole locations:

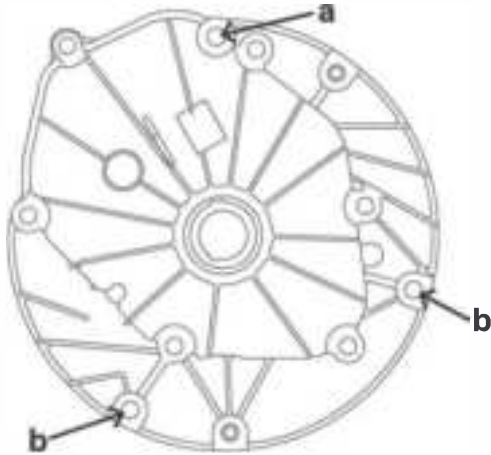

- a. one 3/8 in. x 24 threaded; 1 in. deep
- b. two Ø0.34 in. / 8.7mm unthreaded (use 5/16 in. / 8mm diameter hardware)

4. Set the Engine upright on the mower, and align at least three engine mounting holes with mower mounting holes.

**NOTE:** Depending on the mower, it may be necessary to drill mounting holes or make a mounting plate to align with the engine mounting holes. Only a qualified technician should attempt these solutions.

5. Use hardened, stainless steel Bolts, Lock Washers, and Washers (not included) of appropriate length and diameter to secure the Engine to the mower. **Make sure the hardware will not contact moving parts during operation.**

6. Insert the mower's brake cable sheath through the hole in the Brake bracket. Secure the mower brake cable to the brake arm. Adjust the brake cable sheath to remove all slack and secure it in place using the adjusting nuts on the cable sheath, as shown in the illustration below.

**THE ENGINE BRAKE IS FOR EMERGENCY SHUTOFF; DO NOT REPLACE THE BRAKE SPRING WITH A WEAKER SPRING.**

**If operating the engine brake is too difficult, a qualified technician must install a different brake handle on the mower.**

**Note:** The brake cable on some mowers may need to be adjusted in a different manner. Install according to mower manufacturer's instructions.

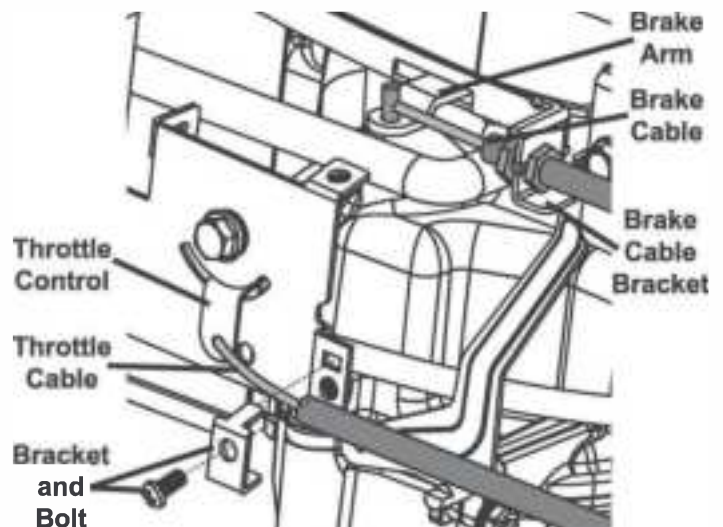

7. Attach the end of the mower's Throttle Cable to the Throttle Control. Use the Bracket and Bolt to secure its sheath in place as shown above.
8. Refer to the mower's service manual for instructions on how to properly attach a belt drive pulley, chain drive gear, etc. onto the output shaft of the Engine.

# OPERATION



Read the **ENTIRE IMPORTANT SAFETY INFORMATION** section at the beginning of this manual including **all text** under subheadings therein before set up or use of this product.

## Pre-Start Checks

Inspect engine and equipment looking for damaged, loose, and missing parts before set up and starting. If any problems are found, do not use equipment until fixed properly.

### Checking and Filling Engine Oil

**NOTICE:** Your Warranty is **VOID** if the engine's crankcase is not properly filled with oil before each use. Before each use, check the oil level. Engine **will not start with low or no engine oil.**

1. Make sure the engine is stopped and is level.
2. Close the Fuel Valve.
3. Clean the top of the Dipstick and the area around it. Remove the Dipstick by turning it counterclockwise, and wipe it off with a clean, lint free rag.

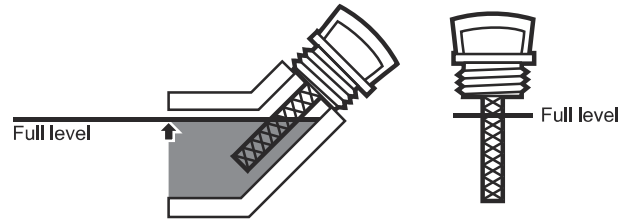

4. Reinsert the Dipstick without threading it in and remove it to check the oil level. The oil level should be up to the full level as shown above.
5. If the oil level is at or below the low mark add the appropriate type of oil until the oil level is at the proper level. SAE 10W-30 oil is recommended for general use. (The SAE Viscosity Grade chart on page 13 in the Maintenance section shows other viscosities to use in different average temperatures.)
6. Thread the dipstick back in clockwise.

**NOTICE:** Do not run the engine with too little oil. Engine **will shut off** if engine oil level is too low.

### Checking and Filling Fuel



**WARNING!** TO PREVENT SERIOUS INJURY FROM FIRE:

Fill the fuel tank in a well-ventilated area away from ignition sources. If the engine is hot from use, shut the engine off and wait for it to cool before adding fuel. Do not smoke.

1. Clean the Fuel Cap and the area around it.
2. Unscrew and remove the Fuel Cap.
3. If needed, fill the Fuel Tank to about 1 inch under the fill neck of the Fuel Tank with 87 octane or higher unleaded gasoline that has been treated with a fuel stabilizer additive. Follow fuel stabilizer manufacturer's recommendations for use.

**Note:** Do not use gasoline containing more than 10% ethanol (E10). Do not use E85 ethanol.

**Note:** Do not use gasoline that has been stored in a metal fuel container or a dirty fuel container. It can cause particles to enter the carburetor, affecting engine performance and/or causing damage.

4. Then replace the Fuel Cap.
5. Wipe up any spilled fuel and allow excess to evaporate before starting engine. To prevent FIRE, do not start the engine while the smell of fuel hangs in the air.

## Starting the Engine

### Before Starting the Engine



- a. Follow the Set Up instructions in the equipment manual to prepare the equipment.
- b. Inspect the equipment and engine.
- c. Fill the engine with the proper amount and type of both stabilizer-treated unleaded gasoline and oil.
- d. Read the equipment operation section in the equipment manual.
- e. Move the mower to a location that is flat, level, and free from loose objects (such as rocks or sticks). The mower may be difficult to start on grass.
- f. DO NOT tempt governor setting to increase max. speed. Over speed is hazardous and will void warranty.

# OPERATION(cont.)

## Starting the Engine

1. Press the Priming Bulb 2-3 times to prime the engine.

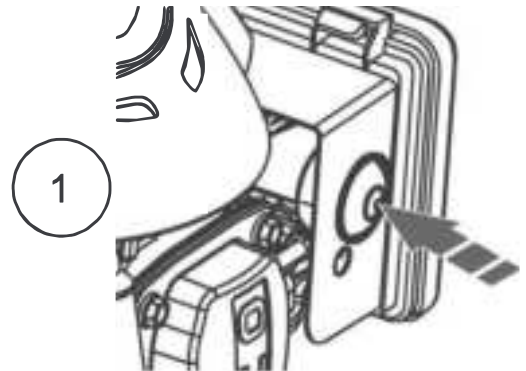

2. Adjust the Mower's Throttle control to full throttle.

**Note:** Location, operation, and design of the Throttle control will vary from manufacturer to manufacturer.

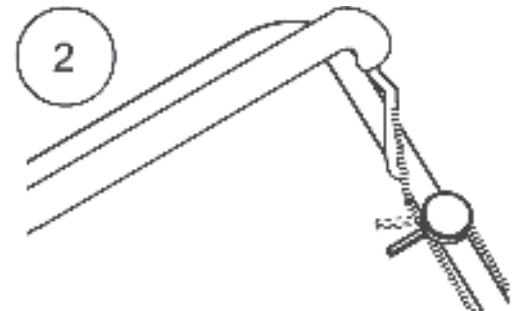

3. Hold the mower's brake handle closed.

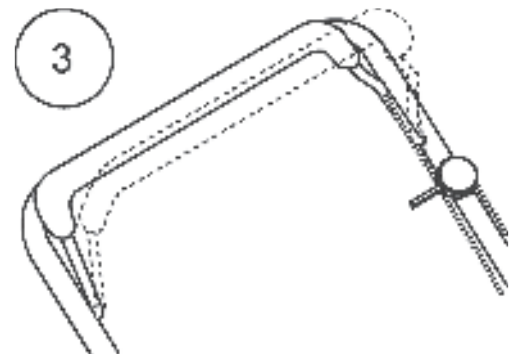

4. Grip the Starter Handle of the Engine loosely and pull it gently until resistance is felt. Allow Cable to retract fully and then pull it quickly. Repeat until the engine starts.

**Note:** Do not let the Starter Handle snap back against the engine. Hold it as it recoils so it doesn't hit the engine.

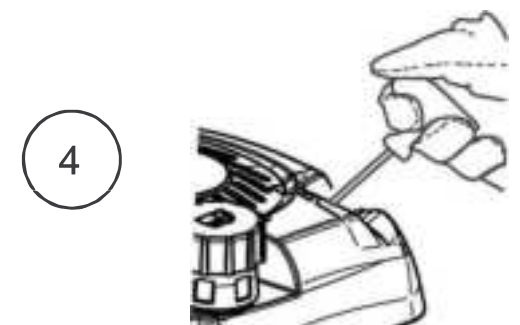

**Note:** If engine does not start, check engine oil level. Engine will not start with low or no engine oil.

5. Allow the Engine to run for several seconds. Then, the Mower's Throttle control can be adjusted as desired for operation.



**IMPORTANT:** Allow the engine to run at no load for a minute or two after each start-up so that the engine can stabilize.

## OPERATION(cont.)

---

### 6. Break-in Period:

- a. Breaking-in the engine will help to ensure proper equipment and engine operation.
- b. The operational break-in period will last about 3 hours of use. During this period:
  - Do not apply a heavy load to the equipment.
- c. The maintenance break-in period will last about 20 hours of use. After this period:
  - Change the engine oil.

Under normal operating conditions subsequent maintenance follows the schedule explained in the MAINTENANCE AND SERVICING section.

## Stopping the Engine

To stop the engine, release the brake handle.

### NOTICE

See Long-Term Storage chart on page 14 for complete storage instructions.

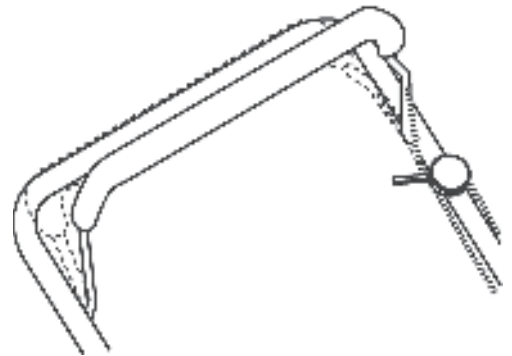

# MAINTENANCE

## **⚠️ WARNING**

### TO PREVENT SERIOUS INJURY FROM ACCIDENTAL STARTING:

Turn the Power Switch of the equipment to its “OFF” position, wait for the engine to cool, and disconnect the spark plug cap before performing any inspection, maintenance, or cleaning procedures.

### TO PREVENT SERIOUS INJURY FROM EQUIPMENT FAILURE:

Do not use damaged equipment. If abnormal noise, vibration, or excess smoking occurs, have the problem corrected before further use.

Follow all service instructions in this manual. The engine may fail critically if not serviced properly.



Many maintenance procedures, including any not detailed in this manual, will need to be performed by a qualified technician for safety. If you have any doubts about your ability to safely service the equipment or engine, have a qualified technician service the equipment instead.

## Cleaning, Maintenance, and Lubrication Schedule

**Note:** This maintenance schedule is intended solely as a general guide. If performance decreases or if equipment operates unusually, check systems immediately. The maintenance needs of each piece of equipment will differ depending on factors such as duty cycle, temperature, air quality, fuel quality, and other factors.

**Note:** The following procedures are in addition to the regular checks and maintenance explained as part of the regular operation of the engine and equipment.

Procedure	Before Each Use	Monthly or every 20 hr. of use	Every 3 mo. or 50 hr. of use	Every 6 mo. or 100 hr. of use	Yearly or every 300 hr. of use	Every 2 Years
Brush off outside of engine	✓	✓	✓	✓	✓	✓
Check engine oil level	✓	✓	✓	✓	✓	✓
Check air cleaner	✓		✓	✓	✓	✓
Check deposit cup	✓			✓	✓	✓
Change engine oil		✓		✓	✓	✓
Clean/replace air cleaner			✓*	✓	✓	✓
Check and clean spark plug				✓	✓	✓
1. Check/adjust idle speed 2. Check/adjust valve clearance 3. Clean fuel tank, strainer and carburetor 4. Clean carbon build-up from combustion chamber					✓**	✓**
Replace fuel line if necessary						✓**

\* Service more frequently when used in dusty areas.

\*\* These items should be serviced by a qualified technician.

# ***BILT HARD***

# MAINTENANCE(cont.)

## Checking and Filling Fuel



### **⚠️ WARNING! TO PREVENT SERIOUS INJURY FROM FIRE:**

Fill the fuel tank in a well-ventilated area away from ignition sources. If the engine is hot from use, shut the engine off and wait

for it to cool before adding fuel. Do not smoke.

1. Clean the Fuel Cap and the area around it.
2. Unscrew and remove the Fuel Cap.
3. If needed, fill the Fuel Tank to about 1 inch under the fill neck of the Fuel Tank with 87 octane or higher unleaded gasoline that has been treated with a fuel stabilizer additive. Follow fuel stabilizer manufacturer's recommendations for use.

**Note:** Do not use gasoline containing more than 10% ethanol (E10). Do not use E85 ethanol.

**Note:** Do not use gasoline that has been stored in a metal fuel container or a dirty fuel container. It can cause particles to enter the carburetor, affecting engine performance and/or causing damage.

4. Then replace the Fuel Cap.
5. Wipe up any spilled fuel and allow excess to evaporate before starting engine. To prevent FIRE, do not start the engine while the smell of fuel hangs in the air.

## Engine Oil Change

**⚠️ CAUTION!** Oil is very hot during operation and can cause burns. Wait for engine to cool before changing oil.

1. Make sure the engine is stopped and is level.
2. Close the Fuel Valve.
3. Place a drain pan (not included) underneath the crankcase's drain plug.
4. Remove the drain plug and, if possible, tilt the crankcase slightly to help drain the oil out. Recycle used oil.
5. Replace the drain plug and tighten it.
6. Clean the top of the Dipstick and the area around it. Remove the Dipstick by turning it counterclockwise, and wipe it off with a clean, lint free rag.

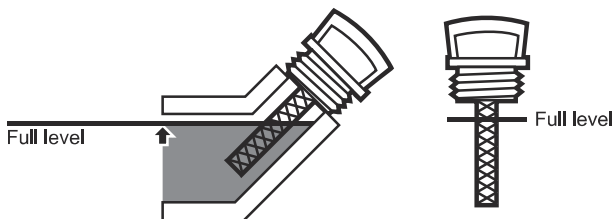

7. Add the appropriate type of oil until the oil level is at the full level. SAE 10W-30 oil is recommended for general use. The SAE Viscosity Grade chart shows other viscosities to use in different average temperatures.

## SAE Viscosity Grades

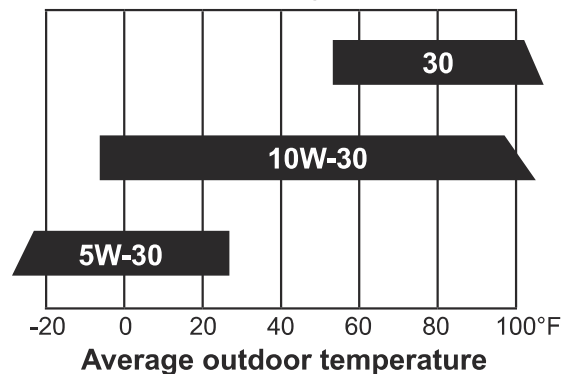

8. Thread the dipstick back in clockwise.

**NOTICE:** Do not run the engine with too little oil. Engine will not start with low or no engine oil.

## Air Filter Element Maintenance

1. Remove the air filter cover and the air filter elements and check for dirt. Clean as described below.
2. **Cleaning:**
  - For "paper" filter elements: To prevent injury from dust and debris, wear ANSI-approved safety goggles, NIOSH-approved dust mask/respirator, and heavy-duty work gloves. In a well-ventilated area away from bystanders, use pressurized air to blow dust out of the air filter.
  - For foam filter elements: Wash the element in warm water and mild detergent several times. Rinse. Squeeze out excess water and allow it to dry completely. Soak the filter in lightweight oil briefly, then squeeze out the excess oil.
3. Install the cleaned filter. Secure the Air Cleaner Cover before use.

## Spark Plug Maintenance

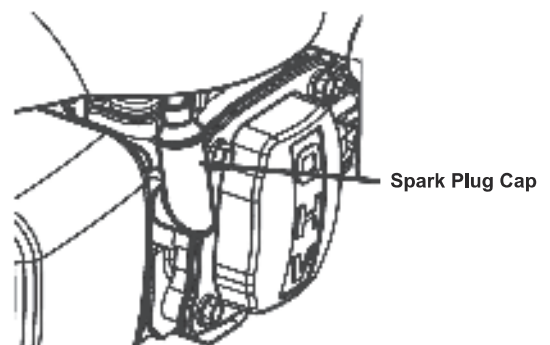

1. Disconnect spark plug cap from end of plug. Clean out debris from around spark plug
2. Using a spark plug wrench, remove the spark plug.

## MAINTENANCE(cont.)

3. Inspect the spark plug:  
If the electrode is oily, clean it using a clean, dry rag. If the electrode has deposits on it, polish it using emery paper. If the white insulator is cracked or chipped, the spark plug needs to be replaced.

Recommended Spark Plugs	
NGK®	DCPR7E
Torch®	DK7RTC
CHAMPION®	RA8HC

**NOTICE:** Using an incorrect spark plug may damage the engine.

4. When installing a new spark plug, adjust the plug's gap to the specification on the Technical Specifications chart. Do not pry against the electrode, the spark plug can be damaged.
5. Install the new spark plug or the cleaned spark plug

## Long-Term Storage

When the equipment is to remain idle for longer than 20 days, prepare the Engine for storage as follows:

### 1. CLEANING:

Wait for Engine to cool, then clean Engine with dry cloth. **NOTICE: Do not clean using water.** The water will gradually enter the Engine and cause rust damage. Apply a thin coat of rust preventive oil to all metal parts.

### 2. FUEL:

To protect the fuel tank during storage, fill the tank with gasoline that has been treated with a fuel stabilizer additive. Follow fuel stabilizer manufacturer's recommendations for use. Refer to *Checking and Filling Fuel* on page 12.



### **⚠ WARNING! TO PREVENT SERIOUS INJURY FROM FIRE:**

Fill tank in a well-ventilated area away from ignition sources. If the engine is hot from use, shut the engine off and wait for it to cool before adding fuel. Do not smoke.

- a. Place a funnel leading to a proper gasoline container below the carburetor.

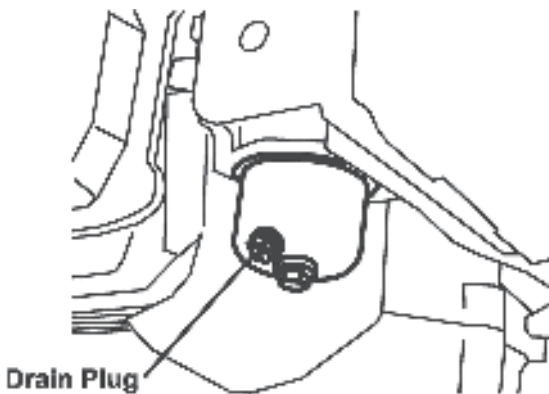

into the engine. Gasket-style: Finger-tighten until the gasket contacts the cylinder head, then tighten about 1/2-2/3 turn more.

Non-gasket-style: Finger-tighten until the plug contacts the head, then tighten about 1/16 turn more.

**NOTICE:** Tighten the spark plug properly. If loose, the spark plug will cause the engine to overheat.

If overtightened, the threads in the engine block will be damaged.

6. Apply dielectric spark plug boot protector (not included) to the end of the spark plug and reattach the wire securely.

- b. Remove the drain bolt from the bottom of the carburetor bowl and allow the fuel to drain.
- c. After all fuel has drained, reinstall the drain bolt. Tighten securely.

### 3. LUBRICATION:

- a. Change engine oil.
- b. Clean out area around spark plug.  
Remove spark plug and pour one tablespoon of engine oil into cylinder through spark plug hole.
- c. Replace spark plug, but leave spark plug cap disconnected.
- d. Pull Starter Handle to distribute oil in cylinder. Stop after one or two revolutions when you feel the piston start the compression stroke (when you start to feel resistance).

### 4. STORAGE AREA:

Cover and store in a dry, level, well-ventilated area out of reach of children. Storage area should also be away from ignition sources, such as water heaters, clothes dryers, and furnaces.

**NOTICE:** During extended storage periods the Engine must be started every 3 months and allowed to run for 15–20 minutes or the Warranty is VOID.

### 5. AFTER STORAGE:

Before starting the Engine during or after storage, keep in mind that untreated gasoline will deteriorate quickly. Drain the fuel tank and change to fresh fuel if untreated gasoline has been sitting for a month, if treated gasoline has been sitting beyond the fuel stabilizer's recommended time period, or if the Engine does not start.

# TROUBLESHOOTING

Problem	Possible Causes	Probable Solutions
Engine will not start	<b>FUEL RELATED:</b> <ol style="list-style-type: none"> <li>No fuel in tank or fuel valve closed.</li> <li>Choke not in START position, cold engine.</li> <li>Gasoline with more than 10% ethanol used. (E15, E20, E85, etc.)</li> <li>Low quality or deteriorated, old gasoline.</li> <li>Carburetor not primed.</li> <li>Dirty fuel passageways.</li> <li>Carburetor needle stuck. Fuel can be smelled in the air.</li> <li>Too much fuel in chamber. This can be caused by the carburetor needle sticking.</li> <li>Clogged Fuel Filter.</li> </ol>	<b>FUEL RELATED:</b> <ol style="list-style-type: none"> <li>Fill fuel tank with fresh 87+ octane stabilizer-treated unleaded gasoline and open fuel valve. <b>Do not use gasoline with more than 10% ethanol (E15, E20, E85, etc.).</b></li> <li>Move Choke to START position.</li> <li>Clean out ethanol rich gasoline from fuel system. Replace components damaged by ethanol. Use fresh 87+ octane stabilizer-treated unleaded gasoline only. <b>Do not use gasoline with more than 10% ethanol (E15, E20, E85, etc.).</b></li> <li>Use fresh 87+ octane stabilizer-treated unleaded gasoline. <b>Do not use gasoline with more than 10% ethanol (E15, E20, E85, etc.).</b></li> <li>Pull on Starter Handle to prime.</li> <li>Clean out passageways using fuel additive. Heavy deposits may require further cleaning.</li> <li><b>Gently</b> tap side of carburetor float chamber with screwdriver handle.</li> <li>Turn Choke to RUN position. Remove spark plug and pull the start handle several times to air out the chamber. Reinstall spark plug and set Choke to START position.</li> <li>Replace Fuel Filter.</li> </ol>
	<b>IGNITION (SPARK) RELATED:</b> <ol style="list-style-type: none"> <li>Spark plug cap not connected securely.</li> <li>Spark plug electrode wet or dirty.</li> <li>Incorrect spark plug gap.</li> <li>Spark plug cap broken.</li> <li>Incorrect spark timing or faulty ignition system.</li> </ol>	<b>IGNITION (SPARK) RELATED:</b> <ol style="list-style-type: none"> <li>Connect spark plug cap properly.</li> <li>Clean spark plug.</li> <li>Correct spark plug gap.</li> <li>Replace spark plug cap.</li> <li>Have qualified technician diagnose/repair ignition system.</li> </ol>
	<b>COMPRESSION RELATED:</b> <ol style="list-style-type: none"> <li>Cylinder not lubricated. Problem after long storage periods.</li> <li>Loose or broken spark plug. (Hissing noise will occur when trying to start.)</li> <li>Loose cylinder head or damaged head gasket. (Hissing noise will occur when trying to start.)</li> <li>Engine valves or tappets mis-adjusted or stuck.</li> </ol>	<b>COMPRESSION RELATED:</b> <ol style="list-style-type: none"> <li>Pour tablespoon of oil into spark plug hole. Crank engine a few times and try to start again.</li> <li>Tighten spark plug. If that does not work, replace spark plug. If problem persists, may have head gasket problem, see #3.</li> <li>Tighten head. If that does not remedy problem, replace head gasket.</li> <li>Have qualified technician adjust/repair valves and tappets.</li> </ol>
	<b>ENGINE OIL RELATED:</b> <ol style="list-style-type: none"> <li>Low engine oil.</li> <li>Engine mounted on slope, triggering low oil shutdown.</li> </ol>	<b>ENGINE OIL RELATED:</b> <ol style="list-style-type: none"> <li>Fill engine oil to proper level. Check engine oil before EVERY use.</li> <li>Operate engine on level surface. Check engine oil level.</li> </ol>



**Follow all safety precautions whenever diagnosing or servicing the equipment or engine.**

## TROUBLESHOOTINGS(cont.)

Problem	Possible Causes	Probable Solutions
Engine misfires	<ol style="list-style-type: none"> <li>1. Spark plug cap loose.</li> <li>2. Incorrect spark plug gap or damaged spark plug.</li> <li>3. Defective spark plug cap.</li> <li>4. Old or low quality gasoline.</li> <li>5. Incorrect compression.</li> </ol>	<ol style="list-style-type: none"> <li>1. Check cap and wire connections.</li> <li>2. Re-gap or replace spark plug.</li> <li>3. Replace spark plug cap.</li> <li>4. Use only fresh 87+ octane stabilizer-treated unleaded gasoline. <b>Do not use gasoline with more than 10% ethanol (E15, E20, E85, etc.).</b></li> <li>5. Diagnose and repair compression. (Use <b>Engine will not start: COMPRESSION RELATED</b> section.)</li> </ol>
Engine stops suddenly	<ol style="list-style-type: none"> <li>1. Fuel tank empty or full of impure or low quality gasoline.</li> <li>2. Low oil shutdown.</li> <li>3. Defective fuel tank cap creating vacuum, preventing proper fuel flow.</li> <li>4. Faulty magneto.</li> <li>5. Disconnected or improperly connected spark plug cap.</li> </ol>	<ol style="list-style-type: none"> <li>1. Fill fuel tank with fresh 87+ octane stabilizer-treated unleaded gasoline. <b>Do not use gasoline with more than 10% ethanol (E15, E20, E85, etc.).</b></li> <li>2. Fill engine oil to proper level. Check engine oil before EVERY use.</li> <li>3. Test/replace fuel tank cap.</li> <li>4. Have qualified technician service magneto.</li> <li>5. Secure spark plug cap.</li> </ol>
Engine stops when under heavy load	<ol style="list-style-type: none"> <li>1. Dirty air filter</li> <li>2. Engine running cold.</li> </ol>	<ol style="list-style-type: none"> <li>1. Clean element.</li> <li>2. Allow engine to warm up prior to operating equipment.</li> </ol>
Engine knocks	<ol style="list-style-type: none"> <li>1. Old or low quality gasoline.</li> <li>2. Engine overloaded.</li> <li>3. Incorrect spark timing, deposit buildup, worn engine, or other mechanical problems.</li> </ol>	<ol style="list-style-type: none"> <li>1. Fill fuel tank with fresh 87+ octane stabilizer-treated unleaded gasoline. <b>Do not use gasoline with more than 10% ethanol (E15, E20, E85, etc.).</b></li> <li>2. Do not exceed equipment's load rating.</li> <li>3. Have qualified technician diagnose and service engine.</li> </ol>
Engine backfires	<ol style="list-style-type: none"> <li>1. Impure or low quality gasoline.</li> <li>2. Engine too cold.</li> <li>3. Intake valve stuck or overheated engine.</li> <li>4. Incorrect timing.</li> </ol>	<ol style="list-style-type: none"> <li>1. Fill fuel tank with fresh 87+ octane stabilizer-treated unleaded gasoline. <b>Do not use gasoline with more than 10% ethanol (E15, E20, E85, etc.).</b></li> <li>2. Use cold weather fuel and oil additives to prevent backfiring.</li> <li>3. Have qualified technician diagnose and service engine.</li> <li>4. Check engine timing.</li> </ol>
After sudden impact, engine will run, but equipment will not operate	<p>Shaft key or other shear pin broken by impact to disconnect engine and limit damage.</p>	<p>Have qualified technician check and replace broken shaft key or other shear pins.</p>



**Follow all safety precautions whenever diagnosing or servicing the equipment or engine.**

## **California and Federal Exhaust and Evaporative Emissions Control Warranty Statement**

### **YOUR WARRANTY RIGHTS AND OBLIGATIONS**

The California Air Resources Board, the United States Environmental Protection Agency and Du Du Group (Du Du) are pleased to explain the exhaust and evaporative emissions (“emissions”) control system warranty on your **2021/2022** small off-road engine/equipment. In California, new equipment that use small off-road engines must be designed, built, and equipped to meet the State’s stringent anti-smog standards. Du Du must warrant the emissions control system on your small off-road engine/equipment for the period listed below provided there has been no abuse, neglect or improper maintenance of your small off-road engine/equipment leading to the failure of the emissions control system.

Your emissions control system may include parts such as the carburetor or fuel-injection system, the ignition system, catalytic converter, fuel tanks, fuel lines (for liquid fuel and fuel vapors), fuel caps, valves, canisters, filters, clamps and other associated components. Also included may be hoses, belts, connectors, and other emission-related assemblies.

Where a warrantable condition exists, Du Du will repair your small off-road engine/equipment at no cost to you including diagnosis, parts and labor.

### **MANUFACTURER'S WARRANTY COVERAGE:**

The exhaust and evaporative emissions control system on your small off-road engine/equipment is warranted for two years. If any emissions-related part on your small off-road engine/equipment is defective, the part will be repaired or replaced by Du Du.

### **OWNER'S WARRANTY RESPONSIBILITIES:**

As the small off-road engine/equipment owner, you are responsible for performance of the required maintenance listed in your owner's manual. Du Du recommends that you retain all receipts covering maintenance on your small off-road engine/equipment, but Du Du cannot deny warranty coverage solely for the lack of receipts or for your failure to ensure the performance of all scheduled maintenance.

As the small off-road engine/equipment owner, you should however be aware that Du Du may deny you warranty coverage if your small off-road engine/equipment or a part has failed due to abuse, neglect, or improper maintenance or unapproved modifications.

You are responsible for presenting your small off-road engine/equipment to a Du Du distribution center or service center as soon as the problem exists. The warranty repairs shall be completed in a reasonable amount of time, not to exceed 30 days.

If you have any questions regarding your warranty rights and responsibilities, you should contact Du Du Du Group (888)680-2849 or [inquiry@bilthardusa.com](mailto:inquiry@bilthardusa.com).

### **DEFECTS WARRANTY REQUIREMENTS:**

- (a) The warranty period begins on the date the small off-road engine/equipment is delivered to an ultimate purchaser.
- (b) General Emissions Warranty Coverage. Du Du warrants to the ultimate purchaser and each subsequent owner that the engine or equipment is:
  - (1) Designed, built, and equipped so as to conform with all applicable regulations adopted by the Air Resources Board; and
  - (2) Free from defects in materials and workmanship that causes the failure of a warranted part for a period of two years.
- (c) The warranty on emission-related parts will be interpreted as follows:
  - (1) Any warranted part that is not scheduled for replacement as required maintenance in the written instructions must be warranted for the warranty period defined in Subsection (b)(2). If any such part fails during the period of warranty coverage, it must be repaired or replaced by Du Du according to Subsection (4) below. Any such part repaired or replaced under the warranty must be warranted for the remaining warranty period.
  - (2) Any warranted part that is scheduled only for regular inspection in the written instructions must be warranted for the warranty period defined in Subsection (b)(2). A statement in such written instructions to the effect of “repair or replace as necessary” shall advise owners of the warranty coverage for emissions related parts. Replacement within the warranty period is covered by the warranty and will not reduce the period of warranty coverage. Any such part repaired or replaced under warranty must be warranted for the remaining warranty period.
  - (3) Any warranted part that is scheduled for replacement as required maintenance in the written instructions must be warranted for the period of time prior to the first scheduled

## WARRANTY (cont.)

---

- replacement point for that part. If the part fails prior to the first scheduled replacement, the part must be repaired or replaced by Du Du according to Subsection (4) below. Any such part repaired or replaced under warranty must be warranted for the remainder of the period prior to the first scheduled replacement point for the part.
- (4) Repair or replacement of any warranted part under the warranty provisions must be performed at no charge to the owner at a warranty station.
  - (5) Notwithstanding the provisions of Subsection (4) above, warranty services or repairs must be provided at distribution centers that are franchised to service the subject engine/equipment.
  - (6) The owner must not be charged for diagnostic labor that leads to the determination that a warranted part is in fact defective, provided that such diagnostic work is performed at a warranty station.
  - (7) Du Du is liable for damages to other engine/equipment components proximately caused by a failure under warranty of any warranted part.
  - (8) Throughout the emissions control system's warranty period set out in subsection (b)(2), Rato must maintain a supply of warranted parts sufficient to meet the expected demand for such parts and must obtain additional parts if that supply is exhausted.
  - (9) Manufacturer-approved replacement parts that do not increase the exhaust or evaporative emissions of the engine or emissions control system must be used in the performance of any warranty maintenance or repairs and must be provided without charge to the owner. Such use will not reduce the warranty obligations of Du Du.
  - (10) Add-on or modified parts that are not exempted by the Air Resources Board may not be used. The use of any non-exempted add-on or modified parts will be grounds for disallowing a warranty claim. Du Du will not be liable to warrant failures of warranted parts caused by the use of a non-exempted add-on or modified part.
  - (11) Du Du issuing the warranty shall provide any documents that describe that warranty procedures or policies within five working days of request by the Executive Officer.
- (d) Emission Warranty Parts List for Exhaust
- (1) Fuel Metering System
    - (i) Carburetor and internal parts (and/or pressure regulator or fuel injection system).
    - (ii) Air/fuel ratio feedback and control system.
    - (iii) Cold start enrichment system.
  - (2) Air Induction System
    - (i) Controlled hot air intake system.
    - (ii) Intake manifold.
    - (iii) Air filter.
  - (3) Ignition System
    - (i) Spark Plugs.
    - (ii) Magneto or electronic ignition system.
    - (iii) Spark advance/retard system.
  - (4) Exhaust Gas Recirculation (EGR) System
    - (i) EGR valve body, and carburetor spacer if applicable.
    - (ii) EGR rate feedback and control system.
  - (5) Air Injection System
    - (i) Air pump or pulse valve.
    - (ii) Valves affecting distribution of flow.
    - (iii) Distribution manifold.
  - (6) Catalyst or Thermal Reactor System
    - (i) Catalytic converter.
    - (ii) Thermal reactor.
    - (iii) Exhaust manifold.
  - (7) Particulate Controls
    - (i) Traps, filters, precipitators, and any other device used to capture particulate emissions.
  - (8) Miscellaneous Items Used in Above Systems
    - (i) Electronic controls.
    - (ii) Vacuum, temperature, and time sensitive valves and switches.
    - (iii) Hoses, belts, connectors, and assemblies.
- (e) Emission Warranty Parts List for Evap
- (1) Fuel Tank
  - (2) Fuel Cap
  - (3) Fuel Lines (for liquid fuel and fuel vapors)
  - (4) Fuel Line Fittings
  - (5) Clamps\*
  - (6) Pressure Relief Valves\*
  - (7) Control Valves\*
  - (8) Control Solenoids\*
  - (9) Electronic Controls\*
  - (10) Vacuum Control Diaphragms\*
  - (11) Control Cables\*
  - (12) Control Linkages\*
  - (13) Purge Valves\*
  - (14) Gaskets\*
  - (15) Liquid/Vapor Separator
  - (16) Carbon Canister
  - (17) Canister Mounting Brackets
  - (18) Carburetor Purge Port Connector
- \*Note: As they relate to the evaporative emission control system.
- Du Du will furnish with each new small off-road engine/equipment written instructions for the maintenance and use of the engine/equipment by the owner.

## PLEASE READ THE FOLLOWING CAREFULLY

---

The manufacture and/or distributor has provided the parts list and assembly diagram in this manual as a reference tool only. Neither the manufacturer or distributor makes any representation or warranty of any kind to the buyer that he or she is qualified to make any repairs to the product, or that he or she is qualified to replace any parts of the product. In fact, the manufacturer and/or distributor expressly states that all repairs and parts replacements should be undertaken by certified and licensed technicians, and not by the buyer. the buyer assumes all risk and liability arising out of his or her repairs to the original product or replacement parts thereto, or arising out of his or her installation of replacement parts thereto.

# Parts List and Diagram

**FIG.1 CRANKCASE. / GEAR ASSY, GOVERNOR.**

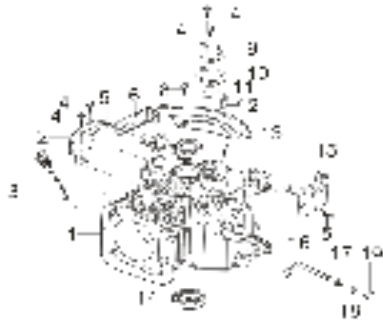

REF.NO.	PART NO	DESCRIPTION	Q'TY
E01-1	11310-Z340520-00A9	CRANKCASE SUBASSEMBLY.	1
E01-2	19308-Z030110-0000	BODY LEFT SHIELD	1
E01-3	15010-Z030130-Q500	DIPSTICK SUBASSEMBLY, OIL	1
E01-4	90007-0612-A1A0	BOLT	4
E01-5	90007-0612-A1A0	BOLT	2
E01-6	16608HZ030120-0000	BRACKET, FUEL TANK RIGHT	1
E01-7	90682-Z030120-0000	SEAL, OIL	1
E01-8	90007-0612-A1A0	BOLT	1
E01-9	11333-Z250210-00A0	PLATE, BREATH GROOVE COVER	1
E01-10	11332-Z250410-0000	GASKET, BREATH GROOVE	1
E01-11	11321-Z030110-00A9	BREATH SHEET	1
E01-12	11331-Z250110-00A0	STRAINER, BREATH GROOVE	1
E01-13	19351-Z030120-0000	SHIELD, CRANKCASE REAR	1
E01-14	90548-0205-CLA0	DEEP GROOVE BALL BEARING	1
E01-15	16607HZ030120-0000	BRACKET, FUEL TANK LEFT	1
E01-16	16061-Z030120-0000	ARM, GOVERNOR	1
E01-17	90408-Z010210-00A0	FLAT WASHER	1
E01-18	90682-Z030210-0000	SEAL, OIL	1
E01-19	90501-Z010110-0000	COTTER PIN	1

**FIG.2 COVER SUBASSEMBLY, CRANKCASE**



REF.NO.	PART NO	DESCRIPTION	Q'TY
E02-1	11001-Z340110-0000	GASKET, CRANKCASE	1
E02-2	90502-0812-00A0	POSITION PIN - TYPE A	2
E02-3	90408-Z030210-00A0	FLAT WASHER	1
E02-4	11341-Z030110-0000	BLOCK, RETURNING OIL	1
E02-5	90007-0612-A1A0	BOLT	1
E02-6	16013-Z030120-00A0	PLATE, GOVERNOR SPINDLE COMPRESSION	1
E02-7	90682-Z030320-0000	SEAL, OIL	1
E02-8	90001-0850-01A0	BOLT	6
E02-9	16400-Z030110-00A0	GEAR ASSY, GOVERNOR	1
E02-10	11411-Z340610-0000	COVER, CRANKCASE	1

**FIG.3 HEAD SUBASSEMBLY, CYLINDER / PLUG, SPARK**



REF.NO.	PART NO	DESCRIPTION	Q'TY
E03-1	12411-Z030120-0000	COVER, CYLINDER HEAD	1
E03-2	12004-Z030110-0000	CYLINDER HEAD COVER GASKET	1
E03-3	12140-Z390210-00A0	HEAD SUBASSEMBLY, CYLINDER	1
E03-4	12131-Z340310-0000	GASKET, CYLINDER HEAD	1
E03-5	90007-0612-A1A0	HEXAGON SOCKET FLANGE FACE BOLT - BIG SERIES - GRADE B	4
E03-6	30010-Z030310-00A0	PLUG, SPARK	1
E03-7	12003-Z030110-0000	CYLINDER HEAD BOLT	4
E03-8	18006-Z030110-0000	BRACKET, MUFFLER SHIELD	1
E03-9	90007-0612-A1A0	HEXAGON SOCKET FLANGE FACE BOLT - BIG SERIES - GRADE B	1
E03-10	90204-Z030110-00A0	STUD BOLT	2
E03-11	90502-1014-00A0	POSITION PIN - TYPE A	2
E03-12	90204-Z250310-00A0	STUD BOLT	2

**FIG.4 ROD, CRANKSHAFT CONNETING**

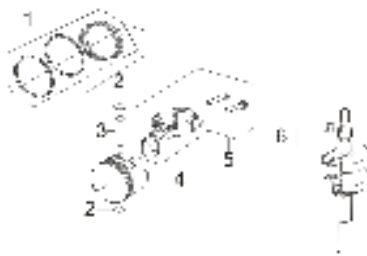

REF.NO.	PART NO	DESCRIPTION	Q'TY
E04-1	13200-Z140210-00A9	RING ASSY, PISTON	1
E04-2	13122-Z350110-00A0	CLIP, PISTON PIN	2
E04-3	13121-Z810110-0000	PIN, PISTON	1
E04-4	13111-Z810120-00A0	PISTON	1
E04-5	13010-Z390210-00A1	ROD, CONNECTING	1
E04-6	13300-Z341410-0000	CRANKSHAFT ASSY.	1

**FIG.5 TRAIN, VALVE / CAMSHAFT SUBASSEMBLY**

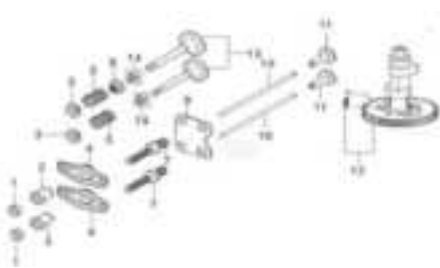

REF.NO.	PART NO	DESCRIPTION	Q'TY
E06-1	14312-Z010110-00A0	NUT, VALVE LOCK	2
E06-2	14314-Z010110-00A0	NUT, VALVE ADJUSTING	2
E06-3	12112-Z810210-00A0	SEAT, VALVE SPRING	2
E06-4	14311-Z010110-00A0	ROCKER, VALVE	2
E06-5	12103-Z030110-00A0	SPRING, VALVE	2
E06-6	12101-Z810210-00A0	GUIDE, SEAL	1
E06-7	14313-Z010110-00A0	ROCKSHAFT BOLT	2
E06-9	14091-Z340110-0000	PLATE SUBASSEMBLY, LIFTER STOPPER	1
E06-10	14071-Z440110-00A0	LIFTER, VALVE	2
E06-11	14081-Z010110-0000	TAPPET, VALVE	2
E06-12	14200-Z340310-00A9	CAMSHAFT ASSY.	1
E06-13	12110-Z390110-00A0	VALVES SET	1
E06-14	12109-Z810110-00A0	CLAMP, VALVE LOCK	4

**FIG.6 STARTER, RECOIL**



REF.NO.	PART NO	DESCRIPTION	Q'TY
E07-1	90305-0600-31A0	HEXAGON NUT WITH FLANGE	3
E07-2	28200-Z251710-Q200	STARTER ASSY, RECOIL	1

# Parts List and Diagram(cont.)

**FIG.7 SHIELD,FAN**

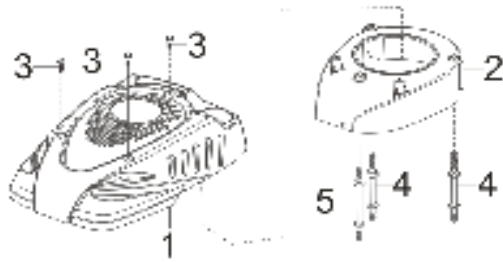

REF.NO.	PART NO	DESCRIPTION	Q'TY
E08-1	80001-Z030110-SP00	HOUSING, ENGINE	1
E08-2	28110-Z030220-00A0	SHROUD	1
E08-3	90001-0514-01A0	HEXAGON SOCKET FLANGE FACE BOLT - SMALL SERIES	3
E08-4	28001-Z030110-00A0	DOUBLE HEAD SUPPORT BOLT	2
E08-5	28001-Z030220-00A0	DOUBLE HEAD SUPPORT BOLT	1

**FIG.8 CARBURETOR ASSY.**



REF.NO.	PART NO	DESCRIPTION	Q'TY
E09-1	16004-Z030110-00A0	GASKET, INSULATOR PLATE	1
E09-2	16003-Z030110-00A0	PLATE, CARBURETOR INSULATOR	1
E09-3	16001-Z010110-0000	CARBURETOR SEAL GASKET	2
E09-4	16002-Z340410-0000	GASKET, CARBURETOR INSULATOR	1
E09-5	16100-Z341210-00M1	CARBURETOR ASSY.	1
E09-6	16210-Z250120-00A0	VALVE, STARTING RICHED	1
E09-7	16211-Z250110-0000	TUBE, STARTING RICHED VALVE	1
E09-8	90685-0700-01	PIPE CLAMP	2
E09-27	17001-Z030120-0000	AIR CLEANER SEAL GASKET	1

**FIG.9 FLYWHEEL / IMPELLER / STARTER PULLEY / IGNITION COIL**

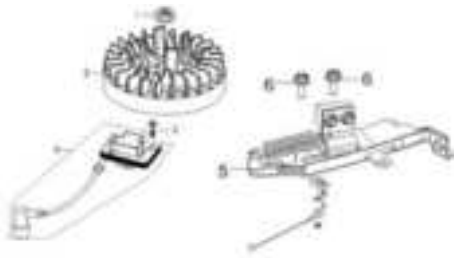

REF.NO.	PART NO	DESCRIPTION	Q'TY
E10-1	13501-Z010110-00A0	NUT, FLYWHEEL	1
E10-2	13510-Z030111-00A0	FLYWHEEL SUBASSEMBLY	1
E10-3	90007-0625-A1A0	BOLT	1
E10-4	30400-Z030210-0000	COIL, IGNITION	1
E10-5	45200-Z340310-0000	BRAKE ASSY.	1
E10-6	90007-0612-A1A0	BOLT	2

**FIG.10 CONTROL ASSY, THROTTLE**

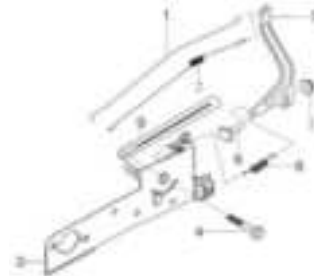

REF.NO.	PART NO	DESCRIPTION	Q'TY
E11-1	16062-Z030110-00A0	ROD, GOVERNEFOR	1
E11-2	16012-Z030120-00A0	SPRING, THROTTLE VALVE RETURNING	1
E11-3	16520-Z030130-0000	CONTROL ASSY, THROTTLE	1
E11-4	90007-0628-A1A0	BOLT	1
E11-5	16070-Z030130-0000	GOVERNOR BRACKET SUBASSEMBLY	1
E11-6	16072-Z010110-00A0	BOLT, GOVERNOR SUPPORT	1
E11-7	90305-0600-31A0	HEXAGON NUT WITH FLANGE	1
E11-8	16063-Z340110-0000	SPRING, GOVERNOR	1
E11-9	90684-Z030120-0000	WIRE CLIP	1

**FIG.11 CLEANER, AIR**

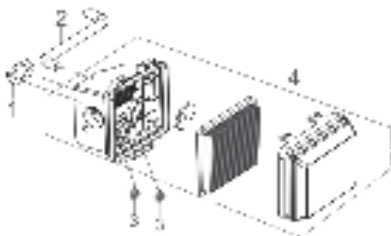

REF.NO.	PART NO	DESCRIPTION	Q'TY
F01-1	17001-Z030120-0000	AIR CLEANER SEAL GASKET	1
F01-2	17004-Z030310-00A0	TUBE, BREATHER	1
F01-3	90305-0600-31A0	HEXAGON NUT WITH FLANGE	2
F01-4	17100-Z250230-0000	AIR CLEANER	1

**FIG.12 MUFFLER ASSY.**

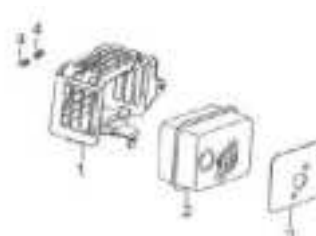

REF.NO.	PART NO	DESCRIPTION	Q'TY
F02-1	18130-Z030520-H700	MUFFLER OUTER COVER	1
F02-2	18100-Z340210-QAA1	MUFFLER ASSY.	1
F02-3	18001-Z340510-00A0	GASKET, EXHAUST OUTLET	1
F02-4	90305-0600-31A0	NUT	2

**FIG.13 TANK ASSY, FUEL**

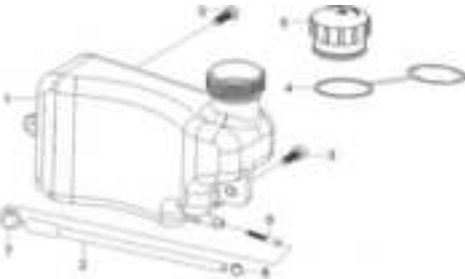

REF.NO.	PART NO	DESCRIPTION	Q'TY
F03-1	16620-Z030510-00M0	FUEL TANK	1
F03-2	90686-Z030310-00M0	TUBE, FUEL	1
F03-3	90007-0616-A1A0	HEXAGON SOCKET FLANGE FACE BOLT - BIG SERIES - GRADE B	2
F03-4	16744-Z620120-00A0	CHAIN PROOF OFF. FUEL TANK COVER	1
F03-5	16730-Z620210-LKD0	COVER, FUEL TANK	1
F03-6	16652-Z030110-00A0	STRAINER, FUEL	1
F03-7	90685-D105-0EA0	PIPE CLAMP	1
F03-8	90685-D075-0EA0	PIPE CLAMP	1

# Mounting Hole Diagram

**Note:** Not to scale.

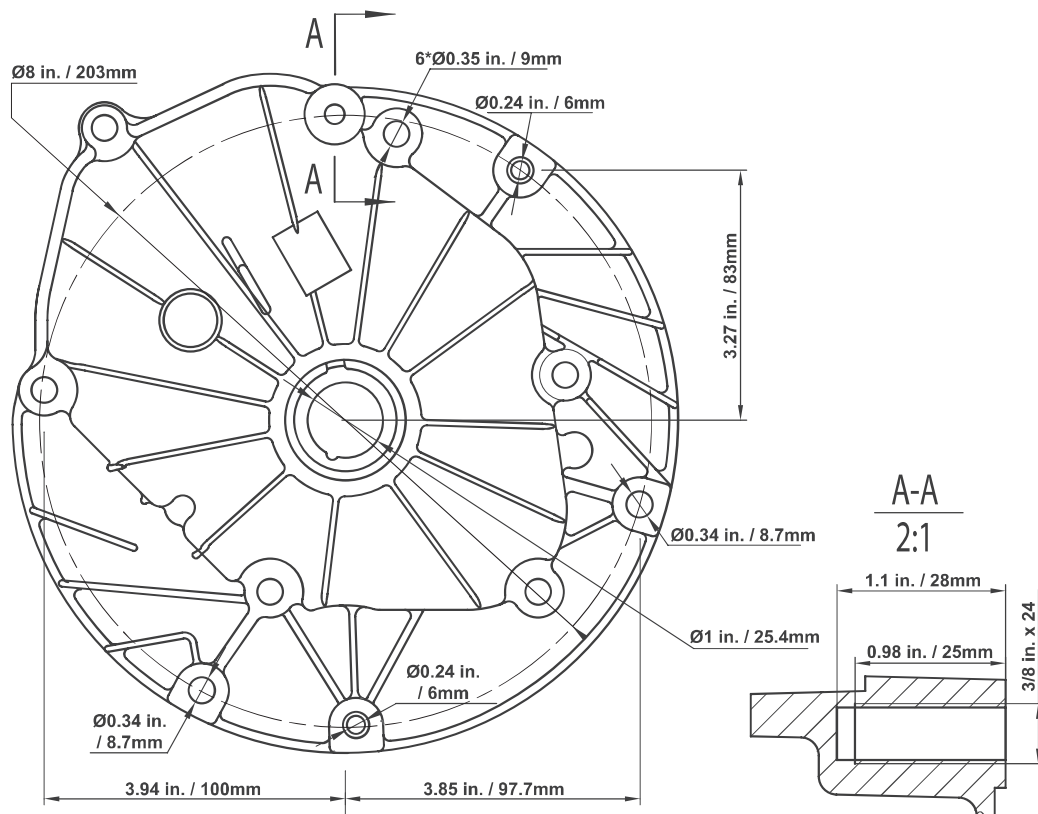

# Power Take-Off Diagram

**Note:** Not to scale.

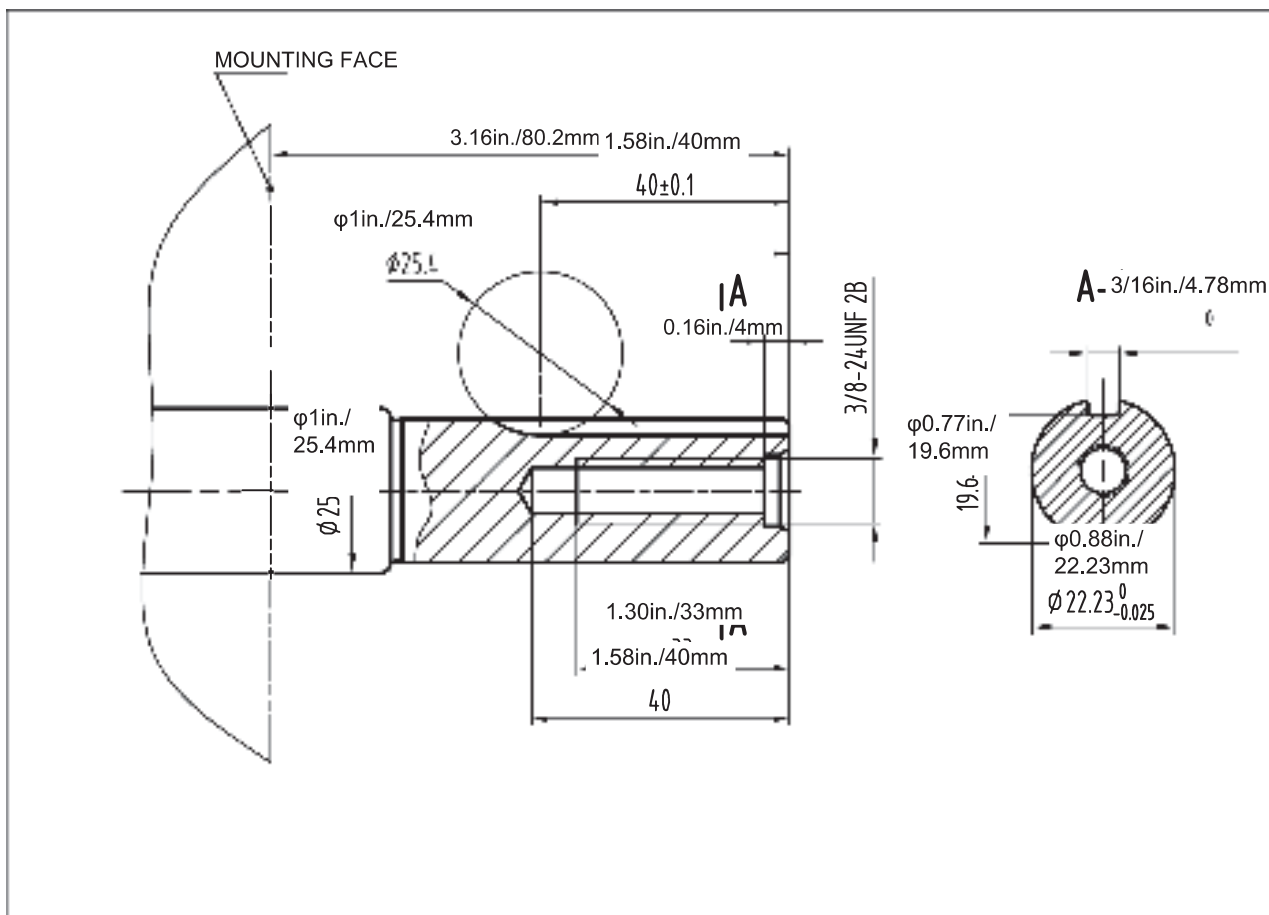



***BILT HARD***