

**Bedienungsanleitung**  
**Operating instructions**  
**Instructions d'emploi**  
**Instrucciones de servicio**  
**Manual de instruções**  
**Istruzioni d'uso**  
**Gebruiksaanwijzing**  
**Betjeningsvejledning**  
**Bruksanvisning**  
**Brukerveiledningen**  
**Käyttöohje**  
**Οδηγία χειρισμού**  
**Kullanım kılavuzu**



**BOSCH**

# **AQUATAK 110**

# **AQUATAK 110 PLUS**

# **AQUATAK 115 PLUS**

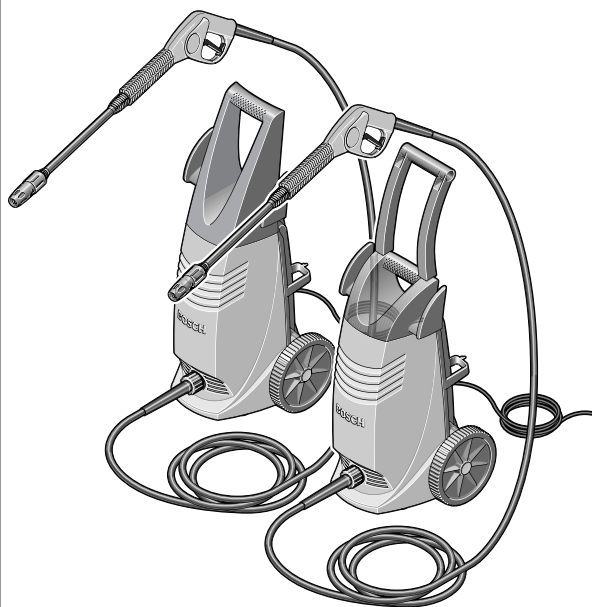

**Deutsch**  
**English**  
**Français**  
**Español**  
**Português**  
**Italiano**  
**Nederlands**  
**Dansk**  
**Svenska**  
**Norsk**  
**Suomi**  
**Ελληνικά**  
**Türkçe**





Made in Italy, Robert Bosch GmbH, D-70746, Leinfelden 579  
 Type 0XXXXXXX XXXXXXXX  
 work press XXX bar  
 max press XXX bar  
 230V 50 Hz XX kW  
 max X l/min I-XX  
 H<sub>2</sub>O T<sub>max</sub>XX °C

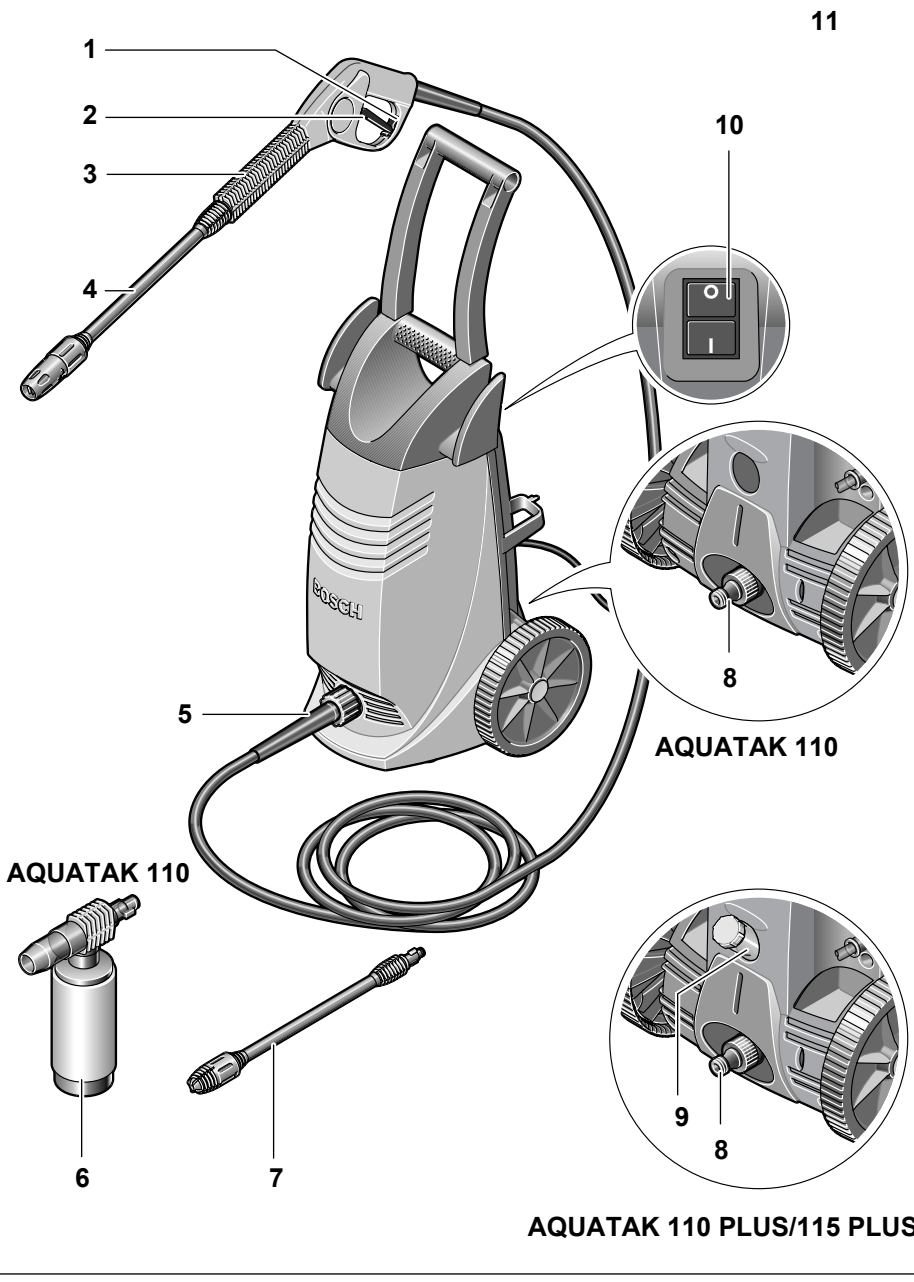

**AQUATAK 110**

**AQUATAK 110**

**AQUATAK 110 PLUS/115 PLUS**

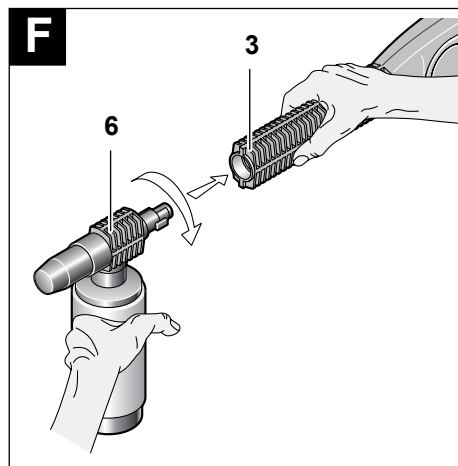
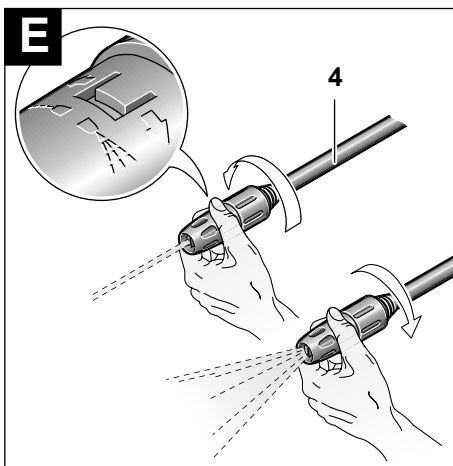
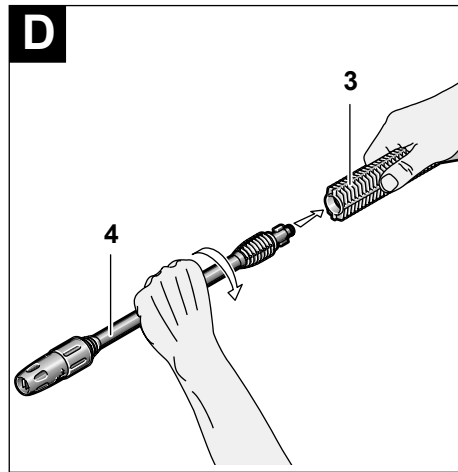
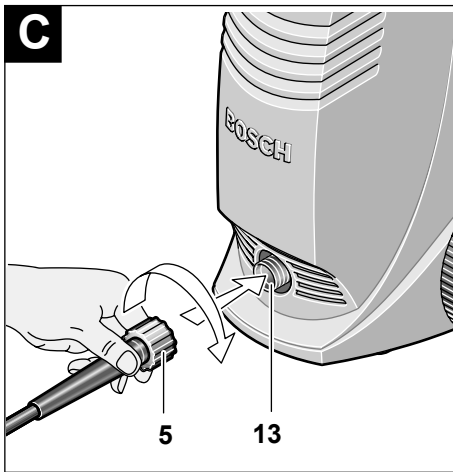
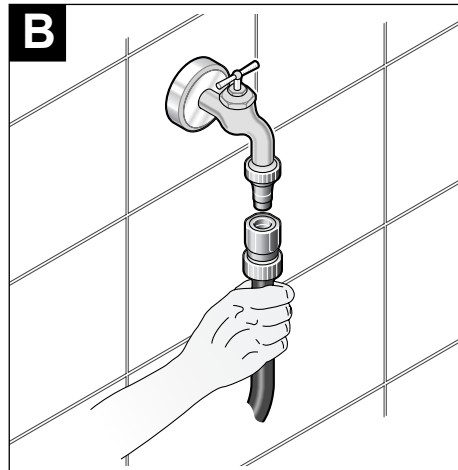
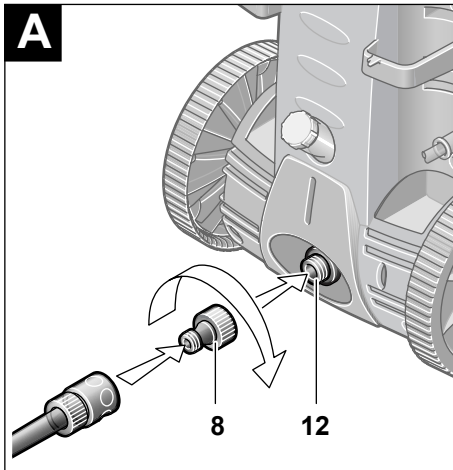

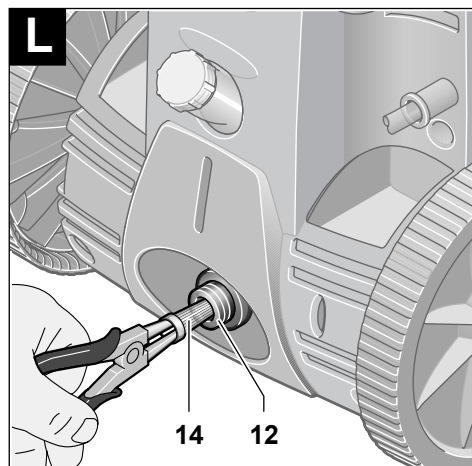
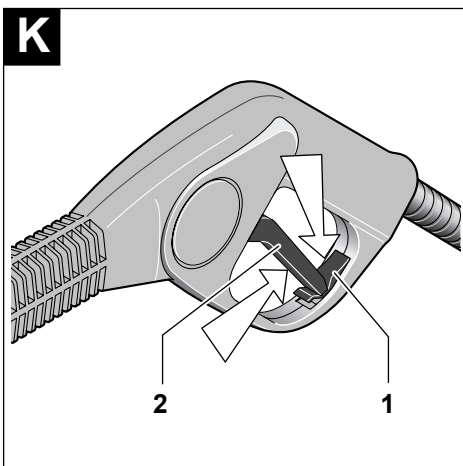
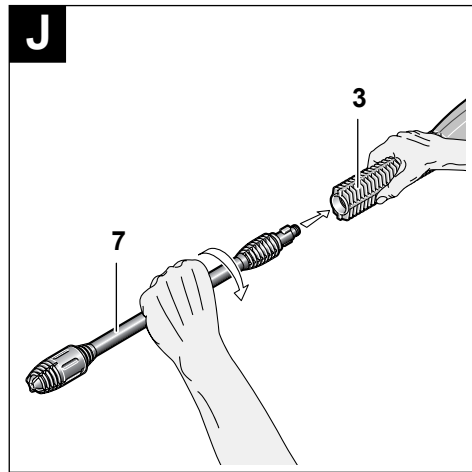
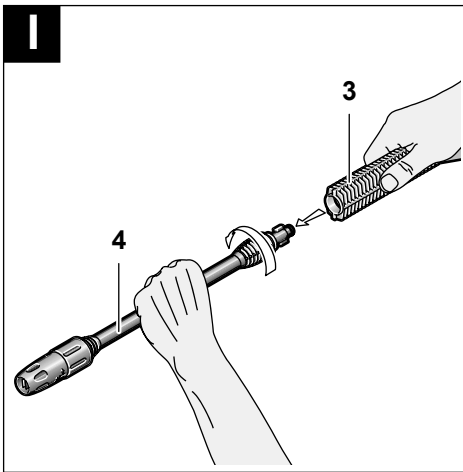
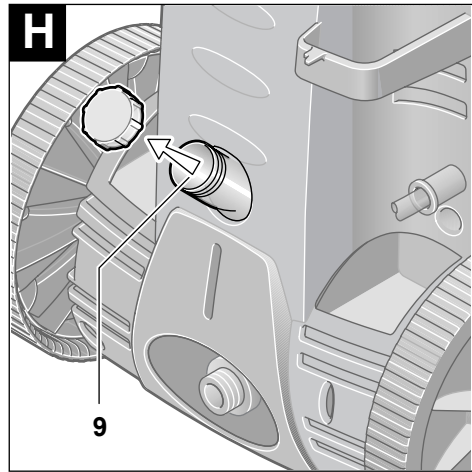
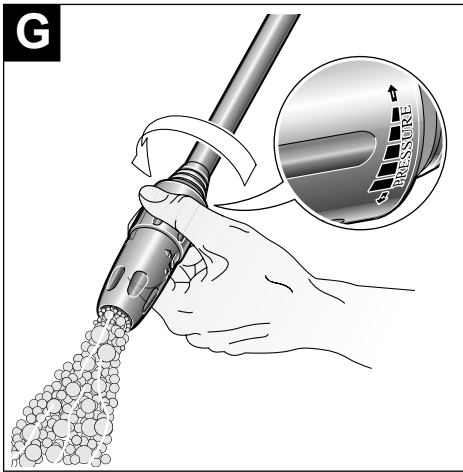



## Safety Notes



**Before start-up please read these instructions!**



**Before using the machine please read the operating instructions for your unit and comply in particular with these safety instructions.**

The warning and information signs attached to the unit provide important information for safe operation.

Apart from the information in the operating instructions comply with the general safety regulations and regulations for the prevention of accidents.

### Power Supply



Never direct the water jet at people, animals, the unit or electric components.

- The voltage indicated on the rating plate must correspond to the voltage of the power source.
- We recommend that this equipment is only connected into a socket which is protected by a circuit-breaker that would be actuated by a 30 mA residual current.
- Only use or replace power supply cables for this unit which correspond to the types indicated by the manufacturer. See the operating instructions for the order no. and types.
- If the plug is damaged, pay attention to the following:
- Plugs and sockets conforming to BS 4243 or BS 196 should be used wherever practicable. Domestic pattern plugs to BS 1363 are not recommended but if their use is essential those which have barriers or moulded channels inside should be selected so that if the earth continuity conductor is pulled out of its terminal it is unlikely to be able to touch the phase terminal of the fuse carrier. Domestic pattern plugs to BS 546 should not be used. The wiring of the plug should leave more slack in the earth continuity conductor than in the other cores, so that it is not the first core to be pulled out of its terminal should the cord grip fail. Plugs which have good grips capable of maintaining a firm hold on the cable sheath should be selected. In general, additional means should be provided to relieve stress on cable terminations in the plug. For example, additional cable clamps should be fitted or a substantial chain could be used to tether the machine to a fixed point.
- Plugs and sockets situated near the work site or outdoors should be to class IP55 of BS 5490 to provide adequate protection against ingress of water, etc. and cable entries require effective sealing. Rubber shrouds should be provided over cable glands. Drip-proof (class IP X2 of BS 5490) plugs and sockets to BS 4343 are suitable for use indoors where the plug is away from the water spray area where the appliance is in use.
- Never touch the mains plug with wet hands.
- Do not run over, crush or pull the power supply cable or extension lead, otherwise it may be damaged. Protect the cable from heat, oil and sharp edges.
- The extension lead must have a cross section in accordance with the operating instructions and be protected against splashed water. The connection must not be in water.
- When replacing couplings on the power supply cable or extension lead the spray water guard and mechanical stability must remain intact.

### Water connection

- Comply with the regulations of your water supply company.
- All connecting hoses must have properly sealed joints.
- The high-pressure hose must not be damaged (danger of bursting). A damaged high-pressure hose must be replaced immediately. Only use hoses and connections recommended by the manufacturer.

### Application

- Before use, check that the unit and operating equipment are in perfect condition and are safe to operate. Do not use the unit if it is not in perfect condition.
- Never draw in solvent-containing liquids, undiluted acids or solvents! This includes petrol, paint thinners heating oil. The sprayed vapour is highly flammable, explosive and toxic; also acetone, undiluted acids and solvents as these corrode the materials used on the unit.
- The appropriate safety regulations must be observed when using the unit in dangerous area (e.g. petrol stations). It is forbidden to operate the unit in potentially explosive locations.
- The unit must be placed on solid base.
- Only use detergents recommended by the manufacturer and comply with the application, disposal and warning instructions of the detergent manufacturers.
- All current-conducting components in the working area must be protected against splashed water.
- The gun trigger must not be jammed in position during operation.
- Suitable protective clothing must be worn if necessary to protect against splashing from some parts.
- If necessary wear personal protective equipment (PPE) e.g. safety goggles, breathing protection etc. to protect against water, particles and/or aerosols sprayed back from parts.
- High pressure may cause objects to rebound. If necessary wear suitable personnel protective equipment such as safety goggles.
- Vehicle tyres/tyre valves may only be cleaned from a minimum distance of 30 cm, otherwise the vehicle tyre/tyre valve could be damaged by the high-pressure jet. The first indication of this is a discoloration of the tyre. Damaged vehicle tyres/tyre valves can be deadly dangerous.
- Materials containing asbestos and other materials which contain substances which are hazardous to your health must not be sprayed.
- Only use detergents which have been approved by the manufacturer of the unit.
- Detergents must not be used undiluted. The products are safe to use as they contain no acids, alkalis or substances which are detrimental to the environment. We recommend that the detergents are kept out of the reach of children. If detergent comes into contact with the eyes wash immediately with plenty of water and if swallowed contact a doctor immediately.

### Operation

- The operator must use the unit in accordance with the regulations. He/she must take local conditions into account and be aware of other people, especially children, when operating the unit.
- The unit may only be used by authorised persons who have received training or have demonstrated their ability to operate the unit. The unit must not be operated by children or juveniles (danger of accidents due to incorrect use of the unit).
- The unit must never be left unsupervised while the motor is running.
- The water jet from the high-pressure nozzle produces a recoil on the gun. You should therefore hold the gun and spray lance firmly.

### Transport

- Switch off the motor and secure the unit before transporting.

### Maintenance

- Switch off the unit prior to all cleaning and maintenance work and before replacing components. Pull out the mains plug if the unit is mains-operated.
- Repairs may only be carried out by authorised Bosch Service Centres.

**Accessories and spare parts**

- Only use accessories and spare parts which have been approved by Bosch. Original accessories and spare parts guarantee that the unit can be operated safely and without any breakdowns.

**Product Specification**

Power washer		AQUATAK 110	AQUATAK 110 PLUS	AQUATAK 115 PLUS
Part number		3 600 H76 C..	3 600 H76 D..	3 600 H76 E..
Rated power	[W]	1 600	1 600	1 700
Supply Temperature max.	[°C]	40	40	40
Supply rate min.	[l/h]	17	17	17
Supply pressure max.	[bar]	1.5–6.0	1.5–6.0	1.5–6.0
Working pressure	[bar]	100	100	105
Max. Operating pressure	[bar]	110	110	115
Flow rate	[l/h]	360	380	380
Detergent Bottle or Tank		Bottle	Tank	Tank
Detergent capacity	[l]	0.5	0.75	0.75
Weight	[kg]	7.0	7.0	7.0
Protection class		□ / II	□ / II	□ / II
Serial Number	See serial No 11 (rating plate) on product.			

**Intended Use**

The product is intended for cleaning areas and objects outside the house, tools, vehicles and boats. Drainage pipes can be unclogged and rust or paint coatings can be removed, if the appropriate accessories such as cleaning agents approved by Bosch are used.

Intended Use is related to operation within 0 °C and 40 °C ambient temperature.

This product should not be used for professional use.

**Introduction**

This manual gives instructions on the correct assembly and safe use of your machine. It is important that you read these instructions carefully.

When fully assembled the machine weighs approximately 7,0 kg. If necessary, obtain assistance to remove from packaging.

**Delivered Items**

Carefully remove the machine from its packaging and check that you have all the following items:

- Power washer
- Power gun/high pressure hose
- Detergent nozzle and bottle (AQUATAK 110 only)
- Vario-jet-fan power lance (red colour coded)
- Roto power lance (red colour coded)

- Inlet Connector
  - Wash Brush (AQUATAK 110 PLUS/115 PLUS only)
  - Operating instructions
- When parts are missing or damaged, please contact your dealer.

**Operating Controls**

- Trigger safety lock
- Trigger
- Power gun
- Vario-jet-fan power lance
- High pressure hose
- Detergent nozzle and bottle (AQUATAK 110 only)
- Roto power lance
- Inlet Connector
- Detergent Tank (AQUATAK 110 PLUS/115 PLUS only)
- Main switch
- Serial Number

**Not all of the accessories illustrated or described are included as standard delivery.**



## For Your Safety

**Warning! Switch off, remove plug from mains before adjusting, cleaning or if cable is cut, damaged or entangled.**

### Electrical Safety

Your machine is double insulated for safety and requires no earth connection. The operating voltage is 230 V AC, 50 Hz (for non-EU countries 220 V, 240 V as applicable). Only use approved extension cables. Contact your Bosch Service Centre for details.

If you want to use an extension cable when operating your high pressure washer, only the following cable dimensions should be used:

- 1.5 mm<sup>2</sup> – max length 20 m
- 2.5 mm<sup>2</sup> – max length 50 m

Note: If an extension cable is used it must be earthed and connected through the plug to the earth cable of your supply network in accordance with prescribed safety regulations.

If in doubt contact a qualified electrician or the nearest Bosch Service Centre.

**WARNING! Inadequate extension cables can be dangerous. Extension cable, plug and socket must be of watertight construction and intended for outdoor use.**

Cable connections should be kept dry and off ground.

It is recommended for increased electrical safety to use a Residual Current Device (RCD) with a tripping current of not more than 30 mA. Always check your RCD every time you use it.

For products **not sold in GB**: WARNING: For safety, it is essential that the mains plug attached to the product is fitted to the power supply cable. The couplings of connection leads must be protected against splashes and the coupling sockets on the leads must be made of rubber or coated with rubber. Fixing means for the connection leads must be used.

If the supply cord is damaged, it must be replaced by a Bosch Service Centre.

Products sold in **GB** only: Your product is fitted with an approved 13 A (BS 1363/A) electric plug and is protected by a 13 A fuse (ASTA Approved to BS 1362).

If the fitted plug is not suitable for your socket outlets, it should be cut off and an appropriate plug fitted in its place.

The severed plug must be disposed of to avoid a possible shock hazard and should never be inserted into a 13 A socket elsewhere.

## Assembly

### Water supply



According to the applicable regulations, the appliance must never be used on the drinking water network without a system separator.

Use a separator as per EN 12729 Type BA.

### Water connection

**A** Screw inlet connector **8** onto machine water inlet connection **12**.

**A/B** Attach water supply hose (not supplied) to the mains water supply and machine.

### Connecting high pressure water supply hose/nozzle

**C** Securely screw high pressure hose **5** onto machine at connection **13**.

**D** Inserting the vario-jet/fan power lance **4** into the power gun **3**. Depress and turn the vario-jet /fan power lance 90° clockwise to lock in place.

## Adjustments and using different nozzles

### Vario-jet-fan power lance (red colour coded)

**E** Twist the front ring to adjust from a pencil to a fan jet and vice versa.

### Roto power lance (red colour coded)

**I** Turn the vario-jet /fan power lance **4** 90° anti-clockwise. Extract the vario-jet/fan power lance.

**J** Insert the roto-power lance **7** into the power gun **3**. Depress and turn the roto-power lance 90° clockwise to lock in place.

### Detergent nozzle and bottle

#### AQUATAK 110

**I** Turn the power lance 90° anti-clockwise. Extract the power lance.

**F** Insert the detergent-nozzle **6** into the power gun **3**. Depress and turn the detergent-nozzle 90° clockwise to lock in place.

#### AQUATAK 110 PLUS/115 PLUS

**G** To apply the detergent twist the rear ring as shown from high pressure mode to low pressure mode.

To adjust the spray pattern twist the front ring.

## Starting and Stopping

### Starting

Connect the product to the mains supply ensuring that the mains switch is in the (Ⓢ) position.

Open water tap.

**K** Press the safety lock **1** to release the trigger **2**. Fully press the trigger **2** until there is a constant flow of water to clear the air from the machine and water supply hose. Release trigger **2**. Press the trigger safety lock.

Press button (Ⓜ) on main switch **10**.

Point the power gun **3** downwards. Press the trigger safety lock to release the trigger **2**. Fully press the trigger **2**.

### Stopping

Release trigger **2**. Press the trigger safety lock. The power gun is now locked and can not be operated accidentally.

Press button (Ⓢ) on the main switch **10**.

Close water tap. Unplug the machine from the electric supply.

Press the trigger safety lock **1** to release the trigger **2**. Fully press the trigger **2** until there is no more water pressure in the machine. Release trigger **2**. Press the trigger safety lock **1**.

Disconnect water supply hose from machine and water supply.

## Advice using pressure washer

### General

Ensure that the machine is on level ground.



Do not overreach with the high pressure hose or move the pressure washer by pulling the hose, this could cause the machine to become unstable and fall over.

Do not kink or drive a motor vehicle over the high pressure hose. Do not expose the high pressure hose to sharp edges or corners.

Never use the roto nozzle to clean motor vehicles.

### Operating with Detergents

**Only use Bosch approved detergents. Unsuitable detergents may damage the unit and the object being cleaned.**

#### AQUATAK 110

Attach the detergent-nozzle to the spray gun.

Fill the detergent bottle with suitable detergent and screw the bottle back on the detergent-nozzle.

#### AQUATAK 110 PLUS/115 PLUS

**F** Fill the detergent tank **9** with detergent, dilute as recommend.

**G** To spray detergent move vario-jet-fan power lance to low pressure mode.

We recommend that you use detergent sparingly for the sake of the environment. Observe the recommended dilution on the detergent label.

By offering you an individualised range of cleaning and preserving agents, Bosch guarantees trouble-free operation of the unit.

### Recommended cleaning method

#### Step 1: Loosening dirt

Spray on detergent sparingly and allow to react for a short time.

#### Step 2: Removing dirt

Spray off the loosened dirt with the high-pressure spray using a jet fan.

**Note:** When cleaning a vertical surface spray off dirt/detergent from the bottom and work in a upwards direction. Rinse from the top and work downwards.

## Maintenance



**Stop, remove plug from the power supply and disconnect from water supply.**

**Note:** To ensure long and reliable service, carry out the following maintenance regularly.

Regularly check for obvious defects such as loose fixings, and worn or damaged components.

Check that covers and guards are undamaged and correctly fitted. Carry out necessary maintenance or repairs before using.

If the pressure washer should happen to fail despite the care taken in manufacture and testing, repair should be carried out by an authorised service agent for Bosch garden products.

For all correspondence and spare parts orders, always include the 10-digit part number from the nameplate of the machine!

## Cleaning/inspecting the strainer

**L** Expose the strainer **14** in the machine water inlet connection by removing the inlet connector **8**.

The strainer **14** can be easily removed with long nose pliers. Rinse and replace. If damaged replace.

Never use the pressure washer without the strainer or a damaged strainer.

## Transport

To move the machine use the top handle and roll the machine on the wheels.

To transport the unit up or down steps or over obstacles, it must be lifted by the top handle.

If the unit is to be stored or transported horizontally the detergent tank should be drained first.

## After use storage

Clean the exterior of the machine thoroughly using a soft brush or cloth. Do not use water, solvents or polishes. Remove all debris, especially from the ventilation slots.

Frost will damage a pressure washer that has not been completely emptied of water. The machine should be stored in a frost free room.

Do not place other objects on top of the machine.

 Ensure cables are not trapped when storing.  
**Do not kink high pressure hose.**

## Fault Finding

The following table gives checks and actions that you can perform if your machine does not operate correctly. If these do not identify/remedy the problem, contact your service agent.

**Warning: Switch off and remove plug from mains before investigating fault.**

Symptom	Possible Cause	Remedy
Motor refuses to start	Plug not connected Mains socket faulty Fuse faulty/blown Extension cable damaged Motor protector has activated Frozen	Connect plug Use another socket Replace fuse Try without extension cable Allow to cool for 5 minutes Wait for pump/water supply hose/ accessory to thaw
Motor stops	Fuse faulty/blown Wrong mains voltage Motor protector has activated	Replace fuse Check that mains voltage corresponds to specifications on the model tag Allow to cool for 5 minutes
Fuses blow	Fuses incorrectly rated	Change to a mains supply higher than the pressure washer amp consump- tion
Excessive working pressure	Nozzle partly blocked	Clean nozzle
Pressure pulsating	Air in the inlet water supply hose/pump  Inadequate water supply  Water strainer blocked Water supply hoses squeezed  High pressure hose too long	Allow pressure washer to run with open spray handle and nozzle at low pressure until regular working pres- sure is obtained.  Check that the water supply corre- sponds to specifications. The mini- mum specification for the water supply hose is 1/2" or 13 mm diameter.  Clean water strainer  Straighten out kinked water supply hoses  Dismount high pressure extension hose. Retry (extension hose max. 7 m)

Pressure too low, but steady Note: Several types of accessory will normally deliver a lower pressure	Nozzle worn Start/stop valve worn	Change the nozzle Activate trigger five time in quick succession
Motor starts up but no working pressure	No water supply Water strainer clogged up Nozzle clogged up	Connect water supply Clean the water strainer Clean nozzle
The pressure washer starts irregularly by itself	Pump/power gun leaky	Contact your Bosch Service Centre
Water leaks from machine	Leaking pump	6 drops per minute are permissible. In case of more serious leakage, you should contact your Bosch Service Centre.

### Environmental Protection

Chemicals dangerous to the environment must not be allowed to enter the ground, ground water or ponds, streams, etc.

For the use of cleaning agents, observe the instructions on the package and the prescribed concentration exactly.

For the cleaning of motor vehicles the local regulations should be observed: Do not allow oil sprayed off to enter into the ground water. Recycle raw materials instead of waste disposal.

### Disposal

Product, accessories and packaging should be sorted for environmental-friendly recycling.

#### Only for EC countries:



Do not dispose of the product into household waste!  
According to the European Directive 2002/96/EC on waste electrical and electronic equipment and its incorporation into national law, products that are no longer suitable for use must be separately collected and sent for recovery in an environmentally-friendly manner.

### Service

**Exploded views and information on spare parts can be found under:**  
[www.bosch-pt.com](http://www.bosch-pt.com)

#### Great Britain

Robert Bosch Ltd. (B.S.C.)  
P.O. Box 98  
Broadwater Park  
North Orbital Road  
Denham-Uxbridge  
Middlesex UB 9 5HJ

☎ Service..... +44 (0) 18 95 / 83 87 82  
Fax Service..... +44 (0) 18 95 / 83 87 89  
☎ Advice line..... +44 (0) 18 95 / 83 87 91  
Fax Advice..... +44 (0) 18 95 / 83 87 93

#### Ireland

Beaver Distribution Ltd.  
Greenhills Road  
Tallaght-Dublin 24

☎ Service..... +353 (0)1 / 45 15 211  
Fax..... +353 (0)1 / 45 17 127

#### Malaysia

Robert Bosch (SEA.) Pte. Ltd.  
No. 8a, Jalan 13/6  
Selangor Darul Ehsan  
Petaling Jaya 46200  
Malaysia

☎..... +60 3 79 58 30 00  
Fax (EW Dept.) ..... +60 3 79 58 38 38  
[www.bosch.com.sg](http://www.bosch.com.sg)

**Australia**

Robert Bosch Australia Ltd.  
RBAU/SPT2  
1555 Centre Road  
P.O. Box 66 Clayton  
3168 Clayton/Victoria

☎ ..... +61 (0)1 / 800 804 777

Fax ..... +61 (0)1 / 800 819 520

www.bosch.com.au

E-Mail: CustomerSupportSPT@au.bosch.com

**New Zealand**

Robert Bosch Limited  
14-16 Constellation Drive  
Mairangi Bay  
Auckland  
New Zealand

☎ ..... +64 (0)9 / 47 86 158

Fax ..... +64 (0)9 / 47 82 914

**Noise/Vibration Information**

Measured sound values determined according to 2000/14/EC (1.60 m height, 1 m distance away).

Typically the A-weighted noise levels of the product are: Sound pressure level 79 dB(A); sound power level 89 dB(A). Uncertainty K = 3 dB.

Vibration total values (triax vector sum) determined according to EN 60335: Vibration emission value  $a_h = 2.6 \text{ m/s}^2$ , Uncertainty K =  $0.8 \text{ m/s}^2$ .

**Declaration of Conformity**

We declare under our sole responsibility that the product described under "Technical data" is in conformity with the following standards or standardization documents: EN 60335 according to the provisions of the directives 2011/65/EU, 2004/108/EC, 2006/42/EC, 2000/14/EC.

2000/14/EC: Guaranteed sound power level 89 dB(A). Conformity assessment procedure according to Annex V.

Equipment category: 27

Technical file (2006/42/EG) at:

Bosch Lawn and Garden Ltd., PT-LG/EAE,  
Stowmarket, Suffolk IP14 1EY, England

Dr. Egbert Schneider  
Senior Vice President  
Engineering

Helmut Heinzelmann  
Head of Product  
Certification

*Dr. Egbert Schneider* i.V. *Helmut Heinzelmann*

Robert Bosch GmbH, Power Tools Division  
D-70745 Leinfelden-Echterdingen  
23.03.2012

**Subject to change without notice**