



# BOSCH

Installation and Operation Instructions

## INDOOR MODEL

### C 950 / C 1050 ES (Pro TL 175C/199C)

C 950 / C 1050 ES (Pro TL 175C/199C) - Natural Gas

C 950 / C 1050 ES (Pro TL 175C/199C) - Liquefied Petroleum (LP) Gas

<Review>

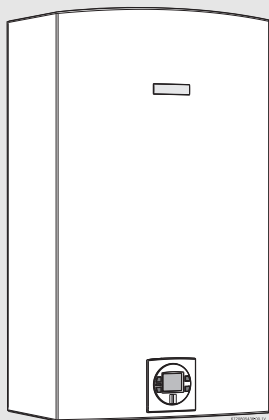

**⚠ WARNING!**

Improper installation, adjustment, alteration, service or maintenance can cause injury or property damage. Refer to this manual. For assistance or additional information consult a qualified installer, service agency or the gas supplier.

**NOTICE**

Upon completion of the installation, these instructions should be handed to the user of the appliance for future reference.

**⚠ WARNING: If the information in these instructions is not followed exactly, a fire or explosion may result causing property damage, personal injury or death.**

- Do not store or use gasoline or other flammable vapors and liquids in the vicinity of this or any other appliance.
- WHAT TO DO IF YOU SMELL GAS
  - Do not try to light any appliance.
  - Do not touch any electrical switch; do not use any phone in your building.
  - Immediately call your gas supplier from a neighbor's phone. Follow the gas supplier's instructions.
  - If you cannot reach your gas supplier, call the fire department.
- Installation and service must be performed by a qualified installer, service agency or the gas supplier.

6720816815-38.2V



# Greentherm™



## Table of contents

<b>1 Key to symbols and safety instructions</b> .....	<b>3</b>	6.5 Use of optional remote control accessory (part no. 7709003213) .....	54
1.1 Key to symbols .....	3	6.6 Operation .....	55
1.2 Safety instructions .....	3	6.7 Reset button .....	55
<b>2 FCC rules</b> .....	<b>8</b>	6.8 Program button .....	55
<b>3 Appliance details</b> .....	<b>9</b>	6.9 Locked condition .....	55
3.1 Features .....	9	<b>7 Maintenance and service</b> .....	<b>56</b>
3.2 Specifications (Technical data) .....	10	7.1 Annual maintenance .....	56
3.3 Unpacking the heater .....	11	7.2 Winterizing for seasonal use .....	57
3.4 General rules to follow for safe operation .....	12	7.3 Mineral scale build-up .....	57
3.5 Dimensions and minimum installation clearances .....	14	7.5 Adjusting CO2 .....	59
<b>4 Installation instructions</b> .....	<b>15</b>	7.6 Program values .....	61
4.1 Specialized tools .....	15	7.7 Control board diagnostics .....	62
4.2 Introduction .....	15	<b>8 Troubleshooting</b> .....	<b>63</b>
4.3 Venting .....	15	8.1 Introduction .....	63
4.4 Combustion air requirements .....	38	8.2 Burner does not ignite when hot water is turned ON .....	63
4.5 Proper location for installing your heater .....	39	8.3 Water is too hot .....	64
4.6 Heater placement and clearances .....	39	8.4 Water is not hot enough .....	64
4.7 Hanging appliance on the wall .....	39	8.5 Low water flow/pressure .....	64
4.8 Gas piping & connections .....	40	8.6 Hot water temperature fluctuates at tap .....	64
4.8.1 Gas Line Sizing Tables for NATURAL GAS .....	42	8.7 Noisy burner/heater during operation .....	65
4.8.2 Gas Line Sizing Tables for LP GAS .....	43	<b>9 Problem solving</b> .....	<b>66</b>
4.9 Water connections .....	44	9.1 Error code diagnostics .....	66
4.10 Water quality .....	44	<b>10 Electrical diagram</b> .....	<b>70</b>
4.11 Filling the condensate trap .....	45	<b>11 Sensor resistance charts</b> .....	<b>71</b>
4.12 Domestic hot water recirculation .....	46	<b>12 Functional scheme</b> .....	<b>73</b>
4.13 Space heating applications .....	47	<b>13 Interior components diagram and parts list</b> .....	<b>74</b>
4.14 Measuring gas pressure .....	49	<b>14 Protecting the environment</b> .....	<b>86</b>
<b>5 Electrical connections</b> .....	<b>51</b>	<b>15 Installer Checklist to be completed by installer upon installation</b> .....	<b>86</b>
5.1 Electrical power supply .....	51		
5.2 Position of the fuses in control unit .....	51		
<b>6 Operation instructions</b> .....	<b>52</b>		
6.1 Description LCD Display .....	52		
6.2 For your safety read before operating your water heater .....	53		
6.3 Power .....	53		
6.4 Temperature selection .....	53		

Review

# 1 Key to symbols and safety instructions

## 1.1 Key to symbols

### Warnings

In warnings, signal words at the beginning of a warning are used to indicate the type and seriousness of the ensuing risk if measures for minimising danger are not taken.

The following signal words are defined and can be used in this document:

 **DANGER:**  
**DANGER** indicates a hazardous situation which, if not avoided, will result in death or serious injury.

 **WARNING:**  
**WARNING** indicates a hazardous situation which, if not avoided, could result in death or serious injury.

 **CAUTION:**  
**CAUTION** indicates a hazardous situation which, if not avoided, could result in minor or moderate injury.

**NOTICE:**  
**NOTICE** is used to address practices not related to personal injury.

### Important information

 The info symbol indicates important information where there is no risk to people or property.

### Additional symbols

Symbol	Meaning
▶	a step in an action sequence
→	a reference to a related part in the document
•	a list entry
–	a list entry (second level)

Table 1

## 1.2 Safety instructions

### **WARNING:**

#### **Before installation,**

- ▶ Read all instructions before installing. Perform the steps in the indicated sequence.
- ▶ Have the water heater inspected by a trained service technician at least once every year.
- ▶ Failure to comply with these instructions can result in severe, possibly fatal, personal injury as well as damage to property and equipment.

### **DANGER:**

#### **Installation and servicing.**

#### **Risk of fire when soldering and brazing!**

- ▶ Take appropriate protective measures when soldering and brazing around combustible and flammable material.
- ▶ Ensure that only a licensed contractor installs or services the water heater.
- ▶ On hot components use only material with adequate temperature stability.

### **WARNING:**

#### **Installation and commissioning.**

- ▶ Do not install this device in rooms with a high moisture level (e.g. bathrooms, saunas).

**<Review>**

### **⚠ WARNING:**

- ▶ To ensure that the water heater functions properly, follow these installation and maintenance instructions.
- ▶ Never close the blow-off line of the pressure safety valve. For safety reasons, water may escape during heating.

### **⚠ DANGER:**

#### **Risk of explosion!**

##### **If you smell gas.**

- ▶ Turn off the gas shut-off valve.
- ▶ Open windows and doors.
- ▶ Do not try to light the appliance.
- ▶ Do not touch any electrical switch, telephone, and do not use outlets.
- ▶ Extinguish all open flames. Do not smoke! Do not use lighters!
- ▶ Warn all occupants of the building. Do not ring doorbells!
- ▶ If you can hear gas leaking, leave the building immediately.
- ▶ Prevent others from entering the building and notify the police and fire department from outside the building.
- ▶ From outside the building, call the gas utility company and a trained and certified installer.

### **⚠ DANGER:**

#### **If you smell flue gas,**

- ▶ Switch off the appliance.

- ▶ Open windows and doors.
- ▶ Inform the certified installer who installed the appliance.

### **⚠ DANGER:**

#### **Risk of poisoning!**

#### **Insufficient ventilation may cause toxic flue gas to escape.**

- ▶ Never close off or reduce the size of the air intake and outlet openings.
- ▶ The appliance must not be operated until any obstructions have been removed.
- ▶ Inform the customer of the problem and the associated dangers.

### **⚠ DANGER:**

#### **Danger from escaping flue gases.**

- ▶ Ensure all vent pipes and chimneys are not damaged or blocked.
- ▶ Connect only one appliance to each vent system or chimney liner.
- ▶ The venting system piping must not feed into another air extraction duct.
- ▶ Do not route the flue system piping through or inside another air extraction duct.

### **⚠ DANGER:**

#### **Danger of explosion of flammable gases.**

- ▶ Work on gas components may only be carried out by a trained and certified installer.

**<Review>**

- ▶ Installation, gas and flue connection, initial commissioning, electrical connections and annual maintenance must only be carried out by a trained and certified installer.

**⚠ CAUTION:****Combustion air.**

- ▶ Keep the combustion air free of corrosive substances (halogenated hydrocarbons that contain chlorine or fluorine compounds).

**⚠ WARNING:****Never shut off safety valves!**

- ▶ Water may escape from the safety valve at any time when the water is being heated.

**⚠ WARNING:****Inspection/maintenance**

- ▶ Servicing and repairs may only be carried out by a trained and certified installer.
- ▶ Immediately correct all faults to prevent system damage.
- ▶ Use only Bosch spare parts!

**⚠ CAUTION:****Instruct the customer.**

- ▶ Explain to the customer how the appliance works and how to operate it.
- ▶ Inform the customer that he/she must not carry out any alterations or repairs.

**⚠ DANGER:****Risk of electric shock!**

- ▶ Ensure that only an authorized contractor performs electrical work.
- ▶ Before performing electrical work, disconnect the power and secure the unit against unintentional reconnection.
- ▶ Ensure the system has been disconnected from the power supply.

**⚠ DANGER:****Risk of scalding at the hot water fixture!**

- ▶ When the water heater is in operation, temperatures in excess of 122 °F (50 °C) can occur. To limit the temperature at the tap, install a thermostatic DHW mixing valve.
- ▶ Water heated for washing the laundry, dishes and for other cleaning purposes can cause scalding and permanent injuries.
- ▶ Children, disable and elderly are at highest risk of being scalded. Never leave such individuals in the tub or shower unattended under any circumstances. Children must not be allowed to operate hot water faucets themselves.

- ▶ If the building has occupants in the above groups who operate hot water faucets, or state laws / local ordinances stipulate specific water temperatures, take the following precautions:
  - Use the lowest possible temperature setting.
  - To prevent scalding, install a tempering device, such as an automatic mixing valve, at hot water tap or water heater. Select and install the automatic mixing valve in accordance with the valve manufacturer's recommendations and instructions.
- ▶ Water exiting from drain valves can be extremely hot. To avoid injuries:
  - Check that all connections are tight.
  - Direct exiting water away from people.
- ▶ Measures must be taken to protect against excessive temperature and pressure! Installation of a T&P safety valve is required.

### **⚠ WARNING:**

#### **Electrical safety.**

To protect against corrosion and ensure compliance with the rules for electrical safety, observe the following points:

- ▶ Use metal fittings for potable water heating systems with plastic piping.
- ▶ Use only original accessories from the manufacturer.

- ▶ When installation of the water heater is complete, inspect and confirm proper ground conductor.

### **⚠ CAUTION:**

#### **Maintenance**

- ▶ Inspect and maintain the water heater on a yearly basis. Service as needed.
- ▶ See chapter 7.1.
- ▶ Use only genuine spare parts.

### **⚠ WARNING:**

#### **Flooding**

- ▶ After a flood, do not use the appliance if any part has been submerged. Damage to appliances that have been submerged can be quite severe and pose numerous safety risks.
- ▶ Every appliance that has been submerged must be replaced.

### **⚠ WARNING:**

#### **Risk of explosion!**

#### **For your safety**

- ▶ Do not store or use gasoline or other flammable, combustible or corrosive vapors and liquids in the vicinity of this or any other appliance.

**DANGER:****Fatal accidents!**

Carbon monoxide poisoning.

- ▶ Carefully plan where you install the heater. Correct combustion air supply and flue pipe installation are very important. If a gas appliance is not installed correctly, fatal accidents can result such as carbon monoxide poisoning or fire.

**DANGER:**

Carbon monoxide poisoning.

- ▶ Exhaust gas must be vented to outside using approved vent material. See table 5, page 16 (In Canada use only ULCS636 approved material). Vent and combustion air connector piping must be sealed gas-tight to prevent flue gas spillage, carbon monoxide emissions and risk of fire, resulting in severe personal injury or death. Approved vent terminations must be used when penetrating to the outside.

**DANGER:****Electric shock!**

- ▶ Field wiring connections and electrical grounding must comply with local codes, or in the absence of local codes, with the latest edition of the National Electric Code, ANSI/NFPA 70, or in Canada, all electrical wiring must comply with the local codes and the Canadian Electrical Code, CSA C22.1 Part 1.

**DANGER:****Electric shock!**

Shock hazard: line voltage is present.

- ▶ Before servicing the water heater, unplug power supply cord from outlet. Failure to do so could result in severe personal injury or death.

**WARNING:****Damage to the appliance from over pressure.**

- ▶ The heater must be disconnected from the gas supply piping system during any pressure testing of that system at test pressures equal to or more than 0.5 psi.

**NOTICE:**

- ▶ The appliance should be located in an area where leakage of the heater or connections will not result in damage to the area adjacent to the appliance or to lower floors of the structure. When such locations cannot be avoided, it is recommended that a suitable drain pan, adequately drained, be installed under the appliance. The pan must not restrict combustion air flow.

**WARNING:**

- ▶ The maximum inlet gas pressure must not exceed the value specified by the manufacturer and the minimum value listed is for the purpose of input adjustment.

**NOTICE:**

- ▶ If a water heater is installed in a closed water supply system, such as one having a backflow preventer in the cold water supply line, means shall be provided to control thermal expansion. Contact the water supplier or local plumbing inspector on how to control this situation.

**WARNING:****Fire danger!**

- ▶ Keep appliance area clear and free from combustible materials, gasoline and other flammable vapors and liquids.

**NOTICE:**

- ▶ Do not obstruct the flow of combustion and ventilation air.

**NOTICE:****Appliance malfunction!**

- ▶ If power is lost while appliance is operating. Turn off both water and power for 15 seconds to reset device.



**WARNING:**

**Risk of scalding and property damage.**

- ▶ Precautions must be taken prior to manually operating the relief valve to avoid contact with hot water discharged from the relief valve and to prevent water damage.

**NOTICE:**

**Appliance damage!**

- ▶ Label all wires prior to disconnection when servicing controls. Wiring errors can result in improper and dangerous operation. Verify proper operation after servicing.



**WARNING:**

**System damage!**

- ▶ If a relief valve discharges periodically, this may be due to thermal expansion in a closed water supply system. Contact the water supplier or local plumbing inspector on how to correct this situation. Do not plug the relief valve.



**WARNING:**

**Property damage!**

- ▶ If the water heater is used in a space heating application, all piping and components connected to the water heater must be suitable for use with potable water.



**WARNING:**

**Personal Injury from toxic chemicals.**

- ▶ Toxic chemicals, such as those used for boiler treatment, shall not be introduced into the potable water used for space heating.



**WARNING:**

**Personal Injury from toxic chemicals.**

- ▶ A water heater which will be used to supply potable water shall not be connected to any heating system or component(s) previously used with a nonpotable water heating appliance.

**2 FCC rules**

FCC: This device complies with Part 15 of the FCC rules.

Operation is subject to the following two conditions: (1) This device may not cause harmful interference, and (2) this device must accept any interference received, including interference that may cause undesired operation.

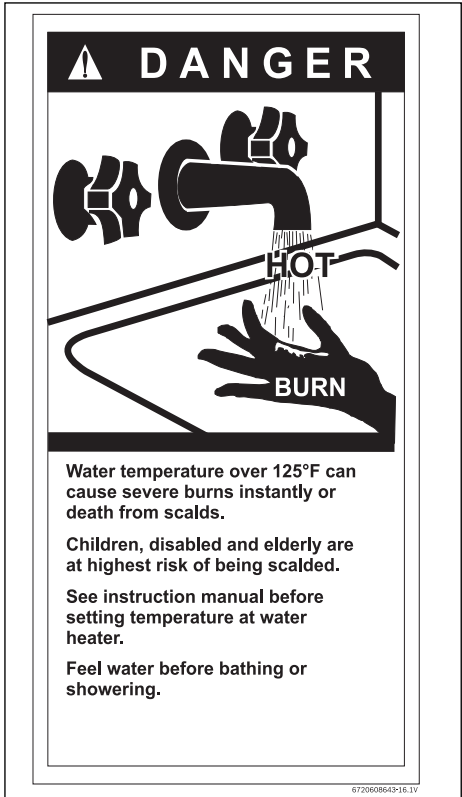

**<Review>**

Fig. 1

The chart below shows the relationship between water temperature and time until there is a risk of scalding. It can be used as the basis for determining the safest water temperature for your application.

Temperature	Time to severe scalding <sup>1)</sup>
120 °F (48 °C)	longer than 5 minutes
125 °F (51 °C)	1.5 to 2 minutes
130 °F (54 °C)	approx. 30 seconds
135 °F (57 °C)	approx. 10 seconds
140 °F (60 °C)	less than 5 seconds

Temperature	Time to severe scalding <sup>1)</sup>
145 °F (62 °C)	less than 3 seconds
150 °F (65 °C)	approx. 1.5 seconds
155 °F (68 °C)	approx. 1 second

- 1) Source: Moritz, A.R. and Henriques, F.C., Jr. (1947). Studies of thermal injury. II. The relative importance of time and surface temperature in the causation of cutaneous burns, Am J of Pathol, 23, 695-720.

Table 2 *Approximate time-temperature relationship until there is a risk of scalding*

**WARNING:**

This product can expose you to chemicals including lead, which is known to the State of California to cause cancer and birth defects or other reproductive harm. For more information go to [www.P65Warnings.ca.gov](http://www.P65Warnings.ca.gov).

BOSCH water heater complies with the State of California Lead Law (AB1953).

## 3 Appliance details

### 3.1 Features

#### Parts

- Key Pad interface control.
- High power pre-mix compact burner with low NOx emissions.
- Modulating Gas Valve with constant gas:air ratio control.
- Modulating water valve for improved comfort and temperature control.

#### High quality materials for long working life

- Copper heat exchanger.
- High efficiency Ceramat Burner.
- Compact space saver: mounts on a wall with a supplied bracket.

#### Features

- Easily removable one-piece cover.
- On/Off and Temperature control buttons.
- Reset button.
- Program button (Selectable temperature default).
- Failure codes for easy diagnostics and repair.
- Real-time diagnostics for troubleshooting/informational purposes.
- Built in freeze prevention.

Note: The freeze prevention kit is designed to provide protection for the water heater down to **approximately 5°F for short term conditions only**. It will not protect the appliance in areas where the temperature is routinely expected to be below freezing.

- The freeze prevention kit will not protect plumbing outside the appliance from freezing. Precautions should be taken.

#### Accessories (Bosch part #)

- Concentric termination kit 3" / 5" PVC (196006)
- Concentric vent kit 80/125 PP (7738003210)
- Concentric Up and Out kit (7 738 003 210)
- Neutralizer Kit (7738001483)
- Isolation Valve Kit (7738003449)
- Optional wireless remote control to operate with the appliance (7709003213)
- Cascading kit (7 709 003 962)
- Outdoor kit (7709003913)
- Concentric termination kit 3"/6" PVC (196016)
- Exhaust/Intake bird screen (L2594)
- Condensate drain tee (196061) [included with Concentric termination kits]
- Pipe Cover (PTPCES)
- High temperature kit (7736500074)
- Recess box kit (7736500043)
- Pressure relief valve (7 738 001 152)



BOSCH is constantly improving its products, therefore specifications are subject to change without prior notice.

### 3.2 Specifications (Technical data)

Approved in US/Canada

Technical characteristics	Units	C 950 ES (Pro TL 175C)	C 1050 ES (Pro TL 199C)
<b>Capacity</b>			
Maximum flow rate at a 25 °F (13.9 °C) rise	GPM (l/min)	13.1 (49.7)	14.9 (56.5)
Maximum flow rate at a 35 °F (19.4 °C) rise	GPM (l/min)	9.4 (35.5)	10.7 (40.4)
Maximum flow rate at a 45 °F (25 °C) rise	GPM (l/min)	7.3 (27.6)	8.3 (31.4)
Maximum flow rate at a 55 °F (30.6 °C) rise	GPM (l/min)	6.0 (22.6)	6.8 (25.7)
Maximum flow rate at a 75 °F (41.7 °C) rise	GPM (l/min)	4.4 (16.5)	5.0 (18.8)
Maximum flow rate at a 90 °F (50 °C) rise	GPM (l/min)	3.6 (13.8)	4.2 (15.7)
Maximum output	BTU/hr (kW)	160,500 (47)	184,500 (54)
Maximum input	BTU/hr (kW)	175,000 (51.2)	199,000 (58.3)
Thermal efficiency (Efficiency in %)	%	> 94%	
Minimum Input	BTU/hr (kW)	19,900 (5.8)	
<b>Temperature Control</b>			
Selection range	°F (°C)	100 - 140 (38 - 60)	
Default temperature	°F (°C)	122 (50)	
Stability	°F (°C)	± 2 (± 1)	
<b>Gas Requirement</b>			
Gas connection	inches	¾"	
Peak load inlet gas pressure <sup>1)</sup>			
Propane	water column	8" - 13"	
Natural Gas	water column	3.5" - 10.5"	
<b>Water</b>			
Hot water connection	inches	¾"	
Cold water connection	inches	¾"	
Minimum water flow <sup>2)</sup>	GPM (l/min)	0.5 (1.9)	
Minimum recommended water pressure	PSI (bar)	30 (2.07)	
Minimum well pressure	PSI	40	
Water valve material		Polymer (PPS) (Polypropylene Sulfide)	
Connections:		Bottom of heater	
<b>Combustion</b>			
CO level	ppm	≤ 290 (measured)	
CO <sub>2</sub> level (set from factory)	%	see table 48	
<b>Dimensions</b>			
Depth	inches (mm)	11 ¼ (286)	
Width	inches (mm)	17 7/8 (452)	
Height	inches (mm)	30½ (775)	
Weight	pounds (kg)	74 (33.5)	
Nominal	VAC	120	

**<Review>**

Technical characteristics	Units	C 950 ES (Pro TL 175C)	C 1050 ES (Pro TL 199C)
Frequency	Hz		60
<b>Amperage</b>			
Idle	mA		40
Operation	A		≤ 2.5
Noise	db (A)		45 - 65
Water protection <sup>3)</sup>	IP		X4D

- 1) To measure Gas Pressure, see Measuring Gas Pressure, chapter 4.14, page 49.
- 2) Activation varies with inlet water temperatures from 0.5 - 1.6 gallon/minute (1.9 - 6.1 l/m).
- 3) Protection against water drops.

Table 3

**i** If appliance is installed at elevations above 2000ft, refer to chapter 4.3.8 Fan speed adjustment.

**Safety devices**

- Flame failure device (ionization flame rod sensor)
- Overheat prevention (temperature limiter)
- Inlet temperature sensor
- Outlet temperature sensor
- Back flow temperature sensor
- Exhaust gas temperature sensor

**3.3.1 The box includes**

- Greentherm water heater
- Bracket for wall hanging the heater
- Exhaust vent adaptor (with 4 screws and gasket provided)
- Combustion air inlet adaptor (with 3 screws and gasket provided)
- Installation manual (manual can be downloaded at [www.boschheatingandcooling.com](http://www.boschheatingandcooling.com).)
- Product registration card
- Energy Guide label

Please complete and return the enclosed product registration card.

**The Greentherm is not approved or designed for:**

- **Manufactured (mobile) homes, boats or any mobile installation. (Modular homes are acceptable for installation).**
- **Use above 8000 ft A.S.L. altitude (see page 33).**
- **Outdoor installation without installation of Outdoor kit (BTOK): Outdoor installations in areas where annual minimum temperatures are below 15 °F.**
- **Applications where inlet water temperature is higher than 140 °F (60 °C). In these applications a 3 way valve or thermostatic mixing valve must be installed to prevent inlet water temperatures > than 140 °F (60 °C).**

**3.3 Unpacking the heater**

**Before installing the unit, be certain you have the correct heater for your type of Gas - Propane or Natural Gas.**

Identification labels are found on the shipping box, and on the rating plate which is located on the right side panel of the cover.

MODEL # / N° DE MODELE [ ] ORDER # / N° DE COMMANDE [ ] FD # / N° DE SERIE [ ]

AUTOMATIC INDEPENDENT WATER HEATER / CHAUFFE EAU INDEPENDANT AUTOMATIQUE  
 GAS WATER HEATER / CHAUFFE EAU  
 HYDROSTATIC PRESSURE 300 psi MAX. HYDROSTATIQUE DEBRIEN A PRESURE 150 psi.

FOR OPERATION AT OUTLET WATER TEMPERATURE OF 140° F.  
 POUR LE FONCTIONNEMENT A UNE TEMPERATURE DE 140° F. A LA DECHARGE.  
 SOUS UNE PRESSION HYDROSTATIQUE MAX. 300 psi. PRESSION HYDROSTATIQUE DE FONCTIONNEMENT 150 psi.

0 - 2000 FT. 0 - 610 m STANDARD ALT. ALTITUDE NORMALE	RATINGS AT ALTITUDE / EVALUATION A DIFFERENTE ALTITUDE	800 - 4500 FT. 80 - 1370 m HIGH ALTITUDE HAUTE ALTITUDE
MAX. INPUT BTU/H	CONCOMANTION MAX. BTU/H	
MIN. INPUT BTU/H	CONCOMANTION MIN. BTU/H	
REC. RATINGS, U.S. GAL/MIN.	RECOMMANDE U.S. GAL/MIN.	
ORIFICE SIZE	TAILLE DES ORIFICES	
INLET PRESS., IN W.C.	PRESION D'ENTREE EN Po	
VENT. DIAM., INCHES	DIAMETRE DU CONDUIT DE CHEMINÉE	
MIN. GAS SUPPLY PRESS., IN W.C.	LA PRESION MINIMUM DU GAZ EN Po	

FOR PURPOSE OF RATE ADJUSTMENT POUR RAYSON D'AJUSTEMENT

ADJUSTABLE FLOW WATER HEATERS  
 TYPE OF GAS [ ] MAX. GAS PRESS. 3.7kPa 11/2 PSIG  
 TYPE OF GAS [ ] LA PRES. DU GAZ FOURNI EST DE 3.7 kPa 11/2 psi

8720608030-15-TV

Fig. 2 Rating plate

- [1] Serial number
- [2] Type of gas

Review

### 3.3.2 Remove front cover

- ▶ Loosen the two Phillips head screws located on bottom rear of cover.

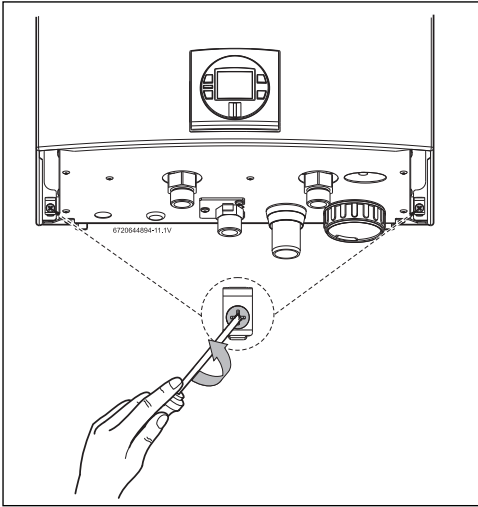

Fig. 3 Loosen the two screws

- ▶ Lift front cover panel upward and remove.

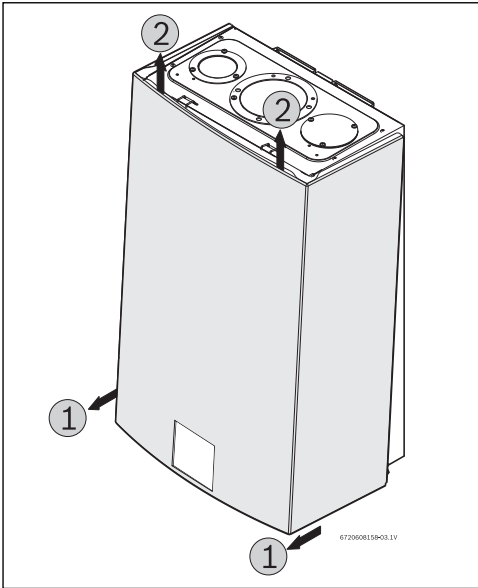

Fig. 4 Remove the front cover

### 3.3.3 Remove combustion cover (service only)

- ▶ Open the four clips and remove the combustion cover.

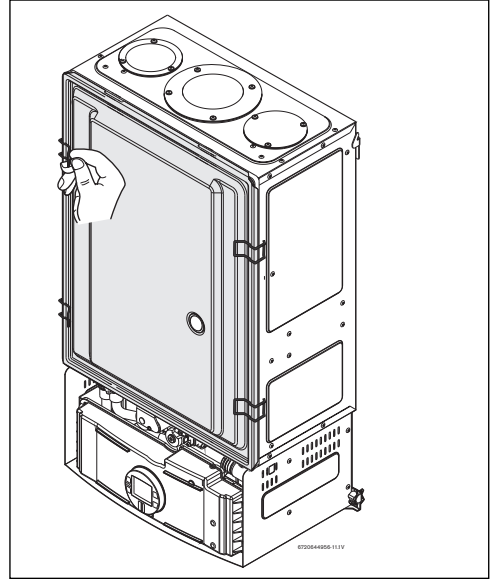

Fig. 5 Remove the combustion cover

### 3.4 General rules to follow for safe operation

- **1.** You must follow these instructions when you install your heater. In the United States: The installation must conform with local codes or, in the absence of local codes, the National Fuel Gas Code ANSI Z223.1/NFPA 54. In Canada: The Installation must conform with CSA B149.(1,2) INSTALLATION CODES and /or local installation codes.
- **2.** Carefully plan where you install the heater. Correct combustion air supply and vent pipe installation are very important. If not installed correctly, fatal accidents can occur, such as carbon monoxide poisoning or fire.
- **3.** When the unit is installed indoors and ROOM SEALED (twin pipe) it is permitted to be located in bathrooms, bedrooms and occupied rooms that are normally kept closed. See chapter 4.3 (page 15). If the unit will be installed indoors and use indoor combustion air, the place where you install the heater must have enough ventilation.  
**The National Fuel Gas Codes do not allow UNSEALED gas fired water heater installations in bathrooms, bedrooms or any occupied rooms normally kept closed.** See chapter 4.4 (page 38).
- **4.** You must correctly vent your heater. See chapter 4.3 (page 15) on VENTING.

**<Review>**

- **5.** The appliance and its gas connection must be leak tested before placing the appliance in operation. The appliance must be isolated from the gas supply piping system by closing its individual manual gas shutoff valve (not supplied with heater) during any pressure testing at pressures in excess of ½ Psig (3.5 kPa).
- **6.** Keep water heater area clear and free from combustibles and flammable liquids. Do not locate the heater over any material which might burn.
- **7. Correct gas pressure** is critical for the proper operation of this heater. Gas piping must be sized to provide the required pressure at the maximum output of the heater, while all the other gas appliances are in operation. Check with your local gas supplier, and see the section on connecting the gas supply. See chapter 4.8 (page 40).
- **8.** Should overheating occur or the gas supply fail to shut off, turn off the gas supply at the manual gas shut off valve, on the gas line. Note: manual gas shutoff valve is not supplied with the heater but must be field installed.
- **9.** Do not use this appliance if any part has been underwater. Immediately call a qualified service technician to inspect the appliance and to replace any part of the control system and any gas control which has been underwater.
- **10.** Failure to install heater correctly may lead to unsafe operation and void the warranty.

**3.5 Dimensions and minimum installation clearances**

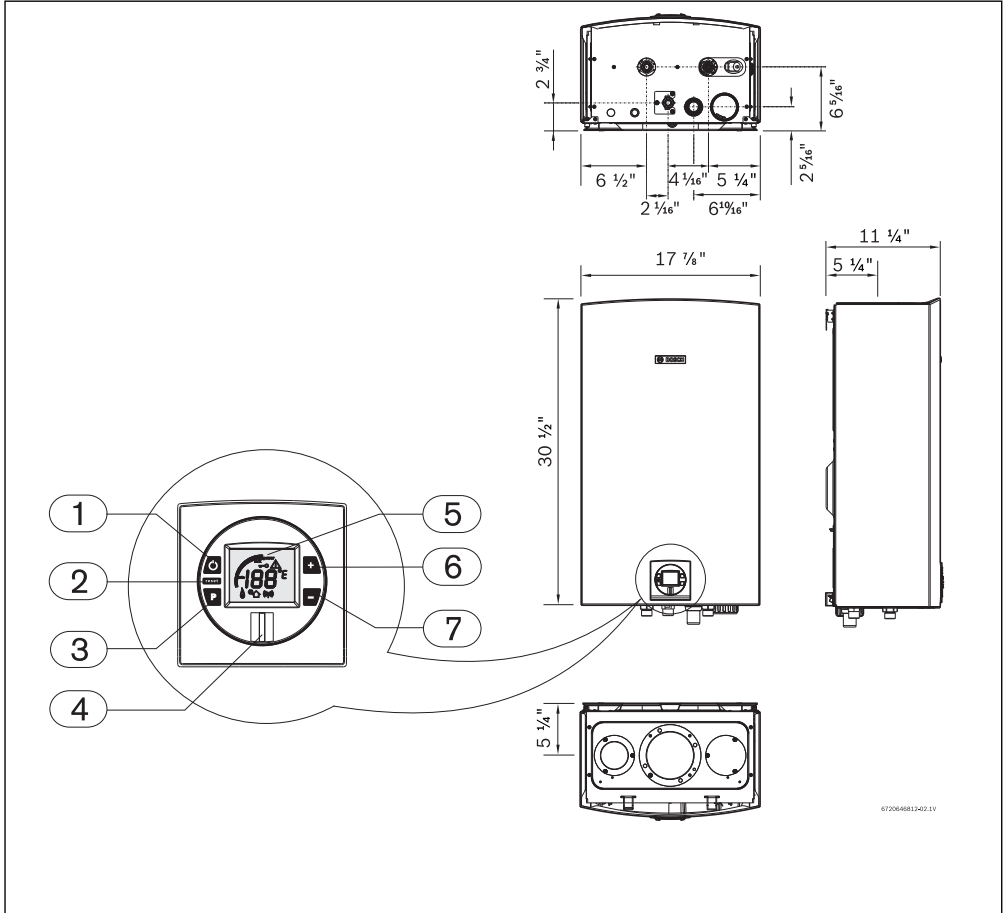

Fig. 6 Dimensions

- [1] On/Off button
- [2] Reset button
- [3] Program key
- [4] Power ON or stand-by LED
- [5] LCD display
- [6] Up button
- [7] Down button

**<Review>**

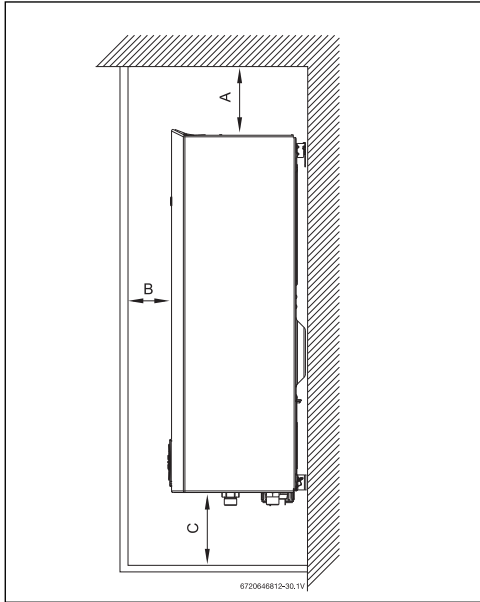

Fig. 7 Side view



For servicing access, a 2ft clearance is recommended to the front cover.

	Greentherm (Pro TL 175/199)
TOP (A)	12"
FRONT (B)	1"
BACK	0"
SIDES	1"
FLOOR (C)	12"

Table 4 Recommended minimum clearances

## 4 Installation instructions

### 4.1 Specialized tools

The following specialized tools may be required for installation:

- Manometer
- Multi-meter
- Combustion Gas Analyzer

### 4.2 Introduction

**Please follow these instructions. Failure to follow instructions may result in:**

- ▶ Damage or injury.
- ▶ Improper operation.
- ▶ Loss of warranty.



**DANGER:**

- ▶ The water heater must be installed by a qualified installer in accordance with these instructions. If improperly installed, a hazardous condition such as explosion or carbon monoxide poisoning could result. Bosch Thermotechnology Corp. is not responsible for improperly installed appliances.



Common installation practice is to first determine the venting/combustion air point of termination, then design the piping layout back to the heater.

### 4.3 Venting



**DANGER:**

- ▶ Do not reduce the exhaust or combustion air vent pipe sizes.
- ▶ Do not common vent with any other vented appliance or stove.
- ▶ Do not use Type-B vent as the actual exhaust vent system for the appliance.



**DANGER:**

#### **Flue gas poisoning!**

- ▶ Failure to vent the exhaust gases to the outside (see table 5 for proper material) may result in dangerous flue gases filling the structure in which it is installed.

**<Review >**

**NOTICE:**

- ▶ In areas where outside temperatures routinely come close to freezing, sealed combustion operation is required. Concentric termination or separate terminations for combustion and vent, must be installed on the same wall or roof surface; however, never facing the direction of prevailing winds. Failure to do so may result in heat exchanger freezing and bursting. This failure is not covered under the manufacturer's warranty.



The use of cellular core PVC (ASTM F891), cellular core CPVC, or Radel® (polyphenolsulfone) in non-metallic venting systems is prohibited.

Covering non-metallic vent pipe and fittings with thermal insulation is prohibited.



**WARNING:**

**Appliance malfunction!**

- ▶ Protect the exhaust and inlet from leaves and debris by installing a screen on the end of the termination. ¼" mesh minimum opening recommended on screen.

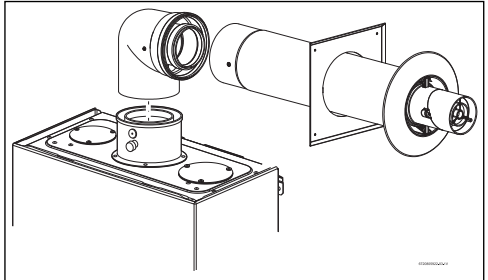

Fig. 8 PP Concentric up and out system

**4.3.1 Vent options**

This appliance can be installed as direct vent or Category IV.

The Greentherm are approved with the following venting options:

All combustion air and vent pipe materials and fittings must comply with the following:

Item	Material	United States	Canada
<b>Vent or air pipe and fitting</b>	<b>PP concentric single</b>		ULC-S636 certified only
	<b>PP common vent</b>		
	<b>PP twin pipe</b>		
	<b>PVC schedule 40</b>	ANSI/ASTM D1785	
	<b>PVC-DWV</b>	ANSI/ASTM D2665	
	<b>CPVC schedule 40</b>	ANSI/ASTM F441	
	<b>ABS-DWV schedule 40</b>	ANSI/ASTM D2661	
<b>Pipe cement / primer</b>	<b>PVC</b>	ANSI/ASTM D2564	
	<b>CPVC</b>	ANSI/ASTM F493	
	<b>ABS</b>	ANSI/ASTM D2235	

Table 5 Approved vent material

**For specific questions concerning vent material, specifications, usage or installation, please contact the vent manufacturer directly.**

The concentric up and out vent system simplifies installations where the water heater is mounted on an outside wall that can be direct vented through that wall. This vent system only consists of the concentric appliance adapter, one 90° elbow, and the termination, and can not be extended further.

**Concentric up and out kit: Part# 7 738 003 210**

The concentric up and out system must be installed according to the respective Installation Manual.

All vent connections must be glued, except for the PP vent systems, and the exhaust adapter (→chapter 4.3.4) which is screwed into place on the top of the appliance. Slide the vent pipe into the exhaust adapter. The exhaust pipe must be properly supported and must be pitched a minimum of a ¼ inch per foot back to the appliance. This allows the condensate to drain properly.

An optional concentric vent/air intake termination can be used for the installation of a vertical or horizontal venting system when using PVC, CPVC, or ABS (see fig. 9).

The concentric vent/air intake body can be ordered from your local wholesaler. Part# 196016 (3"/6") and Part #196006 (3"/5").

The appliance can also be installed with separate air intake and exhaust piping (see fig. 13, 20 and 21, page 29) in PP, PVC, CPVC, and ABS. Generic PP twin pipe can be used if certified to ULC-S636 and only with 90° elbow or T terminals. Maximum vent lengths and equivalent lengths per tables 9 and 10 apply.

**<Review>**

Description	Length	Kit part no. and quantity 196016
3- In. Rain Cap	N/A	1
4- In. Diameter SDR-26 Pipe	24 In. long	1
3- In. Y Concentric Fitting	N/A	1
2- ½ In. Diameter SDR-26 Pipe	37-1/8 in. long	1
3- In. Condensate drain Tee	N/A	1
1.5- In. Condensate drain bushing	N/A	1

Table 6 PVC concentric vent part breakdown

<Review>

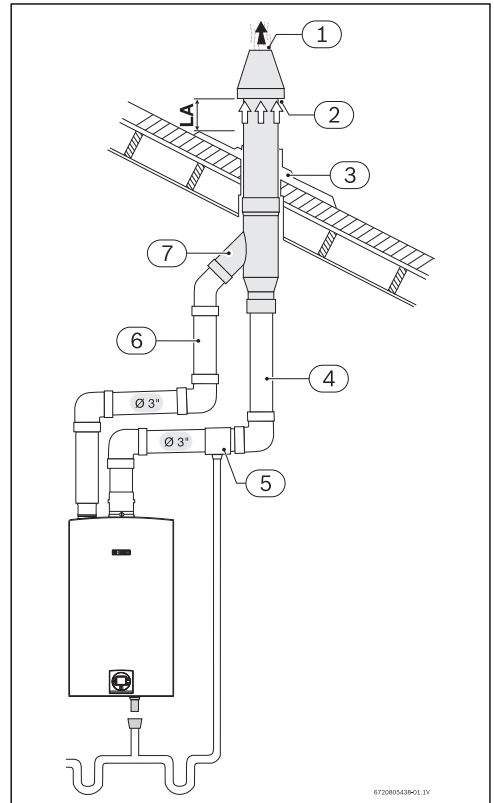

Fig. 9 Concentric vent kit example

- [1] Exhaust
- [2] Combustion air
- [3] Roof boot/flashing (field supplied)
- [4] Exhaust pipe
- [5] Drain tee (196061, included in concentric vent kits) as required. See chapter 4.3.2.
- [6] Intake pipe
- [7] Concentric vent kit (196016)
- [8] Maintain 12 in. (18 in. for Canada) minimum clearance above highest anticipated snow level maximum of 24 in. above roof

### 4.3.2 Vent specifications

Establish vent clearances that comply with the vent manufacturer's specifications and all applicable national/local codes.

#### Venting specifications

	Diam.	Approved terminals
<b>Exhaust</b>	3 or 4 inches	"T" terminal
	2, 3 or 4 inches	90° elbow
	3 inches	PVC Flue Cap*(ECAP321) Vertical terminations 3" diameter only
<b>Intake</b>	3 or 4 inches	Concentric (196016, 196006)
	3 or 4 inches	"T" terminal
<b>Exhaust</b>	2, 3 or 4 inches	90° elbow
	3 inches	PVC Flue Cap*(ECAP321) Vertical & horizontal terminations approved 3" diameter only
	3 or 4 inches	Concentric (196016, 196006)

[1] ULC S636-95, UL1738 certified

Table 7 Venting specifications for intake and exhaust

#### Condensate drain requirements

When the Water Heater is installed in a residential single family dwelling without direct recirculation an external condensate drain is not required.

If the Water Heater is installed in an application other than a residential single family dwelling an external condensate drain (not supplied with the Water Heater) is required in the following circumstances:

- Vertical terminating exhaust vent installations.
- Horizontal terminating exhaust vent installations greater than 6 feet (1.8 m) linear measurement, (NOT total equivalent length).
- Vent installations where any section of the exhaust vent pipe passes through an unconditioned space.

Note: An external condensate drain is recommended in all installations as best practice in order to maximize the longevity of the Water Heater.

#### Minimum combustion air and exhaust pipe length

The minimum exhaust pipe length is 1 foot (0.3m) of straight vent pipe. The minimum combustion air pipe length is one 90° elbow, except with the Common Vent System where the provided air intake grill cap is used.

#### Maximum combustion air and exhaust pipe length

The following tables display the maximum allowable straight pipe lengths for combustion air and exhaust piping with consideration to the number of elbows used. Reduce the equivalent length for each elbow used from the maximum allowable length depending on the system used.

Refer to table 8 if using 2" diameter venting.

Refer to table 9 if using 3" diameter venting.

Refer to table 10 if using 4" diameter venting.

2" Venting	Maximum allowable Exhaust pipe length	Combustion air pipe length	Elbow Equivalency	
			90°	45°
Twin pipe with two terminations	9.5ft	9.5ft	5 ft <sup>1)</sup> / 2.5 ft <sup>2)</sup>	2.5 ft

1) If using **90° short sweep elbow**.

2) If using **90° long sweep elbow**.

Table 8 Maximum Allowable Exhaust and Combustion Air Lengths for 2" PVC venting

3" Venting	Maximum allowable Exhaust pipe length	Combustion air pipe length	Elbow Equivalency	
			90°	45°
Twin pipe with two terminations	31ft	31ft	5 ft	3 ft
Twin pipe with concentric termination	23ft	23ft	5 ft	3 ft

Table 9 Maximum Allowable Exhaust and Combustion Air Lengths for 3" PP, PVC, CPVC, and ABS venting

4" Venting	Maximum allowable Exhaust pipe length	Combustion air pipe length	Elbow Equivalency	
			90°	45°
Twin pipe	63ft	63ft	2.5ft	1.5ft
Concentric	43ft	43ft	2.5ft	1.5ft

Table 10 Maximum Allowable Exhaust and Combustion Air Lengths for 4" PP, PVC, CPVC, and ABS venting

Review

**Use of elbows**

It is recommended to limit the amount of elbows used in the exhaust and combustion air piping to reduce friction in the air flow. The following lists the maximum amount of 90° elbows allowed in either the exhaust or combustion air piping:

Max. number of 90° elbows	2" venting	3" venting	4" venting
Twin pipe with two terminations	1 <sup>1)</sup> or 2 <sup>2)</sup>	5	7
Twin pipe with concentric termination	–	4	7

- 1) If using 90° **short sweep elbow**.
- 2) If using 90° **long sweep elbow**.

Table 11



**Two 45° elbows are equal to one 90° elbow. Any combination of 45° and 90° elbows may be used in the vent system as long as the combination does not exceed the maximum listed in table 11 above.**

**Calculation example for 3" PVC, CPVC, or ABS venting:**
**Exhaust**

System used	Twin pipe with
Number of 90° elbows needed:	1
Number of 45° elbows needed:	2

Table 12

Calculation of example	
Max. length	23'
90° elbow reduction	- 5'
sub-total =	18'
45° elbow reduction	- 6'
Total =	12'

Table 13



For this example, the maximum allowable exhaust pipe length is **12 feet**.

**Combustion air**

System used	Concentric
Number of 90° elbows needed:	2
Number of 45° elbows needed:	1

Table 14

Calculation of example	
Max. length	23'
90° elbow reduction	- 10'
sub-total =	13'
45° elbow reduction	- 3'
Total =	10'

Table 15



For this example, the maximum allowable combustion air pipe length is **10 feet**.

**Calculation example for 4" PP, PVC, CPVC, or ABS venting:**
**Exhaust**

System used	Twin pipe
Number of 90° elbows needed:	1
Number of 45° elbows needed:	2

Table 16

Calculation of example	
Max. length	63'
90° elbow reduction	- 2.5'
sub-total =	61.5'
45° elbow reduction	- 3'
Total =	58.5'

Table 17



For this example, the maximum allowable exhaust pipe length is **58.5 feet**.

**Combustion air**

System used	Twin pipe
Number of 90° elbows needed:	2
Number of 45° elbows needed:	2

Table 18

Calculation of example	
Max. length	63'
90° elbow reduction	- 5'
sub-total =	58'
45° elbow reduction	- 3'
Total =	55'

Table 19

**i** For this example, the maximum allowable combustion air pipe length is **55 feet**.

**Calculation example for 2" PVC venting:**

**Exhaust**

System used	Twin pipe
Number of 90° elbows needed:	1
Number of 45° elbows needed:	0

Table 20

Calculation of example	
Max. length	9.5'
90° elbow reduction	- 5'
sub-total =	4.5'
45° elbow reduction	- 0'
Total =	4.5'

Table 21

**i** For this example, the maximum allowable exhaust pipe length is **4.5 feet**.

**Combustion air**

System used	Twin pipe
Number of 90° elbows needed:	0
Number of 45° elbows needed:	2

Table 22

Calculation of example	
Max. length	9.5'
90° elbow reduction	- 0'
sub-total =	9.5'
45° elbow reduction	- 5'
Total =	4.5'

Table 23

**i** For this example, the maximum allowable combustion air pipe length is **4.5 feet**.

**<Review>**

**Required direct vent terminal clearances (twin pipe / concentric penetration) for PVC, CPVC, ABS, and PP.**

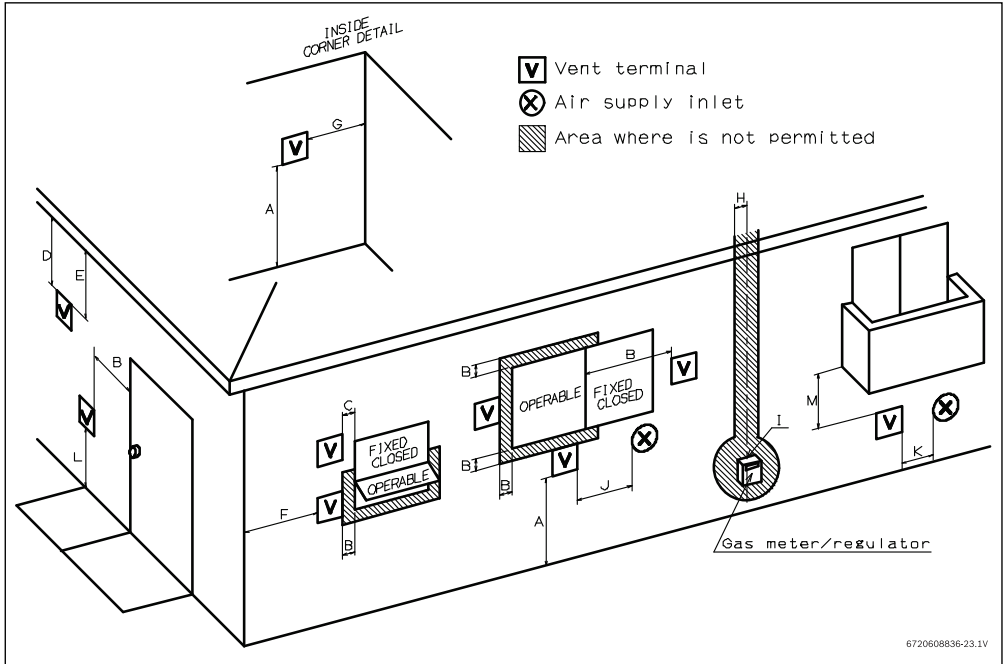

Fig. 10

Review >

	Canadian installations <sup>1)</sup>	U.S. installations <sup>2)</sup>
<b>A</b> Clearance above grade, veranda, porch, deck or balcony	12 in.	12 in.
<b>B</b> Clearance to window or door that may be opened	36 in.	12 in.
<b>C</b> Clearance to permanently closed window	*	*
<b>D</b> Vertical clearance to ventilated soffit located above the vent termination within a horizontal distance of 2 feet (61cm) from the center line of the termination	*	*
<b>E</b> Clearance to unventilated soffit	*	*
<b>F</b> Clearance to outside corner	*	*
<b>G</b> Clearance to inside corner	*	*
<b>H</b> Clearance to each side of center line extended above meter/regulator assembly	36 in. within a height 15 feet above meter/regulator assembly	*
<b>I</b> Clearance to service regulator vent outlet	36 in.	*
<b>J</b> Clearance to non-mechanical air supply inlet to building or the combustion air inlet to any other application	36 in.	12 in.
<b>K</b> Clearance to mechanical air supply inlet	72 in.	36 in. above if within 10 feet horizontally

		Canadian installations <sup>1)</sup>	U.S. installations <sup>2)</sup>
<b>L</b>	Clearance above paved sidewalk or paved driveway located on public property	84 in. <sup>3)</sup>	*
<b>M</b>	Clearance under veranda, porch deck or balcony	12 in. <sup>4)</sup>	*

- 1) In accordance with the current CSA B149.1 Natural Gas and Propane Installation Code.
  - 2) In accordance with the current ANSI Z223.1 / NFPA 54 National Fuel Gas Code.
  - 3) A vent shall not terminate directly above a sidewalk or paved driveway that is located between two single family dwellings and serves both dwellings.
  - 4) Permitted only if veranda, porch, deck or balcony is fully open on a minimum of two sides beneath the floor.
- [1] For clearances not specified in ANSI Z223.1 / NFPA 54 or CSA-B149.1, one of the following shall be indicated:
- a) A minimum clearance value determined by testing in accordance with section 2.20, or;
  - b) A reference to the following footnote:  
 “Clearance in accordance with local installation codes and the requirements of the gas supplier.”

Table 24

**<Review>**

**Required other than direct vent terminal clearances (single pipe penetration) for PVC, CPVC and ABS systems.**

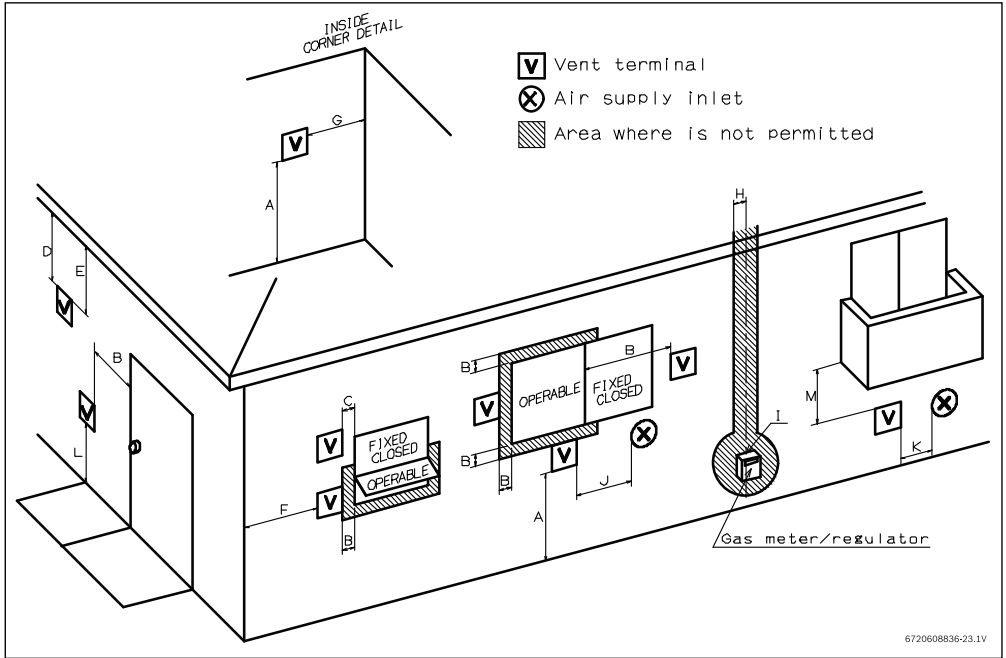

6720608836-23.1V

Fig. 11

**<Review >**

		Canadian installations <sup>1)</sup>	U.S. installations <sup>2)</sup>
<b>A</b>	Clearance above grade, veranda, porch, deck or balcony	12 in.	12 in.
<b>B</b>	Clearance to window or door that may be opened	36 in.	4 feet below or to side of opening; 1 foot above opening
<b>C</b>	Clearance to permanently closed window	*	*
<b>D</b>	Vertical clearance to ventilated soffit located above the vent termination within a horizontal distance of 2 feet (61 cm) from the center line of the termination	*	*
<b>E</b>	Clearance to unventilated soffit	*	*
<b>F</b>	Clearance to outside corner	*	*
<b>G</b>	Clearance to inside corner	*	*
<b>H</b>	Clearance to each side of center line extended above meter/regulator assembly	36 in. within a height 15 feet above meter/regulator assembly	*
<b>I</b>	Clearance to service regulator vent outlet	36 in.	*
<b>J</b>	Clearance to non-mechanical air supply inlet to building or the combustion air inlet to any other application	36 in.	4 feet below or to side of opening; 1 foot above opening

		Canadian installations <sup>1)</sup>	U.S. installations <sup>2)</sup>
<b>K</b>	Clearance to mechanical air supply inlet	72 in.	36 in. above if within 10 feet horizontally
<b>L</b>	Clearance above paved sidewalk or paved driveway located on public property	84 in. <sup>3)</sup>	84 in.
<b>M</b>	Clearance under veranda, porch deck or balcony	12 in. <sup>4)</sup>	*

1) In accordance with the current CSA B149.1 Natural Gas and Propane Installation Code

2) In accordance with the current ANSI Z223.1 / NFPA 54 National Fuel Gas Code

3) A vent shall not terminate directly above a sidewalk or paved driveway that is located between two single family dwellings and serves both dwellings.

4) Permitted only if veranda, porch, deck or balcony is fully open on a minimum of two sides beneath the floor.

[1] For clearances not specified in ANSI Z223.1 / NFPA 54 or CSA-B149.1, one of the following shall be indicated:

a) A minimum clearance value determined by testing in accordance with section 2.20, or;

b) A reference to the following footnote:

“Clearance in accordance with local installation codes and the requirements of the gas supplier.”

Table 25

**<Review>**

**4.3.3 Vent configuration examples for PP, PVC, CPVC, or ABS systems**

Below are approved examples of vertical and horizontal venting installations.

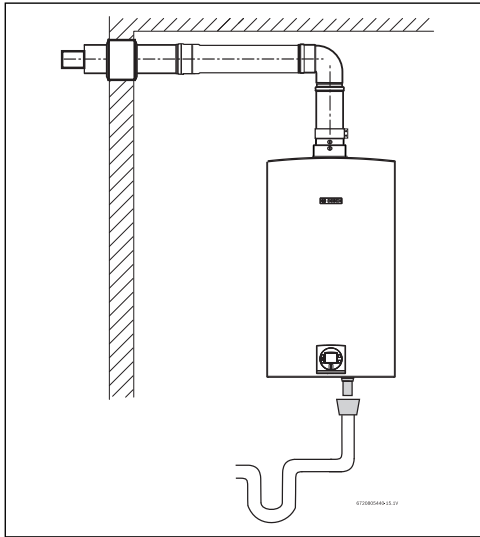

Fig. 12 PP concentric kit venting

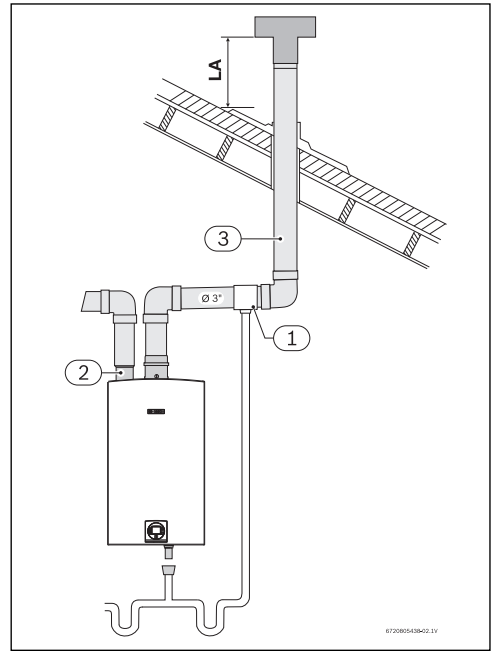

Fig. 13 Vertical venting system (single pipe penetration)

- [1] Drain tee (when required)
- [2] Intake
- [3] Exhaust
- [LA] Maintain 12 in. (18 in. for Canada) minimum clearance above highest anticipated snow level maximum of 24 in. above roof.

**NOTICE:**

**Using a single pipe vent in cold climates puts the water heater at risk of freezing, as negative air pressure is common in buildings during cold weather. This situation will pull cold air through the heat exchanger and can lead to damage and a water leak. Freeze damage to the water heater is not covered under warranty.**

**<Review >**

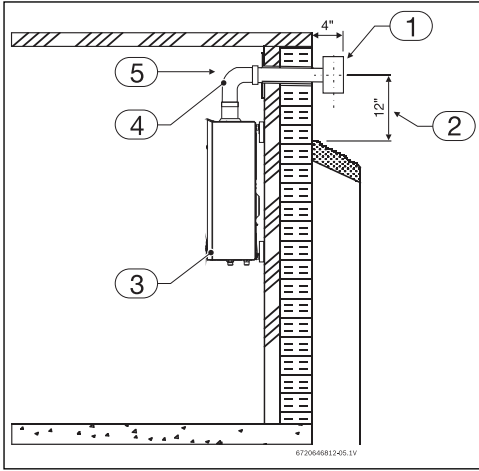

Fig. 14 Horizontal venting installation (combustion air piping not shown)

- [1] Termination
- [2] Minimum above ground or normally expected snow accumulation level
- [3] Appliance
- [4] Elbow (note: minimum 1ft of straight vent pipe required)
- [5] Horizontal run ¼" per foot down to termination

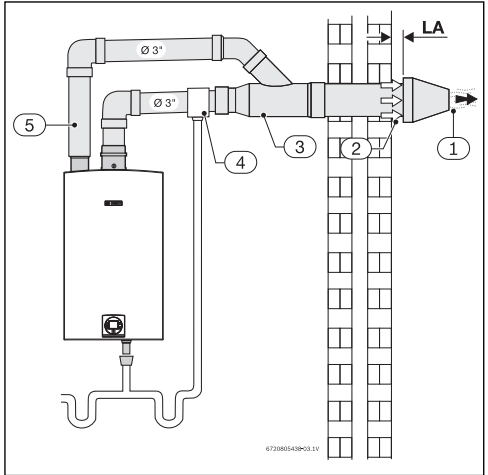

Fig. 15 Horizontal venting system (concentric vent)

- [1] Exhaust
- [2] Exhaust pipe
- [3] Exhaust pipe
- [4] Drain tee (when required)
- [5] Intake pipe
- [LA] Minimum 1"

**NOTICE:**

- ▶ The air intake connection on the concentric termination can be oriented in any possible direction.



**WARNING:**

- ▶ Single pipe penetration should be used in non-freezing climates only and steps must be taken to ensure that adequate combustion air is available to the water heater at all times!

**<Review>**

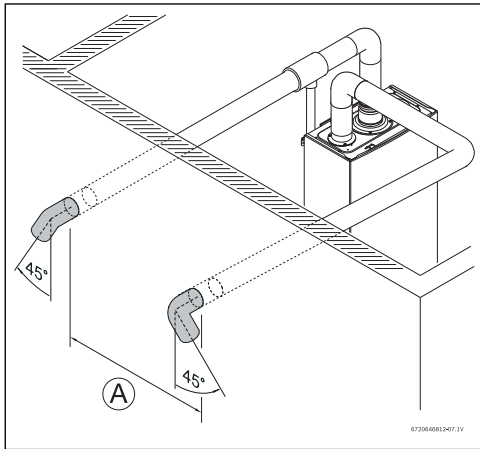

Fig. 16 Horizontal parallel venting system (twin pipe direct vent)

[A] 3 ft minimum

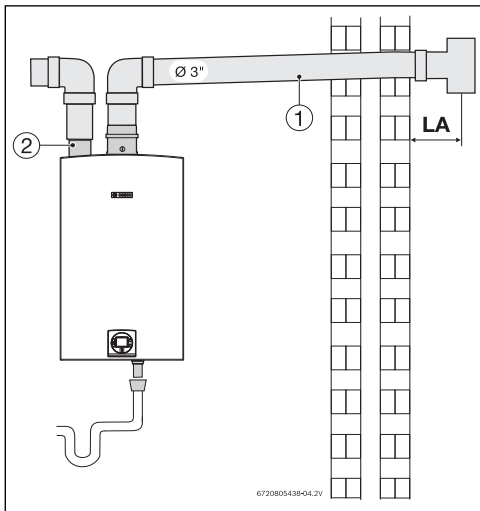

Fig. 17 Horizontal venting system (single pipe penetration)

- [1] Exhaust pipe
- [2] Intake pipe
- [LA] Minimum 4"

**NOTICE:**

**Risk of appliance freezing!**

- ▶ Single pipe penetration should be used in non-freezing climates only and steps must be taken to ensure that adequate combustion air is available to the water heater at all times!

**4.3.4 Vent connections for PP, PVC, CPVC, and ABS systems**

**Attaching the exhaust and air inlet connection adaptors to the top of the heater**

- ▶ Attach the flue gas exhaust accessory to the top of the unit fig. 18 (position 1) using the 4 screws and gasket provided, and fully insert vent pipe into the accessory. If using 4" venting, a 3" to 4" increaser should be installed directly after this accessory. If using 2" venting, a 3" to 2" reducer should be installed directly after this accessory. If using the PP twin pipe system, adapters from the appliance adapter (3" PVC compatible) to the PP system are needed.



NOTE: Vent pipe must be completely vertical when inserting or blue gasket inside exhaust accessory can become displaced. Exhaust accessory can be removed with vent pipe attached to check gasket position.

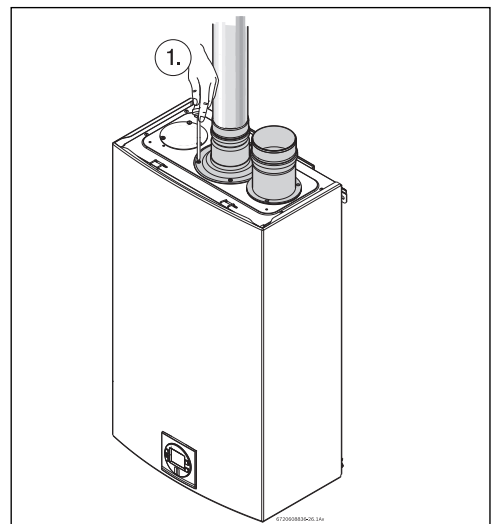

Fig. 18 Exhaust connection

**<Review>**

- ▶ Attach the combustion air inlet accessory to the top of the unit fig. 19 (position 2) using the 3 screws and gasket provided, and install 3" air intake pipe over the accessory.

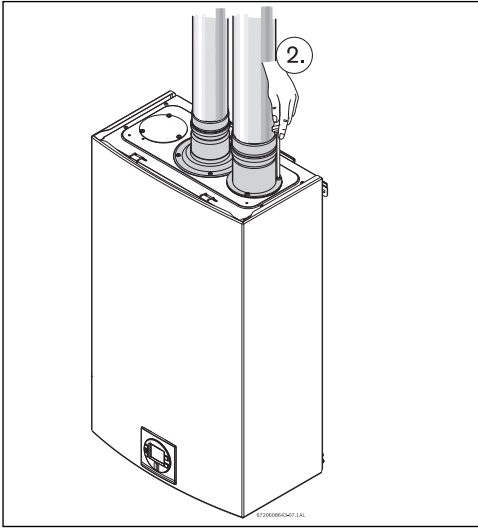

Fig. 19 Inlet connection



NOTE: The combustion air accessory can be installed on the top right or on the top left side of the heater. The combustion air inlet that is not used must be kept sealed.

#### 4.3.5 Connecting the condensate water drain

**NOTICE:**

**Risk of appliance freezing!**

- ▶ Failure to properly install condensate drain can damage the appliance and will void the warranty.

**NOTICE:**

**Risk of appliance freezing!**

- ▶ Do not install condensate drain tubing in areas where it may freeze.



The condensate must be disposed of in accordance with local codes.

See chapter 4.11 "Filling the condensate trap".



Use materials approved by the authority having jurisdiction. In the absence of other authority, PVC, and CPVC pipe must comply with ASTM D1785, F441 or D2665. Cement and primer must comply with ASTM D2564 or F493. For Canada, use CSA or ULC certified PVC or CPVC pipe, fittings and cement, see table 5.

PP pipe must be certified under ULC S636.

#### Appliance condensate drain installation

The appliance comes equipped with an internal condensate drain and siphon. This drains condensation formed in the secondary heat exchanger. Piping must be installed under the condensate drain outlet on the water heater and piped for disposal in accordance with local codes.

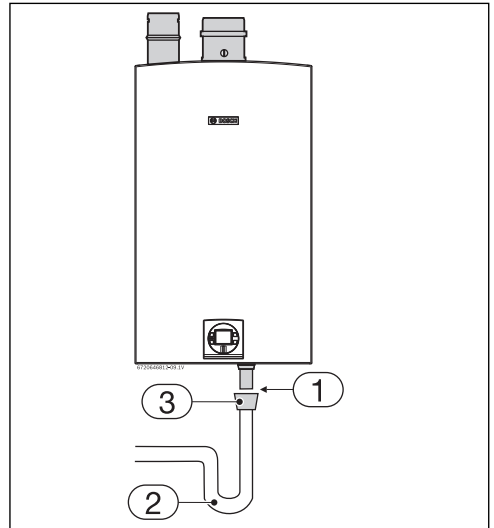

Fig. 20 Appliance drain installation

- [1] Leave minimum ¼" air gap
- [2] Trap required
- [3] 1 ½" x ½" PVC reducer

**<Review>**

**External condensate drain installation**

If an external condensate drain (installer supplied) must be installed (chapter 4.3.2), the following is recommended:

- 1. Install condensate drain on a horizontal section of the exhaust pipe as close to the heater as possible.
- 2. The condensate must be disposed of according to local codes.
- 3. To install condensate drain in vent system, use PVC 3" X 3" X 1.5" tee (part# 196278) and reduce for drain connection

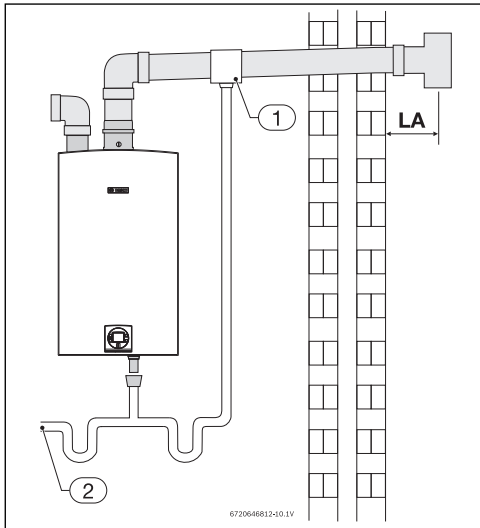

Fig. 21 External condensate drain installation

- [1] Condensate drain
- [2] Dispose of condensate in accordance with local codes
- [LA] Minimum 4"

**4.3.6 Freeze prevention for PVC, CPVC, and ABS systems**

In cold climates, components of a tankless water heater can freeze and burst from negative draft. A leading cause of negative draft is combustion appliances in the building not being supplied with sufficient combustion air. A wood stove or furnace can pull its combustion air from the water heater's vent pipe, allowing the cold incoming air to freeze the cold water in the heat exchanger. The best prevention for this risk is two pipe venting which draws the appliance combustion air from outside.

Listed below is an additional measure designed to further limit backdraft in conditions where there is a high risk of freeze damage.

**Backdraft reducer**

The Heat Fab backdraft reducer (9301BFP) is the preferred option for limiting backdraft (see fig. 22).

**Note: The following solution is available only for 3" diameter venting.**

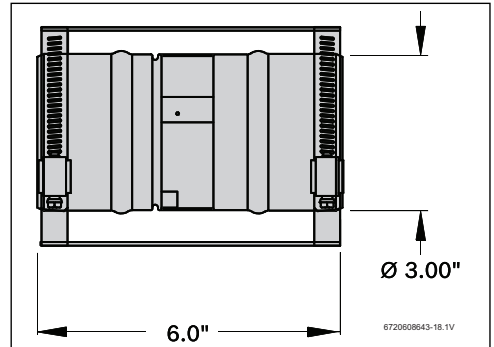

Fig. 22 Part # 9301BFP

**Installation**

For this solution to be effective, the internal flapper must be 100% closed when the water heater is not running. Refer to Figures 24 and 25 for preferred installation positions in the vent system.

Installation considerations:

- Install damper per the supplied manufacturer's instructions.
- The damper is only to be used in the exhaust vent piping.
- Ensure directional arrow on damper label faces in the same direction as exhaust flow.
- If installed horizontally, the axis must be horizontal or slightly pitched up towards termination to ensure damper closes 100% when heater is not running.
- To allow accessibility, damper must not be installed in an enclosed section of vent pipe.
- Do not install damper in unconditioned spaces (e.g. attics) Condensation can build up while the heater is running which can later freeze and potentially block the flapper.

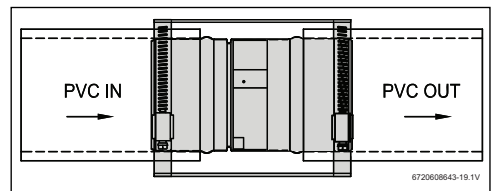

Fig. 23 Backflow reducer (9301BFP) installed

**<Review>**

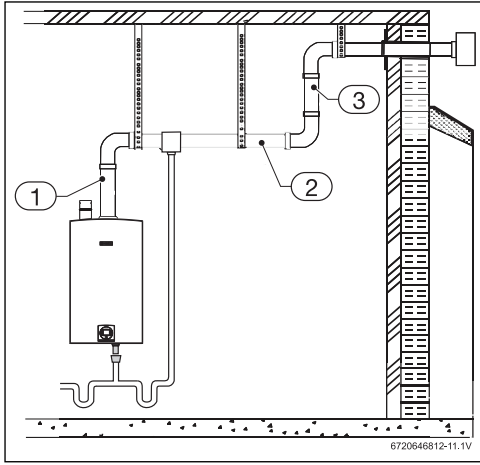

Fig. 24

- [1] Good
- [2] Better
- [3] Best

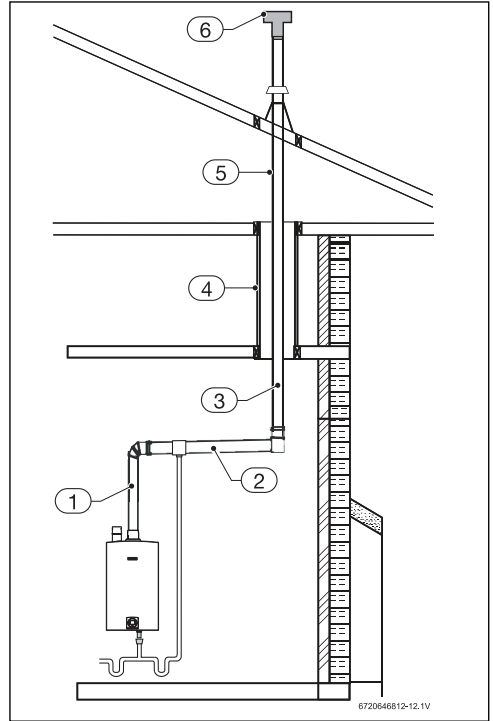

Fig. 25

- [1] Good
- [2] Better
- [3] Best
- [4] Enclosed vent pipe (Do not install damper)
- [5] Unconditioned space (Do not install damper)
- [6] Preferred damper position for vertical terminations

**<Review>**

**4.3.7 Common venting of 2 to 4 units**

2 to 4 unit cascades can be common vented using the optional PP common venting system. The water heaters can be installed in a back to back configuration as shown in fig. 27, or side by side as shown in fig. 28. The systems are custom configurable for vent lengths from 40" (1m) up to 100' (30m) and either a vertical or horizontal termination (see fig. 26).

The following configurations are available:

Units	Configurations
2	Back to Back
4	Back to Back - see fig. 27
2	Side by Side - see fig. 26
3	Side by Side
4	Side by Side - see fig. 28

Table 26

Where no empty wall space is available a powder coated steel racking system is also available for water heaters in side by side or back to back configurations. See the respective product brochure for details.

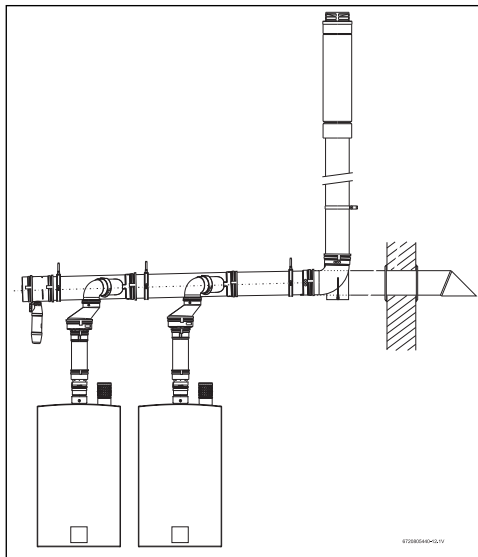

Fig. 26 Common venting for 2 to 4 water heaters available with vertical or horizontal termination

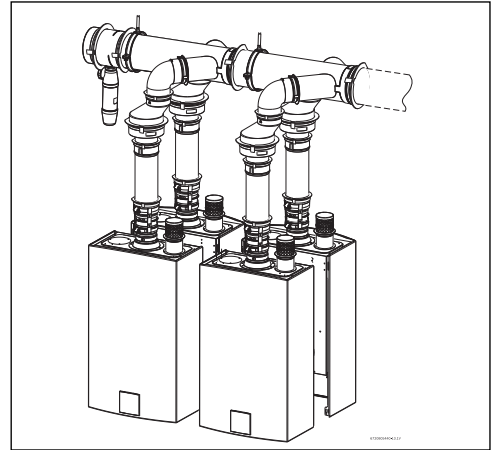

Fig. 27 Back to back configuration

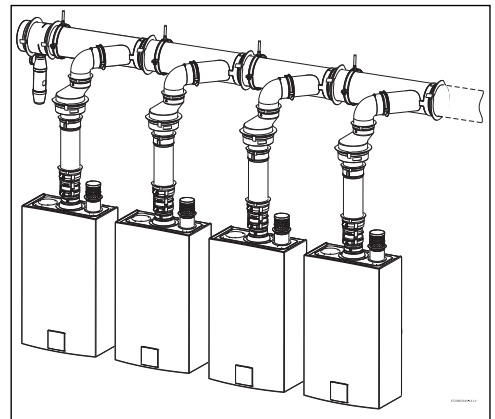

Fig. 28 Side by side configuration

For available parts and configurations see the Greentherm Common Vent Bulletin available on [www.boschheatingandcooling.com](http://www.boschheatingandcooling.com).

**NOTICE:**

**Drawings 26 to 28 depict the conceptual configurations available.**

- For installation details and requirements consult the respective common vent installation instructions listed below.

**<Review >**

Content	Document number	Part number
Side by side basic kit	6 720 804 523	7 736 501 100
Side by side extension kit	6 720 804 524	7 736 501 254
Back to back basic kit	6 720 804 520	7 736 501 253
Back to back extension kit	6 720 804 522	7 736 501 252

Table 27

### 4.3.8 Fan speed adjustment

**NOTICE:**

**IMPORTANT INFORMATION!**

- ▶ Natural gas heaters with installation altitudes below 2,000 ft above sea level disregard this section.

**Installation adjustment:**

After installing the tankless water heater, the fan speed values for minimum power (P2) and maximum power (P1) may need adjustment due to variations in altitude and vent pipe length.

Failure to make necessary adjustments to fan speed values may result in improper operation of the appliance.

First calculate the total equivalent vent length. This is the straight pipe length of both exhaust and combustion air plus the number of elbows used. To determine the length equivalency of each elbow refer to tables 9 and 10.

Use the equivalent vent length value to determine the appropriate fan speed values found in table 29 and 30. Refer to page 36 on how to adjust the fan speeds if an adjustment is necessary. After changing fan speed values, proceed to chapter 7.5 to confirm CO<sub>2</sub> values are within specified ranges.

**C 1050ES (Pro TL 199 C) Fan Speed Adjustment**

Altitude (above sea level)	Vent terminal	Total equivalent vent length <sup>1)</sup>	Natural Gas	Liquid propane	Natural Gas	Liquid propane
			Minimum power fan speed (P2)	Minimum power fan speed (P2)	Maximum power fan speed (P1)	Maximum power fan speed (P1)
0 - 2000 ft (0 - 610 m)	Twin system	3.5 - 11 ft	12 <sup>3)</sup>	17 <sup>3)</sup>	52 <sup>3)</sup>	52 <sup>3)</sup>
		12 - 19 ft	12 <sup>3)</sup>	17 <sup>3)</sup>	52 <sup>3)</sup>	52 <sup>3)</sup>
2000 - 4500 ft <sup>2)</sup> (610 - 1372 m)	Twin system	3.5 - 11 ft	13 <sup>3)</sup>	17 <sup>3)</sup>	52 <sup>3)</sup>	52 <sup>3)</sup>
		12 - 19 ft	13 <sup>3)</sup>	17 <sup>3)</sup>	52 <sup>3)</sup>	52 <sup>3)</sup>

**<Review>**

- 1) Full equivalent length (inlet + outlet piping + fittings)
- 2) When installing in altitude, the unit may not reach the rated Input
- 3) When adjusting the unit, CO<sub>2</sub> levels must be checked with a combustion gas analyzer, see chapter 7.5 for instructions.

Table 28 C 1050ES (Pro TL 199 C) Fan speed adjustment for 2" piping

Altitude (above sea level)	Vent terminal	Total equivalent vent length <sup>1)</sup>	Natural Gas	Liquid propane	Natural Gas	Liquid propane
			Minimum power fan speed (P2)	Minimum power fan speed (P2)	Maximum power fan speed (P1)	Maximum power fan speed (P1)
0 - 2000 ft (0 - 610 m)	Concentric	6 - 25 ft	No modification required on installations below 2000 ft Altitude			
		26 - 46 ft				
	Twin system	6 - 37 ft				
		38 - 62 ft				

Altitude (above sea level)	Vent terminal	Total equivalent vent length <sup>1)</sup>	Natural Gas	Liquid propane	Natural Gas	Liquid propane	
			Minimum power fan speed (P2)	Minimum power fan speed (P2)	Maximum power fan speed (P1)	Maximum power fan speed (P1)	
2000 - 4500 ft (610 - 1372 m)	Concentric	6 - 25 ft	11*	14*	52*	52*	For operation at elevations above 2,000 ft (610 m) the equipment ratings shall be reduced at the rate of 4% for each 1,000 ft (305 m) above sea level
		26 - 46 ft	11*	14*	53*	53*	
	Twin system	6 - 37 ft	10*	13*	52*	52*	
		38 - 62 ft	11*	14*	53*	53*	
4500 - 8000 ft (1372 - 2439 m)	Concentric	6 - 25 ft	11*	14*	53*	53*	
		26 - 46 ft	13*	16*	53*	53*	
	Twin system	6 - 37 ft	11*	14*	53*	53*	
		38 - 62 ft	12*	15*	53*	53*	

\* Above 2000 ft, CO2 levels must be checked with a combustion gas analyzer, see chapter 7.5 for instructions.

1) Full equivalent length (inlet + outlet piping + fittings)

Table 29 C 1050ES (Pro TL 199 C) Fan speed adjustment for 3" piping

Altitude (above sea level)	Vent terminal	Total equivalent vent length <sup>1)</sup>	Natural Gas	Liquid propane	Natural Gas	Liquid propane	
			Minimum power fan speed (P2)	Minimum power fan speed (P2)	Maximum power fan speed (P1)	Maximum power fan speed (P1)	
0 - 2000 ft (0 - 610 m)	Concentric	3.5 - 39 ft	No modification required on installations below 2000 ft Altitude				
		40 - 86 ft					
	Twin system	3.5 - 59 ft					
		60 - 126 ft					
2000 - 4500 ft (610 - 1372 m)	Concentric	3.5 - 39 ft	11*	14*	52*	52*	For operation at elevations above 2,000 ft (610 m) the equipment ratings shall be reduced at the rate of 4% for each 1,000 ft (305 m) above sea level
		40 - 86 ft	11*	14*	53*	53*	
	Twin system	3.5 - 59 ft	10*	13*	52*	52*	
		60 - 126 ft	11*	14*	53*	53*	
4500 - 8000 ft (1372 - 2439 m)	Concentric	3.5 - 39 ft	11*	14*	53*	53*	
		40 - 86 ft	13*	16*	53*	53*	
	Twin system	3.5 - 59 ft	11*	14*	53*	53*	
		60 - 126 ft	12*	15*	53*	53*	

\* Above 2000 ft, CO2 levels must be checked with a combustion gas analyzer, see chapter 7.5 for instructions.

1) Full equivalent length (inlet + outlet piping + fittings)

Table 30 Fan speed adjustment for 4" piping

**C 950ES (Pro TL 175 C) Fan Speed Adjustment**

Altitude (above sea level)	Vent terminal	Total equivalent vent length <sup>1)</sup>	Natural Gas	Liquid propane	Natural Gas	Liquid propane	
			Minimum power fan speed (P2)	Minimum power fan speed (P2)	Maximum power fan speed (P1)	Maximum power fan speed (P1)	
0 - 2000 ft (0 - 610 m)	Twin system	3.5 - 11 ft	12 <sup>3)</sup>	17 <sup>3)</sup>	48 <sup>3)</sup>	48 <sup>3)</sup>	
		12 - 19 ft	12 <sup>3)</sup>	17 <sup>3)</sup>	48 <sup>3)</sup>	48 <sup>3)</sup>	
2000 - 4500 ft <sup>2)</sup> (610 - 1372 m)	Twin system	3.5 - 11 ft	13 <sup>3)</sup>	17 <sup>3)</sup>	48 <sup>3)</sup>	48 <sup>3)</sup>	
		12 - 19 ft	13 <sup>3)</sup>	17 <sup>3)</sup>	49 <sup>3)</sup>	49 <sup>3)</sup>	

- 1) Full equivalent length (inlet + outlet piping + fittings)
- 2) When installing in altitude, the unit may not reach the rated Input
- 3) When adjusting the unit, CO2 levels must be checked with a combustion gas analyzer, see chapter 7.5 for instructions.

Table 31 C 950ES (Pro TL 175 C) Fan speed adjustment for 2" piping

Altitude (above sea level)	Vent terminal	Total equivalent vent length <sup>1)</sup>	Natural Gas	Liquid propane	Natural Gas	Liquid propane	
			Minimum power fan speed (P2)	Minimum power fan speed (P2)	Maximum power fan speed (P1)	Maximum power fan speed	
0 - 2000 ft (0 - 610 m)	Concentric	6 - 25 ft	No modification required on installations below 2000 ft Altitude				
		26 - 46 ft					
	Twin system	6 - 37 ft					
		38 - 62 ft					
2000 - 4500 ft (610 - 1372 m)	Concentric	6 - 25 ft	11*	14*	47*	47*	For operation at elevations above 2,000 ft (610 m) the equipment ratings shall be reduced at the rate of 4% for each 1,000 ft (305 m) above sea level
		26 - 46 ft	11*	14*	48*	48*	
	Twin system	6 - 37 ft	10*	13*	47*	47*	
		38 - 62 ft	11*	14*	48*	48*	
4500 - 8000 ft (1372 - 2439 m)	Concentric	6 - 25 ft	11*	14*	48*	48*	
		26 - 46 ft	13*	16*	48*	48*	
	Twin system	6 - 37 ft	11*	14*	48*	48*	
		38 - 62 ft	12*	15*	48*	48*	

\* Above 2000 ft, CO2 levels must be checked with a combustion gas analyzer, see chapter 7.5 for instructions.

- 1) Full equivalent length (inlet + outlet piping + fittings)

Table 32 C 950ES (Pro TL 175 C) Fan speed adjustment for 3" piping

**<Review>**

Altitude (above sea level)	Vent terminal	Total equivalent vent length <sup>1)</sup>	Natural Gas	Liquid propane	Natural Gas	Liquid propane	
			Minimum power fan speed (P2)	Minimum power fan speed (P2)	Maximum power fan speed (P1)	Maximum power fan speed (P1)	
0 - 2000 ft (0 - 610 m)	Concentric	3.5 - 39 ft	No modification required on installations below 2000 ft Altitude				
		40 - 86 ft					
	Twin system	3.5 - 59 ft					
		60 - 126 ft					
2000 - 4500 ft (610 - 1372 m)	Concentric	3.5 - 39 ft	11*	14*	47*	47*	For operation at elevations above 2,000 ft (610 m) the equipment ratings shall be reduced at the rate of 4% for each 1,000 ft (305 m) above sea level
		40 - 86 ft	11*	14*	48*	48*	
	Twin system	3.5 - 59 ft	10*	13*	47*	47*	
		60 - 126 ft	11*	14*	48*	48*	
4500 - 8000 ft (1372 - 2439 m)	Concentric	3.5 - 39 ft	11*	14*	48*	48*	
		40 - 86 ft	13*	16*	48*	48*	
	Twin system	3.5 - 59 ft	11*	14*	48*	48*	
		60 - 126 ft	12*	15*	48*	48*	
* Above 2000 ft, CO2 levels must be checked with a combustion gas analyzer, see chapter 7.5 for instructions.							

1) Full equivalent length (inlet + outlet piping + fittings)

Table 33 Fan speed adjustment for 4" piping

<Review >

**PP Concentric up and out venting - Only for C 1050 (Pro TL 199 C)**

Altitude	NG P2	LP P2	NG P1	LP P1
0 - 2000	no change	no change	no change	50
2000 - 4500	no change	no change	no change	50
4500 - 8000	no change	no change	no change	50

Table 34 Fan speed adjustment for concentric up and out vent

**Cascade common venting system - C 1050 (Pro TL 199 C)**

Altitude	Total equivalent length	NG P2	LPP2	NG P1	LP P1
0 - 2000	4 - 100ft	19	19	no change	no change
2000 - 4500	4 - 100ft	20	20	52	53
4500 - 8000	4 - 100ft	20	20	53	53

Table 35 Fan speed adjustment for cascade vent

**Cascade common venting system - C 950 (Pro TL 175 C)**

Altitude	Total equivalent length	NG P2	LP P2	NG P1	LP P1
0 - 2000	4 - 100ft	19	19	no change	no change
2000 - 4500	4 - 100ft	20	20	47	47
4500 - 8000	4 - 100ft	20	20	48	48

Table 36 Fan speed adjustment for cascade vent

**Adjusting minimum power fan speed (P2)**

To select fan speed:

- ▶ Press ON/OFF button  into ON.
- ▶ Press and hold simultaneously buttons ,  and  for 3 seconds, until display reads P2.

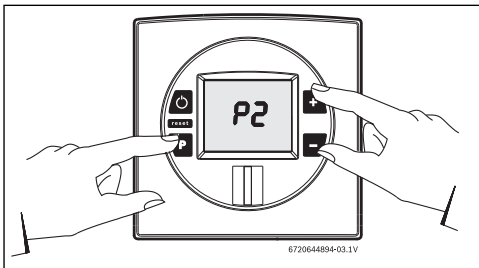





Fig. 29

- ▶ Press  to enter P2 adjustment. The current setting will appear on the display (factory default).

- ▶ Press  or  to choose the fan speed suitable with your installation, see table 29 and 30.
- ▶ Press and hold ( $\pm$  5 sec.) "Program" button  until the display flashes, then the selected value is memorized.



Proceed directly to chapter 7.5 to confirm CO<sub>2</sub> values are within range.

**Adjusting maximum power fan speed (P1)**

To select fan speed:

- ▶ Press ON/OFF button  into ON.
- ▶ Press and hold simultaneously buttons ,  and  for 3 seconds, until display reads P2.

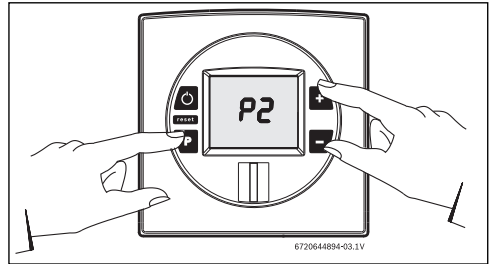







Fig. 30

- ▶ Press the minus button  to display P1.
- ▶ Press "Program" button  to enter P1 adjustment. The current setting will appear on the display.
- ▶ Press  or  to choose the fan speed suitable with your installation, see table 29 and 30.
- ▶ Press and hold ( $\pm$  5 sec.) "Program" button  until the display flashes, then the selected value is memorized.



Proceed directly to chapter 7.5 to confirm CO<sub>2</sub> values are within range.

**<Review>**

**Attention residents of the Commonwealth of Massachusetts:**

In the Commonwealth of Massachusetts the following regulation went into effect on 12/30/2005:

(a) For all side wall horizontally vented gas fueled equipment installed in every dwelling, building or structure used in whole or in part for residential purposes, including those owned or operated by the Commonwealth and where the side wall exhaust vent termination is less than seven (7) feet above finished grade in the area of the venting, including but not limited to decks and porches, the following requirements shall be satisfied:

1. **INSTALLATION OF CARBON MONOXIDE DETECTORS.** At the time of installation of the side wall horizontal vented gas fueled equipment, the installing plumber or gas fitter shall observe that a hard wired carbon monoxide detector with an alarm and battery back-up is installed on the floor level where the gas equipment is to be installed. In addition, the installing plumber or gas fitter shall observe that a battery operated or hard wired carbon monoxide detector with an alarm is installed on each additional level of the dwelling, building or structure served by the side wall horizontal vented gas fueled equipment. It shall be the responsibility of the property owner to secure the services of qualified licensed professionals for the installation of hard wired carbon monoxide detectors.

a. In the event that the side wall horizontally vented gas fueled equipment is installed in a crawl space or an attic, the hard wired carbon monoxide detector with alarm and battery back-up may be installed on the next adjacent floor level.

b. In the event that the requirements of this subdivision cannot be met at the time of completion of installation, the owner shall have a period of thirty (30) days to comply with the above requirements; provided, however, that during said thirty (30) day period, a battery operated carbon monoxide detector with an alarm shall be installed.

2. **APPROVED CARBON MONOXIDE DETECTORS.** Each carbon monoxide detector as required in accordance with the above provisions shall comply with NFPA 720 and be ANSI/UL 2034 listed and IAS certified.

3. **SIGNAGE.** A metal or plastic identification plate shall be permanently mounted to the exterior of the building at a minimum height of eight (8) feet above grade directly in line with the exhaust vent terminal for the horizontally vented gas fueled heating appliance or equipment. The sign shall read, in print size no less than one half (1/2) inch in size, "GAS VENT DIRECTLY BELOW. KEEP CLEAR OF ALL OBSTRUCTIONS".

4. **INSPECTION.** The state or local gas inspector of the side wall horizontally vented gas fueled equipment shall not approve the installation unless, upon inspection, the inspector observes carbon monoxide detectors and signage installed in accordance with the provisions of 248 CMR 5.08(2)(a)1 through 4.(b)

EXEMPTIONS: The following equipment is exempt from 248

CMR 5.08(2)(a)1 through 4:

1. The equipment listed in Chapter 10 entitled "Equipment Not Required To Be Vented" in the most current edition of NFPA 54 as adopted by the Board; and

2. Product approved side wall horizontally vented gas fueled equipment installed in a room or structure separate from the dwelling, building or structure used in whole or in part for residential purposes.

(c) **MANUFACTURERS REQUIREMENTS - GAS EQUIPMENT VENTING SYSTEM REQUIRED.** When the manufacturer of Product Approved side wall horizontally mounted gas equipment provides a venting system design or venting system components with the equipment, the instructions provided by the manufacturer for the installation of the equipment and the venting shall include:

1. Detailed instructions for the installation of the venting system or the venting system components: and

2. A complete parts list for the venting system design or venting system. (d) **MANUFACTURER REQUIREMENTS - GAS EQUIPMENT VENTING SYSTEM NOT PROVIDED.** When the manufacturer of a product approved side wall horizontally vented gas fueled equipment does not provide the parts for the venting of flue gases, but identifies "special venting systems," the following requirements shall be satisfied by the manufacturer:

1. The referenced "special venting system" instructions shall be included with the appliance or equipment installation instructions; and

2. The "special venting systems" shall be product approved by the Board, and the instructions for that system shall include a parts list and detailed installation instructions.

(e) A copy of all installation instructions for all products approved side wall horizontally vented gas fueled equipment, all venting instructions, all parts lists for venting instructions, and/or all venting design instructions shall remain with the appliance or equipment at the completion of the installation.

## 4.4 Combustion air requirements

### NOTICE:

- ▶ In areas where outside temperatures routinely come close to freezing, sealed combustion operation is required. Use a concentric termination or separate terminations for combustion and vent, which must be installed on the same wall or roof surface, however never facing the direction of prevailing winds. Failure to do so may result in heat exchanger freezing up and leaking. This failure is not covered under the manufacturer's warranty.

### NOTICE:

- ▶ When installed in an environment where corrosive chemicals or dirty air (e.g. hair salons, car washes) are present the twin pipe system is required.

### Twin pipe and Concentric pipe

The water heater is designed as a sealed combustion appliance. It is recommended that the combustion air be provided by a dedicated 2", 3" or 4" pipe from the outside (twin pipe) or by connecting to the Concentric vent kit (see fig. 9). The combustion air pipe may be PVC or any other rigid sealed 2", 3" or 4" pipe. The combustion air piping must pitch down 1/4 inch per foot towards termination to prevent rain water from entering the appliance. In twin pipe penetrations, the combustion air inlet, whether terminating vertically or horizontally, must be located in such a manner as to provide a minimum 3 foot clearance from the exhaust vent termination. See fig. 10 and 11 Letter I, page 21. For the maximum length of the combustion air pipe, see tables 8, 9 & 10.



### CAUTION:

- ▶ Terminations must prevent rain and debris from entering the combustion air and exhaust vent piping.

### Single pipe

Note: These appliances require substantial combustion air to operate. The C 950 (Pro TL 175 C) requires 8750 cubic feet, or 1094 square feet with an 8 foot ceiling. The C 1050 (Pro TL 199 C) requires 9950 cubic feet, or 1243 square feet an 8 foot ceiling. If the large amount of air space, which equates to about half of most average sized homes, is not available, the appliance must pull air from the outside (see twin pipe above).

Although it is permissible to draw combustion air from the inside, it is not the manufacturer's recommended installation method. Always install a 3 inch 90° elbow on the top of the combustion air inlet adaptor to prevent foreign objects from falling into the unit.

If a single pipe installation is utilized, follow guidelines below for providing adequate combustion air for the water heater as well as any other appliances that may consume air in the same space. Always follow local codes if they are more stringent and regulations.

#### • Appliances located in unconfined spaces:

- **a)** An unconfined space is one whose volume is greater than 50 cubic feet (1.42 cubic meter) per 1000 BTU/hr (292.81 Watts) of the combined rating of all appliances installed in the space. That would be 9950 cubic feet (281.8 cubic meters) for the water heater alone.
- **b)** In unconfined spaces in buildings of conventional frame, masonry, or metal construction, infiltration air is normally adequate to provide air for combustion.

#### • Appliances located in confined spaces:

The confined space must be provided with two permanent openings, one commencing within 12 inches (304.8mm) of the top and one commencing within 12 inches (304.8mm) of the bottom of the enclosure. Each opening must have a minimum free area of one square inch per:

- 1000 BTU/hr (292.81 Watts) if all air is taken from inside the building
- 2000 BTU/hr (585.62 Watts) if all air is taken from the outside by horizontal ducts
- 4000 BTU/hr (1171.24 Watts) if all air is taken from the outside by direct openings or vertical ducts

Or the confined space must be provided with one permanent opening or duct that is within 12 inches (304.8mm) of the ceiling of the enclosure. This opening must have a minimum free area of one square inch per:

- 3000 BTU/hr (878.43 Watts) if all air is taken from the outside by a direct opening or vertical duct.

Louvers, grills and screens have a blocking effect, when used, increase the sizes of your openings by 300% for wood louvers (as wood type will reduce the free air by 75%) and 43% for metal louvers (as metal will reduce the free air by 30%). Refer to the National Fuel Gas Code for complete information. In buildings of tight construction all air should be taken from outside.

Review

#### 4.5 Proper location for installing your heater

Carefully select the location of the water heater. For your safety and for proper heater operation, you must provide combustion air to the heater and a proper exhaust vent system.

Follow the guidelines below:

- ▶ **1.** Locate the heater where venting, gas and plumbing connections are feasible and convenient.
- ▶ **2.** The hot water lines should be kept short and insulated to save energy. It is recommended to locate the water heater as close as practical to the most frequently used hot water fixtures.

#### NOTICE:

##### Risk of appliance freezing!

- ▶ The water in this water heater is cold and always remains cold except for the times the burner is on. In the event of power outage in conjunction with freezing temperatures, it is recommended that the heater be drained. See chapter 7.2, page 57 "Winterizing" for draining instructions.



#### WARNING:

- ▶ Flammable materials, gasoline, pressurized containers, or any other items or articles that are potential fire hazards must NOT be placed on or adjacent to the heater. The appliance area must be kept free of all combustible materials, gasoline and other flammable vapors and liquids.

#### 4.6 Heater placement and clearances

The water heater design is approved for installation on a combustible wall (see chapter 4.7 Mounting installation) provided the floor covering below the heater is noncombustible.

For installations in an alcove or closet, maintain the minimum clearances to combustible and non-combustible materials. See fig. 6, page 14.

#### 4.7 Hanging appliance on the wall



#### WARNING:

##### Severe personal injury and property damage!

Before mounting appliance:

- ▶ Check that there are no loose or damaged parts inside the appliance.
- ▶ Confirm that the gas type of the heater matches the gas supply you will be connecting the heater, see fig. 2, page 11.



Front cover should be removed (see instructions on page 12) in order to inspect components visually.



#### WARNING:

- ▶ Do not install this appliance on a carpeted wall. The heater must be mounted on a wall using appropriate anchoring materials.

#### NOTICE:

##### Risk of appliance freezing!

- ▶ In areas where outside temperature is routinely below 32°F (0°C) and the heater is to be installed on the inside of an exterior wall, a minimum 2" air gap or rigid insulation between the heater back and the wall is recommended.

If wall is sheathed with plaster or drywall, it is recommended that two support boards, either 1"x 4" or 1/2" (minimum) plywood first be attached across a pair of studs, see fig. 31, page 40.

- ▶ Secure the wall mounting bracket provided with the heater to a wall surface. The heater must be kept level on the wall surface, see fig. 32, page 40.
- ▶ Hang the appliance on the bracket, see fig. 33, page 41.

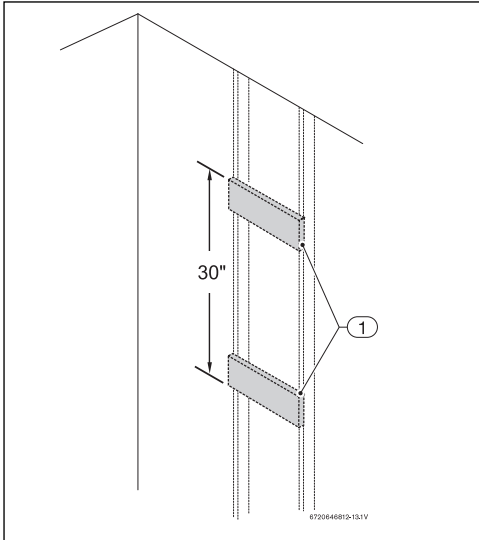

Fig. 31 Distance between support boards

[1] Studs 16" (406mm) on center

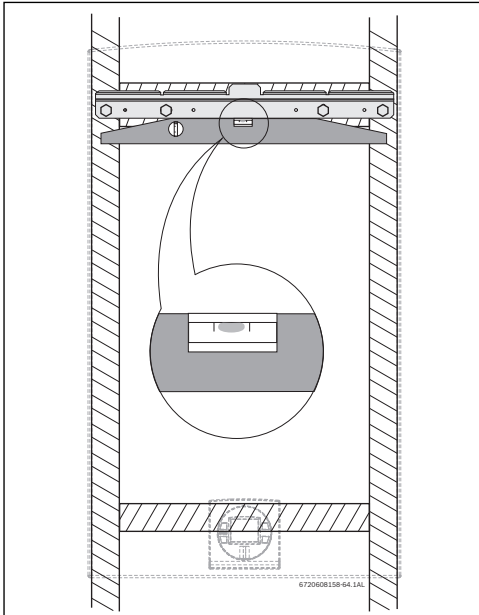

Fig. 32 Leveling wall mounting bracket

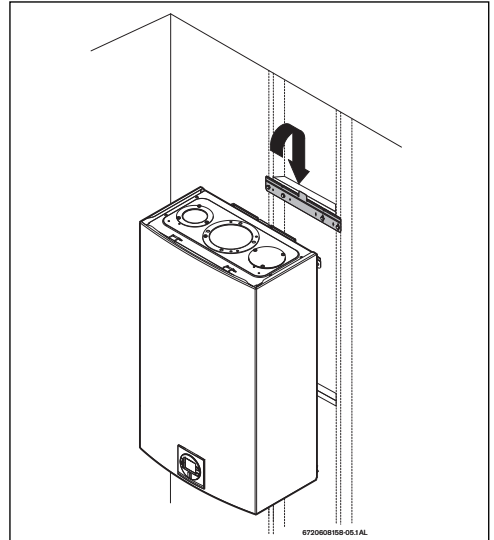

Fig. 33 Mounting the heater



**CAUTION:**

**Personal injury and property damage.**

- ▶ Appliance must be installed vertically.

**4.8 Gas piping & connections**



Before connecting the gas supply, check the rating plate on the right side of the heater to be sure that the heater is rated for the same gas to which it will be connected.

In the United States: The installation must conform with local codes or, in the absence of local codes, the National Fuel Gas Code ANSI Z223.1/NFPA 54.

In Canada: The Installation must conform to CGA B149 INSTALLATION CODES and/or local installation codes.



**DANGER:**

**Explosion hazard!**

- ▶ DO NOT connect to an unregulated or high pressure propane line or to a high pressure commercial natural gas line.

**<Review>**

**! DANGER:**

**Explosion hazard!**

- ▶ The heater must be isolated from the gas supply piping system during any pressure testing of that system at test pressures equal to or more than 0.5 psig. If overpressure has occurred, such as through improper testing of the gas lines or malfunction of the supply system, the gas valve must be checked for safe operation.

**! DANGER:**

**Explosion hazard!**

- ▶ If you detect a leak, shut off the gas. Tighten appropriate fittings to stop leak. Turn the gas on and check again with a gas leak detection solution. Never test for gas leaks using a match or flame.

**GAS CONNECTIONS**

- ▶ Install a manual gas shut off valve on the gas supply line within easy reach of the appliance.
- ▶ Install a union when connecting gas supply.
- ▶ The minimum internal diameter required for any appliance connector is 3/4", see chapter 4.8.1 for more details on pipe sizing.
- ▶ Undersized flexible appliance connector not permitted.
- ▶ National Fuel Gas Code requires that a sediment trap (drip leg) be installed on gas appliances not so equipped. The drip leg must be accessible and not subject to freezing conditions. Install in accordance with the recommendations of the serving gas supplier, see fig. 2.

**GAS LINE SIZING**

The gas supply piping for a single heater should be sized for a maximum draw of 175000 BTU/hr for the C950 (Pro TL 175 C) and 199000 BTU/hr for the C 1050 (Pro TL 199 C). Measure the length of gas supply line from the building's gas main to the heater and use the chapter 4.8.1 and 4.8.2, page 42 or the gas line manufacturer's sizing tables to determine the pipe diameter necessary. If there are more gas drawing appliances on the line, size the gas line according to the total maximum amount of BTU draw input rating of for all appliances combined.

**Note:** Undersizing the gas line may result in diminished hot water flow rate and temperature. See chapter 4.14, page 49 for the procedure to measure gas pressure. Proper gas pressure must be confirmed at time of installation.

**<Review>**

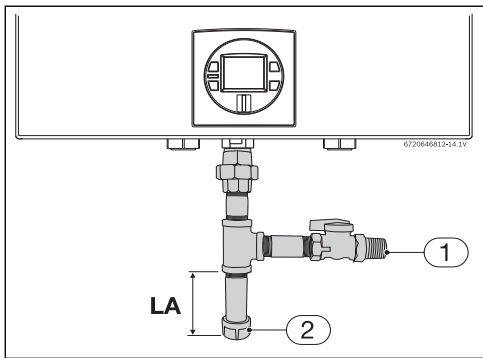

Fig. 34 Gas connection

- [1] Gas supply
- [2] Cap
- [LA] Minimum 3"

Once connections are made, check for gas leaks at all joints. Apply some gas leak detection solution to all gas fittings. Bubbles are a sign of a leak. A combustible gas detector may also be used to detect for leaks.

### 4.8.1 Gas Line Sizing Tables for NATURAL GAS

For your convenience see below for an excerpt from gas line sizing tables for a single NG appliance. For details see the current NFPA 54.

Required input for C 950 (Pro TL 175 C) is 175000 BTU/hr and 199000 BTU/hr for the C 1050 (Pro TL 199 C). The gas supply system must be sized for the combined total maximum BTU/hr load requirements of all gas appliances running simultaneously.

The tables below show the maximum capacity of the gas supply pipe in cubic feet per hour. Please contact your local gas supplier for the energy content of the gas to determine the BTU/hr capacity. Use 1,000 BTU/cubic foot for rough estimations.

Maximum pipe capacity in cubic feet of Natural Gas per hour for gas pressures of 14" W.C. (0.5 psig or 25 mbar) or less and a pressure drop of 0.3" W.C. (0.75mbar) based on 0.60 specific gravity gas).

Nominal Iron Pipe Size, inches	Internal Diameter inches	Length of Black Iron Pipe (Schedule 40 Metallic Pipe), Feet									
		10	20	30	40	50	60	70	80	90	100
3/4	0.824	273	188	151	129	114	104	95	89	83	79
1	1.049	514	353	284	243	215	195	179	167	157	148
1 - 1/4	1.380	1060	726	583	499	442	400	368	343	322	304
1 - 1/2	1.610	1580	1090	873	747	662	600	552	514	482	455

Table 37

Maximum pipe capacity in cubic feet of Natural Gas per hour for gas pressures of <2.0 psig (55" WC or 138 mbar) and a pressure drop of 3.0" W.C. (7.5 mbar) based on 0.60 specific gravity gas).

Nominal Iron Pipe Size, inches	Internal Diameter inches	Minimum Gas Pressure 8.0" WC (20 mbar)									
		Length of Black Iron Pipe (Schedule 40 Metallic Pipe), Feet									
		10	20	30	40	50	60	70	80	90	100
1/2	0.622	454	312	250	214	190	172	158	147	138	131
3/4	0.824	949	652	524	448	397	360	331	308	289	273
1	1.049	1787	1228	986	844	748	678	624	580	544	514

Table 38

Maximum pipe capacity in cubic feet of Natural Gas per hour for gas pressures of 14" W.C. (0.5 psig or 25 mbar) or less and a pressure drop of 0.5" W.C. (1.25mbar) based on 0.60 specific gravity gas).

Tube size, inches	EHD*	Length of Corrugated Stainless Steel Tubing (CSST), Feet									
		10	20	30	40	50	60	70	80	90	100
1	30	330	231	188	162	144	131	121	113	107	101
1	31	383	269	218	188	168	153	141	132	125	118
1 - 1/4	37	639	456	374	325	292	267	248	232	219	208
1 - 1/4	38	746	526	442	386	347	318	295	277	262	249

Table 39

\* EHD = Equivalent Hydraulic Diameter. The greater the value of EHD, the greater the gas capacity of the tubing.

Review

### 4.8.2 Gas Line Sizing Tables for LP GAS

For your convenience see below for an excerpt from gas line sizing tables for a single LP appliance. Their intended use is for pipe sizing between the 2nd stage (low pressure) regulator and the appliance. For details see the current NFPA 54 or NFPA 58.

Required input for C 950 (Pro TL 175 C) is 175000 BTU/hr and 199000 BTU/hr for the C 1050 (Pro TL 199 C). The gas supply system must be sized for the combined total maximum BTU/hr load requirements of all gas appliances running simultaneously.

The tables below show the maximum capacity of the gas supply pipe in thousands of BTU per hour of Undiluted LP Gas at 11" W.C (0.4 psig or 27.4 mbar) based on a pressure drop of 0.5" W.C (1.25 mbar).

Nominal Iron Pipe inches	Internal Diameter inches	Length of Black iron Pipe (Schedule 40 Metallic Pipe), Feet							
		10	20	30	40	50	60	80	100
1/2	0.622	291	200	160	137	122	110	101	94
3/4	0.824	608	418	336	287	255	231	212	197
1	1.049	1150	787	632	541	480	434	400	372

Table 40

Tube size, inches	EHD*	Length of Corrugated Stainless Steel Tubing (CSST), Feet									
		10	20	30	40	50	60	70	80	90	100
3/4	23	254	183	151	131	118	107	99	94	90	85
3/4	23	303	216	177	153	137	126	117	109	102	98
1	30	521	365	297	256	227	207	191	178	169	159
1	31	605	425	344	297	265	241	222	208	197	186

Table 41

\* EHD = Equivalent Hydraulic Diameter. The greater the value of EHD, the greater the gas capacity of the tubing.

Nominal Iron Pipe inches	Internal Diameter inches	Length of Semirigid (soft) Copper ACR Tubing, Feet				
		10	20	30	40	50
5/8	0.527	188	129	104	89	79
3/4	0.652	329	226	182	155	138

Table 42

Maximum Capacity of Semi-Rigid (flexible, non corrugated) Tubing in Thousands of BTU/hr of Undiluted Liquefied Petroleum Gases (at 11 inches Water Column Inlet Pressure). (Based on a Pressure Drop of 0.5 Inch Water Column)\* Source National Fuel Gas Code NFPA 54, ANSI Z223.1 - No Additional Allowance is necessary for an ordinary number of fittings.

<Review>

## 4.9 Water connections

**NOTICE:**

- ▶ This heater is not approved for preheated water applications exceeding 140°F (60°C).

**NOTICE:**

- ▶ In applications where inlet water temperature can exceed 140°F (60°C), a 3-way valve or mixing valve must be installed before the appliance to prevent water exceeding 140°F (60°C) from entering the appliance.
- ▶ When facing the heater, the 3/4" cold connection is on the bottom right and the hot connection is on the bottom left.

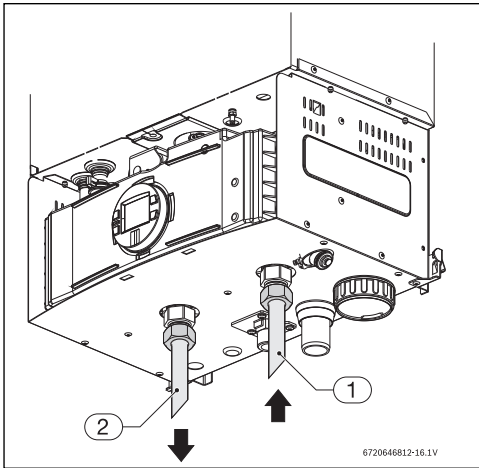

Fig. 35

- [1] Cold connection
- [2] Hot connection

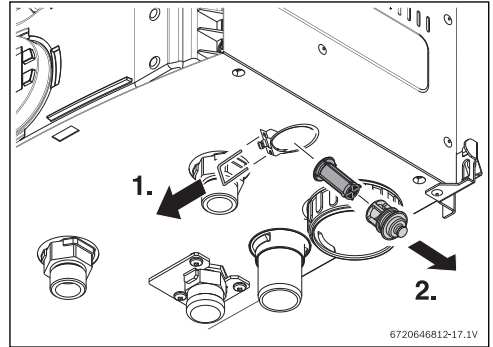

Fig. 36 Water filter

- ▶ The use of unions when connecting both water pipes to the inlet and outlet connections is required. This will facilitate any necessary servicing.
- ▶ Plastic or PEX type plumbing line materials are not suitable for connecting directly to or within an 18" pipe run of the water heater.
- ▶ Although water piping throughout the building may be other than copper, we recommend that copper or suitably rated stainless steel flex line be used for the water connections for 1.5' on either side of the water heater (follow local codes if more stringent).
- ▶ Never sweat any piping directly to or beneath the water connections, as damage will occur to the internal water valve from heating of the pipe.
- ▶ Keep water inlet and outlet pipes to no less than 3/4" (19.05mm) diameter to allow the full flow capacity.
- ▶ If the cold and hot connections to the heater are reversed, the heater will not function. Be certain there are no loose particles or dirt in the piping. Blow out or flush the lines before connecting to the water heater.
- ▶ Full port shutoff valves should be installed on both the cold water supply and hot water outlet lines to facilitate servicing the heater (see fig. 37).
- ▶ For installation on a private well system with the use of a pressure tank, the lowest pressure range setting recommended is 40-60 psi (2.75 - 4.15bar).

**<Review>**

### 4.10 Water quality

Water quality can have an impact on appliance longevity and if water supplied to the Greentherm is not in compliance with table 43 the manufacturer's warranty will be void. For water analysis data call your local water department, or if on a well, have well water analyzed periodically. If water quality exceeds one or more of the values specified below, Bosch recommends consulting a local water treatment professional for water softening/conditioning options.

Description	Max. Levels	
pH	pH	6.5 - 8.5
TDS (total Dissolved Solids)	mg/l or ppm	500
Total hardness	mg/l or ppm	100 (6 grains)
Aluminum	mg/l or ppm	2.0
Chlorides	mg/l or ppm	250
Copper	mg/l or ppm	1.0
Iron	mg/l or ppm	0.3
Manganese	mg/l or ppm	0.05
Zinc	mg/l or ppm	5.0

Table 43

**Connecting the pressure relief valve (PRV)**

A listed pressure relief valve must be installed at the time of installation. No valve is to be placed between the PRV and the heater. No reducing coupling or other restriction may be installed in the discharge line. The discharge line must be a minimum of 4" above a drain and installed such that it allows complete drainage of both the PRV and the line. The discharge line must be placed where it will not cause any damage. The location of the PRV must be readily accessible for servicing or replacement, and be mounted as close to the water heater as possible. See fig. 37. To install the PRV, a suitable fitting connected to an extension on a "T" fitting can be sweated to the hot water line. Support all piping.

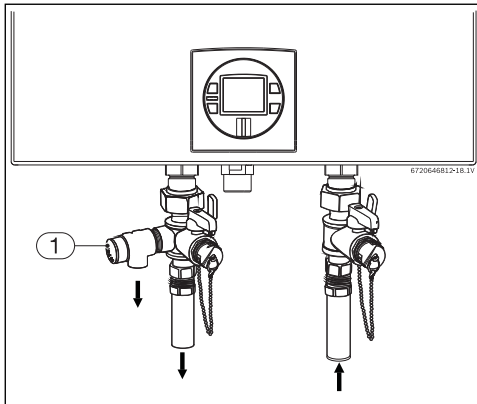

Fig. 37 Plumbing Connections (with shutoff valves) and Pressure Relief Valve

**4.11 Filling the condensate trap**

The condensate trap can be filled before or after connecting the vent pipe.

**Filling the condensate trap before vent pipe installation**

**! DANGER:**

**Flue gas poisoning!**

- ▶ Prior to initial start up, and after appliance has been out of use for a long time or after cleaning the condensate trap, make sure that you fill the condensate trap with water. This is to prevent dangerous exhaust gases from entering the building.
- ▶ Fill the condensate trap by pouring approx. 14 oz. (400ml) of water into the exhaust accessory on the top of the appliance, see fig. 38.

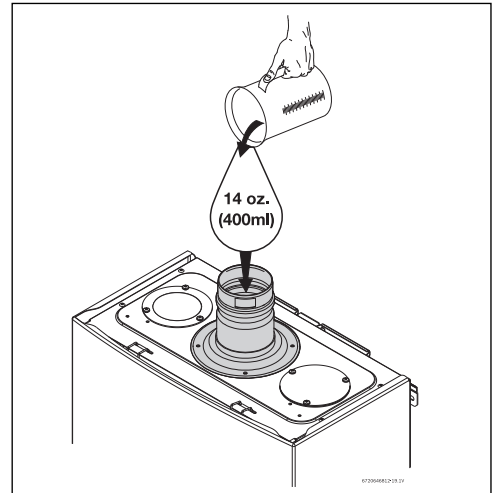

Fig. 38 Filling the condensate trap at start up

**Filling the condensate trap after vent pipe installation**

After appliance has been out of use for a long time or after cleaning siphon, refill the condensate trap with water. Please proceed as follows:

- ▶ Remove front cover, see fig. 4, page 12.
- ▶ Open the four clips and remove the combustion cover, see fig. 5, page 12.

**<Review>**

- ▶ Remove the clip and disconnect the drain tube, see fig. 39.

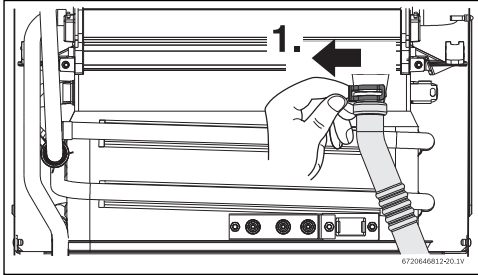

Fig. 39 Disconnect drain tube

- ▶ Fill the condensate trap by pouring approx. 14 oz. (400ml) of water into the top of the drain tube. To avoid damage to the appliance use a funnel in this operation, see fig. 40, page 46.

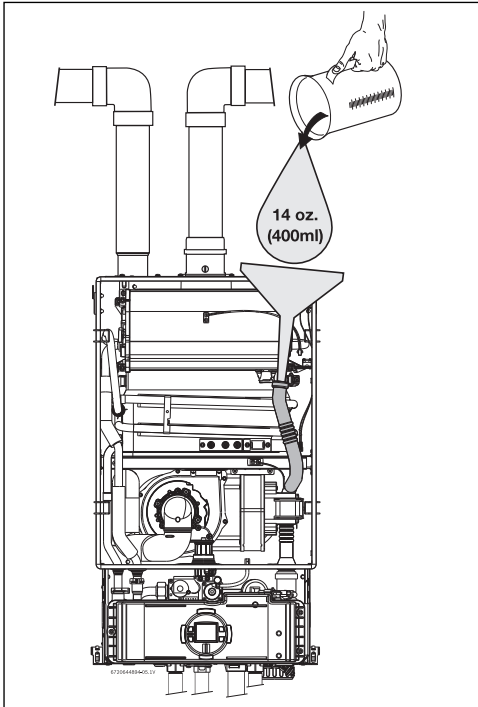

Fig. 40 Filling the condensate trap after installation

- ▶ Loosen the three screws of the control unit.

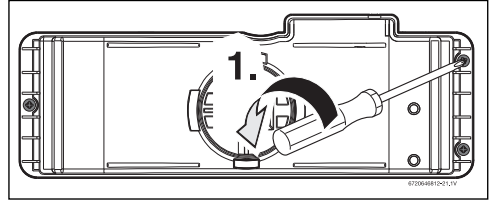

Fig. 41

- ▶ Put the control unit in service position by engaging its tabs with the holes in the bottom horizontal sheet metal, see fig. 42.
- ▶ Check water level in the condensate trap.

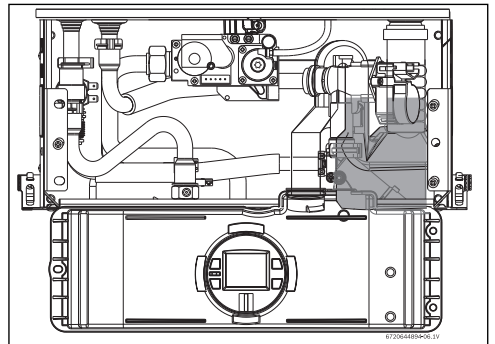

Fig. 42 Water level in condensate trap

- ▶ After filling reassemble all parts in reverse order.

#### 4.12 Domestic hot water recirculation

Although recirculation directly through the tankless water heater is allowed, temperature stability is improved by recirculating through a mini-tank as shown in fig. 43. By using the design in fig. 43, there is no recirculation of hot water through the tankless water heater and therefore, does not affect the heat exchanger warranty. Direct recirculation through the tankless water heater is permissible, however, the heat exchanger warranty is reduced; contact Bosch Thermotechnology for further installation requirements. The following drawing is provided to outline one possible recirculation design using the water heater in conjunction with a Bosch electric mini tank water heater. This schematic is for illustration only and must not be used for actual Installation without appropriate engineering and technical advice from a properly licensed professional in the locality where the installation is made.

**<Review>**

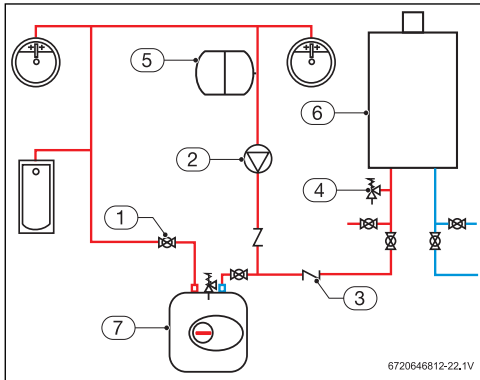

Fig. 43 Recirculation application

- [1] Full port isolation valve
- [2] Circulator pump on timer
- [3] Check valve
- [4] PRV
- [5] Expansion tank
- [6] Greentherm
- [7] Bosch electric minitank

The use of a small electric mini-tank after heater (4-6 gallon size) should be used for this application and designed so the pump will circulate the water through the mini-tank and the building's hot water return loop only. Timed or thermostatically controlled operation of the pump is commonly done. Contact Bosch Thermotechnology if further information is needed.

### 4.13 Space heating applications

**CAUTION:**

- ▶ If the set point temperature is above 120°F, precautions should be taken to protect users of potable water from scalding.

**CAUTION:**

- ▶ Propylene glycol may be used for freeze prevention ONLY on the space heating side of the heat exchanger. Do not use ethylene glycol (automotive antifreeze).

**CAUTION:**

- ▶ The use of a flow switch is recommended to ensure DHW priority and to prevent "cold-blow" situations when the Bosch tankless water heater is used with an air-handling system. The flow switch should be used to disable the blower on the air-handling system when domestic water is used.

**CAUTION:**

- ▶ Ensure the primary pump is properly sized to provide adequate flow for the system heat load.



For Pump sizing please refer to the pressure drop curves, fig. 45. Also remember to account for system piping pressure loss. A minimum of 1.7 GPM is recommended to provide adequate flow through the water heater when determining the size of the primary pump.

Bosch tankless water heaters are approved for use in combination DHW and space heating applications (open-loop setup). These water heaters are not approved for use in space heating only applications (closed-loop setup). Bosch supports applications of combination DHW and space heating in an open loop configuration if plumbed similar to fig. 44. Use of a Bosch tankless water heater in a combination DHW and space heating application will result in the product warranty being reduced to 3 years.

**<Review>**

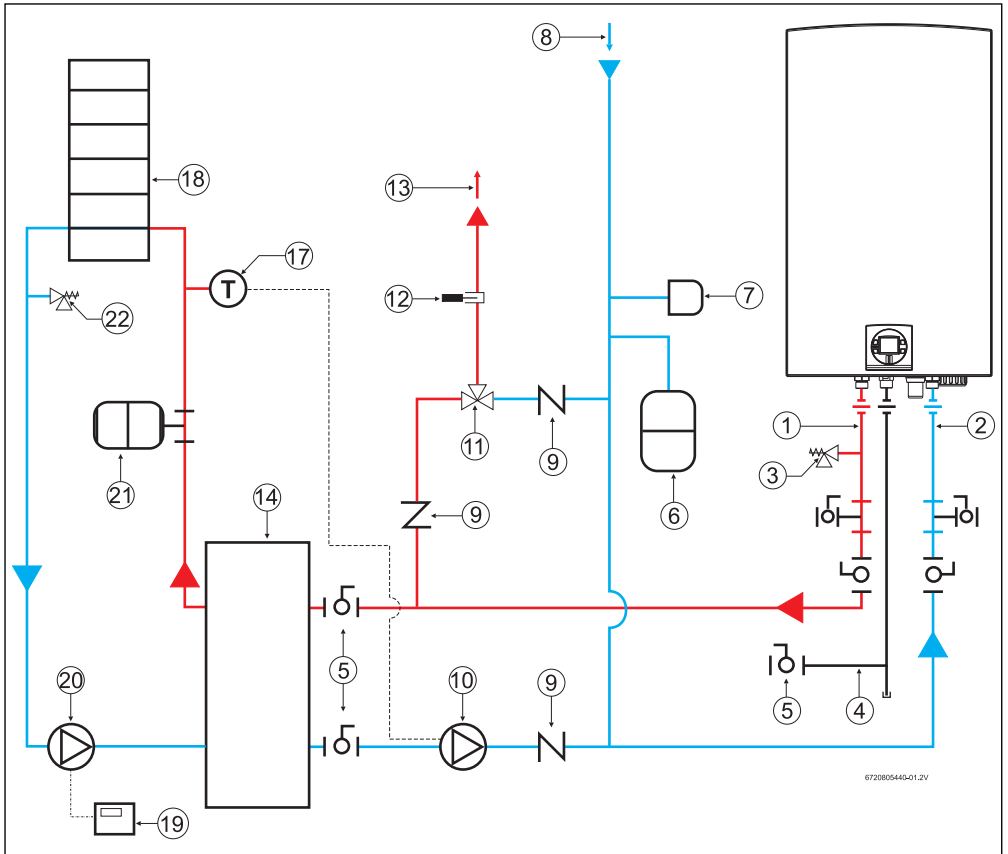

Fig. 44 Space heating diagram

- |                                          |                            |
|------------------------------------------|----------------------------|
| [1] Hot water outlet                     | [18] Space heating pump    |
| [2] Cold water inlet                     | [19] Expansion tank        |
| [3] Pressure relief valve                | [20] Pressure relief valve |
| [4] Gas supply                           |                            |
| [5] Shut off gas valve                   |                            |
| [6] Thermal expansion tank (as required) |                            |
| [7] Atmospheric vacuum breaker           |                            |
| [8] Cold inlet                           |                            |
| [9] Check valve                          |                            |
| [10] Pump                                |                            |
| [11] Thermostatic mixing valve           |                            |
| [12] Thermometer (optional)              |                            |
| [13] DHW outlet                          |                            |
| [14] Water to water heat exchanger       |                            |
| [15] Thermostat                          |                            |
| [16] Space heating zone                  |                            |
| [17] Zone controller                     |                            |

**<Review>**



Fig. 45 Pressure drop curve

#### 4.14 Measuring gas pressure

Confirm gas pressure upon installation.

##### Connecting manometer

- ▶ Shut off gas supply at installer supplied shutoff valve for this water heater.
- ▶ Remove front cover and locate inlet gas pressure test port (see fig. 47).
- ▶ Loosen screw inside left test point fitting (do not remove) and connect manometer tube to test point (see fig. 47).

##### Static Pressure Test

- ▶ Turn gas supply back on.
- ▶ Record static gas pressure reading in table 45.

##### Operating Pressure Test

- ▶ Press ON/OFF button into ON.

- ▶ Press and hold simultaneously buttons , and for 3 seconds, until display reads P2.

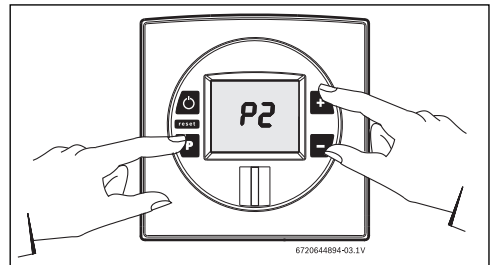

Fig. 46

- ▶ Press to enter P2 adjustment. The current setting will appear on the display (factory default).
- ▶ Press or until P1 appears.

Note: While in this mode the appliance will run constantly at maximum power and allow maximum water flow.

For inlet gas pressure adjustment consider the following table:

Gas type	NG	LPG
P <sub>in</sub>	3.5" WC	8" WC

Table 44 Minimum inlet gas pressure under full operation

- ▶ Operate all other gas appliances (except heater) on same gas piping system at maximum output.
- ▶ Turn on high volume of hot water flow (at least 6 gpm) and burner will light. If heater display reverts to P2, open more hot water fixtures to allow sufficient flow. Press **+** until P1 reappears on the display.
- ▶ Record lowest operating gas pressure reading in table 45.

Gas pressures lower than 3.5" W.C. for Natural Gas or 8" W.C. for LPG will result in insufficient degree rise to the hot water being used, reduced hot water volume, possible error code faults and must be corrected. See Gas Connections, chapter 4.8, page 40.

P1 fan speed:

Factory default: NG: 51, LP: 52

Lowering P1 fan speed reduces the maximum BTU input.

As a temporary measure if the gas pressure in P1 is below specification, lower P1 fan speed incrementally until minimum inlet gas pressure reaches specified range (table 44). After upgrading gas line, reset appliance to P1 factory default setting (NG: 51, LP: 52) or setting from chapter 4.3.8.

<b>Static Gas Pressure Reading (see chapter 4.14)</b>	
enter here: _____	Date: _____
<b>Operating Gas Pressure Reading (see chapter 4.14)</b>	
enter here: _____	Date: _____

Table 45

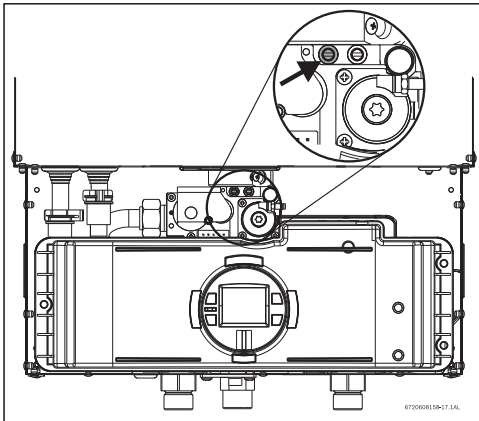

Fig. 47 Gas pressure test port (left tapping)

**<Review>**

## 5 Electrical connections

### 5.1 Electrical power supply



**WARNING:**

- ▶ For safety reasons, disconnect the power supply cord to the heater before any service or testing is performed.



**WARNING:**

- ▶ This heater must be electrically grounded in accordance with the most recent edition of the National Electrical Code, NFPA 70. In Canada, all electrical wiring to the heater must be in accordance with local codes and the Canadian Electrical Code, CSA C22.1 Part 1. Do not rely on the gas or water piping to ground the metal parts of the heater.

The water heater requires an electrical power supply from a 120VAC / 60Hz properly rated receptacle and must be properly grounded.

The heater is wired as shown in the wiring diagram (chapter 10, fig. 76).

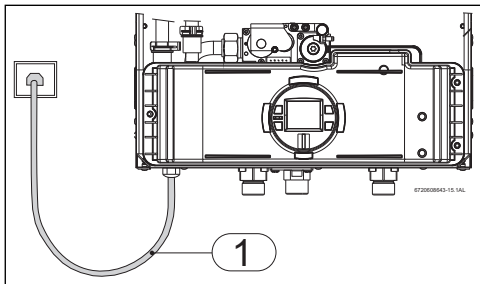

Fig. 48 Connecting power supply cord

[1] Power cord length: 3ft.

Note: The outlet the appliance is plugged into should be clear from possible water damage.

### 5.2 Position of the fuses in control unit

To check fuses, proceed as follows:

- ▶ Remove the front cover, see fig. 4, page 12.

- ▶ Remove the three screws from the control unit.

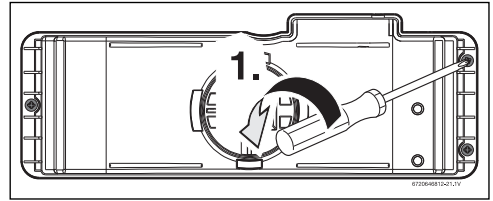

Fig. 49

- ▶ Remove the six screws from the back cover of the control unit, see fig. 50, pos. 2.
- ▶ Check the fuses in the printed circuit board, see fig. 50, pos. 3.

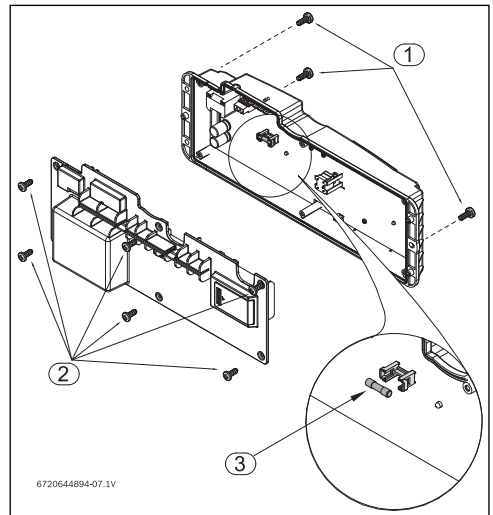

Fig. 50 Fuses position

- ▶ After checking the fuses, reinstall all parts in reverse order.

## 6 Operation instructions

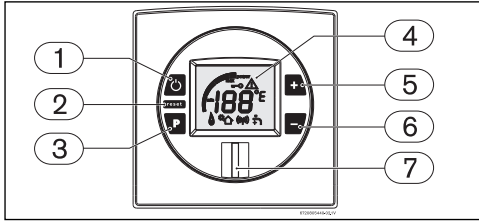

Fig. 51

- [1] On/Off button
- [2] Reset button
- [3] Program Key
- [4] LCD display
- [5] Up button
- [6] Down button
- [7] Power On or stand-by LED

### 6.1 Description LCD Display

**NOTICE:**

- ▶ Do not use any aggressive or corrosive cleaning agents to clean the window.

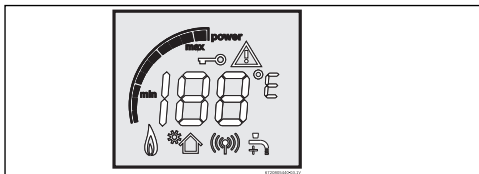

Fig. 52 Power bar indicator (input)

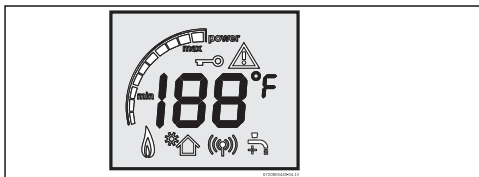

Fig. 53 Temperature indicator

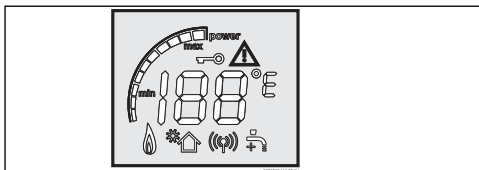

Fig. 54 Error indicator

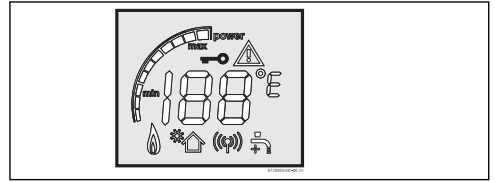

Fig. 55 Locked condition indicator (only with remote control)

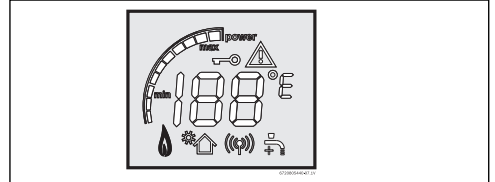

Fig. 56 Flame indicator

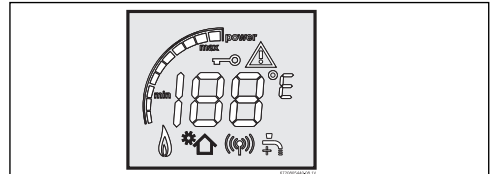

Fig. 57 Solar mode indicator (see chapter 6.4, page 53)

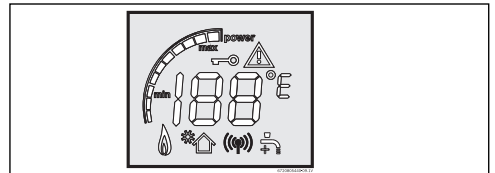

Fig. 58 Remote control indicator

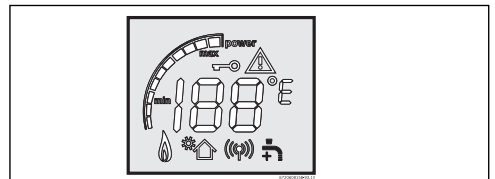

Fig. 59 Activation water flow (see chapter 12)

<Review>

## 6.2 For your safety read before operating your water heater



### WARNING:

#### Explosion hazard!

- ▶ If you do not follow these instructions exactly, a fire or explosion may result causing property damage, personal injury or loss of life.

**A.** This appliance is equipped with electronic ignition for lighting the main burner. When turning the heater on, follow these instructions exactly.

#### WHAT TO DO IF YOU SMELL GAS

- ▶ Turn off the gas shut-off valve.
- ▶ Open windows and doors.
- ▶ Do not try to light the appliance.
- ▶ Do not touch any electrical switch, telephone, and do not use outlets.
- ▶ Extinguish all open flames. Do not smoke! Do not use lighters!
- ▶ Warn all occupants of the building. Do not ring doorbells!
- ▶ If you can hear gas leaking, leave the building immediately.
- ▶ Prevent others from entering the building and notify the police and fire department from outside the building.
- ▶ From outside the building, call the gas utility company and a trained and certified installer.

**B.** Use only your hand to press the on/off control switch. Never use tools. If control switch is jammed, close the gas supply and call a qualified service technician. Forceful repair may result in a fire or explosion.

**C.** Do not use this appliance if any part has been under water. Immediately call a qualified service technician to inspect the appliance and to replace any part of the control system and any gas control which has been under water.

## 6.3 Power

### On

- ▶ To start the appliance press the On/Off button.

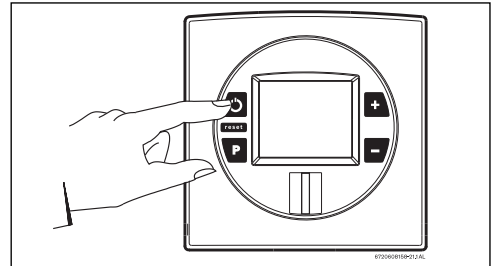

Fig. 60

### Off

- ▶ To shut down the appliance press the On/Off button again.

## 6.4 Temperature selection

To select hot water temperature:

- ▶ Press buttons **+** or **-** in order to reach desired temperature.

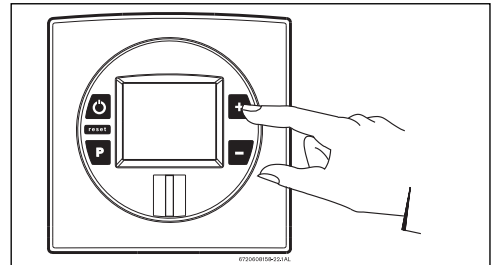

Fig. 61

### Setting the water temperature

The desired temperature of the hot water can be adjusted on the front control panel of the heater.

The water heater has an electronically controlled gas valve that modulates the burner input in response to both varying hot water flow rates and/or changes in any incoming and outgoing water temperatures.

**Note:** The water heater, running at minimum BTU, may still achieve temperatures above the desired set temperature. Low flowing fixtures are the leading cause of this type of temperature overshoot. To combat this symptom, clean fixtures or replace with higher flowing ones if necessary.

**Saving water resources:**

- ▶ Make sure you close all the taps after any use. Avoid leaving the taps dripping. Repair any leaking tap.
- ▶ Define the temperature you want, in the appliance or with the remote control. This way you have the precise water flow needed (mixing cold water to regulate temperature will increase the water flow with consequent waste of water).

The water heater will not ignite if inlet water temperature exceeds the set point temperature less 9 °F (5 °C). In this condition, the solar mode indicator will show on the LCD display. See fig. 57, page 52.

Solar mode activation formula	Example:
Temp. inlet > Temp. set - 9°F (5 °C)	104 °F (40 °C) > 112 °F (44 °C) - 9°F (5 °C)

Table 46

**NOTICE:**

**Appliance damage!**

- ▶ In applications where inlet water temperature can exceed 140°F (60°C), a thermostatic or mixing valve must be installed before the appliance to prevent water exceeding 140°F (60°C) from entering the appliance.

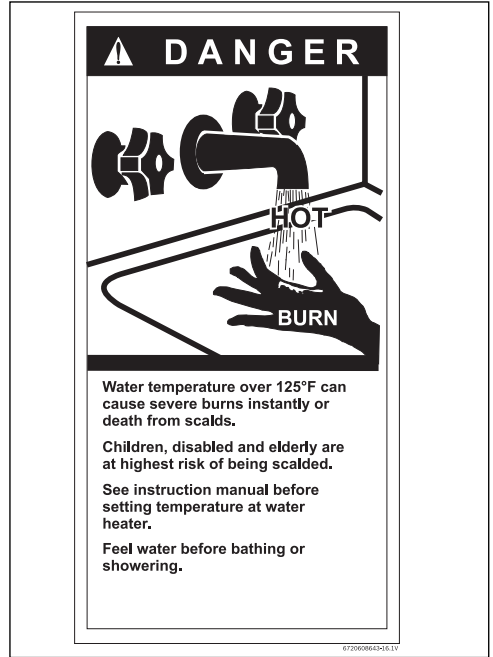

Fig. 62

**6.5 Use of optional remote control accessory (part no. 7709003213)**

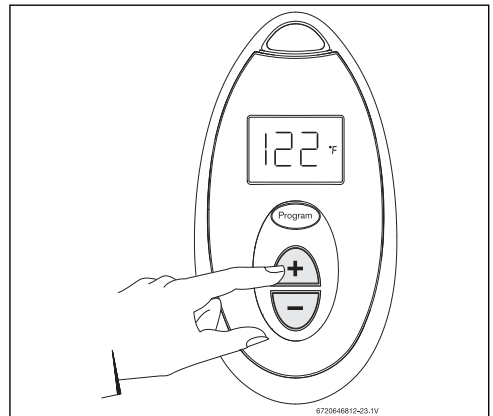

Fig. 63 Remote control

The wireless remote control accessory (fig. 87, component 13) and the temperature selector buttons on the front of the water heater operate identically. Contact your distributor to order the remote control accessory. Modification of the water

**<Review>**

heaters interior control unit (fig. 87, component 16) is required when installing the remote control with this heater.



NOTE: up to 6 remote controls can be programmed for one single water heater, each with a range distance of 98 ft (30 m).

### 6.6 Operation

- ▶ When a hot water tap is opened, main burner ignites and LCD displays indication .

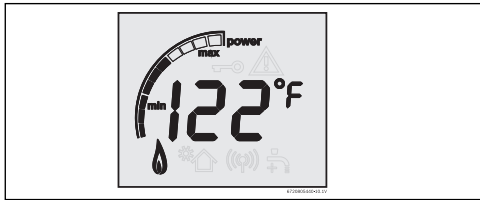



Fig. 64

- ▶ LCD flashes until selected temperature is reached.
- ▶ Power bar indicates power percentage in use.

### 6.7 Reset button

If the LCD shows the error symbol  do not shut off power or unplug the heater. Follow instructions below to reset error first. Record the error code on LCD and consult "Problem solving" chapter 9.1, page 66.

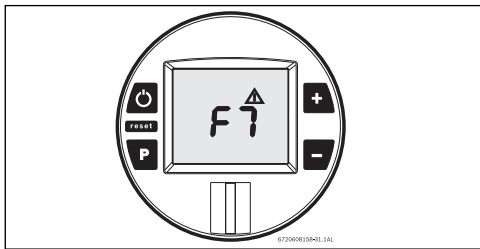

Fig. 65

After following instructions indicated in "Troubleshooting" section,

- ▶ press reset button firmly in order to return heater to normal operation.

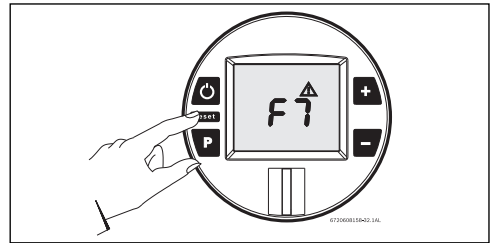

Fig. 66 Reset button

If the problem persists, contact your installer.

### 6.8 Program button

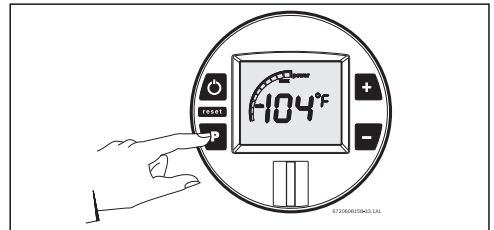



Fig. 67 "Program" key

#### 6.8.1 Memorizing selected temperature

- ▶ Press buttons  or  to select desired temperature.
- ▶ Hold "Program" button for 3 seconds to save temperature.

When LCD stops blinking, temperature is saved in memory.

#### Using "Program" function

In order to select memorized temperature

- ▶ Press "Program" key.

LCD shows pre-memorized temperature, which is now the hot water selected temperature.

### 6.9 Locked condition

This condition is only valid for appliances with one or more remote controls installed.

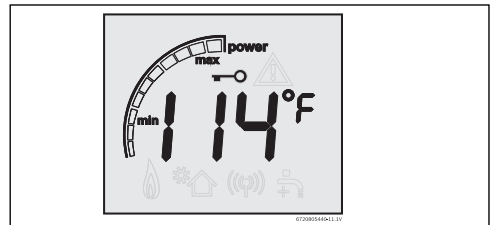



Fig. 68 Locked condition

Whenever LCD shows , the temperature setting cannot be adjusted because the appliance is in use by a user which already selected a different temperature. Appliance will be automatically unlock 5 minutes after closing hot water tap.

## 7 Maintenance and service



### DANGER:

- ▶ Always shut off the electrical power supply, shut off the manual gas valve and shut off the water valves whenever servicing.

### NOTICE:

- ▶ Inspect and clean the complete water heating system once a year.
- ▶ Carry out maintenance as required. Immediately repair all faults to avoid damage to the system.

#### Annual maintenance table

		Every year
1.	Inspect venting system	X
2.	Inspect combustion chamber	X
3.	Inspect burner	X
4.	Inspect pressure relief	X
5.	Inspect water filter	X
6.	Inspect Heat Exchanger	X
	Descaling Fin Coils	
7.	Inspect condensate trap	X

Table 47 Annual maintenance

### 7.1 Annual maintenance

(To remove front cover, see page 12.)

#### Venting System

- Venting system - inspect inside of flue pipe for any blockage or restriction. Observe burner flames during heater operation. (front cover must be removed). Burner flames should be steady and blue. Yellow, inconsistent (bouncing) flames may be an indication of poor ventilation or combustion air supply. Inspect the combustion air inlet

pipe for blockage or debris. Inspect combustion air and exhaust terminations for blockage or debris.

#### Combustion Chamber

- Inspect burner observation window (fig. 80, #14) for cracks or spillage of flue gases. Observe burner flames during heater operation. Flames should be steady and blue with no signs of yellowing. Yellow burner flames are an indication of improper combustion. Refer to chapter 4.4, page 38, chapter 4.3, page 15 of this manual to verify exhaust system and combustion air supply meets manufacturer's specifications.

#### Pressure Relief

- Manually open the pressure relief valve to ensure proper operation.

#### Inlet Water Filter

- Verify the inlet filter screen is clean and undamaged. The inlet water filter is located on the bottom of the appliance, to the right of the cold water inlet fitting. (See fig. 36, page 44). Close installer supplied water shutoff and remove wireform spring clip from filter. Remove filter, clean and or replace if damaged.

#### Descaling

- In areas where the water supply has a high mineral content, the heat exchanger should be flushed with a descaling solution. Scale build up will shorten the life of the water heater and damage resulting from scale is not covered under warranty. Refer to chapter 7.3 for detailed instructions on descaling the heat exchanger.

#### Fin Coils

- Inspect heat exchanger fin coils for soot build-up or blockage. To access fincoil, consult service bulletin at [www.boschheatingandcooling.com](http://www.boschheatingandcooling.com). If there is evidence of soot build-up or blockage, the heat exchanger should be removed by a professional and cleaned thoroughly. Soot is in indication of incomplete combustion and a clear sign of a serious problem. Venting, gas pressure and flue gases should be examined to determine the cause of the problem. Damage to the water heater caused by incorrect installation or adjustment are not covered by the manufacturer's warranty.

#### Condensate trap

- Check water level in the condensate trap, see fig. 38.
- If appliance is out of service for more than 10 days, fill as described on page 46.
- Check for debris and clean if needed.

Review

## 7.2 Winterizing for seasonal use

The water heater must not be installed in a location where it may be exposed to freezing temperatures. If the heater must be left in a space which is likely to experience freezing temperatures, all water must be drained from the heater. If precautions are not taken, resulting damage will not be covered under the warranty. NOTE: Use of agents such as anti-freeze is not permitted and voids the warranty, as they may cause damage to the water heater's internal components.

1. Press ON/OFF switch on the water heater to turn OFF the heater and unplug power supply cord. The display should be blank.
2. Shut off gas supply to heater.
3. Shut off the water supply to the water heater using installer supplied shutoff valve.
4. Open hot water taps to drain and relieve pressure from the plumbing system. If water continues to flow after 5 minutes, a crossover of the hot and cold water pipes is present and must be corrected before proceeding.
5. Disconnect inlet and outlet water pipes from the water heater. Place a small bucket underneath the water heater to catch residual water remaining inside the water heater.
6. Using an air compressor, blow short bursts of air (100psi max) through the inlet water connection until there is no water present coming through the outlet water connection of the heater.
7. Reconnect water fittings and return heater to service when danger of freezing has passed.
8. Empty condensate trap.

## 7.3 Mineral scale build-up

Periodic descaling may be necessary in areas with high mineral content in the water. Scale buildup in the heat exchanger may result in lower flow rates, error codes of A7 and E9 and boiling sounds in the heat exchanger.

A water softener is required if the water hardness exceeds 6 grains/gal (103 mg/l) calcium carbonate. Damage to the water heater resulting from hard water/scale deposits will not be covered under warranty.

### Descaling using a pump

- ▶ Disconnect electrical supply from the water heater.
- ▶ Shut off the water supply to the water heater using (installer supplied) shutoff valve.
- ▶ Open hot water taps to drain and relieve pressure from the plumbing system.
- ▶ Drain water from the unit's heat exchanger by disconnecting inlet and outlet water connections from the heater.

- ▶ Connect a line (A) from the outlet of the circulating pump (installer supplied) to the inlet water fitting on the water heater (see fig. 69).
- ▶ Using another line (B), connect the water outlet fitting on the water heater. Route the other end of this line into a descaling reservoir.
- ▶ Using a 3rd line (C) from the descaling reservoir, connect to the inlet side of circulating pump. Install a filter on the end of the line in the descaling reservoir.
- ▶ Make sure all connections are "water tight".
- ▶ Fill tank with descaling solution so both lines inside are submersed. We recommend a straight white vinegar solution. If using a commercial descalant, refer to manufacturer's instructions for proper dilution ratio.
- ▶ Operate the circulating pump.
- ▶ Make sure there are no leaks and the solution is flowing from the descaling reservoir through the heater and returning to the reservoir.
- ▶ Run solution through the heater until the solution returning to the descaling reservoir comes out clear. (Changing to a fresh solution may be necessary during this process).
- ▶ Disconnect all lines and drain all solution from heat exchanger. Properly discard of solution.
- ▶ Position a container below the hot water outlet and connect cold water supply. Open cold water supply shutoff valve and flush heat exchanger with clean water.
- ▶ Shut cold water shutoff valve and reconnect hot water supply to the water heater.

- ▶ Reconnect electrical supply to unit, open water shutoff valves, and return the unit to service.

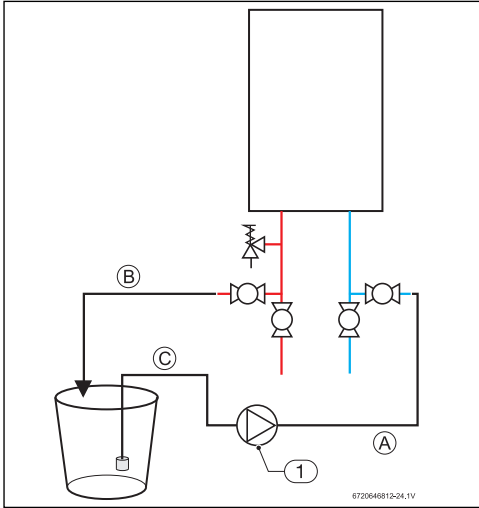

Fig. 69

[1] Pump

### 7.4 Condensing heat exchanger unit

The condensing heat exchanger unit must be checked once a year by a qualified and trained technician. If repairs are needed, the repairs should be done by a certified Bosch technician. Commercial or recirculating applications may require more frequent condensing heat exchanger service.

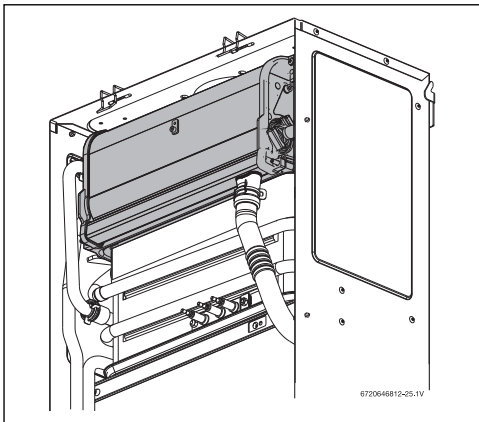

Fig. 70 Condensing heat exchanger unit

Condensing heat exchanger unit maintenance;

- ▶ Shut off power. Disconnect power cord.

- ▶ Dismantle all inlet, outlet pipes and the condensate tube from the condensing heat exchanger unit.
- ▶ Remove the condensing heat exchanger unit from the appliance by pulling it towards you.
- ▶ Examine the fin tubes visible through the back ports of the heat exchanger. If there are significant deposits, flush out with warm water. If obstruction remains or damage to the fins is visible, dismantle the heat exchanger for further examination and repair.
- ▶ Dismantle all parts for inspection and cleaning.



NOTE: A condensing heat exchanger gasket and o-ring kit is necessary for this step.

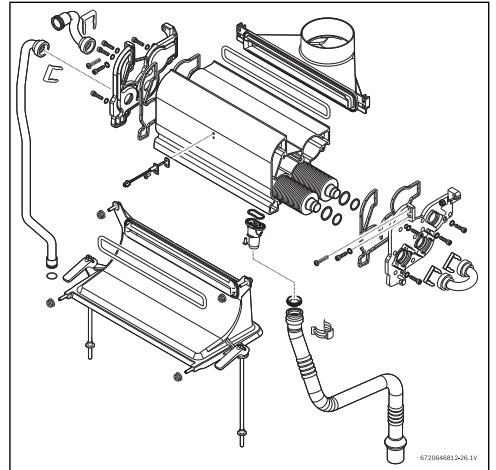

Fig. 71 Condensing heat exchanger

- ▶ Clean fins with warm water and a stiff brush. If fin damage is found replace damaged fin tube.



It is important to inspect and properly replace the gaskets and o-rings.

- ▶ Assemble the condensate unit and all other parts in reverse order of disassembly.

**<Review>**

### 7.5 Adjusting CO<sub>2</sub>

The CO<sub>2</sub> can only be adjusted by a certified gas technician with a calibrated CO<sub>2</sub> analyzer.



CO<sub>2</sub> adjustment is required in Natural Gas installations where energy content is less than 900 BTU/cuft, and in installations with repeated unresolved EA and EC errors (ref. to page 66 "Problem solving").



**CAUTION:**

- ▶ One factor that may affect CO<sub>2</sub> levels is improper gas pressure. Please see chapter 4.14 for the procedure to measure gas pressure and record your findings below:

Static Gas Pressure:  " WC

P1 Operating Pressure:  " WC

The P1 minimum operating gas pressure is 3.5" WC for Natural Gas and 8" WC for Propane. Do not proceed in adjusting CO<sub>2</sub> until pressure is at or above these levels, but not to exceed 10.5" WC for Natural Gas and 13" WC for Propane.

**A. Once Gas Pressure is adequate**

- ▶ Press ON/OFF button to turn OFF the heater.
- ▶ Remove brass flat head screw on the exhaust collar as seen in fig. 72.
- ▶ Insert CO<sub>2</sub> analyzer probe into the measuring port. The tip of the probe should be in the center of the flue pipe (approx 1.5" inserted). Avoid air gaps between probe and measuring port as they can alter readings.

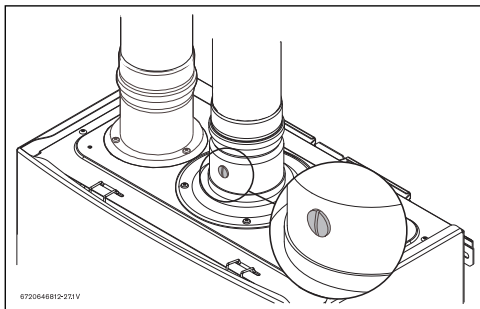

Fig. 72 Measuring port

- ▶ Press the ON/OFF button to turn ON the heater.

- ▶ Press and hold simultaneously buttons **+**, **-** and **P** for 3 seconds, until display reads P2.

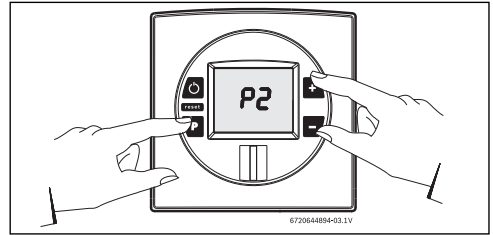

Fig. 73

- ▶ Press **-** button until "P1" appears on display.

**B. Measuring CO<sub>2</sub> (Combustion cover Installed):**

- ▶ Open all hot water taps to achieve a flow rate of at least 6 gallons per minute. (1 tub and 2 sinks should be sufficient). If heater display reverts back to P2, open more hot water fixtures to allow sufficient flow. Press + until P1 reappears on the display.
- ▶ Record the CO<sub>2</sub> reading in P1 below. (Analyzer reading may take several minutes to stabilize).
- ▶ Press the '+' button until P2 appears. Unit will ramp down to low fire and the water flow should decrease.
- ▶ Record the CO<sub>2</sub> reading in P2 below.

P1 CO<sub>2</sub> Reading:  % CO<sub>2</sub>

P2 CO<sub>2</sub> Reading:  % CO<sub>2</sub>

Note: When making adjustments, make sure combustion cover is installed.

		CO <sub>2</sub> range (%)		Max. CO level (measured)
		C 950ES (Pro TL 175 C)	C 1050ES (Pro TL 199 C)	
		Nat. Gas	Nat. Gas	
max. input	P1	7.2% - 7.8%	7.8% - 8.4%	< 250 ppm
min. input	P2	1.5% - 1.8%	1.5% - 1.8%	< 60 ppm
		LP Gas	LP Gas	
max. input	P1	8.8% - 9.4%	9.5% - 10.1%	< 250 ppm
min. input	P2	1.9% - 2.2%	1.9% - 2.2%	< 60 ppm

**\* Values above are for climate controlled conditions. Inputs such as gas pressure, heating value of the gas, humidity and temperature of combustion air all impact CO and CO<sub>2</sub> values. Changes in these inputs can result in different CO and CO<sub>2</sub> values on the same appliance.**

Table 48 CO & CO<sub>2</sub> target numbers

**<Review>**

**C. Adjusting CO<sub>2</sub>:**

**Note: P1 adjustment will change the P2 reading. Confirm the P1 value BEFORE adjusting the P2 level.**

1. If P1 CO<sub>2</sub> level is off:
  - ▶ Loosen yellow painted Phillips screw (1) and cover should rotate down (2) revealing a recessed brass slotted screw. (fig. 74).
  - ▶ Turning the slotted screw counter clockwise will raise P1 CO<sub>2</sub> levels and clockwise will lower P1 CO<sub>2</sub> levels. Adjustments to the slotted screw will also change P2 CO<sub>2</sub> levels.
  - ▶ After bringing the P1 CO<sub>2</sub> readings in proper range, press the **+** button to enter the P2 mode. Verify CO<sub>2</sub> readings in P2 mode.

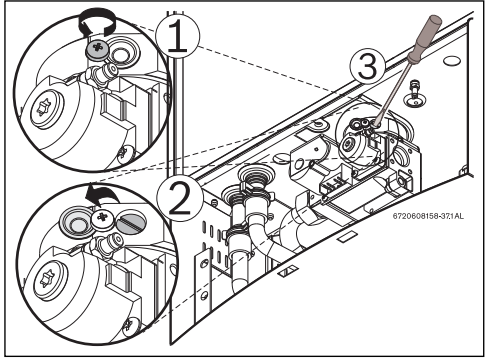

Fig. 74 Adjusting P1 CO<sub>2</sub> level

2. If P2 CO<sub>2</sub> level is off:
  - ▶ Remove yellow painted #40 Torx cover from the front of the gas valve. (fig. 75) A plastic #40 Torx screw will be revealed.
  - ▶ Turning the plastic #40 Torx screw counter clockwise will lower P2 CO<sub>2</sub> levels and clockwise will raise P2 CO<sub>2</sub> levels.

**Note:** This screw adjustment is very sensitive and should be made in small increments. It may take several minutes for readings to stabilize.

3. Verify both P1 and P2 CO<sub>2</sub> readings are within the ranges specified in table 48. Repeat steps 1 and 2 as necessary until CO<sub>2</sub> values are within the specified ranges.

**Final Readings**

P1 CO<sub>2</sub> Reading:  % CO<sub>2</sub>

P2 CO<sub>2</sub> Reading:  % CO<sub>2</sub>

**D. Returning to Service:**

1. Return slotted screw cover to original position.
2. Reinstall Torx cover.
3. Remove CO<sub>2</sub> analyzer probe and reinstall flathead screw with gasket in exhaust collar.
4. Press ON/OFF button to turn OFF the heater and then turn ON the heater.
5. Heater is ready for normal operation.

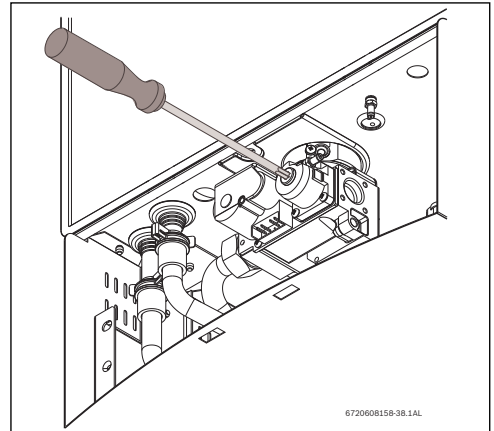

Fig. 75 Adjusting P2 CO<sub>2</sub> level

**<Review>**

## 7.6 Program values

This section describes details on programming the appliance.

For most applications the factory default values will provide robust and stable operation. Only adjust the factory settings if the installation requires changes as indicated in the appropriate section of this manual.

Refer to chapter 7.7 Control board diagnostics (page 62) regarding how to access these P-modes.

### NOTICE:

#### Appliance malfunction!

- ▶ Misadjusted program values can lead to appliance malfunction, errors, and service calls.

Program	Description	Factory Default		MIN C 950ES / C1050ES (Pro TL 175/199 C)	MAX		Comment
		C 950ES (Pro TL 175 C)	C 1050ES (Pro TL 199 C)		C 950ES (Pro TL 175 C)	C 1050ES (Pro TL 199 C)	
<b>P1</b>	Maximum Power	NG: 46, LP: 46	NG: 51, LP: 52	21	NG: 48, LP: 48	NG: 53, LP: 53	see chapter 4.14, page 49 note: reducing P1 values below maximum will reduce maximum power of the appliance.
<b>P2</b>	Minimum Power	NG: 10, LP: 13		NG: 8, LP: 11	20		see chapter 4.3.8, page 32
<b>P3</b>	Remote Controls installed	_0		_0	6		see chapter 6.5, page 54
<b>P4</b>	Access to Diagnostic Mode	E		0d	10f		see chapter 7.7, page 62
<b>P5</b>	Cascade Mode	NO		NO	CC		contact Bosch for details
<b>P6</b>	Temperature Unit	°F		°F	°C		
<b>P7</b>	Gas type selection	LP or NG					Preset from factory. Contact Bosch for details.
<b>P8</b>	Back light	Not Available	dE	dE	Not Available	On	dE turns back light off after 60 seconds from last button pushed, ON turns backlight on permanently.
<b>P9</b>	Fan Purge						Runs secondary fan and primary fan when P9 is selected by depressing the "P" - button.
<b>PH</b>	Cascading type	IC		IC	SC		This menu is only available when cascade mode is selected CC.
<b>PC</b>	Primary/ Secondary mode	CS		CS	Cn		Contact Bosch Water Heating for details.

Table 49 Program values, factory default settings and ranges.

### 7.7 Control board diagnostics

1. Press ON/OFF button into ON.
2. Press and hold simultaneously buttons , and for 3 seconds, until display reads P2.
3. Press to enter P2 adjustment. The current setting will appear on the display. If not, repeat process.
4. Press and release the button on the control panel until the display reads 'P4'. You are now in the diagnostic mode of the control board.
5. When the display reads 'P4', press and release the button once again and the display should read 'E'.
6. Use the and button on the control board to cycle through different diagnostic modes available.
7. Once in the selected diagnostic mode of your choice, press and release the button to display the diagnostic information.

EXAMPLE: to read the flow rate in gallons per minute while the unit is flowing water, cycle to the '3d' mode and press the button. A reading of 25 on the display would indicate the heater is reading a flow rate of 2.5 gallons/minute.

8. Once the information is obtained, press the button again to return to the diagnostic mode menu and scroll to addition diagnostic information.
9. Press ON/OFF button to turn OFF the appliance and back ON again to return heater to normal function.

Diagnostic menu	
<b>E</b>	Entry/Exit into sub-modes
<b>0d</b>	Heat exchanger water temperature
<b>1d</b>	Inlet water temperature (°F)
<b>2d</b>	Outlet water temperature (°F)
<b>3d</b>	Water flow (gallons/min)
<b>4d</b>	Bypass control monitor (°F) [0d - 2d]
<b>5d</b>	Fan speed (Hz)
<b>6d</b>	Burner power (%)
<b>7d</b>	Maximum power (kW)
<b>8d</b>	Back flow temperature (°C)
<b>9d</b>	Exhaust temperature (°C)
<b>1F</b>	Most recent error/failure
<b>2F</b>	2nd most recent error
<b>3F</b>	3rd most recent error
<b>4F</b>	4th most recent error
<b>5F</b>	5th most recent error
<b>6F</b>	6th most recent error
<b>7F</b>	7th most recent error
<b>8F</b>	8th most recent error
<b>9F</b>	9th most recent error

Diagnostic menu	
<b>10F</b>	10th most recent error
<b>1P*</b>	Appliance type - Cd (Condensing) Appliance type - nC (Non condensing)
<b>2P*</b>	Appliance power - 175 / 199 (kBTU/hr)
<b>3P*</b>	Temperature range - H (100-140°F) Temperature range - C (100-184°F)
<b>H0</b>	Numbers of hours - mode 0
<b>H1</b>	Numbers of hours - mode 1
<b>H2</b>	Numbers of hours - mode 2
<b>C0</b>	Number of cycles - mode 0
<b>C1</b>	Number of cycles - mode 1
<b>C2</b>	Number of cycles - mode 2

Table 50 \*Settings define from factory

#### 7.7.1 Working hours

To see how many hours the appliance has worked, please enter the "Diagnostic menu" (chapter 7.7);

- ▶ Select the sub-mode "H0".  
Write the number that shows in the display.
- ▶ Select the sub-mode "H1".  
Write the number that shows in the display.
- ▶ Select the sub-mode "H2".  
Write the number that shows in the display.

After checking the sub-modes H0, H1 and H2, introduce the values in the table below;

Working hours		
Number in H0	_____	_____ +
Number in H1	_____ (X 100) =	_____ +
Number in H2	_____ (X 10 000) =	_____
(H0 + H1 + H2) = Total of hours		_____

Table 51

#### Example:

Calculation of number of working hours,

Working hours		
Number in H0	60	60 +
Number in H1	5 (X 100) =	500 +
Number in H2	0 (X 10 000) =	0
(H0 + H1 + H2) = Total of hours		560

Table 52

Review

**7.7.2 Number of cycles**

To see how many cycles the appliance has done, please enter the “Diagnostic menu” (chapter 7.7);

- ▶ Select the sub-mode “C0”.  
Write the number that shows in the display.
- ▶ Select the sub-mode “C1”.  
Write the number that shows in the display.
- ▶ Select the sub-mode “C2”.  
Write the number that shows in the display.

After checking the sub-modes C0, C1 and C2, introduce the values in a table as the example;

**Example:**

Calculation of number of cycles (1 cycle = 1 ignition),

Number of cycles		
Number in C0	40	40 +
Number in C1	6 (X 100) =	600 +
Number in C2	1 (X 10 000) =	10 000
(C0 + C1 + C2) = Total of cycles		10 640

Table 53

**<Review>**

**8 Troubleshooting**

 **CAUTION:**

- ▶ If you are unable to perform the tasks listed below, or need additional assistance please contact a qualified gas technician.

**8.1 Introduction**

Many of the questions customers ask regarding operation of this unit can be answered by following the troubleshooting steps as outlined below. Visit our web site at [www.boschheatingandcooling.com](http://www.boschheatingandcooling.com) for more detailed troubleshooting. For best results, perform each step before proceeding to the next. The suggested solutions may require that the cover be taken off. (See fig. 3, page 12).

**8.2 Burner does not ignite when hot water is turned ON**

It is recommended to use “Control board diagnostics” page 62, chapter 7.7 as a tool for problem solving. If the display is showing a blinking two digit code, refer to this section.

1. If the display is blank, verify power to outlet. (120VAC/ 60Hz properly grounded circuit required). Verify that the heater power button is pressed ON.
2. Verify the fuses in the control board are good. To access fuses, the control board must be removed. See chapter 5.2, page 51.
3. Make sure cold water inlet connection is plumbed to the right side of heater when facing unit. See fig. 35, page 44.
4. A minimum of 0.5 gallons per minute (1.9 l/m) of hot water demand is required to activate the heater. Confirm at least 0.5 gpm flow by timing how long it takes to fill a container. A quart container should fill in 23 seconds or less, from hot water tap only, to activate heater. In unusual circumstances with high inlet water temperatures and low set temperatures, the heater may increase the activation rate above 0.5 gpm to avoid overheating at low flows. Gradually increase water flow (hot water demand) through the heater to determine if the heater activates with higher flow.
5. Clean inlet filter screen per chapter 4.9, page 44.
6. Inspect the water path for obstructions. Make sure all shower heads, faucet aerators and whole house filters are clear of debris.
7. Check for plumbing crossover. A crossover in the hot and cold plumbing pipes creates back pressure on the water flowing through the heater. Therefore, a higher flow rate than normal is needed to force the heater to activate. To check for a plumbing crossover, shut off the cold water

supply to the water heater. Then open all of the hot water taps served by the heater. Wait 10 minutes and check for water flow at each tap. There should be no water flowing. Any continuous flow of water, small or large, indicates a crossover is present and must be corrected. Consult a professional plumber for help in correcting a crossover. Failing single lever faucet mixing valves are common causes of plumbing crossovers.

8. With the power button pressed switch turned to OFF and the power supply cord unplugged, remove the unit's front cover (See fig. 3, page 12). Check wire connections between the water valve, control unit and electrode set. See chapter 13.2, page 76 for location of these parts.
9. Water heater in solar mode. If inlet water temperatures exceed the water heater's set temperature, the burners will not ignite and the solar mode indicator will show on the display. See page 57, page 52.

### 8.3 Water is too hot

1. Selected temperature on the unit is too high. To lower output temperature, see chapter 6.4, page 53.
2. Clean inlet filter screen per chapter 7.1, page 56 to increase flow through the heater.
3. Inspect the water path for obstructions. Make sure all shower heads, faucet aerators and whole house filters are clear of debris.
4. Confirm the heater's gas type coincides with the type of gas being supplied. See fig. 2, page 11 for location of rating plate.
5. Avoid restrictive outlets. Clean all shower heads and faucet aerators. It may be necessary to upgrade to higher flow rate shower heads if allowable by local code.
6. In areas where the water has a high mineral content, periodic descaling may necessary. See chapter 7.3, page 57 for directions.

### 8.4 Water is not hot enough

1. Selected temperature on the unit is too low. To raise output temperature, see chapter 6.4, page 53.
2. Clean inlet filter screen. See chapter 7.1, page 56 to increase flow through the heater.
3. Inspect the water path for obstructions. Make sure all showerheads, faucet aerators and whole house filters are clear of debris.
4. Confirm the heater's gas type coincides with the type of gas being supplied. See fig. 2, page 11 for location of rating plate.
5. Check inlet gas particle screen for blockage at gas inlet connection on bottom of unit.

6. Verify gas pressure is in accordance with specifications in chapter 4.14, page 49. A gas pressure reading is needed to proceed further. Contact your original installer or a local certified gas technician to obtain this reading.
7. Cold water is mixing into the hot water lines (plumbing crossover). A plumbing crossover can unintentionally mix cold water with the hot water leaving the heater. The end result is a cooler water temperature than desired. To check for a plumbing crossover, shut off the cold water supply to the water heater. Then open all of the hot water taps served by the heater. Wait 10 minutes and check all taps for water flow. There should be no water flowing. Any continuous flow of water, small or large, indicates a crossover and must be corrected. Consult a professional plumber for help in correcting a crossover. Failing single lever faucet mixing valves are common causes of plumbing crossovers.

### 8.5 Low water flow/pressure

1. Too many hot water applications are being used simultaneously or too much flow is demanded. The water heater will effectively support two 2.0-2.5 GPM shower heads simultaneously or multiple sink applications. Greater draws will result in a water pressure drop and reduced flow at taps.
2. Ensure that gas pressure is in accordance with specifications in chapter 4.14, page 49. A gas pressure reading is needed to proceed further. Contact your original installer or a local certified gas technician to obtain this reading. If gas pressure is inadequate, the water heater will close its motorized water valve, reducing the hot water flow rate in an attempt to reach the selected output temperature.
3. If selected temperature on the unit is set too high for the demanded flow rate, the water heater will close its motorized water valve, reducing the hot water flow rate in an attempt to reach the selected output temperature. Lowering the selected temperature will allow the motorized water valve to open up for increased water flow rate.
4. Clean inlet filter screen per chapter 7.1, page 56.
5. Inspect the water path for obstructions. Make sure all shower heads, faucet aerators and whole house filters are clear of debris.

### 8.6 Hot water temperature fluctuates at tap

1. Hot water is very hot out of the water heater, requiring mixing in cold water in order to attain a usable hot water temperature. The addition of too much cold will overpower hot water flow from the tankless water heater. If this slows the flow through the tankless water heater

<Review>

below its activation point, it will shut off the burners. The end result is nothing but cold water coming out of the outlet.

Consult [www.boschheatingandcooling.com](http://www.boschheatingandcooling.com) for a detailed service bulletin on overcoming temperature fluctuations.

2. Unbalanced pressure in water lines. Any restriction in the water heater, such as a clogged inlet filter screen, can result in unequal pressures between the cold and hot water lines. In such cases, when mixing in the higher pressure cold water at the tap, the lower pressure hot water can be overpowered. This will shut down the burners because the hot water flow rate fell below the minimum flow rate required for activation. Verify inlet filter screen is clean and clear of debris. See chapter 7.1, page 56 for inlet filter cleaning instructions.
  3. Heater deactivated by temperature balancing valves. If the outlet water temperature is set too high, the heater can produce temperatures that are too hot. A temperature balance shower valve will automatically mix in cold water to reduce the hot water temperature. In the event of any temperature instability at a fixture using a temperature balancing valve, refer to the valve manufacturer for instructions on internal adjustment setting. An adjustment should be made to minimize the amount of cold water the valve is adding. Additionally, the temperature setting on the heater can be lowered to prevent the temperature balance valve from mixing in too much cold.
  4. Inlet water pressure is erratic due to fluctuating supply water pressure. For installation on a private well system with the use of a pressure tank, the lowest pressure range setting recommended is 40 - 60 psi (2.75 - 4.15 bar). Consult your installer or local plumber for effective ways to maintain constant water pressure to the appliance when on a well system.
4. Cross contamination. Ensure that intake and exhaust terminations maintain required clearances as stated in chapter 4.3, page 15. Cross contamination between intake and exhaust may cause unstable burner flames and noise.
  5. Lack of gas pressure. Inadequate gas pressure will cause the fuel-to-air mixture (CO<sub>2</sub>) to be out of adjustment. This will result in unstable burner flames and noise. Ensure gas pressure is in accordance with specifications in chapter 4.14, page 49 Measuring Gas Pressure. A gas pressure reading is needed to proceed further. Contact your original installer or a local certified gas technician to obtain this reading.
  6. Verify proper CO<sub>2</sub> readings per chapter 7.5, page 59. CO<sub>2</sub> adjustments must be done by a certified gas technician with a calibrated combustion gas analyzer.

## 8.7 Noisy burner/heater during operation

1. Sealed combustion leak. Make sure combustion cover is securely fastened. Ensure the exhaust vent adaptor is properly sealed with supplied gasket. Leaky seals create improper combustion resulting in noise.
2. Improper venting. Venting that is unsealed, the wrong material, too big in diameter or too long in run will result in unstable burner flames and noise. Ensure venting is in accordance with specifications in chapter 4.3, page 15.
3. Lack of adequate combustion air. Drawing combustion air from a room area of inadequate size will result in unstable burner flames and noise. Improper piping of combustion air to the outside or insufficient space will result in unstable burner flames and noise. Ensure adequate combustion air is provided from the unit in accordance with specifications in chapter 4.4, page 38 Combustion Air Requirements.

## 9 Problem solving

### 9.1 Error code diagnostics



To remove error code from the display, press the reset button.

Display	Cause	Solution
<b>A2</b>	Fault in the flue gas limiter. Temperature above 230°F (110 °C) inside the cabinet.	<ol style="list-style-type: none"> <li>1. Check continuity of the flue gas limiter (see fig. 80, page 74). Go to steps two and three to determine flue gas limiter fault and repair it.</li> <li>2. Check for flue gas leakage around the top and bottom seals of heat exchanger, use mirror to check around the rear as well as the viewing window.</li> <li>3. Check that flue gas limiter connector and spade connections are secure.</li> <li>4. Unplug heater and check the wiring harness connections on the control board.</li> </ol>
<b>A3</b>	Wire harness defect.	<ol style="list-style-type: none"> <li>1. Check wire harness. See fig. 87, #7, page 84.</li> <li>2. Measure resistance on wire harness nearby the rubber grommet, must be 115-120 ohm.</li> <li>3. Check diagnostic menu &gt; 1P, "nC" must be showed on the display.</li> </ol>
<b>A4</b>	Backflow temperature sensor defect - happens if sensor is disconnected or short circuit.	<ol style="list-style-type: none"> <li>1. Check backflow temperature sensor connection. See fig. 80, #1, page 74.</li> <li>2. Replace exhaust temperature sensor.</li> <li>3. Check sensor (ref. page 71, chapter 11).</li> </ol>
<b>A7</b>	Outlet temperature sensor fault (Temperature below 36°F or above 210°F).	<ol style="list-style-type: none"> <li>1. Check wire connection at hot water temperature sensor. See fig. 86, page 82.</li> <li>2. Sensor may trip if water temperature drops below 36°F to protect heater from freezing conditions. Any damage due to freezing conditions is not covered under warranty.</li> <li>3. In areas where water has a high mineral content, periodic descaling may necessary.</li> <li>4. Check sensor (ref. page 71, chapter 11).</li> </ol>
<b>A8</b>	Heat exchanger (temperature sensor defect).	<ol style="list-style-type: none"> <li>1. Check wire connection at hot water temperature sensor. See fig. 82, page 76.</li> <li>2. In areas where water has a high mineral content, periodic descaling may necessary.</li> <li>3. Check sensor.</li> </ol>
(Flashing) <b>A9</b>	Outlet temperature sensor not sensing expected output temperature. (Status message, not an error).	<ol style="list-style-type: none"> <li>1. Check wire connection at hot water temperature sensor, see fig. 86, page 82.</li> <li>2. Check gas pressure. Low gas pressure may prevent the heater from reaching desired output temperature.</li> <li>3. Check supply voltage. It must be 120VAC and properly grounded.</li> <li>4. Possible defective control unit call Bosch Water Heating for further instructions.</li> </ol>
<b>C5</b>	Bypass valve solenoid damaged or disconnected.	<ol style="list-style-type: none"> <li>1. Check wire connection at the bypass valve, fig. 86, page 82.</li> </ol>

**<Review>**

Display	Cause	Solution
<b>C6</b>	Primary fan rotation too low in operation.	<ol style="list-style-type: none"> <li>1. Disconnect power supply cord and check wire connection on back side of fan and the connectors on the control board, see fig. 87, page 84.</li> <li>2. Check supply voltage. It must be 120VAC and properly grounded.</li> <li>3. Check venting specifications are met. Long vent lengths, venting with more than three elbows, blocked vent or combination venting may cause this failure.</li> <li>4. Ensure intake and exhaust terminations maintain the required clearances stated in the manual. Cross contamination between intake and exhaust may cause the fan to alter its rotational speed.</li> <li>5. Check gas pressure. Low gas pressure may cause the fan to change its speed to meet desired temperature.</li> <li>6. Possible defective control unit call Bosch Water Heating for further instructions.</li> </ol>
<b>C7</b>	No rotational speed sensor signal from primary fan.	<ol style="list-style-type: none"> <li>1. Disconnect power supply cord and check wire connections on back side of fan and the two connectors on the control board, see fig. 87, page 84.</li> <li>2. Check supply voltage. It must be 120VAC and properly grounded.</li> <li>3. Possible defective component in fan or defective control unit call Bosch Water Heating for further instructions.</li> </ol>
(Flashing) <b>CA</b>	Water flow signal over specified maximum value. Water flow > 10 gallon/min. (Status message).	<ol style="list-style-type: none"> <li>1. Disconnect power supply cord and check wire connections on water valve and the two connectors on the control board, see fig. 87, page 84.</li> <li>2. Excessive water pressure and flow. Ensure water pressure is less than 150psi and flow rate is below 10 gallons per minute.</li> </ol>
<b>E1</b>	Over-temperature detected by outlet temperature sensor. Temperature > 185°F	<ol style="list-style-type: none"> <li>1. Check wire connection at hot water temperature sensor, see fig. 86, page 82.</li> <li>2. In areas where water has a high mineral content, periodic descaling may be necessary. See chapter 7.3, page 57 for directions.</li> <li>3. Check sensor (ref. page 70, chapter 10).</li> </ol>
<b>E2</b>	Cold water temperature sensor fault.	<ol style="list-style-type: none"> <li>1. Check connector on wires coming from top of water valve for a secure connection. See fig. 80, page 74.</li> <li>2. Sensor may trip if water temperature drops below 36°F (2°C). Protect heater from freezing conditions as any damage due to freezing conditions is not covered under warranty.</li> <li>3. Check sensor (ref. page 71, chapter 11).</li> </ol>
<b>E3</b>	Exhaust temperature sensor - the appliance will close the burner and lock if it gets over 194°F; (only applied for condensing unit).	<ol style="list-style-type: none"> <li>1. Clean and check heat exchanger.</li> <li>2. Clean and check condensing heat exchanger.</li> <li>3. Reduce maximum power (chapter 4.14, page 49).</li> <li>4. Reduce water temperature.</li> </ol>
<b>E4</b>	Backflow temperature sensor over 309°F. The appliance will close the burner and lock (non-volatile).	<ol style="list-style-type: none"> <li>1. Check inlet/outlet vent pipes.</li> <li>2. Check if secondary fan connections are disconnected.</li> <li>3. Check if venting specifications are met. Long vent lengths, venting with more than three elbows, blocked vent or combination venting may cause this failure. See chapter 4.3, page 15.</li> <li>4. Call Bosch Water Heating for further instructions.</li> </ol>

Display	Cause	Solution
<b>E9</b>	Overheat sensor (ECO) open circuit (resets when cooler temperatures are detected 220°F/104 °C).	<ol style="list-style-type: none"> <li>1. Disconnect power supply cord and check wire connections on the overheat sensor (fig. 80, page 74) and the two connectors on the control board.</li> <li>2. Check white wire connections at the overheat sensor. Clean terminals with an eraser. If badly corroded, replace sensor and wire harness.</li> <li>3. Check that venting specifications are met. Long vent lengths, venting with more than three elbows, blocked vent or combination venting may cause this failure.</li> <li>4. In areas where water has a high mineral content, periodic descaling may be necessary, see chapter 7.3, page 57.</li> <li>5. Unplug power supply cord to the water heater. Open a hot water tap for several minutes to allow cold water to pass through heat exchanger. Close hot water tap and disconnect lead wires to overheat sensor. Using a multimeter, check continuity through overheat sensor contacts. Replace sensor if open.</li> </ol>
<b>EA</b>	No flame ionization detected with water flow.	<ol style="list-style-type: none"> <li>1. Verify that all manual gas shut off valves are open.</li> <li>2. Check gas type. See fig. 2, page 11.</li> <li>3. Reset error code and open a water tap to cycle the heater in an effort to purge air. Cycling hot water tap on and off multiple times may be necessary. If heater still faults with EA error code, have a licensed gas technician properly purge air out of the gas line leading to the water heater.</li> <li>4. Check three wire connections on the lower front of the heat exchanger are secure.</li> <li>5. Check gas pressure. See chapter 4.14, page 49.</li> <li>6. Check venting specifications are met. Improper venting may cause premature failure of the flame sensor rod. See chapter 4.3, page 15.</li> <li>7. Check that the minimum power fan speed has been adjusted to the proper value. See page 32.</li> <li>8. Observe inside the viewing window of the heat exchanger when a hot water tap is opened. Sparking should be followed by a steady blue flame. If flame is unstable/yellow with proper gas pressure, confirm CO<sub>2</sub> readings per chapter 7.5, page 59.</li> </ol>
<b>EC</b>	Ionization failure during operation.	<ol style="list-style-type: none"> <li>1. Check gas type, fig. 2, page 11.</li> <li>2. Check three wire connections to ignition group on the lower front of the heat exchanger are secure.</li> <li>3. Verify that venting specifications are met. Improper venting may cause premature failure of the flame sensor rod. See chapter 4.3, page 15.</li> <li>4. Check gas pressure. See chapter 4.14, page 49.</li> <li>5. Check and adjust CO<sub>2</sub> readings. See chapter 7.5, page 59.</li> <li>6. Check that the minimum power fan speed has been adjusted to the proper value. See page 32.</li> </ol>

**<Review>**

Display	Cause	Solution
<b>F1</b>	Parameter in memory not found	1. Replace ECU (Electronic Control Unit) if there are repeated errors.
<b>F2</b>	Internal Operations error	
<b>F3</b>	Internal memory parameter error	
<b>F4</b>	Internal memory error	
<b>F5</b>	Analog test fail	
<b>F6</b>	Gas type parameter error	
<b>E7</b>	Appliance parameter not defined	
<b>F0</b>	Burner Control routine state error	
<b>E5</b>	Burner Control error	
<b>E6</b>	Burner Control routine check sum error	
<b>F8</b>	Fan stopping error	1. Check primary fan cable harness 2. Check fan rotation in standby 3. Check proper function of primary fan 4. Replace ECU (Electronic Control Unit)
<b>F9</b>	Gas Control error	1. Check Gas Valve cable harness (connection to gas valve and to ECU) 2. Check Gas Valve (Replace if necessary) 3. Replace ECU (Electronic Control Unit)
<b>F7</b>	Ionization error at standby.	1. Loose connection to the flame ionization rod. Verify that the thinner wire leading from the control unit is securely connected to the set of electrodes located on the lower front of the heat exchanger. 2. Flame ionization rod or control unit may be damaged. Contact Bosch Water Heating for further instruction.
<b>FA</b>	Gas leakage error, gas valve circuit not closing properly.	1. Disconnect power supply cord and check wire connections on gas valve and the two connectors on the control board. 2. Flow water out of a hot water tap above the minimum activation point of 0.5 GPM. Measure voltage at the gas valve wire plug connection. The voltage should measure 24VDC between the left pair of wires and 24VDC between the right pair of wires when the unit is operating. If voltage is not proper, contact Bosch Water Heating for further instruction. 3. Gas valve may be defective, contact Bosch Water Heating for further instruction.

Table 54 \*By installer or service technician only.

&lt;Review&gt;

## 10 Electrical diagram

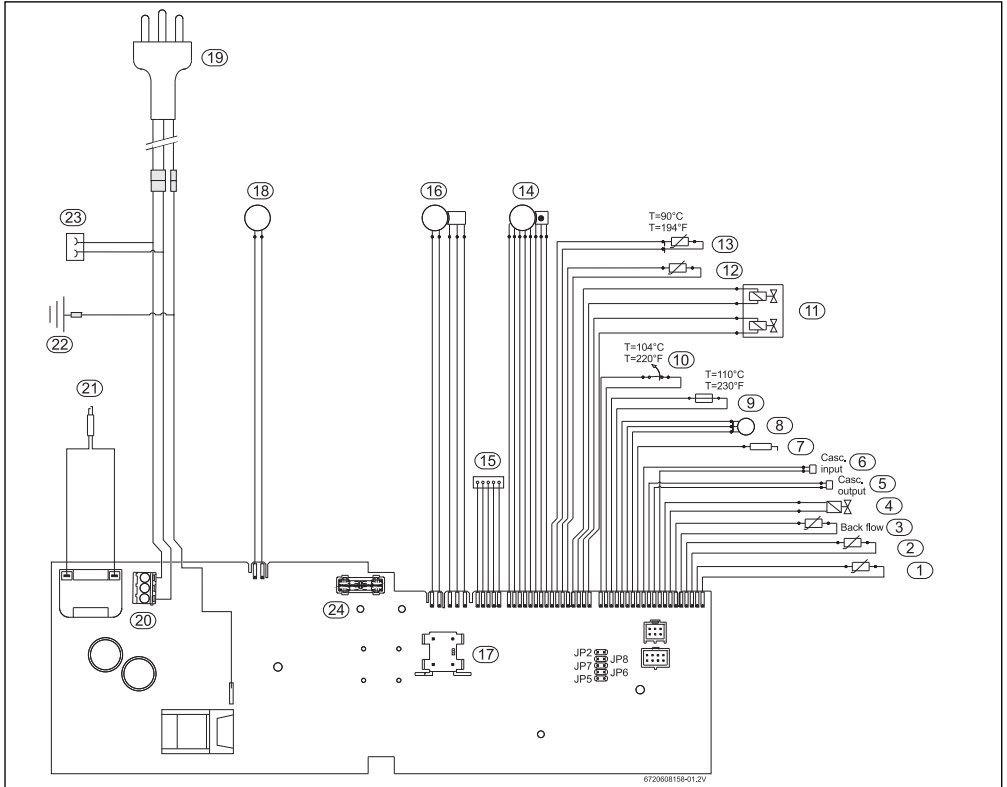

Fig. 76 Electrical scheme

- |                                           |                                |
|-------------------------------------------|--------------------------------|
| [1] Inlet water temperature sensor        | [19] AC plug                   |
| [2] Outlet water temperature sensor       | [20] Main connection           |
| [3] Backflow temperature sensor           | [21] Ignition electrodes       |
| [4] By-pass water valve                   | [22] Ground post               |
| [5] Cascading output connection           | [23] Antifreeze kit connection |
| [6] Cascading input connection            | [24] Fuse                      |
| [7] Ionization sensor                     |                                |
| [8] Water flow sensor                     |                                |
| [9] Flue gas limiter                      |                                |
| [10] Heat exchanger overheat sensor (ECO) |                                |
| [11] Gas valve                            |                                |
| [12] Temperature Heat Exchanger           |                                |
| [13] Exhaust temperature sensor           |                                |
| [14] Water valve                          |                                |
| [15] Communication port                   |                                |
| [16] Primary fan                          |                                |
| [17] ON/OFF switch                        |                                |
| [18] Secondary fan                        |                                |

<Review>

## 11 Sensor resistance charts

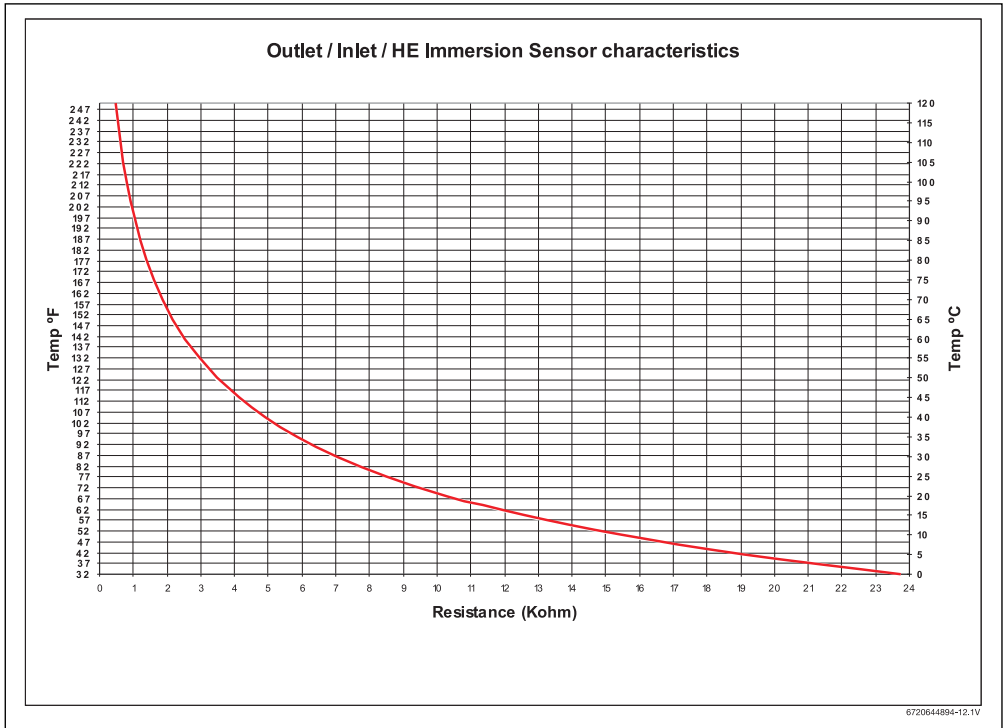
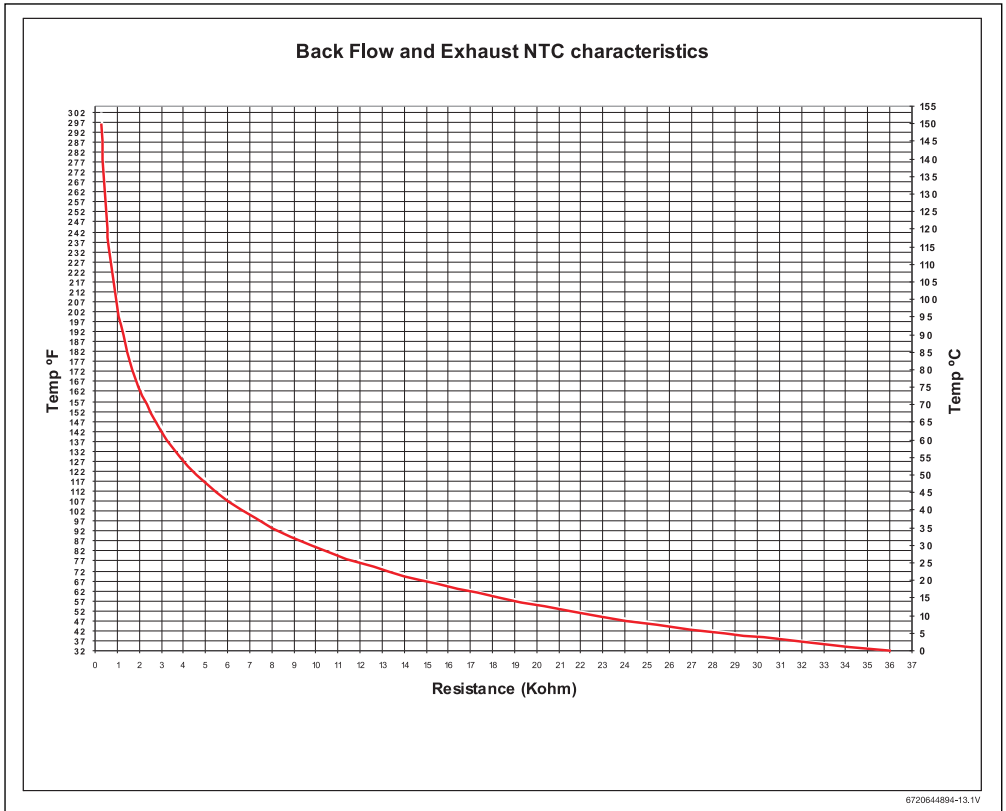

Fig. 77 Outlet / Inlet and HE immersion sensor characteristics

<Review >



<Review>

Fig. 78

**12 Functional scheme**

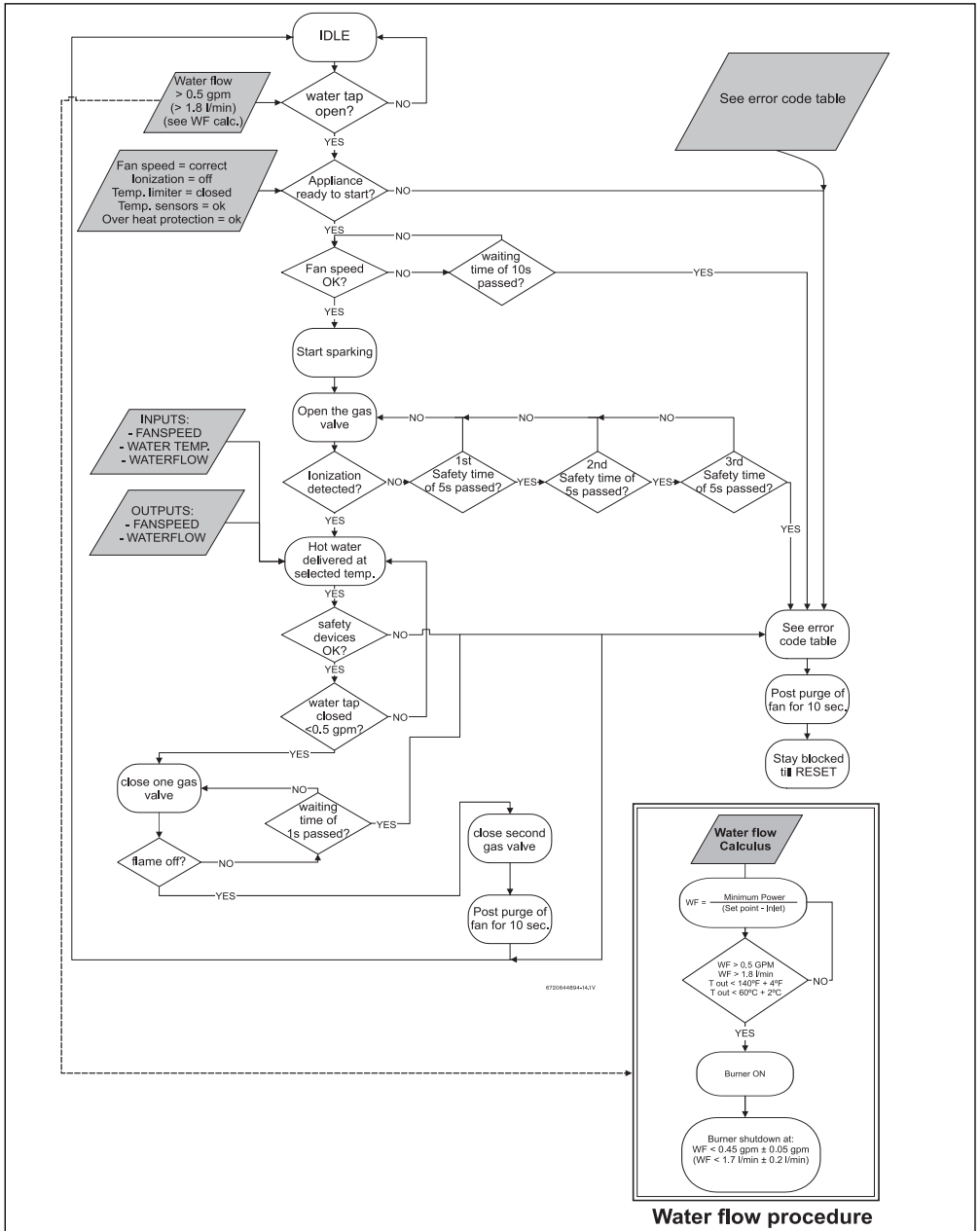

**<Review >**

Fig. 79 Functional scheme

## 13 Interior components diagram and parts list

### 13.1 Interior components

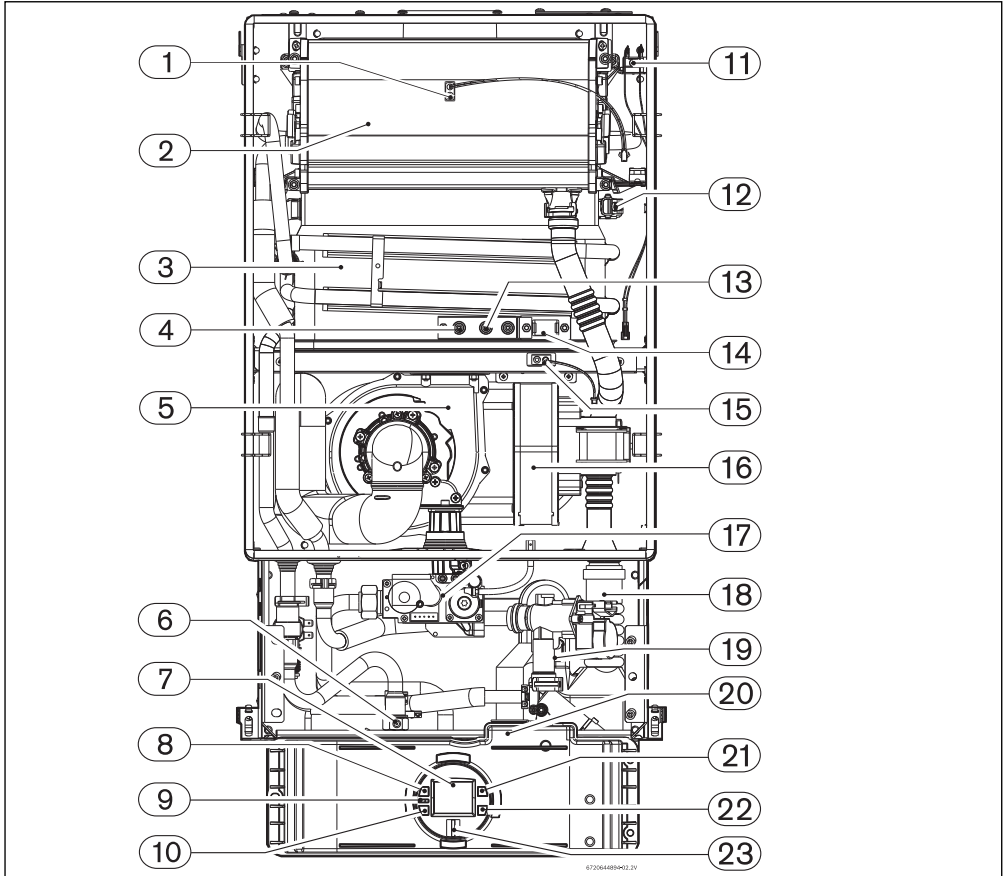
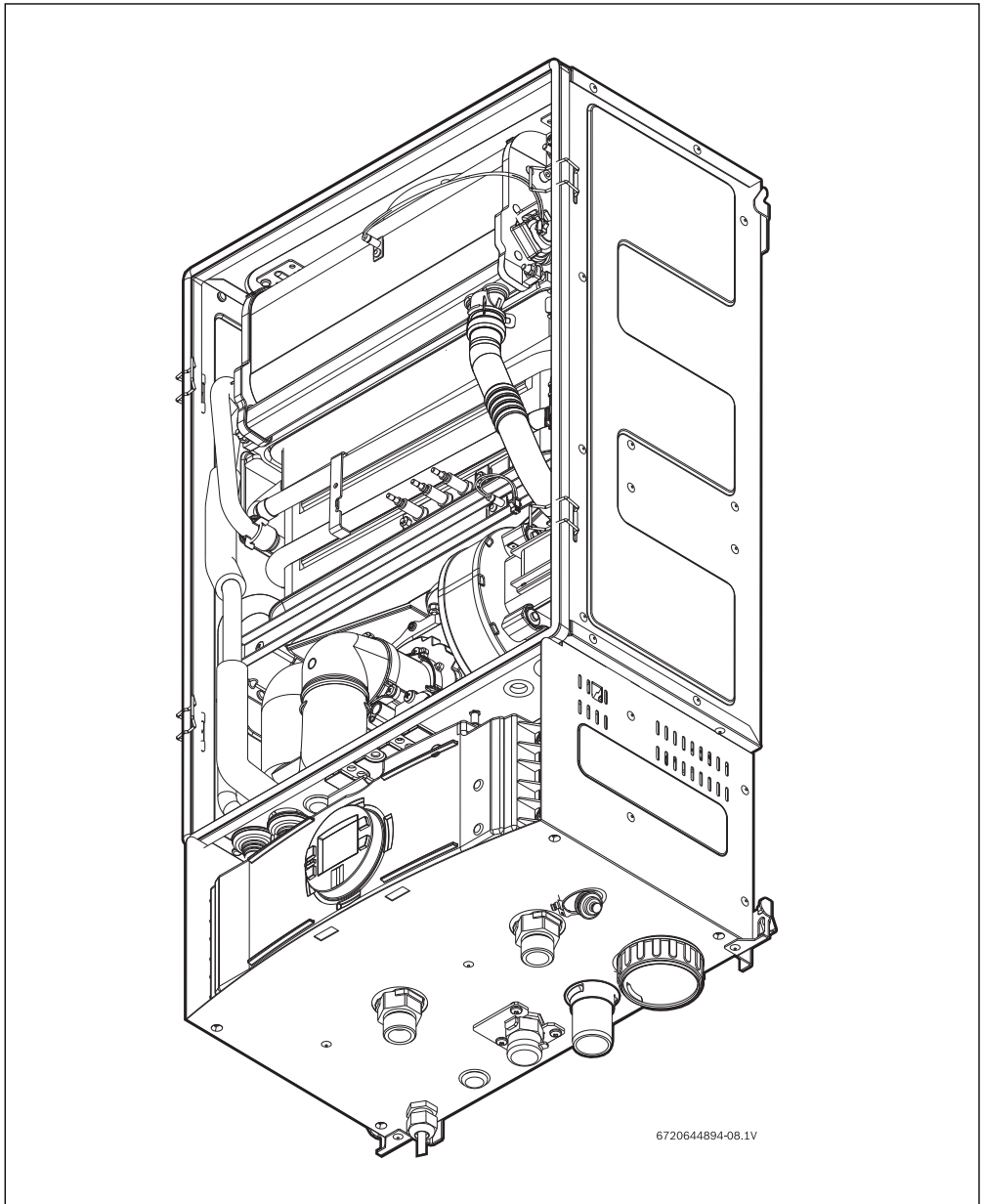

Fig. 80 Components

- |                                           |                                                                     |
|-------------------------------------------|---------------------------------------------------------------------|
| [1] Exhaust temperature sensor            | [13] Ignition electrodes                                            |
| [2] Flue gas collector                    | [14] Observation window                                             |
| [3] Heat exchanger                        | [15] Backflow temperature sensor                                    |
| [4] Ionization sensor                     | [16] Secondary air fan                                              |
| [5] Primary fan (Mixer)                   | [17] Gas valve                                                      |
| [6] Hot water temperature sensor          | [18] Condensate trap                                                |
| [7] LCD display                           | [19] Water valve with flow sensor and cold water temperature sensor |
| [8] On/Off button                         | [20] Control unit                                                   |
| [9] Reset button                          | [21] Up button                                                      |
| [10] Program key                          | [22] Down button                                                    |
| [11] Flue gas limiter                     | [23] LED                                                            |
| [12] Heat exchanger overheat sensor (ECO) |                                                                     |

**<Review>**

<Review >



6720644894-08.1V

Fig. 81 Appliance overview

### 13.2 Components diagram

#### 13.2.1 Group 1

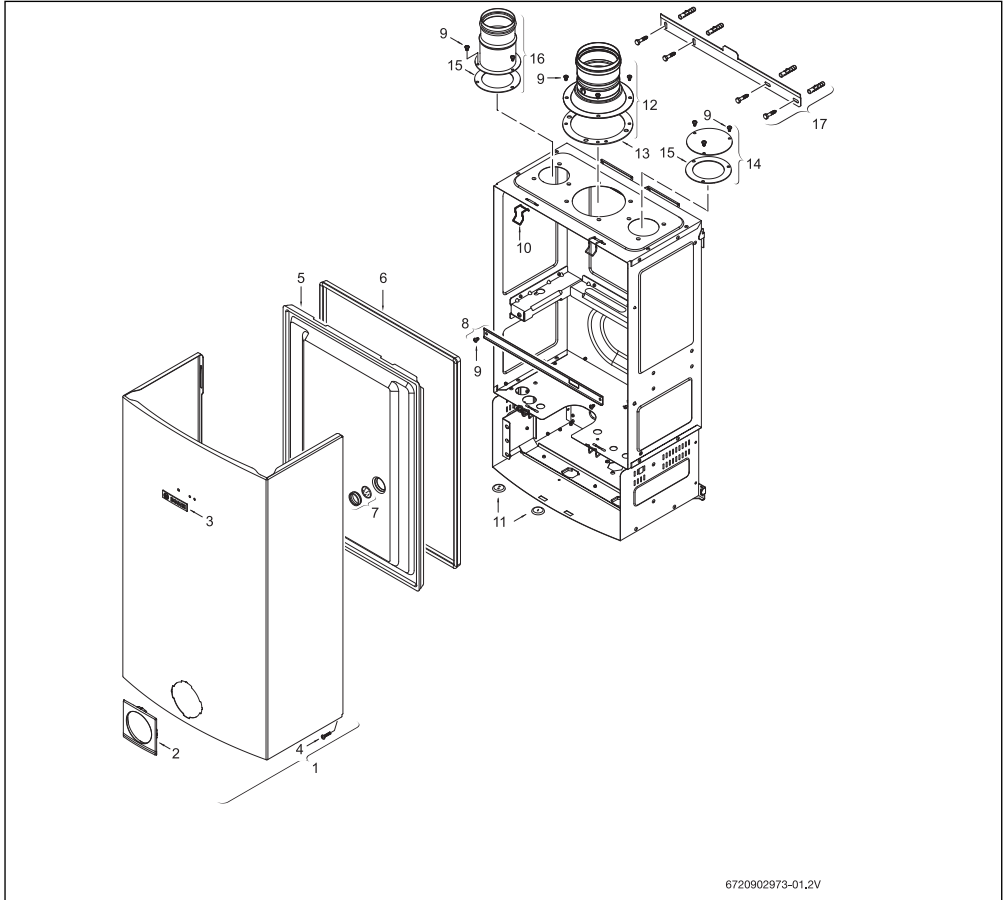

6720902973-01,2V

Fig. 82 Components Diagram

**<Review>**

Item	Description	Reference
1	Front cover	8 738 708 387
2	Cover shield	8 738 708 388
3	Trade mark badge	8 701 103 140 0
4	Cover screw	8 703 401 170 0
5	Combustion cover	8 700 506 300 0
6	Combustion cover gasket	8 704 701 084 0
7	Observation window	8 705 600 003 0
8	Holding bracket	8 708 104 103 0
9	Screw	8 703 403 012 0

Item	Description	Reference
10	Combustion cover clip	8 701 201 032 0
11	Grommet set	8 710 203 039 0
12	Exhaust accessory	8 705 504 166
13	Gasket exhaust	8 700 103 710 0
14	Inlet air cover	8 708 006 022 0
15	Inlet air gasket	8 700 103 166 0
16	Inlet air accessory	8 705 504 116
17	Mounting bracket	8 701 309 164 0

Table 55

13.2.2 Group 2

<Review>

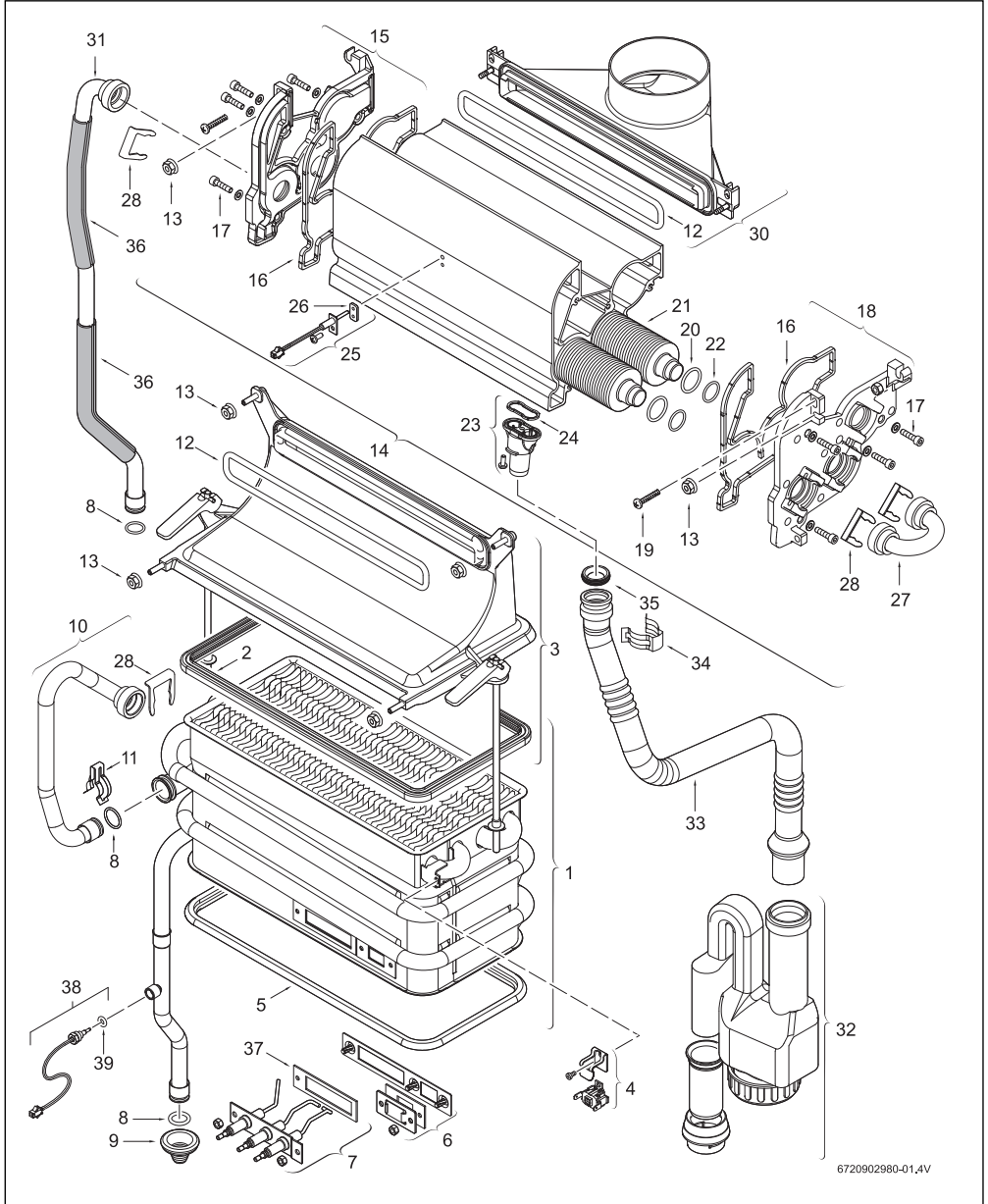

6720902980-0,1,4V

Fig. 83 Components Diagram

Item	Description	Reference
1	Heat exchanger (LP Gas)	8 738 704 026 0
1	Heat exchanger (Natural Gas)	8 738 704 117 0
2	Heat exchanger top gasket	8 704 701 052 0
3	Condensing exchanger inlet	8 705 700 159 0
4	Overheat sensor (ECO)	8 707 206 204 0
5	Heat exchanger bottom gasket	8 704 701 054 0
6	Sight window	8 701 000 401 0
7	Ignition group	8 701 302 249 0
8	Heat exchanger O-ring	8 700 205 147 0
9	Rubber grommet	8 710 303 027 0
10	Connecting pipe	8 700 715 493 0
11	Pipe connection clip	8 701 201 028 0
12	Condensing exchanger gasket	8 704 701 090 0
13	Condensing exchanger nut	8 703 301 157 0
14	Condensing heat exchanger	8 705 700 161 0
15	Condensing exchanger left side	8 705 700 162 0
16	Condensing exchanger side	8 704 701 091 0
17	Allen screw	2 918 060 162 0
18	Condensing exchanger right	8 705 700 163 0
19	Screw	2 910 611 496 0
20	Fincoil O-ring	8 700 205 226 0
21	Condensing fincoil	8 700 715 402 0
22	O-ring	8 700 205 228 0
23	Condensate drain connector	8 705 506 838 0
24	Condensate drain connector	8 704 701 092 0
25	Exhaust temperature sensor	8 707 206 459 0
26	Washer	8 704 701 097 0
27	U-bend pipe	8 703 305 352 0
28	Condensing exchanger clip	8 701 300 023 0
30	Flue gas collector	8 705 506 841 0
31	Cold water pipe upper	8 700 715 398 0
32	Siphon	8 705 202 141 0
33	Condensate drain pipe	8 700 703 177 0
34	Condensate drain pipe clip	8 716 102 607 0
35	Condensate drain pipe O-ring	8 704 701 094 0
36	Insulation (145x60)	8 702 303 027 0
37	Washer	8 704 701 088 0

Item	Description	Reference
38	Temperature Sensor	8 700 400 040 0
39	O-ring	8 700 205 310 0

Table 56

**<Review>**

13.2.3 Group 3

<Review>

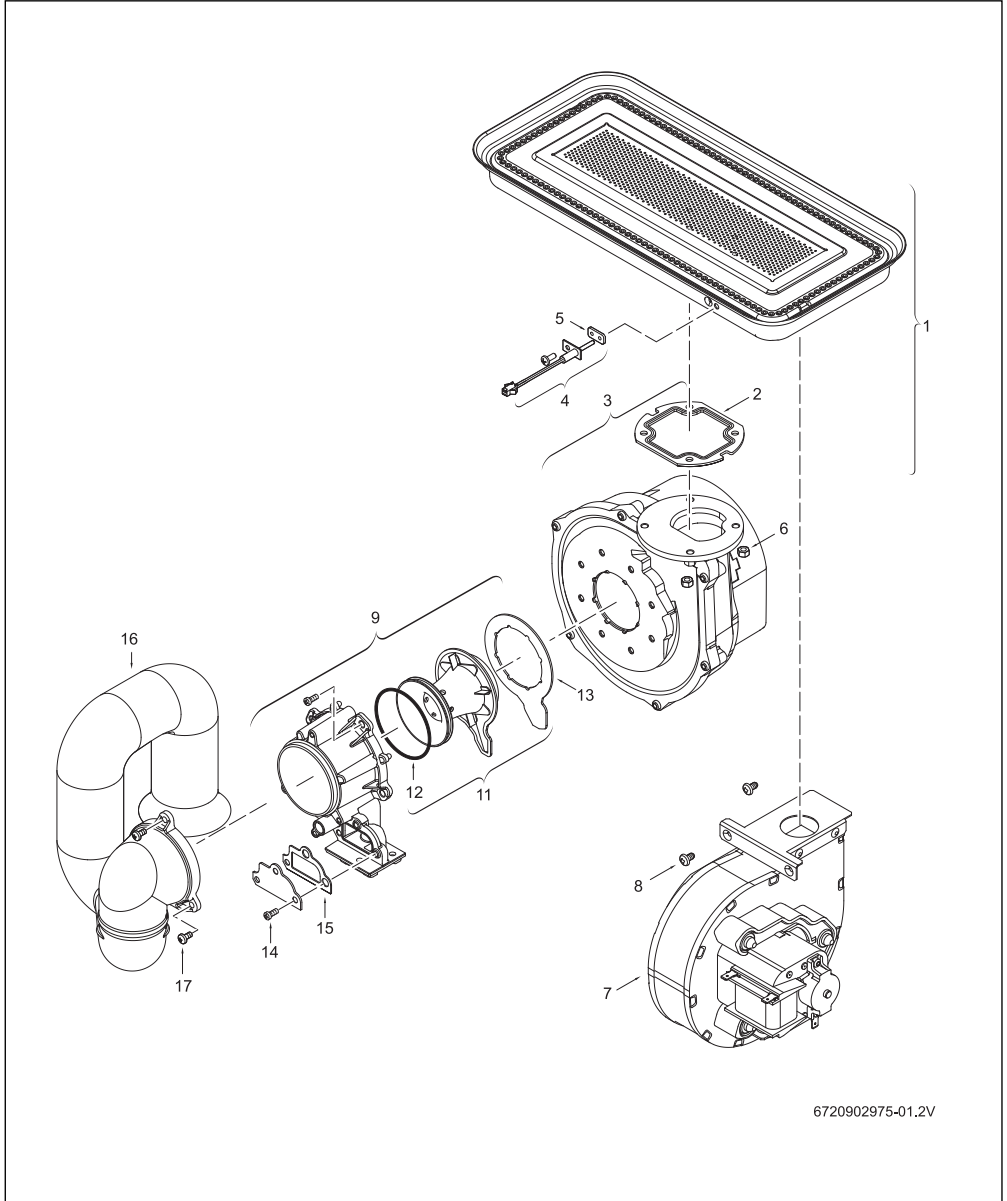

6720902975-01.2V

Fig. 84 Components Diagram

Item	Description	Reference
1	Main burner (Natural Gas)	8 708 120 642 0
1	Main burner (LP Gas)	8 708 120 699 0
2	Burner gasket	8 704 701 087 0
3	Primary fan	8 707 204 071 0
4	Backflow temperature sensor	8 707 206 459 0
5	Washer	8 704 701 097 0
6	Fan mount nut	2 915 011 006 0
7	Secondary fan (LP Gas)	8 707 204 074 0
7	Secondary fan (Natural Gas)	8 707 204 072 0
8	Screw	8 703 403 012 0
9	Gas / Air Mixer	8 705 700 170 0
11	Venturi	8 700 306 226 0
12	O-ring	8 700 205 224 0
13	Mixer / Fan gasket	8 704 701 059 0
14	Screw	2 910 642 150 0
15	Plate gasket	8 701 004 049 0
16	Air supply duct	8 705 700 155 0
17	Screw	2 910 952 122 0

Table 57

<Review>

**13.2.4 Group 4**

**<Review>**

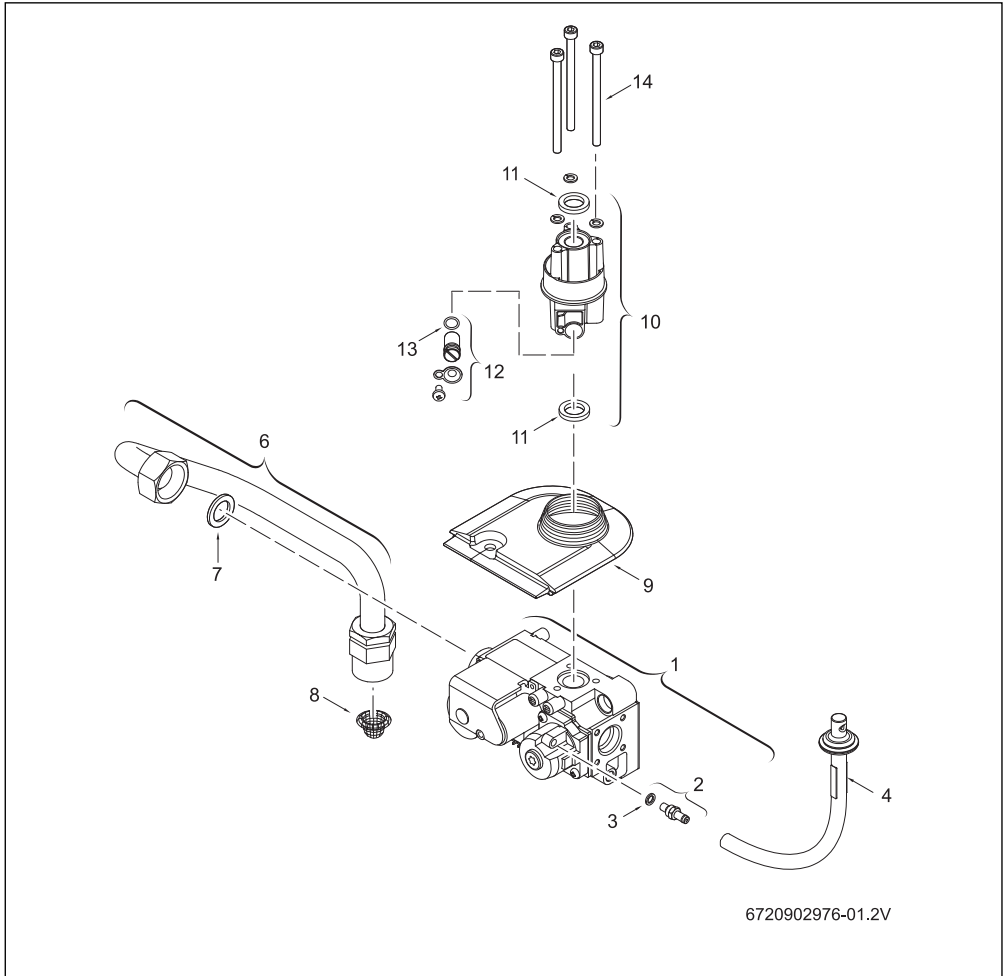

6720902976-01.2V

Fig. 85 Components Diagram

Item	Description	Reference
1	Gas valve	8 707 021 019 0
2	Pressure tapping	8 703 404 219 0
3	Washer	8 700 203 041 0
4	Pipe	8 718 221 063 0
6	Gas supply pipe	8 700 715 389 0
7	Gas valve washer	8 700 103 014 0
8	Gas filter	8 700 507 002 0

Item	Description	Reference
9	Gasket	8 704 701 085 0
10	Gas / Fan connector	8 705 202 140 0
11	Washer	8 704 701 062 0
12	Regulation screw	8 703 404 220 0
13	O-ring	8 700 205 009 0
14	Screw	2 910 149 181 0

Table 58



Item	Description	Reference
1	Water valve with engine and temperature sensor	8 708 505 023 0
2	O-ring	8 700 205 147 0
3	Clip	8 716 102 607 0
4	Cold water pipe	8 738 703 468 0
5	Insulation	8 703 303 027 0
6	Clip	8 701 201 028 0
7	Bypass valve	8 738 702 561 0
8	Washer	8 710 103 043 0
9	O-ring bypass	8 716 103 067 0
10	Clip bypass	8 701 201 020 0
11	Bypass water pipe	8 738 703 467 0
12	O-ring bypass	8 700 205 129 0
13	Hydraulic block	8 738 704 163 0
14	Filter	8 700 507 059 0
15	Filter cover	8 738 702 550 0
16	Wireform spring	8 704 705 029 0
17	O-ring filter cover	8 700 205 312 0
18	Wireform spring	8 704 705 055 0
19	O-ring	8 700 205 157 0
20	Temperature sensor	8 700 400 033 0
21	O-ring	8 700 205 310 0
22	Connection bush	8 738 702 558 0
23	Clip	8 701 300 025 0
24	Connection bush	8 738 702 548 0
25	Hot water pipe	8 738 702 559 0
26	Connector T	8 738 702 577 0
27	Clip	8 738 704 185 0

Table 59

&lt; Review &gt;

13.2.6 Group 6

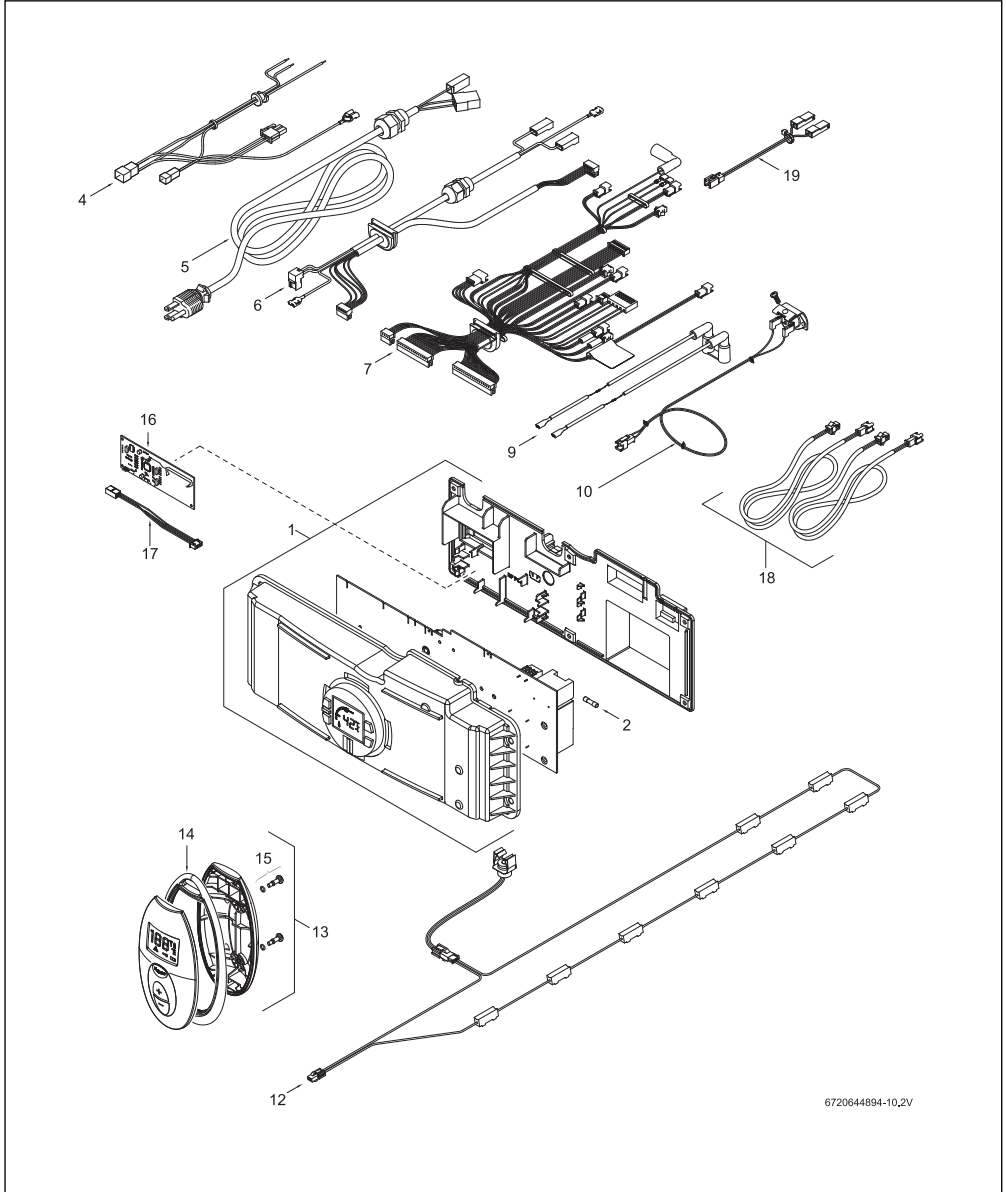

<Review>

Fig. 87 Components Diagram

Item	Description	Reference
1	Control unit	8 738 708 389
2	Fuse T2.5A	1 904 521 342 0
4	Power supply cables	8 704 401 371 0
5	Power supply cord	8 704 401 378 0
6	Fan cables	8 704 401 347 0
7	Wire harness	8 738 702 804 0
9	Electrode cables	8 704 401 346 0
10	Flue gas limiter	8 700 400 032 0
12	Anti freeze kit	7 709 003 665
13	Remote control (optional)	7 709 003 213
14	Shaped seal (optional)	8 700 201 012 0
15	Screw (optional)	8 703 401 109 0
16	Printed circuit transceiver	8 708 300 123 0
17	Transceiver cable	8 704 401 244 0
18	Kit Intelligent Cascading	7 709 003 962
19	Bypass wire	8 738 702 551 0

Table 60

&lt;Review&gt;

## 14 Protecting the environment

### Packing

The packing box may be fully recycled as confirmed by the recycling symbol .

### Components

Many parts in the heater can be fully recycled in the end of the product life. Contact your city authorities for information about the disposal of recyclable products.

### Saving water resources:

- ▶ Make sure you close all the taps after any use. Avoid leaving the taps dripping. Repair any leaking tap.
- ▶ Define the temperature you want, in the appliance or with the remote control. This way you have the precise water flow needed (mixing cold water to regulate temperature will increase the water flow with consequent waste of water).

## 15 Installer Checklist to be completed by installer upon installation

Serial Number (8 digit serial number is located on rating plate on right side panel)	_____
Gas Pressure Reading <sup>1)</sup>	
Static	
Operating	
Water Pressure	
Building Water Pressure	
Range if on Well system	
Installing Company	
Installer name	
Address	
Phone	

**<Review>**

1) See chapter 4.14, page 49 and gas pressure table (to be filled out by installer)

Table 61



Installation manual should be left with the owner after the installation is tested and completed.

<Review>



6720805440

<Review>

Bosch Thermotechnology Corp.  
50 Wentworth Avenue  
Londonderry, NH 03053  
Tel. 603-552-1100  
Fax 603-965-7581  
[www.boschheatingandcooling.com](http://www.boschheatingandcooling.com)  
U.S.A.

Products manufactured by  
Bosch Termotecnologia SA  
Estrada de Cacia  
3800-533 Cacia  
Portugal

Bosch Thermotechnology Corp. reserves the right  
to make changes without notice due to continuing  
engineering and technological advances.