



Contents

- Panel descriptions** 2
- Top panel 2
- Rear panel (connecting your equipment) 3
 - Installing the batteries 3
- Outputting sound** 4
- Turning the power on/off 4
- Setting the connected device type 4
- Selecting a bass amp type (output select) 4
- Adjusting the volume (output level) 4
- Tuning your bass (tuner) 4
- Effect signal chain 5
- Signal flow 5
- Saving/recalling sounds (memory mode)** 6
- How the memories are structured 6
- Switching between manual/memory mode 6
- Setting what happens when switching from memory mode to manual mode 6
- Selecting a sound (memory) 6
 - Checking the knob positions 6
 - Configuring what happens when switching banks 7
- Saving a sound (memory write) 7
- Changing the settings for sounds (memory edit mode) 7
- Useful functions** 8
- Adding effects that follow your tempo (tap tempo) 8
- Setting the modulation speed or delay time with the pedal 8
- Performing with phrase loops 9
- Configuring the [CTL] (control) pedal functions 10
 - Setting the pedal function 10
 - Configuring the pedal operations 10
- Connecting to and using an external effect unit via the SEND/RETURN jacks 11
- Calibrating the expression pedal 11

- Connecting to your computer via USB** 12
- Installing the USB driver 12
- Transmitting/receiving audio signals between your computer and the ME-90B (USB audio) 12
- Transmitting/receiving MIDI data between a computer and the ME-90B (USB MIDI) 13
- Loading IR data to use this unit as a speaker simulator 13
- Wireless connection with a mobile device** 14
- Attaching the BT-DUAL 14
- Listening to sound via wireless connection with a mobile device 14
 - Registering a mobile device (pairing) 14
 - Connecting an already-paired mobile device 15
- Disabling Bluetooth functionality 15
- Controlling the ME-90B from the dedicated app on your mobile device 15
 - Connecting to the dedicated app 15
 - Operating the ME-90B wirelessly with an EV-1-WL/FS-1-WL 15
- Configuring the device overall (system settings)** 16
- Parameter list 16
- Restoring the factory settings (factory reset)** 17
- Troubleshooting** 18
- Main specifications** 19

Panel descriptions

Top panel

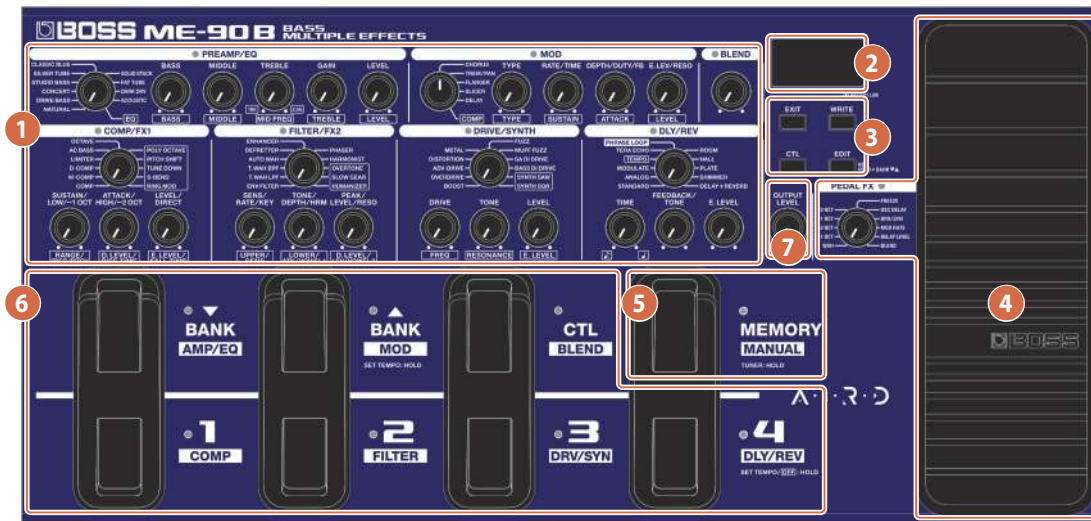

1 Effect configuration knobs

Use these knobs to configure the various effects built into the ME-90B.

- * For details on the effect parameters, refer to the “ME-90B Parameter Guide” (BOSS website).

2 Display

Shows various information for the ME-90B.

MEMO

When the batteries are running low, the BATTERY LOW indicator blinks on the display.



Replace the batteries with new ones.

3 [EXIT], [WRITE], [CTL], [EDIT] buttons

Button	Explanation
[EXIT]	Press to return to the previous screen or to undo an operation.
[WRITE]	Press to save your memory settings or to execute a copy operation (p. 6).
[CTL]	In memory mode, this configures the operation of the [CTL] pedal (p. 6).
[EDIT]	Enters memory edit mode (p. 7).

4 Expression pedal

Press the toe end of the pedal to switch the pedal effect on/off (the PEDAL FX indicator turns on/off).

Pedal effect	Indicator	Pedal operation
Off	Unlit	Volume pedal
On	Lit	Controls the effect (such as wah) that you set using the [PEDAL FX] knob.

- * When you operate the expression pedal, please be careful not to get your fingers pinched between the movable part and the unit. In places where small children are present, make sure that an adult provides supervision and guidance.

5 [MEMORY/MANUAL] pedal

Switches between memory mode and manual mode (p. 6).

Keep this pressed for two seconds or more to turn the tuner on (p. 4).

6 Pedal switch

Switches between banks and memories when the unit is in memory mode. In manual mode, this turns each effect on/off.

When in memory mode

Use the pedal switches to switch between banks and memories.

Switch	Function
[BANK ▼], [BANK ▲]	Switches between banks.
[1]–[4]	Switches between memories.
[CTL]	Performs the operation that’s set in “Configuring the [CTL] (control) pedal functions” (p. 10).

When in manual mode

Use the pedal switches to individually switch each effect (COMP/FX1, FILTER/FX2, DRIVE/SYNTH, AMP/EQ, MOD, DLY/REV, BLEND) on/off.

What is “memory mode”?

The effect combinations and settings (sounds) are recalled as “memories”. There are 72 memories.

Out of the 72 memories, 36 (4 memories × 9 banks) can be saved in the user banks (9 banks of presets and 9 user banks).

You can use the pedal to instantly switch between banks and memories.

What is “manual mode”?

This mode lets you use the pedals to turn each effect on/off.

This lets you use this unit as if you were individually switching the compact effects on an effect unit board on/off.

7 [OUTPUT LEVEL] knob

Adjusts the signal volume from the OUTPUT and PHONES jacks.

- * This does not adjust the volume for the BALANCED OUTPUT connector.

Rear panel (connecting your equipment)



1 BALANCED OUTPUT connector

Connect this to your PA mixer or other audio equipment. The output from this connector is always set to "LINE", regardless of the [AMP/LINE] switch setting.

* Pin assignment of BALANCED OUTPUT connector



2 [GND/LIFT] switch

You can lift pin #1 (GND) of the BALANCED OUTPUT connector from the ground loop of the ME-90B.

Switch this to "LIFT" if you hear humming or noise as a result of ground loop. Normally, this should be set to "GND".

3 INPUT jack

Connect your bass guitar here.

4 OUTPUT jacks

Connect these to your bass guitar amp, mixer or other audio equipment. For a mono connection, use only the L/MONO jack.

5 [AMP/LINE] switch

Set this to "AMP" when connecting this unit to a bass guitar amp. Set this to "LINE" when connecting this unit to a mixer or powered speakers. This ensures the optimum output to match the connected device.

6 PHONES jack

Connect a pair of headphones or a recorder (sold separately) with a stereo mini plug here. Set the [AMP/LINE] switch to "LINE".

7 SEND/RETURN jacks

Connect an external effect unit here.

You can connect an external effect unit between the SEND jack and RETURN jack, and use it as one of the ME-90B's effect units (p. 11).

8 Bluetooth ADAPTOR jack

Connect the **Bluetooth**® Audio MIDI Dual Adaptor (part number BT-DUAL, sold separately) to wirelessly play back music from your mobile device such as a smartphone or tablet (hereafter "mobile device"), or to edit the effects using an app on your mobile device (p. 14).

Use the volume control on your audio player to adjust the volume of signal output received from the OUTPUT jacks and PHONES jack.

9 USB COMPUTER port

Connect this port to your computer via USB cable. This lets you transmit/receive audio signals between the ME-90B and your computer, use the ME-90B dedicated app to edit the sounds and so on (p. 12).

* Do not use a USB cable that is designed only for charging a device. Charge-only cables cannot transmit data.

10 [POWER] switch

This switches the power on and off (p. 4).

11 DC IN jack

Accepts connection of an AC adaptor (BOSS PSA-S series; sold separately).

* Use the cord hook to secure the cord of the AC adaptor as shown in the illustration.



* To prevent malfunction and equipment failure, always turn down the volume, and turn off all the units before making any connections.

12 Ground terminal

Connect this to an external earth or ground if necessary.

Installing the batteries

Install the batteries into the battery case at the bottom of this unit. Make sure that the batteries face the right way.

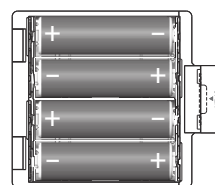

* When turning the unit over, be careful so as to protect the buttons and knobs from damage. Also, handle the unit carefully; do not drop it.

* We recommend that you keep batteries installed in the unit even though you'll be powering it with the AC adaptor. That way, you'll be able to continue a performance even if the cord of the AC adaptor gets accidentally disconnected from the unit.

* If you handle the battery (batteries) improperly, you risk explosion and fluid leakage. Make sure that you carefully observe all of the items related to the battery (batteries) that are listed in "USING THE UNIT SAFELY" and "IMPORTANT NOTES" (leaflet "USING THE UNIT SAFELY").

Outputting sound

Turning the power on/off

* Before turning the unit on/off, always be sure to turn the volume down. Even with the volume turned down, you might hear some sound when switching the unit on/off. However, this is normal and does not indicate a malfunction.

Turning the power on

1. Press the ME-90B's [POWER] switch to turn on the power.
2. Turn on your bass amp that's connected.

Turning the power off

1. Check the following before turning the power off.
 - Is the volume turned down to minimum on all connected devices?
 - Have you saved any memories that you've edited? (p. 7)
2. Turn off your bass amp and other devices connected to this unit.
3. Press the ME-90B's [POWER] switch to turn off the power.

NOTE

When the power is turned off, any settings you were editing will be lost. You must save settings that you want to keep.

Setting the connected device type

Set the [AMP/LINE] switch according to the device you're using.

Setting	Explanation
LINE	When connecting a mixer, powered speakers or headphones
AMP	When connecting a bass amp

Selecting a bass amp type (output select)

1. Press the [MEMORY/MANUAL] pedal to switch to manual mode (p. 6).
2. Press the [EDIT] button.
3. Use the [BANK ▼] [BANK ▲] pedals to select the type of bass amp (1-2).

Display	Explanation
1	Use this setting when connecting to a tweeter-equipped bass amp.
2	Use this setting when connecting to a bass amp that has no tweeter.

4. Press the [WRITE] button.

This saves the settings.

Adjusting the volume (output level)

1. Use the [OUTPUT LEVEL] knob to adjust the overall volume.

Tuning your bass (tuner)

1. Hold down the [MEMORY/MANUAL] pedal for at least two seconds.

This turns the tuner on. The MEMORY/MANUAL indicator lights up yellow.

2. Adjust the reference pitch if necessary.

The reference pitch is shown when you press the [EDIT] button. The pitch increases each time you press the button, from 435 Hz to 445 Hz. If the pitch is already 445 Hz and you press the button, the pitch returns to 435 Hz.

If you don't press the [EDIT] button within two seconds, the unit returns to regular tuner mode.

Display	Pitch
35-45	435-445 (Hz)

MEMO

- The reference pitch is shown for a certain amount of time in the display.
 - The reference pitch is saved, so you don't need to set it each time you tune your bass guitar.
 - This is set to "40" (440 Hz) when using the factory settings.
3. Play a single note on the open string you want to tune.

The name of the pitch that's closest to the string you played is shown in the display.

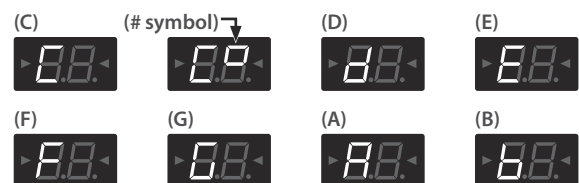

4. Adjust the tuning of each bass guitar string so that both tuning guides are illuminated.



5. To turn the tuner off, press any pedal switch.

Output settings when using the tuner

When the tuner is on, you can set whether to output the audio from the OUTPUT/PHONES/BALANCED OUTPUT jacks and connector or not.

For details, refer to "Configuring the device overall (system settings)" (p. 16).

* If you've switched the audio output on, you can use the expression pedal to adjust the volume.

Effect signal chain

The signal chain (how the effects are generally connected) on the ME-90B is shown below.

EFFECT CHAIN

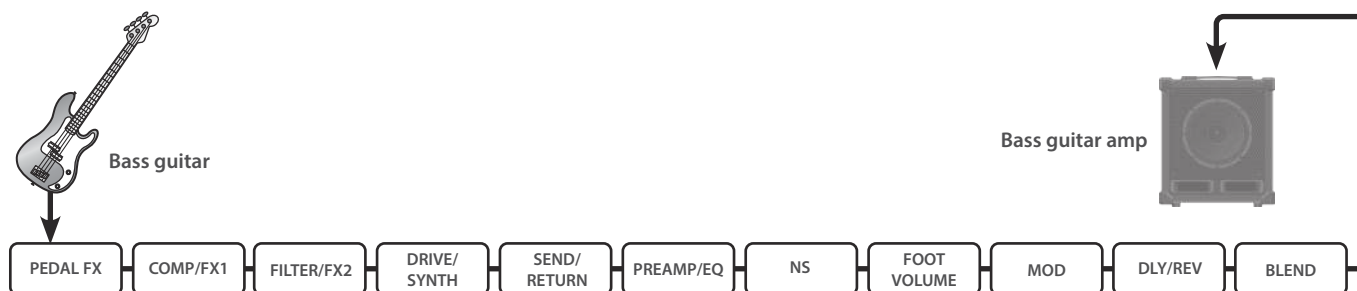

The signal chain is automatically optimized to match the effect type that's selected. You can change the SEND/RETURN to come after the PREAMP/EQ. For details, refer to "Configuring the device overall (system settings)" (p. 16).

* For details on the effect parameters, refer to the "ME-90B Parameter Guide" (BOSS website).

Effect	Explanation
PEDAL FX	Lets you achieve various effects using the expression pedal on this unit. You can turn the pedal effect on/off by pushing the expression pedal up with your weight on your toes. When the pedal effect is off, the expression pedal works as a volume pedal.
COMP/FX1	Averages out the volume, giving a sustained sound without distortion. You can also select from a variety of unique effects.
FILTER/FX2	Produces a wah effect as you open and close the filter.
DRIVE/SYNTH	Distorts or processes the input audio to create a synth-like sound.
SEND/RETURN	You can connect an external effect unit to the SEND and RETURN jacks, and use it as one of the ME-90B's effects.
PREAMP/EQ	Models the characteristics of a preamp. This also adjusts the tonal character of the sound.
NS	Reduces the noise and hum picked up by bass pickups.
FOOT VOLUME	When the pedal effect is off, the expression pedal works as a volume pedal.
MOD	Adds spaciousness or an undulating character to the sound.
DLY/REV	Delays the sound to create an echo-like effect. Use this to add thickness or for tricky-sounding effects. You can also use this to add reverberations to the sound.
BLEND	Adjusts the volume of the direct sound.

Signal flow

The signal flow on the ME-90B is as follows.

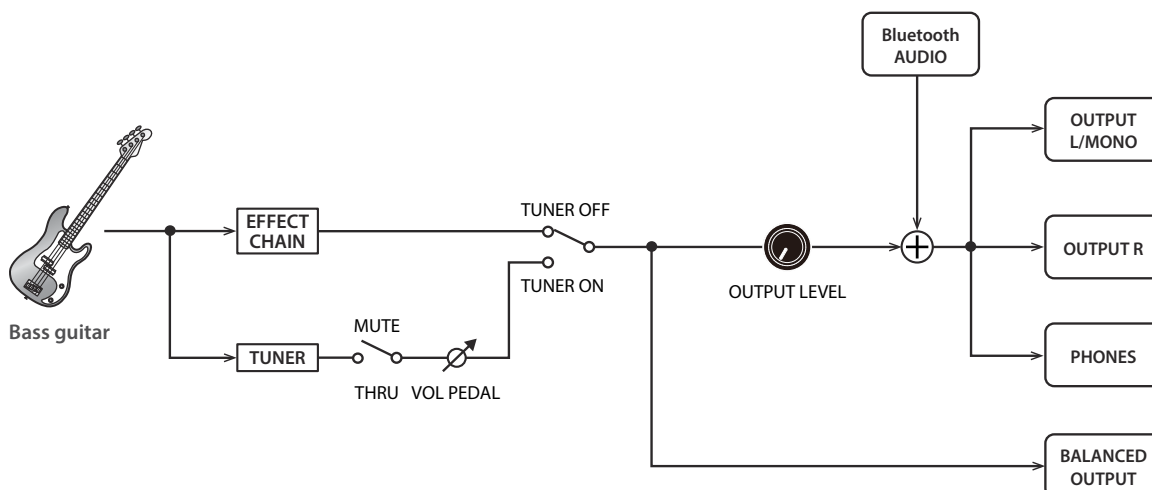

Saving/recalling sounds (memory mode)

With memory mode, you can save the sound settings to this unit, and recall what you saved afterwards. In contrast, “manual mode” lets you switch each effect on/off using the pedals.

How the memories are structured

A combination of effects and the parameter settings is called a “memory”.

The ME-90B can store 72 different memories. These memories are organized by bank and number as shown below.

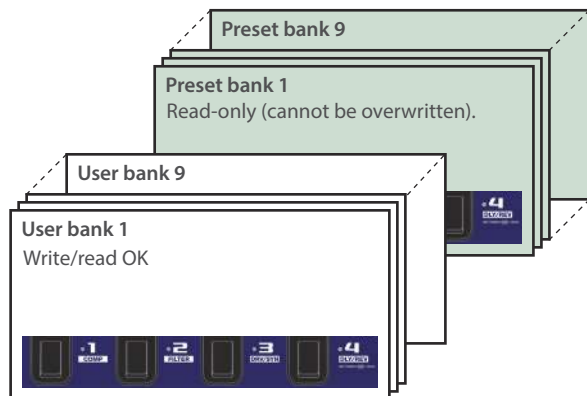

Each memory within a bank corresponds to a numbered pedal.

Switching between manual/memory mode

1. Press the [MEMORY/MANUAL] pedal.

Press this pedal to toggle between manual mode and memory mode.

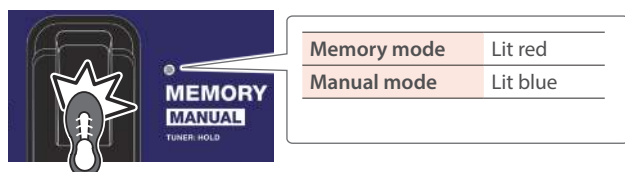

Setting what happens when switching from memory mode to manual mode

When switching from memory to manual mode, you can select whether the sound switches according to the knob settings on the panel, or whether the memory mode sound carries over.

For details on how to configure the settings, refer to “Configuring the device overall (system settings)” (p. 16).

Display	Explanation
nn	When you switch to manual mode, the current knob settings are applied to the sound.
n1	When you switch to manual mode, the memory mode settings are carried over. You can turn the individual effects on/off while using the same memory mode settings (factory settings). The manual mode settings are retained when you switch from manual to memory mode.

Selecting a sound (memory)

Use the [BANK▼] [BANK▲] pedals and the numbered [1]–[4] pedals to recall (switch between) memories.

1. Press the [BANK▼] [BANK▲] pedals to select the bank number.



Display	Bank
U 1–49	User banks
P 1–9	Preset banks

2. Press one of the numbered [1]–[4] pedals.

The patch switches to the memory of the bank number you selected in step 1.



MEMO

When selecting a memory within the same bank, you can skip step 1.

Checking the knob positions

When you recall a sound (memory) in memory mode (p. 6), the value of the parameters you’re setting may differ from the position indicated by the knobs.

You can make the actual parameter value show up in the display, so that you can check it.

1. Hold down the [EDIT] button and turn the knob for the parameter you want to check.

The knob value is shown in the display.

When the knob’s position and value match, the tuning guides on both sides of the display light up.



Configuring what happens when switching banks

For switching banks using the [BANK▼] [BANK▲] pedals, you can select whether to instantly switch to the next memory, or instead to wait before switching to the next memory until you press a numbered pedal.

For details on the settings, refer to “Configuring the device overall (system settings)” (p. 16).

Display	Explanation
h 0	Pressing the bank pedal to switch banks only changes the bank shown in the display, without actually switching to a different memory. Both the bank and number are confirmed right when you press a numbered pedal, and the unit switches to the next memory (factory settings).
h 1	The unit switches instantly to the next memory when a bank or numbered pedal is pressed.

Saving a sound (memory write)

Here’s how to save the current knob settings to a memory.

NOTE

- If you turn off the power or switch to a different memory before you write the memory, the sound you created is lost.
- When you write a memory, the memory that is already at the save destination is lost.

1. Press the [WRITE] button.

The pedal indicator blinks.

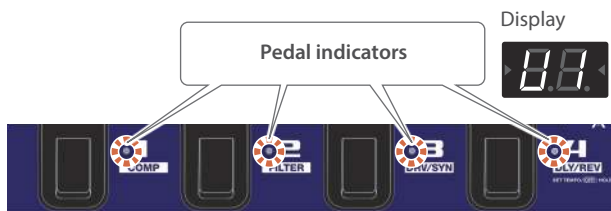

2. Select the user bank and memory number to save to (the save destination).

- Press the [BANK▼] [BANK▲] pedals to select the user bank number (U 1–U9).

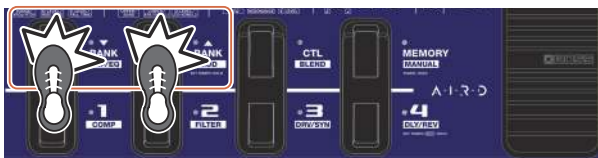

- Select the memory number by pressing the numbered [1]–[4] pedals.

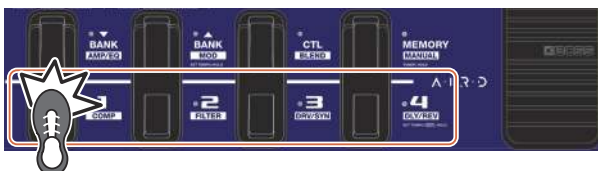

* To cancel memory write, press the [EXIT] button.

3. Press the [WRITE] button again.

All sound settings except for OUTPUT LEVEL are saved.

MEMO

- You can write memories in either manual mode or memory mode.
- Once you write a memory, the unit switches to memory mode.

Copying memories

To copy a memory, recall the memory (p. 6) and then write it.

You can copy the memory by selecting the copy destination memory number and then saving.

Changing the settings for sounds (memory edit mode)

You can’t switch the effects on/off in memory mode. If you want to switch the effects on/off or edit the sound (memory) settings, use memory edit mode.

1. Follow the steps in “Selecting a sound (memory)” (p. 6) to recall the memory whose settings you want to edit.

2. Press the [EDIT] button.

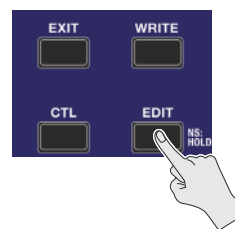

The display indicates “Ed”, and the unit switches to memory edit mode.

3. Use the knobs, pedals and buttons to edit the sound.

The pedal switches toggle the effects on/off in memory edit mode, just as with manual mode.

4. To save an edited sound, follow the steps in “Saving a sound (memory write)” (p. 7) to save the memory.

If you turn off the power or switch to a different memory before you write the memory, the sound you created is lost.

Useful functions

Adding effects that follow your tempo (tap tempo)

By pressing the pedal in time with the tempo you play at, you can set the delay to play back in time, in dotted eighth note or quarter note intervals.

MEMO

This explanation applies when you're in manual mode. In memory mode, use the numbered pedal for the currently selected memory to perform the same operation.

1. Set the DLY/REV type knob to "TEMPO".

The pedal indicator blinks in time with the delay time that's currently set.

2. Set the [TIME] knob to "♪" or "♩".

This selects the rhythm for the delay sound you want.



3. Press the [DLY/REV] pedal two or more times, in time with the tempo.

The delay timing is set according to the interval in which you press the pedal.

For instance, if you press the pedal in quarter note intervals, a dotted eighth note or quarter note delay time is set. The pedal indicator blinks in time with the tempo.

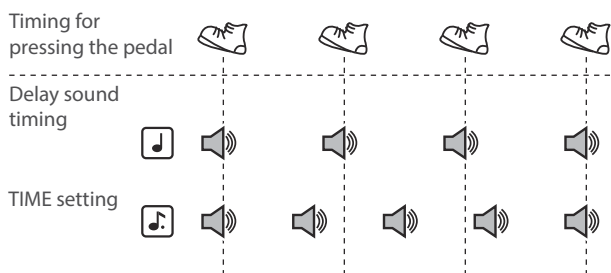

* To turn the delay off, press the [DLY/REV] pedal for two or more seconds.

Setting the modulation speed or delay time with the pedal

You can use the knob to adjust the modulation speed (cycle) or delay time, and you can use the pedal to set the timing you like.

MEMO

- This explanation applies when you're in manual mode. In memory mode, use the numbered pedal for the currently selected memory to perform the same operation.
- You can only set the delay time when the unit is in memory mode and both the MOD and DLY/REV effects are on.

1. Use the type knob to select the MOD or DLY/REV type.

MEMO

When using the MOD or DLY/REV effect and one of the following types is selected, you can't make settings using the pedal.

Effect	Types that cannot be selected with the pedal	
MOD	COMP	
	PRE EQ *1, POST EQ *1	
	OVERTONE *1	
DELAY	TERA ECHO	SHIMMER
	PHRASE LOOP	WARP *1
	ROOM	TWIST *1
	HALL	GLITCH *1
	PLATE	

*1 These effects can be selected from the ME-90B "BOSS TONE STUDIO for ME-90B" dedicated app (p. 13).

2. Hold down the [MOD] or [DLY/REV] pedal for two or more seconds.

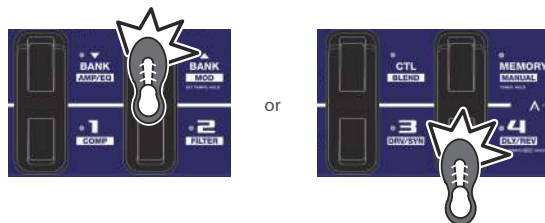

The pedal indicator starts blinking two seconds after you press the pedal.

3. Press the [MOD] or [DLY/REV] pedal two or more times at the desired speed.

The effect speed is set according to the interval at which you pressed the pedal.

The pedal indicator blinks in time with the modulation cycle or delay sound.

4. Hold down the [MOD] or [DLY/REV] pedal for two or more seconds again.

This completes the speed setting, and the effect turns on. The pedal indicator remains lit.

MEMO

If you move the [RATE] or [TIME] knob after finishing the settings, the effect timing you set with the pedal is disregarded, and the timing you set with the knobs is given priority.

Performing with phrase loops

You can record up to 38 seconds of a performance and play back the recorded section over and over. You can also layer additional performances with the recording as it plays back (overdubbing). This gives a unique effect if you keep playing what you recorded in the background and then play on top of that, for example.

MEMO

This explanation applies when you're in manual mode. In memory mode, use the numbered pedal for the currently selected memory to perform the same operation.

1. Set the DLY/REV type knob to "PHRASE LOOP".

The unit enters record standby mode, and the pedal indicator blinks white at a fixed interval.



2. Press the [DLY/REV] pedal.

Recording starts right when you press the [DLY/REV] pedal (the pedal indicator lights up red).



3. Press the [DLY/REV] pedal again.

Recording ends.

Once recording ends, your recorded content plays back in a loop (the pedal indicator lights up blue).

MEMO

The phrase loop may result in an oscillating sound if your recording is extremely short.

4. To overdub, repeat steps 2 and 3.

The pedal indicator lights up yellow during overdubbing.

MEMO

Your recorded content is erased when you change the type knob setting or turn the power off.

5. Use the [E. LEVEL] knob to adjust the playback volume.

6. To end loop playback, quickly press the [DLY/REV] pedal twice.

The unit returns to playback standby mode, and the pedal indicator blinks blue.

7. Press the [DLY/REV] pedal to start playback.

8. To erase what you recorded, long-press the [DLY/REV] pedal.

The pedal indicator blinks white, and the unit enters record standby mode.

MEMO

When you press the [DLY/REV] pedal twice, the second press must be within one second of the first.

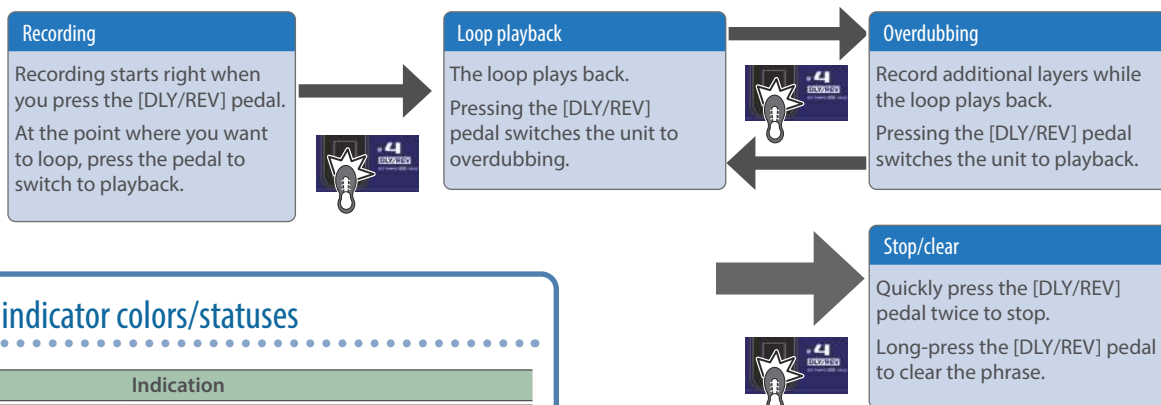

Configuring the [CTL] (control) pedal functions

In memory mode on the ME-90B, you can use the [CTL] pedal to turn multiple effects on/off at once, or instantly switch the value of a specified effect setting knob (one knob only) to a specific value. You can store the [CTL] pedal settings for each memory.

Setting the pedal function

1. Press the [MEMORY/MANUAL] pedal to switch to memory mode (p. 6).
2. Press the [CTL] button to switch to CTL setting mode.

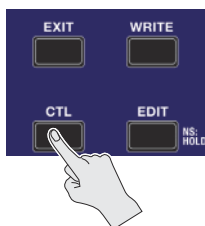

For turning the effects on/off

3. Press the pedal corresponding to the effect you want to toggle on/off to select it.



To cancel the selection, press the pedal again.

The pedal indicator for the effect you want to toggle on/off blinks.

MEMO

You can select BLEND to toggle the SEND/RETURN on/off, instead of using it for BLEND. For details, refer to “Configuring the device overall (system settings)” (p. 16).

For setting the value of a certain knob

3. Adjust the knob whose value you wish to change to the value you like.

To cancel the setting, set the [CTL] pedal to turn the effects on/off.

* You can't set the type knob values for the respective effects.

MEMO

You can press the [MEMORY/MANUAL] pedal to check the effects that you set before you write the memory.

To disable the [CTL] pedal function, turn all settings off.

4. Follow the steps in “Saving a sound (memory write)” (p. 7) to save the settings.

CTL setting mode indications

- If effects are configured to toggle on/off, “ E ” is shown in the display when the unit enters CTL setting mode, and the pedal indicators corresponding to the effects set for on/off blink.

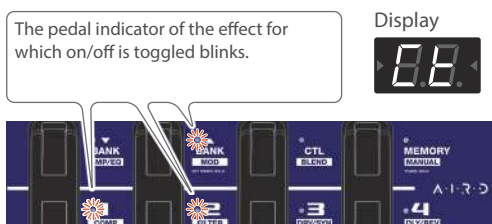

- When a particular knob value is set, the corresponding effect indicator blinks when you enter CTL setting mode. Also, “ E ” and the number of the knob for which the value is set are alternately shown in the display.

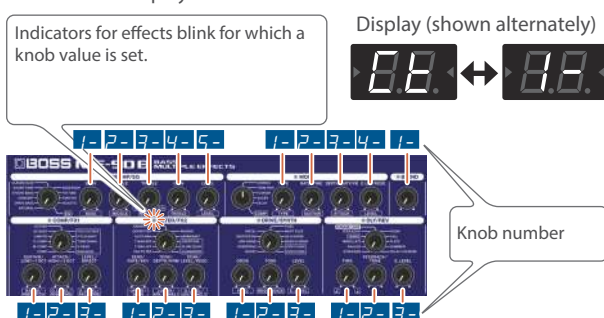

Configuring the pedal operations

You can select whether the effects you set in step 3 are toggled each time you press the pedal (TOGGLE), or whether the effects are only applied while the pedal is being pressed (MOMENTARY).

1. From memory mode, press the [CTL] button two times.
This switches to the TOGGLE/MOMENTARY setting mode.
2. Use the [BANK ▼] [BANK ▲] pedals to select a setting.

Display	Setting	Explanation
E o	TOGGLE	The effect switches each time you press the pedal (this is the default setting for effect on/off).
M o	MOMENTARY	The effect you set is applied only while you are pressing the pedal (this is the default setting when the pedal is set to change the knob values).

3. Press the [CTL] button again.
4. Follow the steps in “Saving a sound (memory write)” (p. 7) to save the settings.

MEMO

The indicator lit/unlit state for the [CTL] pedal is linked with the indicator of the effect that has the highest priority (according to the internal order of priority) within the effects that are toggled on/off.

The order of priority is as follows.

COMP/FX1 > FILTER/FX2 > DRIVE/SYNTH > DLY/REV > PREAMP/EQ > MOD > BLEND > PEDAL FX > SEND/RETURN

Connecting to and using an external effect unit via the SEND/RETURN jacks

You can connect an external effect unit between the SEND jack and RETURN jack, and use it as one of the ME-90B's effect units.

To do this, connect the SEND jack to output the ME-90B's sound to the input of your effect unit. Connect the output of the external effect unit to the RETURN jack (input) of the ME-90B.

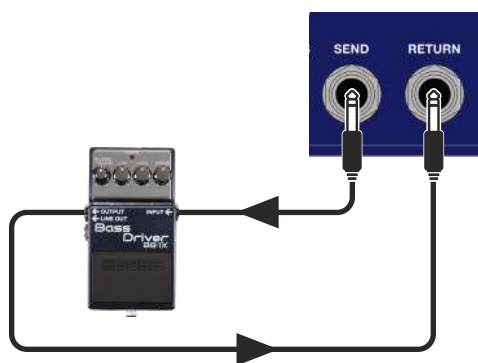

You can change the SEND/RETURN insertion point and the footswitch on/off function in the system settings (p. 16).

Using the factory setting, the SEND/RETURN is inserted before PREAMP in the signal chain, and is turned on.

If an external effect unit is not connected to the RETURN jack, no sound is output from the SEND jack.

MEMO

- Hold down the [EDIT] button and press the [CTL] pedal to toggle SEND/RETURN on/off.
- You can store the SEND/RETURN on/off state for each memory.

Display	Setting
□	Off
!	On

Calibrating the expression pedal

Although the ME-90B's expression pedal has been set for optimum operation at the factory, extended use and the operating environment can result in the pedal going out of adjustment.

If you experience issues such as the expression pedal switch not responding or not being able to fully minimize the sound with the volume pedal, calibrate the expression pedal.

1. Press the [MEMORY/MANUAL] pedal to switch to manual mode (p. 6).
2. Hold down the [DLY/REV] button and press the [DELAY] pedal.
The display indicates "Pd" → "LP".
3. Press down on the heel end of the expression pedal and take your foot off, and press the [WRITE] button.
"dn" is shown on the display.
4. Press the toe end of the expression pedal and take your foot off, and press the [WRITE] button.

The responsiveness (sensitivity) of the current expression pedal switch is shown in the display.

Value: 1–9

MEMO

If you press the [WRITE] button in steps 3 and 4 without fully pressing the pedal with your toes, the indication in the display blinks. If the display indication blinks, press the expression pedal down all the way and then press the [WRITE] button.

5. Use the [BANK▼] and [BANK▲] pedals to adjust the responsiveness (sensitivity) of the expression pedal switch.

Lower values make the pedal switch more responsive (lighter).

If you press down with your toes on the expression pedal, the PEDAL FX indicator lights up.

6. Press the [WRITE] button.

The settings are saved.

Connecting to your computer via USB

The ME-90B can transmit/receive digital audio signals and MIDI messages to and from a computer via USB.

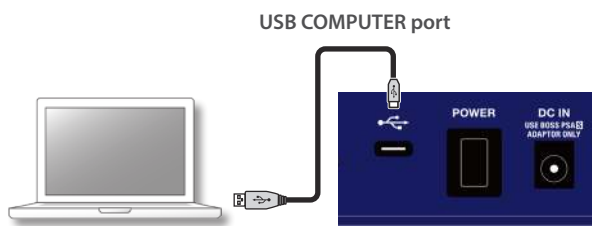

Installing the USB driver

You can use the dedicated driver to record, playback and edit audio with high quality at a stable timing, as well as control the ME-90B via MIDI data.

Download the dedicated ME-90B driver from the BOSS website (<https://www.boss.info/support/>).

Install the dedicated driver before making a USB connection.

The program you need to use and the steps you need to take to install the driver depend on your computer setup. Please carefully read and refer to the "Readme" file included with the download.

Transmitting/receiving audio signals between your computer and the ME-90B (USB audio)

You can use your computer to record the sound of the ME-90B, or output your computer's audio from the OUTPUT jacks, the PHONES jack and the BALANCED OUTPUT connector on the ME-90B.

You can select from two USB audio inputs ([INPUT] and [MIX IN]) and two outputs ([OUTPUT] and [DRY OUT]).

USB audio flow

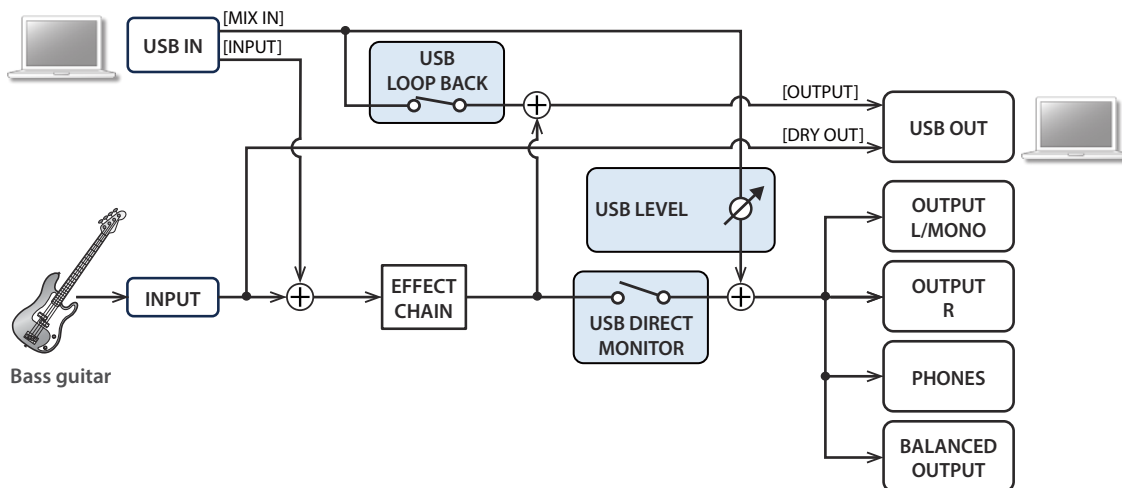

* Refer to the instruction manual for the software you are using to learn how to switch the input source of the software.

USB audio settings

You can change the audio signal flow to match your needs. For details on how to configure the settings, refer to "Configuring the device overall (system settings)" (p. 16).

Parameter	Explanation
USB LEVEL	Adjusts the level of audio input from your computer, which is mixed with the sound that passes through the ME-90B's effects.
USB DIRECT MONITOR	Selects whether the sound of the ME-90B is output from the OUTPUT jacks, the PHONES jack and the BALANCED OUTPUT connector.
USB LOOPBACK	Switches between outputting the input audio from the computer to USB OUT or not.

Transmitting/receiving MIDI data between a computer and the ME-90B (USB MIDI)

You can use DAW software on your computer or the ME-90B dedicated app to control the ME-90B, for editing sounds and managing memories.

Using the ME-90B dedicated app

The following operations are available from the “BOSS TONE STUDIO for ME-90B” dedicated app.

- Edit the settings for the user bank memories
- Give the user bank memories a name
- Reorder and swap the user bank memories
- Easily download memories from a memory download website
- Save the user bank memories and system settings as a backup, and restore the backup settings
- You can also select effects that are only available via the BOSS TONE STUDIO for ME-90B dedicated app.
- You can launch an IR loader to import IR (Impulse Response) data.

Download the dedicated app from the BOSS website (<https://www.boss.info/support/>).

Switching between memory numbers

The current memory on the ME-90B changes at the same time that this unit receives a program change message from DAW software or another source.

Receiving control change messages

This unit can receive control change messages to control specified parameters while you're playing.

Data that can be transmitted/received via MIDI

Pedal	Control change message	Value
Expression pedal	CC#11	0–127
Pedal effect on/off (EXP SW)	CC#82	On: 127 Off: 0
[CTL] pedal	CC#80	When the pedal is pressed: 127 When the pedal is released: 0

Loading IR data to use this unit as a speaker simulator

You can use the dedicated IR loader (software) to load IR (Impulse Response) data into this unit for simulating speakers.

The dedicated IR loader can be launched from the dedicated app, BOSS TONE STUDIO for ME-90B.

For details on how to load the data, refer to the “Using BOSS TONE STUDIO for ME-90B” (BOSS website).

You can select the speaker simulator by pressing the [1] [2] [3] [4] pedals while holding down the [EDIT] button.

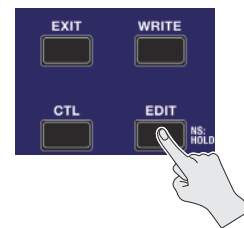

Press and hold

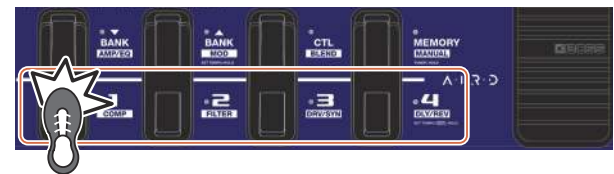

Pedal	Display	Speaker simulator
[1]	□	Uses the original speaker simulator built into the ME-90B, which is tuned to each preamp type (factory settings).
[2]	!	Uses the IR data loaded into USER 1.
[3]	2	Uses the IR data loaded into USER 2.
[4]	3	Uses the IR data loaded into USER 3.

* IR data is not included in USER 1–3 with the factory settings.

MEMO

You can select and store the speaker simulator for each memory. Set the [AMP/LINE] switch for the best output to match the output destination.

Wireless connection with a mobile device

Attach the **Bluetooth®** Audio MIDI Dual Adaptor (BT-DUAL, sold separately) to the ME-90B to wirelessly play back music from your mobile device, or to edit the effects of this unit from the dedicated app installed on your mobile device.

Attaching the BT-DUAL

Attach the BT-DUAL to the Bluetooth ADAPTOR jack of the ME-90B.

1. Before attaching the BT-DUAL, turn off the ME-90B and unplug the AC adaptor from the AC outlet.
2. Remove the cover and screw from the Bluetooth ADAPTOR jack on the rear panel.

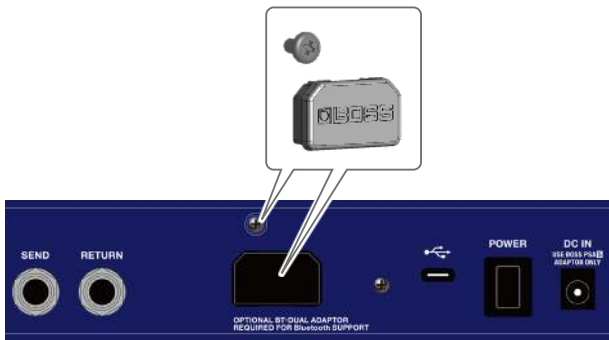

3. Attach the BT-DUAL and fasten the screw that you removed in step 2 in place.

Make sure that the screw hole on the ME-90B is aligned with the screw hole on the BT-DUAL when attaching.

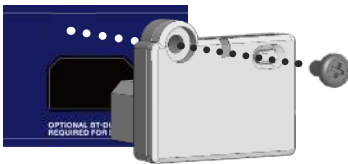

NOTE

- Be sure to use only the screw that was originally mounted on the Bluetooth ADAPTOR jack. If you use a different screw, the unit may malfunction.
- Do not touch any of the printed circuit pathways or connection terminals.
- When circuit board installation is complete, double-check your work.

Listening to sound via wireless connection with a mobile device

Bluetooth® audio functionality

You can output music played from your Bluetooth audio-capable mobile device from the OUTPUT jacks or the PHONES jack of the ME-90B.

This signal is not output to the BALANCED OUTPUT connector.

Registering a mobile device (pairing)

“Pairing” involves registering the mobile device that you want to use with the ME-90B (making the two devices recognize each other).

Here we’ll configure the settings so that music data saved on your mobile device can be played wirelessly via the ME-90B.

MEMO

The explanation below uses the iPhone as an example. For details, refer to the owner’s manual of your mobile device.

1. Turn on the power of the ME-90B.
2. Place the mobile device that you want to connect nearby the ME-90B.
3. Hold down the pairing button on the BT-DUAL until the Bluetooth indicator blinks rapidly.

Bluetooth indicator



4. Turn on the Bluetooth function of the mobile device.



5. Tap “ME-90B Audio” shown on the Bluetooth device screen of your mobile device.

This pairs the BT-DUAL with your mobile device.

When pairing succeeds, “ME-90B Audio” is added to the list of “MY DEVICES” on your mobile device.

- * If you don’t complete the pairing within a certain time, the Bluetooth indicator goes dark and the unit exits pairing standby mode.

Connecting an already-paired mobile device

1. With the BT-DUAL's Bluetooth indicator off, press the pairing button.
2. Turn on the Bluetooth function of the mobile device.



MEMO

- If you were unable to connect using the steps above, tap "ME-90B Audio", displayed in the Bluetooth device screen of the mobile device.
- To disconnect, press the pairing button on the BT-DUAL to make the Bluetooth indicator go dark, or turn off the mobile device's Bluetooth function.

Disabling Bluetooth functionality

If you want to disconnect the Bluetooth connection between the BT-DUAL and your mobile device, disable Bluetooth functionality. When this unit is not connected to the mobile device via Bluetooth, we recommend you turn off Bluetooth to save on battery power.

1. Press the pairing button on the BT-DUAL.

The Bluetooth indicator goes dark.

Controlling the ME-90B from the dedicated app on your mobile device

Use the dedicated BOSS TONE STUDIO for ME-90B app to edit effects and save this unit's settings.

For details on BOSS TONE STUDIO for ME-90B, refer to the BOSS website.

<https://www.boss.info/>

Connecting to the dedicated app

Here are the settings to make in order to use the dedicated app on your mobile device.

- * Make the connection from the dedicated app's settings screen, not from your mobile device's Bluetooth settings.

MEMO

The explanation below uses the iPhone as an example. For details, refer to the owner's manual of your mobile device.

1. Turn on the power of the ME-90B.
2. Place the mobile device that you want to connect nearby the ME-90B.
3. Turn on the Bluetooth function of the mobile device.



- * When Bluetooth audio is connected, the Bluetooth indicator on the BT-DUAL lights up. Note that the unit has not finished connecting with the dedicated app at this time.

4. In the dedicated app's settings, connect to "ME-90B MIDI".
- * Do not tap "ME-90B Audio", "ME-90B MIDI" or similar indications shown in the Bluetooth settings of your mobile device.

Operating the ME-90B wirelessly with an EV-1-WL/FS-1-WL

You can connect a wireless expression pedal (EV-1-WL) or a wireless footswitch (FS-1-WL) to this unit, both of which are sold separately.

Refer to the "EV-1-WL Connection Guide (Connecting to the ME-90B)" and the "FS-1-WL Connection Guide (Connecting to the ME-90B)", both on the BOSS website.

<https://www.boss.info/support/>

Configuring the device overall (system settings)

1. Press the [MEMORY/MANUAL] pedal to switch to manual mode (p. 6).
2. Press the [EDIT] button to select the parameter to set.
3. Use the [BANK ▼] [BANK ▲] pedals to select a value.
4. Press the [WRITE] button.
The settings are saved.

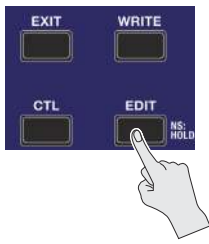

The parameter to set changes each time you press the [EDIT] or [CTL] button.

- [EDIT] button Selects the next parameter.
- [CTL] button Selects the previous parameter.

Parameter list

Parameter	Display	Explanation
OUTPUT SELECT	1-2	Specifies the amp that's connected to the OUTPUT jacks (p. 4).
Knob motion	n 0	The parameter value changes instantly when you operate the knobs (this is the factory setting).
	n 1	The value only changes once the knob position reaches the parameter's current value.
USB LEVEL	L 0-L 9	Adjusts the level of audio input from your computer, which is mixed with the sound that passes through the ME-90B's effects.
USB DIRECT MONITOR * Power-on setting is d 1	d 0	The sound of the ME-90B is not output from the OUTPUT jacks, the PHONES jack or the BALANCED OUTPUT connector.
	d 1	The sound of the ME-90B is output from the OUTPUT jacks, the PHONES jack and the BALANCED OUTPUT connector.
USB LOOPBACK	b 0	The input audio from the computer is not output via USB OUT.
	b 1	The input audio from the computer is output via USB OUT.
MIDI channels	C 1-C 9, C 0-C 6	ch 1-ch 9, ch 10-ch 16
Output settings when using the tuner	t 0	No audio is output when you're using the tuner.
	t 1	The direct sound is output while you're using the tuner.
Bank switch operation	h 0	Pressing the bank pedal to switch banks only changes the bank shown in the display, without actually switching to a different memory. Both the bank and number are confirmed right when you press a numbered pedal, and the unit switches to the next memory (factory settings).
	h 1	The memory switches instantly when a bank pedal or numbered pedal is pressed.

Parameter	Display	Explanation
Switching to manual mode	m 0	When you switch from memory mode to manual mode, the current knob settings are applied to the sound.
	m 1	When you switch from memory mode to manual mode, the memory settings are carried over (factory settings). The manual mode settings are retained when you switch from manual to memory mode.
SEND/RETURN insertion point setting	S 0	SEND/RETURN are inserted before the PREAMP/EQ in the signal chain. This is the optimal setting when using a distortion pedal or the like (factory settings).
	S 1	SEND/RETURN are inserted after the PREAMP/EQ in the signal chain. This is the optimal setting when using a delay pedal or the like.
Preserving/muting the effect sound when switching between memories or turning effects off	a 0	When you switch memories, the effect's delay/reverb sound you selected in DLY/REV is not carried over. This does not apply to the DELAY for MOD settings.
	a 1	When you switch memories, the effect's delay/reverb sound you selected in DLY/REV is carried over (factory settings). This does not apply to the DELAY for MOD settings.
LED illumination color	E 0	The LEDs can light up in one of ten colors (factory settings). The LEDs only light up to indicate their state in white and in color changes that are easy to distinguish (only red, yellow and blue).
	E 1	This mode is recommended for users with difficulties distinguishing colors or who prefer a classic-looking display.
BLEND footswitch functions	r 0	In manual mode, this turns BLEND on/off (factory settings).
	r 1	In manual mode, this turns SEND/RETURN on/off.

Restoring the factory settings (factory reset)

You can restore the settings of the ME-90B aside from the expression pedal calibration settings (p. 11) to their factory settings. This includes the user memories, reference pitch for the tuner, how the knobs respond and so on.

1. Press the [MEMORY/MANUAL] pedal to switch to manual mode (p. 6).
2. Hold down the [CTL] button and press the [DRV/SYN] pedal.



Press and hold

The display indicates "FR".

3. Press the [WRITE] button.

The tuning guide blinks.

4. Press the [WRITE] button again.

The display blinks, and the factory reset is executed.

* Never turn off the power while the factory reset is in progress.

Troubleshooting

Problem	Items to check	Cause/Action
Problems with sound		
No sound/insufficient volume	Is there a short in one of the connection cables?	Try replacing the connection cable.
	Is this unit properly connected to other devices?	Check the connections to other devices (p. 3).
	Is the power to the connected amp or mixer not turned on, or is the volume turned down?	Check the settings for connected devices.
	Might the [OUTPUT LEVEL] knob has been lowered?	Adjust the knobs to their appropriate positions (p. 4).
	Has the tuner been turned on?	Effects are not applied while tuning.
	Is the output setting set to $L \square$ when you are using the tuner?	Set this to " $d \square$ " (p. 16).
	Has each effect been configured correctly?	Check the settings for each effect.
	Is the "USB LEVEL" (p. 16) set too low?	Adjust the value as appropriate.
Sound from the device connected to the INPUT jack isn't coming through headphones	The batteries might be depleted.	Replace the batteries with new ones.
Sound from the device connected to the INPUT jack isn't coming through headphones	"USB DIRECT MONITOR" (p. 16) might have been set to " $d \square$ ".	Set this to " $d \square$ ".
Oscillating sound or feedback	The gain value or volume-related parameters in the effect settings might be set too high.	Try lowering these values.
Other problems		
Cannot switch between memories	The bank switch operation setting (p. 16) might be set to " $h \square$ ".	If the bank switch operation setting (p. 16) is " $h \square$ ", the memory does not actually change until you press a numbered [1]–[4] pedal.
Can't control the parameters as desired	Is the effect turned off?	If you are using the expression pedal or footswitches to operate the effects, check whether the effects that include the parameter you want to control are switched on.
	Do the MIDI controller numbers match?	Check whether the controller number you're using matches the number of the parameter to control (p. 13).
	The expression pedal might be miscalibrated.	Although the ME-90B's expression pedal has been set for optimum operation at the factory, extended use and the operating environment can result in the pedal going out of adjustment. Calibrate the expression pedal (p. 11).
Can't save a phrase you created using phrase loop	You can't save phrases you created using the phrase loop feature on the ME-90B.	
Can't connect to an Android device via Bluetooth	Location data on the Android device might have been turned off.	You may not be able to connect via Bluetooth if location data is turned off. Turn the Android device's location data setting on, and then try connecting again via Bluetooth.

Main specifications

Sampling Frequency	48 kHz
AD Conversion	24 bits + AF method * AF method (Adaptive Focus method) This is a proprietary method from Roland & BOSS that vastly improves the signal-to-noise (SN) ratio of the AD converters.
DA Conversion	32 bits
Processing	32-bit floating point
Effects	93 Types
Memories	36 (User) + 36 (Preset)
Phrase Loop	38 sec. (MONO)
Internal Tuning Detection Accuracy	±0.1 cent
Nominal Input Level	INPUT: -10 dBu RETURN: -10 dBu
Maximum Input Level	INPUT: +7 dBu RETURN: +7 dBu
Input Impedance	INPUT: 1 MΩ RETURN: 1 MΩ
Nominal Output Level	OUTPUT L/MONO, R: -10 dBu PHONES: -10 dBu SEND: -10 dBu BALANCED OUTPUT: -10 dBu
Output Impedance	OUTPUT L/MONO, R: 1 kΩ PHONES: 44 Ω SEND: 1 kΩ BALANCED OUTPUT: 600 Ω
Recommended Load Impedance	OUTPUT L/MONO, R: 10 kΩ or greater PHONES: 44 Ω or greater SEND: 10 kΩ or greater BALANCED OUTPUT: 600 Ω or greater
Display	7 segments, 2 characters (LED) Tuning guides (LED)
Connectors	INPUT jack, OUTPUT (L/MONO, R) jacks, SEND jack, RETURN jack: 1/4-inch phone type BALANCED OUTPUT jack: XLR type PHONES jack: Stereo miniature phone type USB COMPUTER port: USB Type-C® Bluetooth ADAPTOR connector: Dedicated connector DC IN jack
Power Supply	Alkaline battery (AA, LR6) x 4 AC adaptor
Current Draw	195 mA
Expected battery life under continuous use	Alkaline battery: Approximately 6 hours * This can vary depending on the specifications of the batteries, capacity of the batteries, and the conditions of use.
Dimensions	443 (W) x 220 (L) x 67 (H) mm 17-1/2 (W) x 8-11/16 (D) x 2-11/16 (H) inches Maximum height 443 (W) x 220 (D) x 93 (H) mm 17-1/2 (W) x 8-11/16 (D) x 3-11/16 (H) inches
Weight (including battery)	2.9 kg 6 lbs 7 oz
Accessories	Startup Guide Alkaline battery (AA, LR6) x 4 Leaflet "USING THE UNIT SAFELY"
Options (sold separately)	AC adaptor: PSA-S series Bluetooth® Audio MIDI Dual Adaptor: BT-DUAL Carry Bag: CB-ME80, CB-BU10

* 0 dBu = 0.775 Vrms

* This document explains the specifications of the product at the time that the document was issued. For the latest information, refer to the Roland website.