

BougeRV

User Manual

CIGS Thin-film Solar Panel

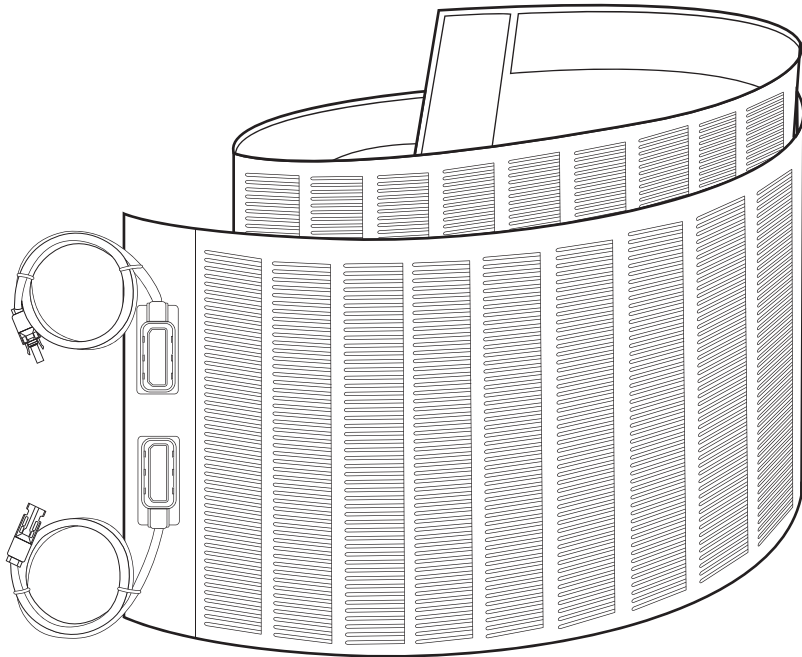

Features

CIGS solar cell, in full copper indium gallium selenide solar cell, thin-film photovoltaic device that uses semiconductor layers of copper indium gallium selenide (CIGS) to absorb sunlight and convert it into electricity.

- 1. Flexible** — Can fit around curved structures, flexible for all shapes.
- 2. Stable output** — Stable output can still be guaranteed in shadow occlusion environments.
- 3. Waterproof** — No worry about using in wet environments.
- 4. Lightweight** — No frames, no special stands or mounting brackets needed.
- 5. Glass Free** — Nothing to be broken.

CIGS Thin-film Modules vs. Polysilicon

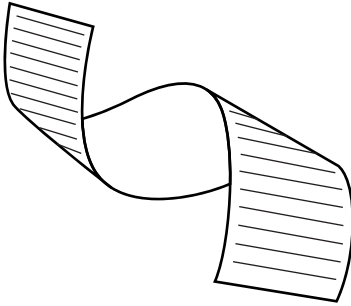

CIGS Thin-film Modules

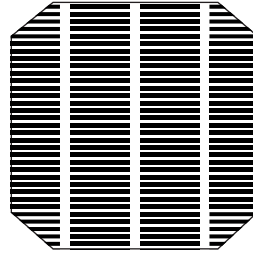

Polysilicon

Flexible

- Can fit around curved structures.
- Can be integrated into materials.

Durable

- Won't break / Resistant to vandalism.
- No risk of microcracks to cells.

Lightweight

- No retrofitting required.
- Can be used in applications such as consumer goods where weight is a concern.

Bonded Directly to Surface

- Lower installation costs.
- Resistant to theft.

Aesthetically Pleasing

- Uniform "black-tie" appearance.
- Dark interconnect wires.

Safer

- FLEX modules are lightweight-won't injure people or property in high wind or earthquake.
- No cell degradation at high voltage.
- No grounding wires to corrode.

Rigid

- Not bendable.
- Requires racking to install.

Breakable

- Can shatter.
- Cells can develop microcracks.

Heavy

- Roofs require reinforcement to support weight.

Requires Mounting Hardware

- Drives up installation costs.
- Subject to theft.

Clunky-looking

- Checkerboard appearance.
- Bulku paneling does not conform to the roof.

Dangerous in environmental emergencies

- Metal racks + box modules can damage people and property in an earthquake.
- Metal racks + box modules hazardous in the event of wind pull-off.

Solar Panel Dimension

Yuma100 Adhesive Dimension

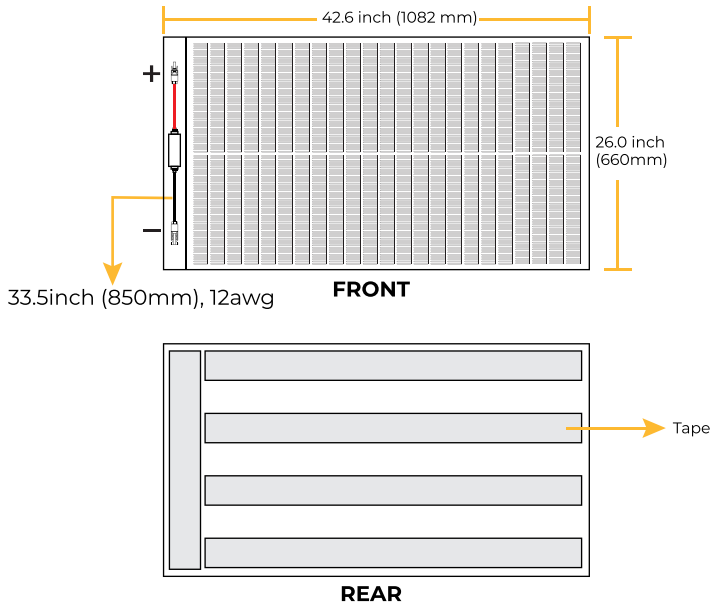

Yuma100 Drilled Dimension

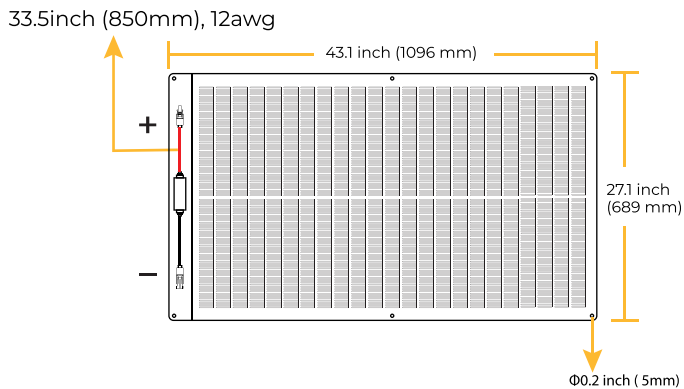

Yuma200 Adhesive Dimension

33.5inch (850mm), 12awg

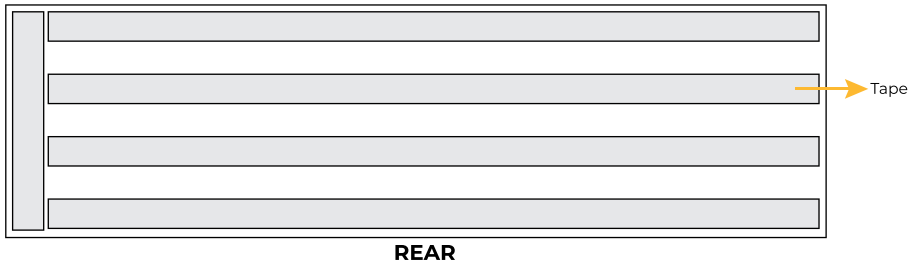
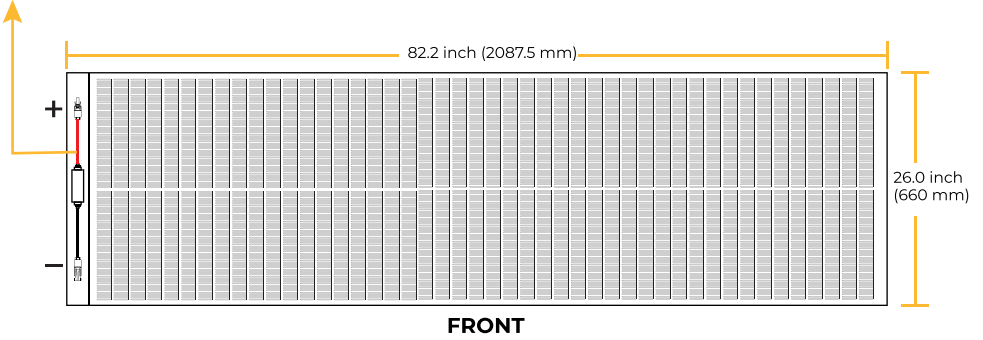

Yuma200 Drilled Dimension

33.5inch (850mm), 12awg

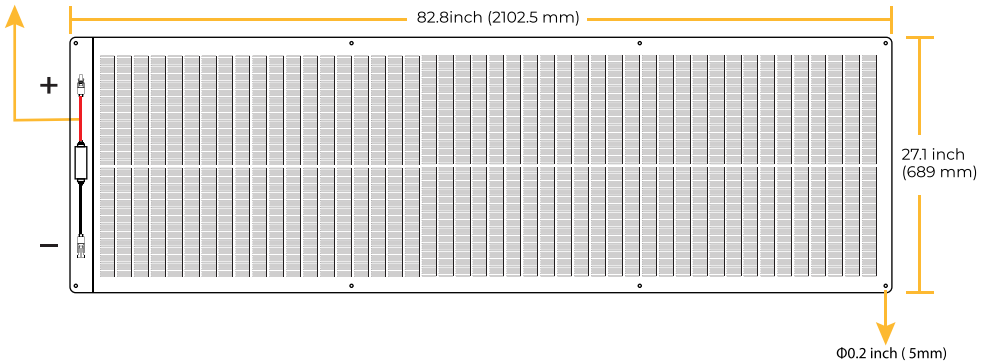

Yuma100L Adhesive Dimension

33.5inch (850mm), 12awg

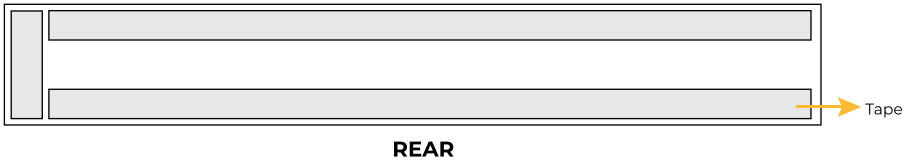
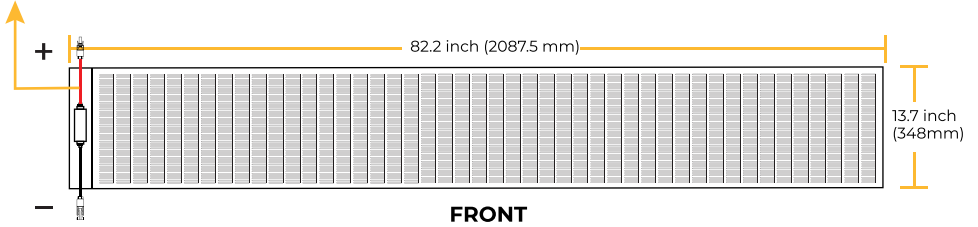

Yuma100L Drilled Dimension

33.5inch (850mm), 12awg

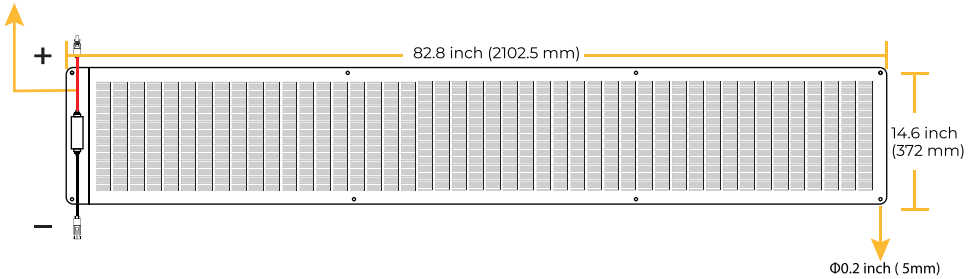

How To Use

1. Solar Off-grid System

(1) Peel off the protection tape in order.

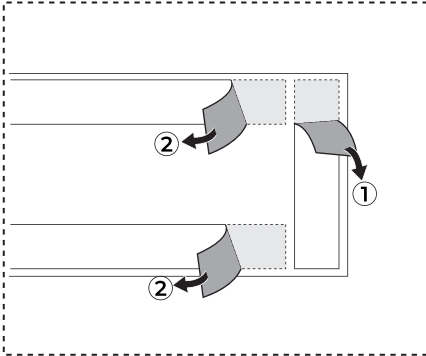

(2) Attach the solar panel to the ground.

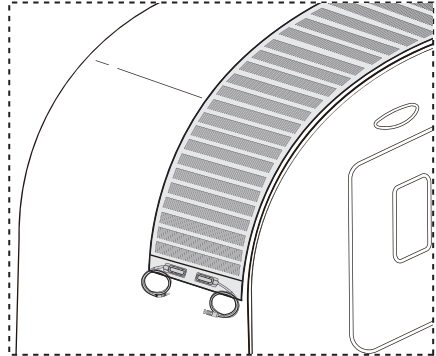

- First connect battery terminal wires to the charge controller.
- Then connect the solar panel to the charge controller.

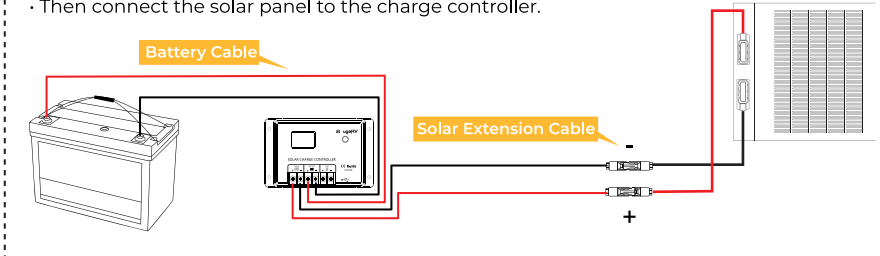

2. Solar Power Station System

Compatible with various types power stations

As long as your other cable is equipped with MC4 connectors, then it could connect with our connector of the solar panel.

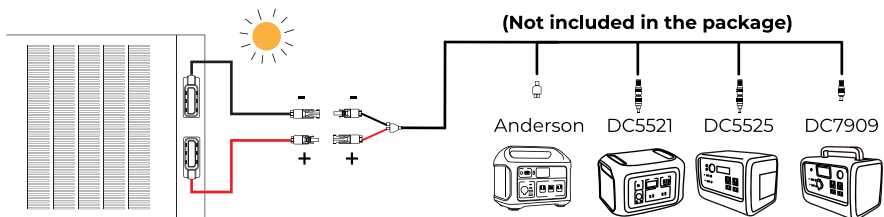

Note: Connecting the power station does not need connecting with the solar charge controller.

3. Series Connection

The panel can be wired in series to produce the desired voltage output.

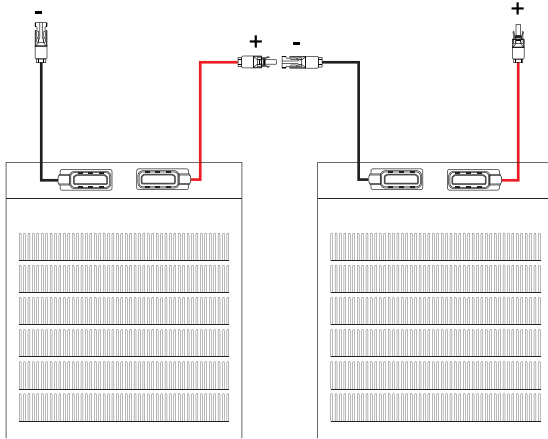

4. Parallel Connection

The solar panel can be wired in parallel to produce the desired current output with the solar parallel connector.

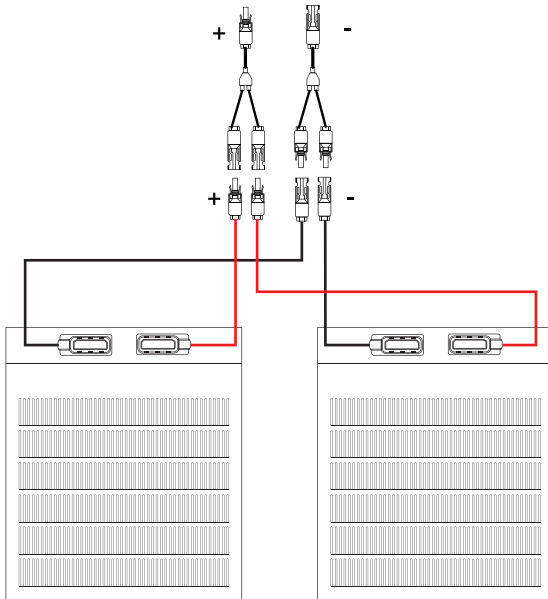

Electrical Parameters

Yuma100

	100W (Adhesive)	100W (Drilled)
Maximum Power (Pmax)	100W ±5%	100W ±5%
Solar cells Efficiency	17%	17%
Max. Power Voltage (Vmp)	24V ±5%	24V ±5%
Max. Power Current (Imp)	4.21A ±5%	4.21A ±5%
Open Circuit Voltage(Voc)	30.5V ±5%	30.5V ±5%
Short Circuit Current(Isc)	4.71A ±5%	4.71A ±5%
Max. System Voltage	1000V DC	1000V DC
Operating Temperature Limits	-40°F ~ +185°F -40°C ~ +85°C	-40°F ~ +185°F -40°C ~ +85°C
Temperature Coefficient of Pmax	-0.38%/°C	-0.38%/°C
Temperature Coefficient of Voc	-0.28%/°C	-0.28%/°C
Temperature Coefficient of Isc	-0.008%/°C	-0.008%/°C
Dimensions	82.2*13.7*0.06 inches 2087*348*1.5mm	82.8*14.6*0.06 inches 2102.5*372*1.5mm
Weight	4.63 lbs 2.1kg	3.46 lbs 1.57kg

Yuma200

	200W (Adhesive)	200W (Drilled)
Maximum Power (Pmax)	200W ±5%	200W ±5%
Solar cells Efficiency	17%	17%
Max. Power Voltage (Vmp)	24V ±5%	24V ±5%
Max. Power Current (Imp)	8.52A ±5%	8.52A ±5%
Open Circuit Voltage(Voc)	30.4V ±5%	30.4V ±5%
Short Circuit Current(Isc)	9.48A ±5%	9.48A ±5%
Max. System Voltage	1000V DC	1000V DC
Operating Temperature Limits	-40°F ~ +185°F -40°C ~ +85°C	-40°F ~ +185°F -40°C ~ +85°C
Temperature Coefficient of Pmax	-0.38%/°C	-0.38%/°C
Temperature Coefficient of Voc	-0.28%/°C	-0.28%/°C
Temperature Coefficient of Isc	-0.008%/°C	-0.008%/°C
Dimensions	82.2*26.0 inches 2087.5*660*1.5mm	82.8*27.1*0.06 inches 2102.5*689*1.5mm
Weight	8.44 lbs 3.83kg	5.95 lbs 2.7kg

Yuma100L

	100W (Adhesive)	100W (Drilled)
Maximum Power (Pmax)	100W ±5%	100W ±5%
Solar cells Efficiency	17%	17%
Max. Power Voltage (Vmp)	24V ±5%	24V ±5%
Max. Power Current (Imp)	4.21A ±5%	4.21A ±5%
Open Circuit Voltage(Voc)	30.5V ±5%	30.5V ±5%
Short Circuit Current(Isc)	4.71A ±5%	4.71A ±5%
Max. System Voltage	1000V DC	1000V DC
Operating Temperature Limits	-40°F ~ +185°F -40°C~+85°C	-40°F ~ +185°F -40°C~+85°C
Temperature Coefficient of Pmax	-0.38%/°C	-0.38%/°C
Temperature Coefficient of Voc	-0.28%/°C	-0.28%/°C
Temperature Coefficient of Isc	-0.008%/°C	-0.008%/°C
Dimensions	42.6*26.0*0.06 inches 1082*660*1.5mm	43.1*27.1*0.06 inches 1096*689*1.5mm
Weight	4.54 lbs 2.06kg	3.24 lbs 1.47kg

Frequently Asked Questions

Q1

What causes the low output power or no output during the use of solar panels? How can I solve it?

A1

1. Light intensity: Latitude, altitude, and sun altitude angle will affect the light intensity; multiple measurement results show that high temperature does not equal strong light intensity.

2. Solar installation angle: In the same geographical location, due to the different installation inclination angles, the cumulative amount of sunlight absorbed and the cumulative difference in radiation amount causes the difference in power generation. It works best when the solar panel is roughly perpendicular to the light.

3. Solar panel surface temperature: When the solar panel surface temperature is 77°F, the output power is ideal. When the temperature is higher than 77 degrees Fahrenheit, the output power will decrease.

4. Shadow occlusion: During the working process of the solar panel, due to the partial occlusion of the shadow and the different degrees of dust settlement, the pollution of bird droppings will cause the "hot spot effect", and the shaded part of the solar panel will not provide power contribution and will not be used in the solar panel. The interior becomes an energy-consuming load, and at the same time causes the local temperature of the solar panel to increase. The overheated area can cause the EVA to accelerate aging and turn yellow, which reduces the light transmittance of the area, further deteriorates the hot spot, and leads to aggravated failure of the solar panel. Therefore, when using it, you should avoid blocking things and clean the surface of the solar panel regularly.

5. Load factors: When charging the energy storage, it will be limited by the maximum PV input current and voltage of the energy storage. Therefore, the input power value displayed on the energy storage display does not represent the maximum output of the solar panel. Please confirm the PV input related parameters of the energy storage before use;

Due to the own characteristics of PWM, there is a certain switching loss in the process of connecting with the solar panel, so the input power obtained by the battery will be lower than the maximum output of the solar panel.

Q2

Why the solar panel can't provide 100% of the output energy?

A2

- 1. Limited by light intensity.** Please refer to **Q1** for more details.
- 2. Limited by the solar charge controller.** The output conversion efficiency of the PWM controller is 75%, and the output conversion efficiency of the MPPT controller is above 90%.
- 3. Limited by the power station.** The PV input voltage and PV input current of the power station will limit the output of the solar panel. It'd be better to confirm the input parameters of the power station before building a solar panel system.

Q3

What should I do if the solar panel I received is damaged, missing parts, or has no output?

A3

Please send relevant pictures to our after-sales mailbox **service@bouger.com** immediately, and leave your order number. We will reply one by one according to the chronological order sent by the customers.

Q4

What kind of device can be charged by this solar panel?

A4

- Solar Power Station
 - Lead-acid Battery (need the solar charge controller)
 - Lithium Battery (need the solar charge controller)
- BougerRV sells different kinds of MPPT/PWM controllers, lithium iron phosphate battery and power stations to build your solar system.**

Q5

How do I need to install this solar panel?

A5

Tear off the protection tape behind the solar panel, and then stick the solar panel to the ground.

Q6

How should I roll my rollable solar panel?

A6

Always roll the Rollable Solar Panel solar side out. Rolling solar side in will damage the panel and affect performance.

BougeRV

- Make The Journey -