

RCD 234DAB-BT

Manual

· ENGLISH ·

Specifications

GENERAL

Operating Power.....	12 Volts DC, Negative Ground
Speaker output.....	4 speakers
RCA line out.....	low-level outputs - 1V
Output Impedance.....	4 to 8 Ohms
Fuses.....	10 A
Dimensions.....	178mm(W) x 178mm(D) x 51mm (H)
Weight.....	2.0 Kg

CD PLAYER

Signal / Noise Ratio.....	>80dB
Frequency Response.....	20 Hz~20KHz
Channel Separation.....	>50dB
D / A Converter.....	16 Bit

FM TUNER

Tuning Range.....	(USA) - 87.5 - 107.9MHz, (Europe) - 87.5 - 108 MHz
FM Sensitivity.....	12dBu
Stereo Separation @ 1 KHz.....	35dB

AM TUNER

Tuning Range.....	(USA) -- 530-1710 KHz, (Europe) -- 522-1620 KHz
AM Sensitivity.....	30dBu

Precautions

- This unit will only play the following discs.

Type of disc	Label on the disc	Recorded material	Size of disc
CD, MP3, WMA		Audio only	12 cm

DO NOT ATTEMPT TO MODIFY THE UNIT, MODIFYING THE UNIT MAY CAUSE AN ACCIDENT.
 STOP THE VEHICLE BEFORE CARRYING OUT ANY OPERATION THAT COULD INTERFERE WITH YOUR DRIVING.
 DO NOT TURN ON THE UNIT IF THE TEMPERATURE INSIDE THE VEHICLE IS OUT OF -20°C TO 60°C.

This unit only reads 12 cm discs.

Don't attempt to modify the unit; it could result in an accident.

Stop the vehicle before any manipulation which could interfere with your driving.
 Do not use the unit if the temperatures are extremely cold or extremely high (lower than -20° or higher than +60°).

To enjoy a sound of best quality, handle discs as indicated below:

Clean the discs with a cleaning cloth.
 Clean each disc from the center to the outside edge.



Don't use CDs with blobs of glue or ink on its surface.



Don't use Cds with label or stickers on its surface.

There could be some remainder of glue which would interfere with the good performance of the unit if labels were starting to be rubbed away.



Hold and handle discs by the edges to keep the disc clean and don't touch its surface.



Warnings Before Installation

Important Warnings to Take Note of BEFORE Commencing Installation

Damage Caused By Incorrect Installation or Usage is NOT Covered By Warranty. PLEASE Take The Time To Read The Installation Notes Carefully.

- **To avoid shorts in your vehicles electrical system, be sure to disconnect the battery cable before beginning installation.**
- This unit is intended for vehicles with a 12-volt battery and negative grounding. Before installing the unit in a recreational vehicle, truck, or bus, check that the battery voltage is 12 volts.
- **Remove the two transport screws from the top of the unit before installation.**
- **The black lead is ground.** A good chassis ground requires a tight connection to ground. The area should be free from rust, paint or any form of dirt. Please ground this lead separately from the ground of high-current products such as power amps. If you ground the products together and the ground becomes detached, there is a risk of damage to the products or fire.
- Be sure to connect the colour coded leads according to the diagram. Incorrect connections may cause the unit to malfunction or damage the vehicle's electrical system. Cords for this product and those for other products may be different colours even if they have the same function. When connecting this product to another product, refer to the supplied installation manuals of both products and connect cords that have the same function.
- Be sure to connect the negative (-) speaker leads to the negative (-) speaker terminal. Never connect the negative (-) speaker leads to chassis ground.
- The unit is only designed for use with 4 speakers. Do not combine outputs for use with 2 speakers. Do not ground negative speaker leads to the chassis ground.
- Speakers connected to this unit must be high-power units with a minimum rating of 45W and impedance of 4 to 8 ohms. Connecting speakers with output and/or impedance values other than those noted here will result in damage to the head unit and the speakers. Check the condition of your speakers carefully-connecting this unit to old or degraded speakers may result in a fault which will damage the audio IC and invalidate the warranty.

Warnings Before Installation

- If this unit is installed in a vehicle that does not have an ACC (accessory) position on the ignition switch, the red lead of the unit should be connected to a terminal coupled with ignition switch ON/Off operations. If this is not done, the vehicle battery may be drained when you are away from the vehicle for several hours.
- Secure the wiring with cable clamps or adhesive tape. To protect the wiring, wrap adhesive tape around them where they lie against metal parts. To avoid short-circuiting, cover all disconnected lead with insulating tape. There is a possibility of short-circuiting if the leads are not insulated.
- Route and secure all wiring so it cannot touch any moving parts, such as the gear lever and handbrake. Do not route wiring in places that get hot, such as near the heater outlet. If the insulation of the wiring melts or gets torn, there is a danger of the wiring short-circuiting to the vehicle's body.
- Don't pass the yellow lead through a hole into the engine compartment to connect to the battery. This will damage the lead's insulation and cause a very dangerous short.
- Do not shorten any leads. If you do, the protection circuit may fail to work when it should.
- Never feed power to other equipment by cutting the insulation of the power supply lead of the unit and tapping into the lead. The current capacity of the lead will be exceeded, causing overheating.
- When this product's source is switched ON, a control signal is outputted through the orange lead. Connect to an external power amp's system remote control or the car's Auto-antenna relay control terminal (max. 300mA 12 V DC). If the car features a glass antenna, connect to the antenna booster power supply terminal.
- When an external power amp is being used with this system, do not connect the orange lead to the amp's power terminal. Likewise, do not connect the orange lead to the power terminal of the auto-antenna. Such connection could cause excessive current drain and a major malfunction. Refer to the relevant owner's manual for details on connecting the power amp and other units, then make the connections correctly.
- Do not block any vents or heater panels. Blocking them will cause heat to build up and may result in fire.
- Make sure that the unit has a good chassis ground. A good ground connection will eliminate most electrical noise. A good chassis ground requires a tight connection to the vehicles metal chassis.

Warnings Before Installation

The area around the ground connection should be clean, bare metal without rust, paint, plastic or dirt for a good electrical connection.

- If noise is still experienced when the motor of the vehicle accelerates, a choke should be placed in line with the power to the unit. The installation company will know what is required.
- When replacing the fuse(s) the replacement must be of the same amperage as shown on the fuse holder. Never replace a fuse with another of a different value. If the fuse blows again please contact your installation company.
- Do not block vents or heater panels. Blocking them will cause heat to build up inside and may result in fire.
- Double check that all wiring and connections are correct before re-connecting the battery and turning on the unit.
- After completing the installation and before operating the unit, reconnect the battery, Then press the (RES) button with a pointed object, such as a ball-point pen to set the unit to its initial status. After pushing the button, wait a few seconds for the red light to flash.

Tools for Installation

- 2 removal wrenches are supplied for taking out the old unit and place with this brand name car radio. The following tools and supplies may also be needed for the installation:

Tools for Installation:

- Philips Screw-drivers
- Wire Stripper
- Wire Cutter
- Hammer
- Pencil
- Electrical Tape
- Electric Drill

Supplies for Installation:

- Machine Screws
- Crimp Connectors
- 14 Gauge Wire for Power Connections
- 14-16 Gauge Speaker Wires
- * The above are not supplied.

Before You Install

Automotive audio equipment installations can be troublesome at times, even to the most experienced of installation technicians. If you are not confident working with electrical wiring, removing and reinstalling interior panels, carpeting, dashboards or other components of your vehicle, please call your dealer in order to have the unit professionally installed.

IMPORTANT: Remove the two transport screws from the top of the unit before installing.

1. Remove the Old Unit from the Dashboard

1. Remove the outer trim frame.

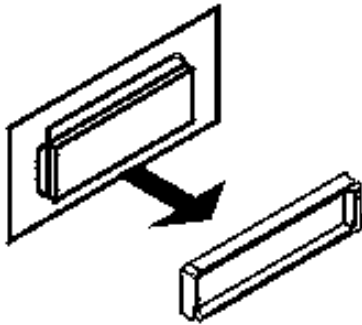

DIN Front Mount

2. Insert the keys supplied with the old unit into both sides of the unit as shown in figure below until they click. Pull to remove the old unit from the dashboard.

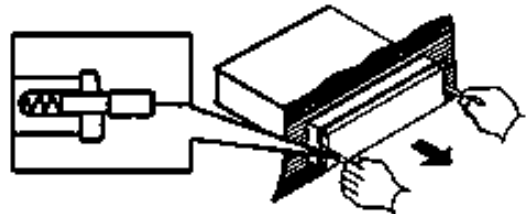

DO NOT DISCONNECT WIRES AT THIS TIME!

2. Mark Polarity of the Speaker Wires

Marking the polarity of the speaker wires will make it easier to connect the existing speakers to your car radio. Consult wiring diagram of existing head unit before disconnecting any wires. If you are not positive of the polarity of the existing wires from the speakers to the head unit, install new wires.

1. While the old unit is playing, disconnect the wires from one speaker
2. Take a length of masking tape and fold it around the wire so it forms a flag.
3. On the masking tape mark the polarity of the speaker wires (+ & -), as well as left or right, and front or rear.
4. Double check that you marked the first speaker correctly by checking that the speaker wires are the same at the head unit.
5. Repeat this procedure for all of the speakers.
6. Mark the power, ground, and any other wires also.

Installation

WARNING!

Disconnect negative battery terminal from battery before starting installation. Consult the vehicle's owner's manual for proper instructions.

NOTE: Mark the polarity of the existing speaker wires before disconnecting battery.

NOTE: Remove the two transport screws from the top of the unit before installing.

DIN Front Mount

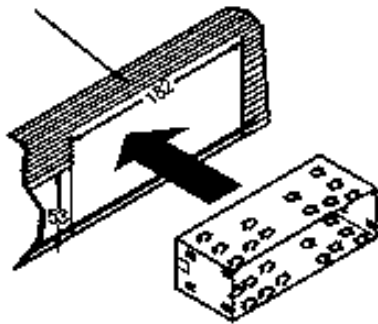

1. After removing the old radio and mounting sleeve, insert supplied mounting sleeve into opening.

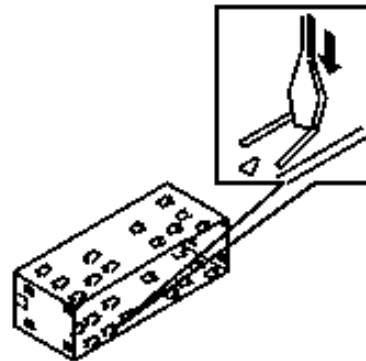

2. Bend the tabs on the mounting sleeve to keep the mounting sleeve firmly in place.

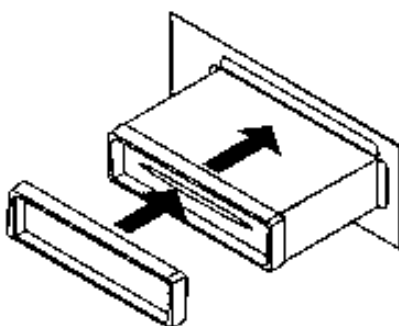

3. Attach wires from the unit to existing wires. See wiring connections diagram. Insert radio into dashboard. Then apply the trim frame to outside of radio.

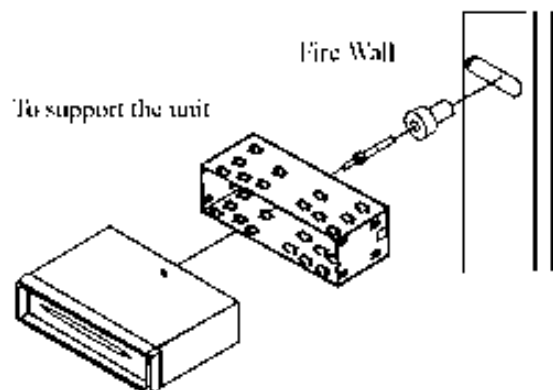

4. Support radio using supplied rear mounting bolt and steel bar. See parts list.

Installation

NOTE: Outer trim frame, hook, and mounting sleeve are not used for this installation.

This is only intended as a general guide; contact the vehicle's manufacturer for specific instructions.

This method of installation uses the screw holes at the sides of the unit and the holes of the existing vehicle mounting bracket.

1. Remove the hooks on both sides.
2. Align the screw holes of the mounting bracket supplied with the car and the screw holes of the main unit. Tighten the 2 screws on each side of the unit. Then fasten the brackets to the car.
3. Attach wires of the unit to existing speaker wires. See wiring diagram.

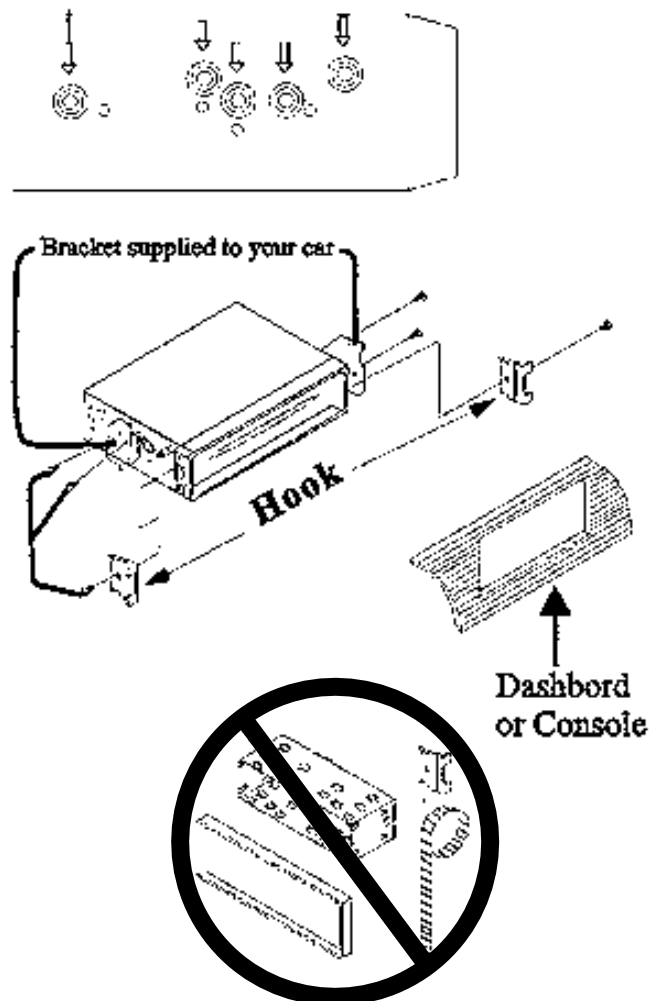

Wiring Connections

Make sure that you have a good chassis ground. Good ground connections will eliminate most electrical noise problems. A good chassis ground requires a tight connection to the vehicle's metal chassis. The area around the ground connection should be clean, bare metal without rust, paint, plastic, dust, or dirt for a good electrical connection.

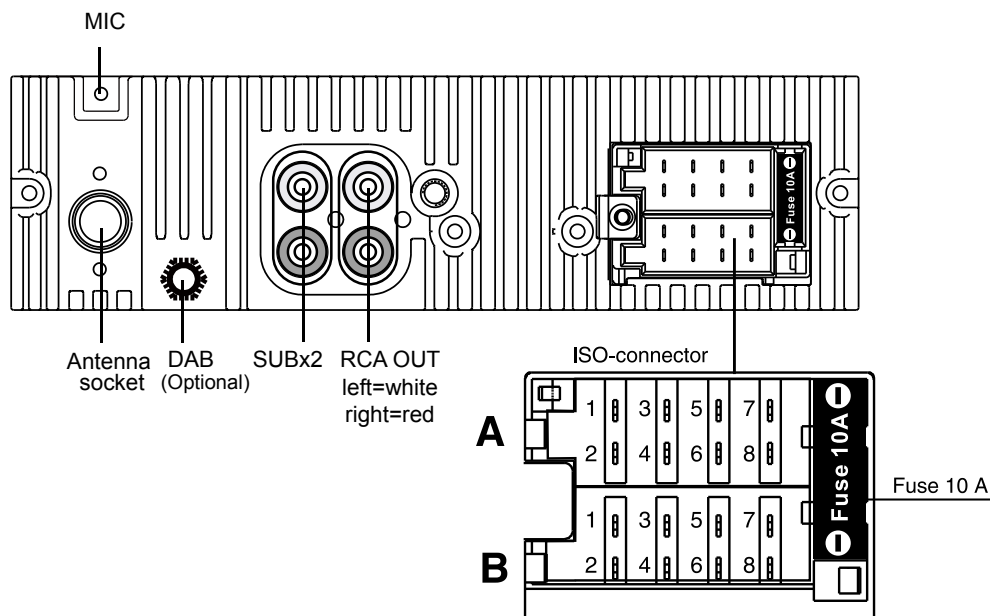

Connector A

1. Rear right speaker(+)/Purple
2. Rear right speaker(-)/Purple-Black
3. Front right speaker(+)/Grey
4. Front right speaker(-)/Grey-Black
5. Front left speaker(+)/White
6. Front left speaker(-)/White-Black
7. Rear left speaker(+)/Green
8. Rear left speaker(-)/Green-Black

Connector B

1. -
2. -
3. -
4. Battery 12V (+)/Yellow
5. Antenna power/Blue-White
6. Panel light/Orange-White
7. ACC+/Red
8. Ground/Black

Black Ground

Connect to vehicle body/chassis. Make sure that you have a good chassis ground. This will eliminate most electrical noise from the motor and alternator. A good chassis ground requires a tight connection to ground. The area should be free from rust, paint or any form of dirt.

Yellow Memory backup

Connect to electrical terminal always supplied with power regardless of ignition switch position.

Orange Remote

Connect to Auto-antenna or power amp control wire/remote connection. Maximum current 300Ma 12 V DC.(Low Current)

Wiring Connections

White Panel Light

Connect to lighting circuit of vehicle. This will illuminate the buttons on the display for night time operation. This wire can also be connected to the Orange Remote wire to activate the buttons when the unit is powered on. **DO NOT JOIN THE WHITE WIRE TO THE LIGHTING CIRCUIT OF THE VEHICLE IF CONNECTED TO THE ORANGE REMOTE WIRE.**

Speaker Wiring Notes

Follow the above wiring diagram to install the head unit with new or existing speakers.

- This unit is designed for use with four (4) speakers with impedance between 4 Ohms to 8 Ohms.
- An impedance load of less than 4 Ohms could damage the unit
- Never bridge or combine the speaker wire outputs. When not using four speakers, use electrical tape to tape the ends of the unused speaker outputs to prevent a short circuit.
- Never ground the negative speaker terminals to chassis ground.

Basic Operation

1. Tuning the unit On / Off

Press PWR Button to turn the unit on, the display will show a message WELCOME to indicate it is ready for use. Press and hold the PWR button to turn the unit off. The display will show a message "GOODBYE".

2. Mode Selection

Press the MOD Button to select Radio Mode. Press the MODE Button to cycle the Play Mode among AUX, RADIO and CD PLAY.

Note: USB & SD mode will only show on the display when a USB flash memory or SD card is inserted into the USB port or SD port.

3. Loudness Control

Press the SEL button until "LOUD OFF" is shown on the display indicates that the loudness function is OFF. Turn the volume knob to select between ON or OFF.

4. Mute Control

Press the POW/MUT button active or cancel Mute function.

5. Volume

Use the VOL +/- Button to adjust the volume level. The larger the number, the higher the volume level.

6. Treble

Press SEL Button repeatedly until the display shows "TRE 00". Use the VOL +/- Button to adjust. When EQ is ON, treble control is not available.

7. Balance

Press SEL Button repeatedly until the display shows "BAL L-R", then use the VOL +/- Button to adjust the balance between the left & right speakers.

8. Fader

Press SEL Button repeatedly until the display shows "FAD F-R", then use the VOL +/- Button to adjust the balance between the front & rear speakers.

9. Clock

The time clock can be set anytime when the power is on. Press the PTY/CLK Button on the faceplate or remote control once, the time will show on the display.

Then press and hold the button until the hour blinks on the display. Rotate the VOL knob to set hours, then press the VOL knob for the minutes to blink and rotate the VOL knob to set.

Press the PTY/CLK button again or leave the unit idle for new setting to effect. Press the PTY/CLK button anytime to view the time clock display.

10. Preset Beep Sound Off

Press the SEL button repeatedly until "BEEP ON" is displayed. Turn the VOL +/- Button to select "BEEP OFF" or "BEEP ON", then leave the unit idle for setting to take effect.

11. Preset Equalizer Function

Press the SEL Button repeatedly until "EQ" indication is displayed then rotate the Volume knob to choose between the EQ sound effects. The Sequence of equalizer setting will be as follows:

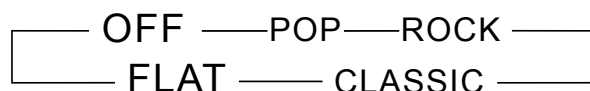

Radio Operation

1. Choose Radio Band

Press the BND Button anytime to access the radio function.

The unit comes with five bands- three FM Bands (FM1, FM2, and FM3) and two AM Bands (AM1, and AM2). Each of the five bands can store up to six preset stations, for a total of 30 preset memory stations.

2. Radio Tune / Seek Function

In Radio Mode, press and hold the ">>|" or "|<<", manual seek will be activated and the radio frequency will proceed by one step.

Press the SEEK |<< or >>| Button once, and the radio will seek the next strong and clear frequency station. Repeat to seek more stations in your listening area with a strong signal.

3. Mono / Stereo Reception Control

In FM radio mode, Press SEL Button repeatedly until the display shows 'MONO' or "STEREO". Rotate the Vol button to choose the reception control, the word "MONO" shown on the screen indicating the mono reception is received.

4. Save Your Preset Stations

There are six numbered preset buttons which can store and recall stations for each band. While listening to a radio station you would like to save as a pre-set, press and hold one of the buttons numbered 1-6 until the preset station number is shown. The button you pressed is now the pre-set button for that station.

5. Automatic Store / Preset Scan

A. Automatic Scan & Store

While listening to the FM Radio, press and hold the F/PS Button for 3 seconds. The receiver will automatically scan and save the station listening to.

While listening to the AM Radio, press and the F/PS Button for 3 seconds. The receiver will automatically scan and save the station you are listen-

ing to.

B. Scan Saved Stations

Press the F/PS button once to perform the scanning functions. In FM mode, press the F/PS button and the stations in that FM band will be scanned; press the button in AM mode and scan the band stations of that AM Band.

6. Local / DX

Press SEL Button repeatedly until the display shown "LOC". Rotate the VOL button to choose "LOC ON" or "LOC OFF".

a. "LOC ON" showing on the display, means local reception is turned on;

b. "LOC OFF" showing on the display, means distant reception is turned on. Local and distance reception setting can facilitate the radio reception, depending on the location in which the radio is being used.

7. DAB Function

This device is equipped with DAB function. Press MOD to cycle to DAB mode. Press F/PS to scan all the radio stations. When a station is listening, press BND to show the following information of the station:

- Name;
- Type;
- Code information;
- Frequency;
- Date;
- Signal strength.

Long press the Volume knob to show the DAB time synchronization with the system.

RDS Operation (Optional)

RDS Function

RDS (Radio Data System) service availability varies with areas. Please understand if RDS service is not available in you area, the following service is not available, either.

1. AF-ALTERNATIVE FREQUENCY

a. In RDS mode, press the AF button on the panel to turn the AF function on or off. When the Radio signal strength is poor, enabling the AF function will allow the unit to same PI (Program Identification) as the current station but with stronger signal strength, so that you do not have to retune the stations when driving between different transmitter coverage areas. When AF symbol is on, it means RDS information is received; when AF symbol is flashing, it means RDS information is not yet received. PS (Program Service name): the name of statin will be display instead of frequency.

If RDS service is not available in your area, turn off the AF mode. Dufault setting is ON.

b. In RBDS mode, no AF function.

2. TA - TRAFFIC ANOUCEMENT

Press and hold the TA button so that the unit will be activated for reception of traffic announcement from local radio stations.

To choose the TA mode, press the sound select button for 2 seconds, the display will show TA SEEK. Rotate the encoder volume to choose between the TA SEEK and TA ALARM, after chooisng, please leave the unit idle for the mode to activate. In TA SEEK mode, the unit will seek for traffic announcement programme when TA is pressed; in TA ALARM mode, no TA/TP is displayed and the alarm is set off.

3. PTY - PROGRAMME TYPE

This radio will allow you to select the type of programme required, and will search for a station broadcasting that

type of programme. Press and hold the PTY button once to show the music type. Then press 1-6 button to choose the different music types available.

Press the PTY button twice to show the speech type programme. Then press 1-6 button to choose the different speech type programme. Each number key will show 3 different speech programme for you to choose.

4. MASK DPI - MASK ALL

Press the sound select button for 2 seconds, the display will show TA SEEK. Press the sound select button again so that the unit will show MASK DPI. Rotate the encoder volume to toggle between MASK DPI and MASK ALL mode. Then leave the unit idle for the mode to take effect. During MASK DPI mode, the unit will mask only the AF which has different PI, this is the default mode; during MASK ALL mode, the unit will mask the AF which has different PI and no RDS signal with high field strength.

5. RETUNE S/L - SHORT/LONG

This function is to set the initial duration of automatic TA Search -- Press and hold the sound select button until "TA SEEK" is shown on the LCD, then press the SEL button to cycle through the menu selections until "RETUNE_S" is shown, use the VOL +/- button to choose "RETUNE_S" or "RETUNE_L". The default is "RETUNE_S".

6. TA VOL

This function is to set the TA volume, the default level is 25.

Bluetooth Operation

1. Pairing

The bluetooth of this radio is always in standby mode for pairing and connection, signalled by a blinking bluetooth icon on the LCD Display.

At this blinking time, please run the bluetooth search and connect function in your cellphone. The car radio model no "RCD234DBT Caliber" will be shown on the cellphone. Select this car radio and connect to finish the pairing. The bluetooth icon on the display will be on indicating that the connection is established.

Bluetooth function is ready to use.

* Pairing password is required in some phones. Insert "0000" in such case.

2. Calling

In any play mode, dial the desired number on your cellphone. The unit will switch to bluetooth handsfree mode automatically. "CALL OUT" will be shown on the display indicating the dialling is in progress.

3. Accepting Calls

When there is incoming call, "CALL IN" will be shown on the display indicating there is phone call to answer. "BT TALK" will be shown after the "ANSWER" button is pressed. Rotate the volume knob during ringing or conversation to adjust the respective volume level.

4. Rejecting Calls

During ringing or conversation, press the "REJECT" button to end the call or reject the call. the unit will resume to the original play mode.

5. BT Audio (A2DP)

Press MOD/  button until the unit entered BT AUDIO. BT audio will play automatically when you play the song in the cellphone. You could pause by "▶||" button, to choose previous or next song by pressing |<< and >>| button.

6. Disconnecting

Disconnect the paired phone by operating on the cellphone. You cannot process disconnection on the car radio headunit.

CD/MP3/WMA/USB/SD Operation

1. Insert / Eject CD

Insert a disc into CD slot with label side up. The disc will be automatically loaded into the unit, even when it is off or at radio mode. The word "LOAD" will blink on the display and the CD will play automatically. Press the EJECT Button to eject the disc from the slot. If the disc is not removed from the slot within 5 seconds, it will automatically be loaded into the slot again. When the disc is ejected and removed, the unit will automatically switch to radio mode.

While you are playing a disc with MP3 or WMA, The first file in the root folder will be played. if there is any ID3 information that will be displayed as the file is playing.

To play MP3/WMA files from a USB flash memory or SD card, insert a USB flash memory or SD card into the USB port or SD port of the unit. The unit will start playing MP3/WMA files on the USB flash memory automatically.

If the MP3/WMA files are stored in folders on the USB drive, the unit will start by playing the first song in the first folder. After playing all the files sequentially in the first folder, the unit will play sequentially all of the files in the next folder. The unit will continue playing through all of the folders on the USB drive in this manner.

If the USB drive has loose files and folders containing files, it will play the loose files sequentially, then it will play the files in the folders sequentially.

2. Multi-Session CD Reading

This unit can read multi-session CDs. The multi-session reading will be activated automatically if the player detects a file that is written in multi-session format.

3. Selecting Tracks

Press the SEEK >>| Button to advance CD to the next track. Track numbers will be shown on the display. Press

and hold SEEK >>| to fast forward. Press the SEEK |<< Button to go to a previous track. Track numbers will be shown on the display. Press and hold the SEEK |<< Button to fast reverse. Disc will play normally when the No. 1(play/pause) Button is pressed.

4. Play / Pause CD

Press the No.1/PAU Button to pause the CD. Press this button again to resume playback.

5. Scanning Tracks

Press the No.2/INT Button to play the first 10 seconds of each track, "INT" will be displayed on the display. Press this button again to resume playback.

6. Repeat

Press the No.3/RPT Button to repeat the current track. Press it again to cancel.

7. Random

Press the No.4/RDM Button to play all the tracks in random order. "RDM" will appear on the display. Press this button again to stop random play.

8. Folder Down

Press the "5 𠄎-" button once to go back one folder.

9. Folder UP

Press the "6 𠄎+" button once to advance one folder.

10. Search Modes

There are 3 search modes to help find your favorite MP3 & WMA tracks. The search modes only works with MP3/WMA CDs, and USB flash memory with MP3/WMA files.

A. Simple Track Search

Press the SEEK |<< or >>| Button to go to the next track or previous track.

B. Track Search

Press the F/PS Button, TRK-SCH will appear on the display. Use the VOL +/- Button to select the track number. press the SEL button so that the cho

CD/MP3/WMA/USB/SD Operation

sen track will start to play.

C. Folder Search

Press the F/PS Button twice and NAVIGATE will be shown on the display. Use the VOL +/- Button to select the folder name. Then press the SEL Button to play the chosen folder.

11. Electronic Skip Protection

Electronic Skip Protection is for driving on rough roads. The CD will play for 10 seconds on rough roads without skipping. If driving on a rough road for more than 10 seconds the CD may skip. For MP3 or WMA files will play for 60 seconds. If the road is rough for more than 60 seconds the CD with MP3 or WMA files may skip.

ID3 Tag

While you are playing an MP3 file which has ID3 Tag information, Press BND/ID3 button repeatedly to show the ID3 Tag information on the LCD. The ID3 Tag information will be as follows:
Fold - File - Title - Artist - Album

If there is no ID3 Tag information, nothing will be shown on LCD.

MAINTENANCE

Cleaning the Unit

Do not use any liquids to clean this unit.

Do not use petroleum distillates to clean this unit.

Use a clean, dry cloth to clean this unit.

Replacing the Fuse

Make sure the amperage matches the specified value when replacing the fuse(s). If the fuse is bad, check the power connection and replace the fuse with a new one. If the same problem occurs, this might indicate a malfunction within the unit.

Warning

When replacing a fuse, do not use a fuse with a higher amperage rating than the fuse originally supplied to your unit, otherwise damage will result to your unit.

Simple Troubleshooting Guide

PROBLEM	CAUSE/SOLUTION
No Power	Check and make sure that the fuses did not blow.
Errors are displayed on the screen or no function is active	Unplug your car radio then plug it again
No radio reception	Check the connection of the antenna. Make sure the antenna is completely extended and that it is not broken
CDs cannot be loaded	A CD is already inside the appliance. Make sure that the fixing screws of the CD mechanism have been removed.
The stereo indicator is blinking	Set the frequency more accurately. The reception signal is too low.

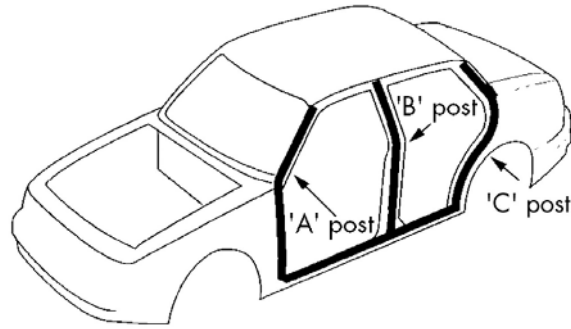

Place the antenna on the windshield near the 'A post'



Remove the cover of the A-post



Stick the transparent part of the antenna on the windshield and put the black part on the metal frame.

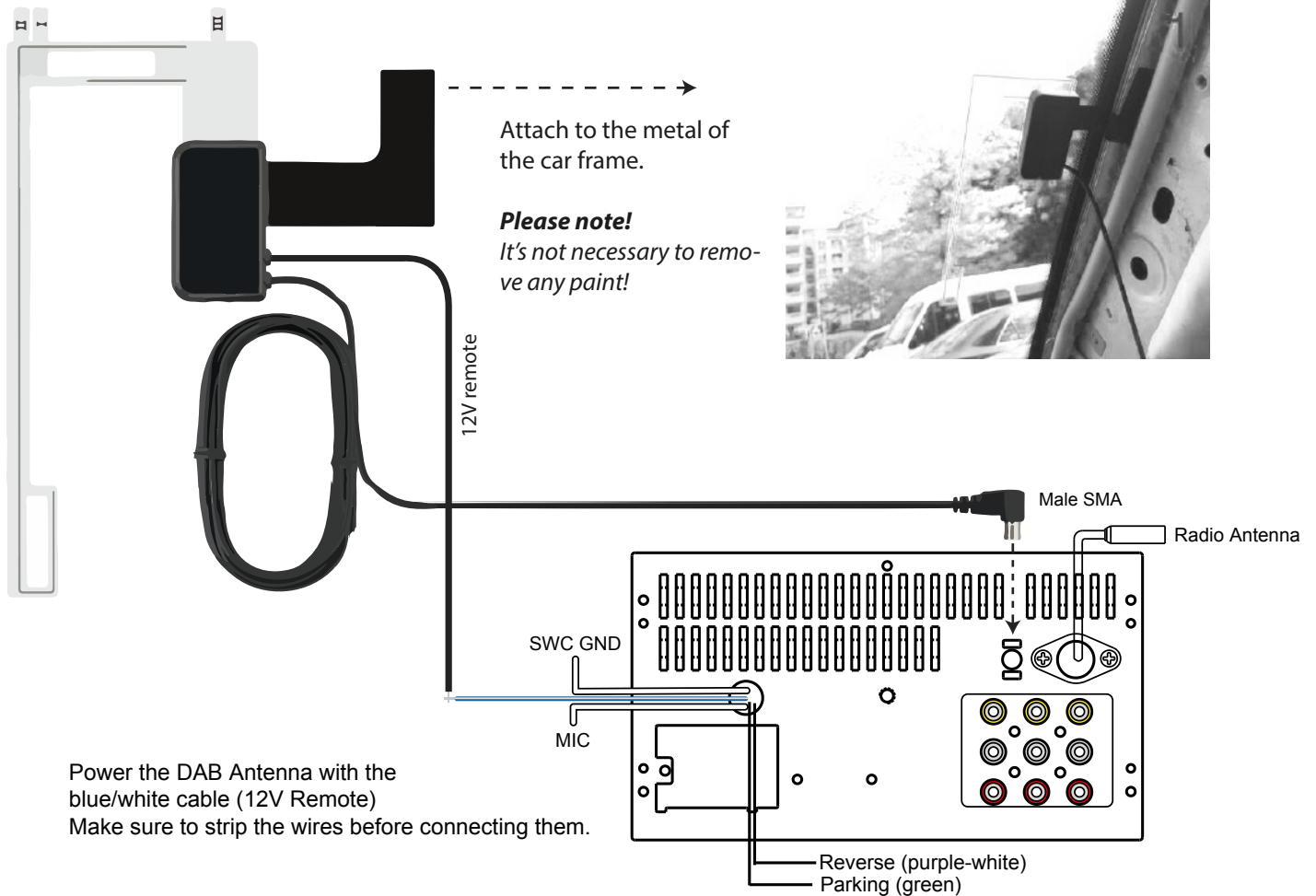

WWW.CALIBER.NL

CALIBER HEAD OFFICE · The Netherlands · Fax: +31 (0)416 69 90 01 · E-mail: info@caliber.nl