

14 SEER

Single-Packaged Air Conditioner and Gas Furnace System Tower Port Gas Valve Units (Not for use with propane)

Supplemental Instructions

NOTE: Read the entire instruction manual before starting the installation.

NOTE: This Instruction is for a temporary Gas Valve Substitution.

NOTE: This unit is for Natural Gas only. If planning to convert to LP/Propane, please contact distributor for replacement gas valve. The gas valve on this unit will not work with the propane conversion kit.

Please use the following instructions for checking inlet gas pressure, checking manifold pressure, and adjusting manifold pressure.

Check Inlet Gas Pressure

The inlet gas pressure must be checked with the furnace operating in gas heat mode. This is necessary to make sure the inlet gas supply pressure does not fall below the minimum pressure specified on rating plate.

1. Make sure the gas supply is turned off to the furnace and at the electric switch on the gas valve.
2. Loosen set screw on inlet tower pressure tap no more than one full turn with a 3/32-in. hex wrench. (See Fig. 2.)
3. Connect a manometer to the inlet pressure tap on gas valve using a 5/16" hose. (See Fig. 2.)
4. Turn on furnace power supply.
5. Turn gas supply manual shutoff valve to ON position.
6. Turn furnace gas valve switch to ON position.
7. Jumper R and W thermostat connections at the furnace control board.
8. When main burners ignite, confirm inlet gas pressure is within range specified on rating plate.
9. Remove jumper across thermostat connections to terminate call for heat. Wait until the blower off delay is completed.
10. Turn furnace gas valve electric switch to OFF position.
11. Turn gas supply manual shutoff valve to OFF position.
12. Turn off furnace power supply.
13. Remove manometer and hose from the inlet pressure tap of the gas valve. (See Fig. 2.)

WARNING

FIRE HAZARD

Failure to follow this warning could result in personal injury, death, and/or property damage.

Inlet pressure tap set screw must be tightened and 1/8--in. NPT pipe plug must be installed to prevent gas leaks.

14. Tighten set screw on inlet tower pressure tap with 3/32-in. hex wrench. (See Fig. 2.)

Adjust Gas Input

The gas input to the unit is determined by measuring the gas flow at the meter or by measuring the manifold pressure. Measuring the gas flow at the meter is recommended for natural gas units.

Measure Gas Flow (Natural Gas Units)

Minor adjustment to the gas flow can be made by changing the manifold pressure. The manifold pressure must be maintained between 3.2 and 3.8 IN. W.C.

If larger adjustments are required, change main burner orifices following the recommendations of national and local codes.

NOTE: All other appliances that use the same meter must be turned off when gas flow is measured at the meter.

Proceed as follows:

1. Turn off gas supply to unit.
2. There are 2 places to measure manifold and either may be used:
 - a. Remove pipe plug on manifold (See Fig. 1). Screw-in a 1/8" NPT brass hose barb and connect manometer by sliding connecting hose over the barb.
 - b. Loosen set screw on manifold tower pressure tap no more than one full turn with a 3/32-in. hex wrench. (See Fig. 2.) Connect manometer by sliding 5/6" connecting hose over the manifold tower pressure tap.

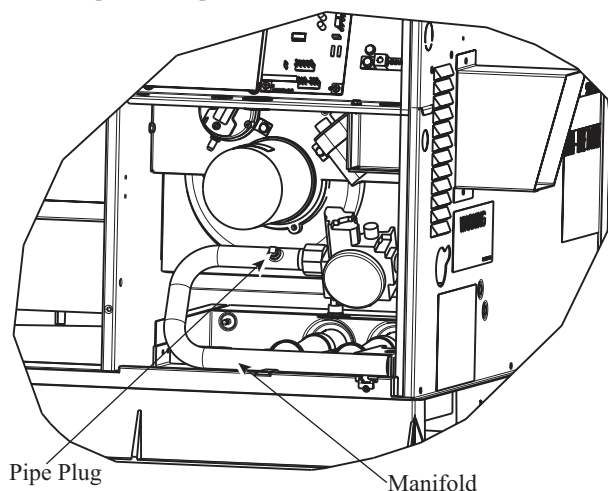

Fig. 1 – Burner Assembly

A07679

3. Turn on gas supply to unit.
4. Record number of seconds for gas meter test dial to make one revolution.
5. Divide number of seconds in Step 3 into 3600 (number of seconds in one hr).

6. Multiply result of Step 4 by the number of cubic feet (cu ft) shown for one revolution of test dial to obtain cubic feet (cu ft) of gas flow per hour.
7. Multiply result of Step 5 by Btu heating value of gas to obtain total measured input in Btuh. Compare this value with heating input shown in Table 1 (Consult the local gas supplier if the heating value of gas is not known).

EXAMPLE: Assume that the size of test dial is 1 cu ft, one revolution takes 32 sec, and the heating value of the gas is 1050 Btu/ft³. Proceed as follows:

1. 32 sec. to complete one revolution.
2. 3600 / 32 = 112.5.
3. 112.5 x 1 = 112.5 ft³ of gas flow/hr.
4. 112.5 x 1050 = 118,125 Btuh input.

If the desired gas input is 115,000 Btuh, only a minor change in the manifold pressure is required.

Observe manifold pressure and proceed as follows to adjust gas input:

1. Remove regulator cover screw over plastic adjustment screw on gas valve (see Fig. 2).
2. Turn plastic adjustment screw clockwise to increase gas input, or turn plastic adjustment screw counterclockwise to decrease input (see Fig. 2). Manifold pressure must be between 3.2 and 3.8 IN. WC.
3. Replace regulator cover screw on gas valve (see Fig. 2).
4. Turn off gas supply to unit.
5. Remove manometer from pressure tap:
 - a. If using a hoses barb on the manifold pipe, remove hoses barb and replace with pipe plug on the manifold (see Fig. 1).
 - b. If using the tower pressure port, remove connecting hose. Tighten set screw on manifold pressure tap using a 3/32" hex wrench. (See Fig. 2.)
6. Turn on gas to unit and check for leaks.

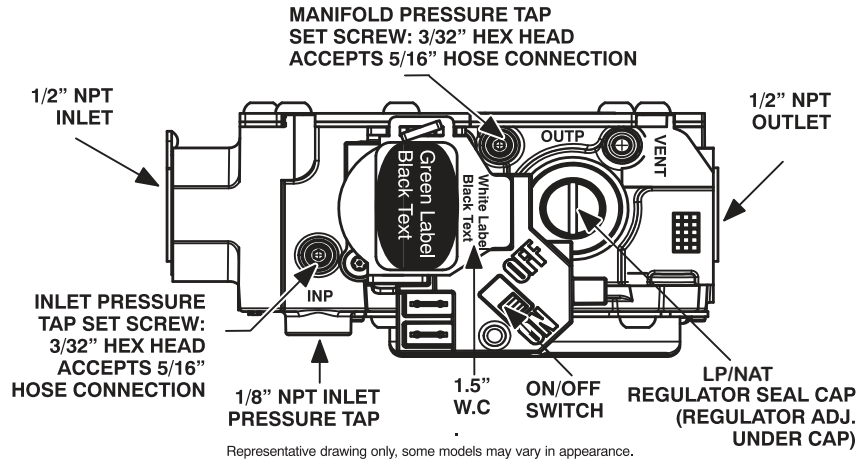

Fig. 2 – Low Capacity Gas Valve with Tower Pressure Ports

A170118

Table 1 – Heating Inputs

HEATING INPUT (BTUH)	NUMBER OF ORIFICES	GAS SUPPLY PRESSURE (IN. W.C.)				MANIFOLD PRESSURE (IN. W.C.)	
		Natural*		Propane*†		Natural{	Propane*†
		Min	Max	Min	Max		
40,000	2	4.0	13.0	11.0	13.0	3.2~3.8	10.0~11.0
60,000	3	4.0	13.0	11.0	13.0	3.2~3.8	10.0~11.0
90,000	3	4.5	13.0	11.0	13.0	3.2~3.8	10.0~11.0
115,000	3	4.5	13.0	11.0	13.0	3.2~3.8	10.0~11.0
130,000	3	4.5	13.0	11.0	13.0	3.2~3.8	10.0~11.0

*. Based on altitudes from sea level to 2000 ft (610 m) above sea level. In U.S.A. for altitudes above 2000 ft (610 m), reduce input rating 4 percent for each additional 1000 ft (305 m) above sea level. In Canada, from 2000 ft (610 m) above sea level to 4500 ft (1372 m) above sea level, derate the unit 10 percent.

†. When a unit is converted to propane, different size orifices must be used. See separate, natural-to-propane conversion kit instructions.