



Installation Instructions

SAFETY CONSIDERATIONS

Centrifugal liquid chillers are designed to provide safe and reliable service when operated within design specifications. When operating this equipment, use good judgment and safety precautions to avoid damage to equipment and property or injury to personnel.

Be sure you understand and follow the procedures and safety precautions contained in the chiller instructions, as well as those listed in this guide.

▲ DANGER

DO NOT VENT refrigerant relief device within a building. Outlet from rupture disc or relief valve must be vented outdoors in accordance with the latest edition of ASHRAE (American Society of Heating, Refrigeration and Air Conditioning Engineers) 15. The accumulation of refrigerant in an enclosed space can displace oxygen and cause asphyxiation.

PROVIDE adequate ventilation in accordance with ASHRAE 15, especially for enclosed and low overhead spaces. Inhalation of high concentrations of vapor is harmful and may cause heart irregularities, unconsciousness, or death. Intentional misuse can be fatal. Vapor is heavier than air and reduces the amount of oxygen available for breathing. Product causes eye and skin irritation. Decomposition products are hazardous.

DO NOT USE OXYGEN to purge lines or to pressurize a chiller for any purpose. Oxygen gas reacts violently with oil, grease, and other common substances.

DO NOT USE air to leak test. Use only refrigerant or dry nitrogen. NEVER EXCEED specified test pressures. VERIFY the allowable test pressure by checking the instruction literature and the design pressures on the equipment nameplate.

DO NOT VALVE OFF any safety device.

BE SURE that all pressure relief devices are properly installed and functioning before operating any chiller.

▲ WARNING

DO NOT WELD OR FLAME CUT any refrigerant line or vessel until all refrigerant (*liquid and vapor*) has been removed from chiller. Traces of vapor should be displaced with dry air or nitrogen and the work area should be well ventilated. *Refrigerant in contact with an open flame produces toxic gases.*

DO NOT USE eyebolts or eyebolt holes to rig chiller sections or the entire assembly.

DO NOT work on high-voltage equipment unless you are a qualified electrician.

DO NOT WORK ON electrical components, including control panels, switches, starters, or oil heater until you are sure ALL POWER IS OFF and no residual voltage can leak from capacitors or solid-state components.

LOCK OPEN AND TAG electrical circuits during servicing. IF WORK IS INTERRUPTED, confirm that all circuits are deenergized before resuming work.

AVOID SPILLING liquid refrigerant on skin or getting it into the eyes. USE SAFETY GOGGLES. Wash any spills from the skin with soap and water. If liquid refrigerant enters the eyes, IMMEDIATELY FLUSH EYES with water and consult a physician.

NEVER APPLY an open flame or live steam to a refrigerant cylinder. Dangerous over pressure can result. When it is necessary to heat refrigerant, use only warm (110 F [43 C]) water.

DO NOT REUSE disposable (nonreturnable) cylinders or attempt to refill them. It is DANGEROUS AND ILLEGAL. When cylinder is emptied, evacuate remaining gas pressure, loosen the collar, and unscrew and discard the valve stem. DO NOT INCINERATE.

CHECK THE REFRIGERANT TYPE before adding refrigerant to the chiller. The introduction of the wrong refrigerant can cause chiller damage or malfunction.

Operation of this equipment with refrigerants other than those cited herein should comply with ASHRAE 15 (latest edition). Contact Carrier for further information on use of this chiller with other refrigerants.

DO NOT ATTEMPT TO REMOVE fittings, covers, etc., while chiller is under pressure or while chiller is running. Be sure pressure is at 0 psig (0 kPa) before breaking any refrigerant connection.

CAREFULLY INSPECT all relief valves, rupture discs, and other relief devices AT LEAST ONCE A YEAR. If chiller operates in a corrosive atmosphere, inspect the devices at more frequent intervals.

DO NOT ATTEMPT TO REPAIR OR RECONDITION any relief valve when corrosion or build-up of foreign material (rust, dirt, scale, etc.) is found within the valve body or mechanism. Replace the valve.

DO NOT install relief devices in series or backwards.

USE CARE when working near or in line with a compressed spring. Sudden release of the spring can cause it and objects in its path to act as projectiles.

▲ CAUTION

DO NOT STEP on refrigerant lines. Broken lines can whip about, and release refrigerant, causing personal injury.

DO NOT climb over a chiller. Use platform, catwalk, or staging. Follow safe practices when using ladders.

USE MECHANICAL EQUIPMENT (crane, hoist, etc.) to lift or move inspection covers or other heavy components. Even if components are light, use mechanical equipment when there is a risk of slipping or losing your balance.

BE AWARE that certain automatic start arrangements CAN ENGAGE THE STARTER, TOWER FAN OR PUMPS. Open the disconnect *ahead* of the starter, tower fan, and pumps. Shut off the chiller or pump before servicing equipment.

USE only repaired or replacement parts that meet the code requirements of the original equipment.

DO NOT VENT OR DRAIN waterboxes containing industrial brines, liquid, gases, or semisolids without the permission of your process control group.

DO NOT LOOSEN waterbox cover bolts until the waterbox has been completely drained.

DOUBLE-CHECK that coupling nut wrenches, dial indicators, or other items have been removed before rotating any shafts.

DO NOT LOOSEN a packing gland nut before checking that the nut has a positive thread engagement.

PERIODICALLY INSPECT all valves, fittings, and piping for corrosion, rust, leaks, or damage.

PROVIDE A DRAIN connection in the vent line near each pressure relief device to prevent a build-up of condensate or rain water.

CONTENTS

	Page
SAFETY CONSIDERATIONS	1
INTRODUCTION	2
General	2
Job Data	2
Equipment Required	2
INSTALLATION	2-28
Receiving the Chiller	2
• INSPECT SHIPMENT	
• IDENTIFY CHILLER	
• PROVIDE CHILLER PROTECTION	
Rigging the Chiller	2
• RIG CHILLER ASSEMBLY	
• RIG CHILLER COMPONENTS	
• COMPONENT DISASSEMBLY	
Install Chiller Supports	12
• INSTALL STANDARD ISOLATION	
• INSTALL OPTIONAL ISOLATION	
• INSTALL SPRING ISOLATION	
Connect Piping	12
• INSTALL WATER PIPING TO HEAT EXCHANGERS	
• INSTALL WATER TO OIL COOLERS ON COMPRESSOR AND EXTERNAL GEAR	
• INSTALL VENT PIPING TO RELIEF DEVICES	
Make Electrical Connections	18
• CONNECT CONTROL INPUTS	
• CONNECT CONTROL OUTPUTS	
• CARRIER COMFORT NETWORK INTERFACE	
Install Field Insulation	26
• FACTORY INSULATION (Optional)	
INSTALLATION START-UP REQUEST CHECKLIST	CL-1,CL-2

INTRODUCTION

General — The 17EX chiller is factory assembled, wired, and leak tested. Installation consists primarily of establishing water and electrical services to the chiller. The rigging, installation, field wiring, field piping, and insulation are the responsibility of the contractor and/or customer. See Fig. 1 for model number information.

The 17EX chiller can be used to chill water or brine. The data in this manual applies to either application. Applications using corrosive brines may require special tubing, tube sheet, and waterbox materials which are special order items.

Job Data

Necessary information consists of:

- job contract or specifications
- chiller location prints
- rigging information
- piping prints and details
- field wiring drawings
- starter manufacturer's installation details
- Carrier certified drawings

Equipment Required

- mechanic's tools (refrigeration)
- volt-ohmmeter and clamp-on ammeter
- leak detector (halide or electronic)
- absolute pressure manometer or wet-bulb vacuum indicator
- portable vacuum pumps

INSTALLATION

Receiving the Chiller

INSPECT SHIPMENT

⚠ CAUTION

Do not open any valves or loosen any connections. The standard 17EX chiller may be shipped with a nitrogen holding charge or with the refrigerant charge isolated within the economizer/storage vessel.

1. Inspect for shipping damage while chiller is still on shipping conveyance. If chiller appears to be damaged or has been torn loose from its anchorage, have it examined by transportation inspectors before removal. Forward claim papers directly to transportation company. *Manufacturer is not responsible for any damage incurred in transit.*
2. Check all items against shipping list. Immediately notify the nearest Carrier representative if any item is missing.
3. To prevent loss or damage, leave all parts in original packages until beginning installation. All openings are closed with covers or plugs to prevent dirt and debris from entering the chiller's components during shipping. A full operating oil charge is placed in the oil sump of the compressor before shipment.

IDENTIFY CHILLER — The chiller model number (Fig. 1), serial number, and heat exchanger sizes are stamped on chiller identification nameplate. Check this information against shipping papers and job data.

PROVIDE CHILLER PROTECTION — Protect chiller and starter from construction dirt and moisture. Keep protective shipping covers in place until chiller is ready for installation.

If chiller is exposed to freezing temperatures after water circuits have been installed, open waterbox drains and remove all water from cooler and condenser. Leave drains open until system is filled.

Rigging the Chiller — The 17EX chiller can be rigged as an entire assembly. It also has flanged connections that allow the compressor, economizer/storage vessel, motor, external gear, cooler, and condenser sections to be separated for ease of installation. Figure 2 shows the 17EX components.

RIG CHILLER ASSEMBLY — See rigging instructions on label attached to chiller. Also refer to the rigging information found in Fig. 2-5 and Tables 1-10. *Lift chiller only from the 4 points indicated in rigging guide.* Each lifting cable or chain must be capable of supporting the entire weight of the chiller.

⚠ WARNING

Lifting chiller from points other than those specified may result in serious damage to the unit and personal injury. Rigging equipment and procedures must be adequate for chiller weight. See Table 1 for chiller weights.

NOTE: These weights are broken down into component sections for use when installing the unit in sections. For the complete chiller weight, add all component sections and refrigerant charge together. Total chiller weight is also stenciled on the cooler and condenser sections.

Copy continued on page 5.

	17EX	47	47	583	J	FH	66	1	-	
Model Description 17EX — Open Drive Centrifugal Liquid Chiller										Special Order Code - — Standard S — Special Order
Cooler Size* 45-48										Waterbox Code 1 — Marine Waterbox Cooler/ Marine Waterbox Condenser 2 — Marine Waterbox Cooler/ NIH Waterbox Condenser 3 — NIH Waterbox Cooler/ Marine Waterbox Condenser 4 — NIH Waterbox Cooler/ NIH Waterbox Condenser
Condenser Size 45-47 55-57										Motor Voltage 64 — 2400-3-60 53 — 3000-3-50 65 — 3300-3-60 54 — 3300-3-50 66 — 4160-3-60 55 — 6300-3-50 67 — 6900-3-60
Compressor Size 531 through 599										Motor Size FA FF HA HF JA JF FB FG HB HG JB JG FC FH HC HH JC JH FD FJ HD HJ JD JJ FK HK JK
Gear Code G (60 Hz) P (50 Hz) J (60 Hz) S (50 Hz) L (50 and 60 Hz) N (50 and 60 Hz)										

LEGEND

NIH — Nozzle-In-Head

*Any available cooler size can be combined with any available condenser size.

NOTE: For details on motor size designations, see below.

	F	A	
Open Drive Motor Type F — ODP (Open Drip Proof) H — WP11 (Weather Protected, Type II) J — TEWAC (Totally Enclosed Water-to-Air Cooled)			Motor Horsepower (kW)
			hp (kW) S.F. (Service Factor)
			A — 1250 (932) 1.15
			B — 1500 (1119) 1.15
			C — 1750 (1305) 1.15
			D — 2000 (1492) 1.15
			F — 1250 (932) 1.05
			G — 1500 (1119) 1.05
			H — 1600 (1194) 1.05
			J — 1750 (1305) 1.05
			K — 2000 (1492) 1.05



Fig. 1 — Model Number Identification

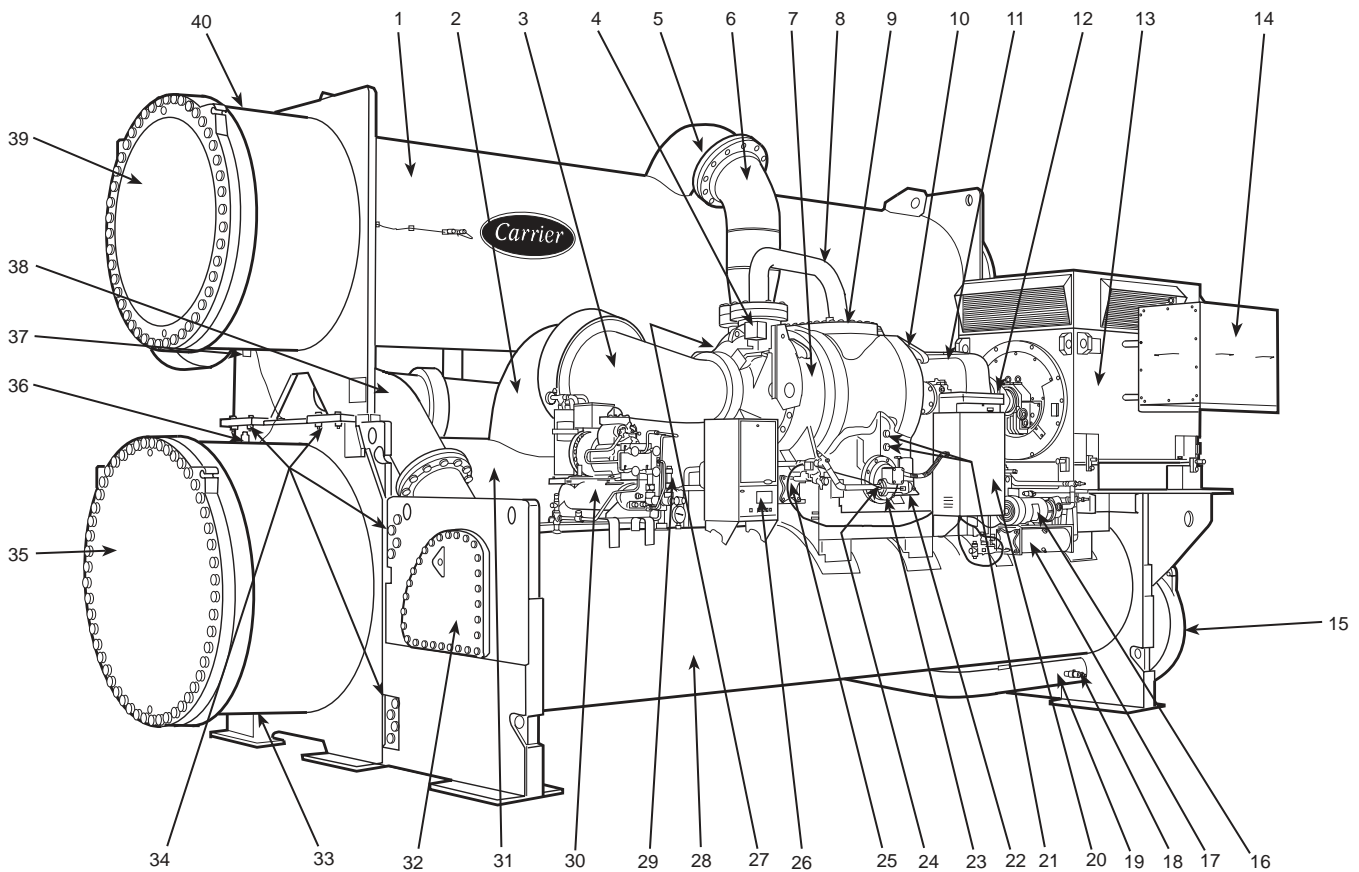

LEGEND

- | | |
|---|---|
| 1 — Condenser | 22 — Oil Drain and Charging Valve |
| 2 — Cooler Suction Pipe | 23 — Oil Heater (Hidden) |
| 3 — Compressor Suction Elbow | 24 — Compressor Oil Pump |
| 4 — Guide Vane Actuator | 25 — Compressor Oil Cooler/Filter |
| 5 — Condenser Discharge Pipe | 26 — Local Interface Display Control Panel |
| 6 — Compressor Discharge Elbow | 27 — Cooler Relief Valves (Behind Compressor, Hidden) |
| 7 — Two-Stage Compressor | 28 — Economizer Storage Vessel |
| 8 — Economizer Gas Line to Compressor | 29 — Economizer/Storage Vessel Relief Valves |
| 9 — Compressor Housing Access Cover | 30 — Pumpout Unit |
| 10 — High-Speed Coupling (Hidden) | 31 — Cooler |
| 11 — External Gear (Speed Increaser) | 32 — High Side Float Box Cover |
| 12 — Low-Speed Coupling (Hidden) | 33 — Cooler Waterbox Drain |
| 13 — Open-Drive Compressor Motor | 34 — Take-Apart Connections |
| 14 — Compressor Motor Terminal Box | 35 — Cooler Marine Waterbox |
| 15 — Low-Side Float Box Cover | 36 — Cooler Waterbox Vent |
| 16 — Gear Oil Pump | 37 — Condenser Waterbox Drain |
| 17 — Gear Oil Cooler/Filter | 38 — Refrigerant Liquid Line to Economizer/Storage Vessel |
| 18 — Refrigerant Charging/Service Valve | 39 — Condenser Marine Waterbox |
| 19 — Refrigerant Liquid Line to Cooler | 40 — Condenser Waterbox Vent |
| 20 — Power Panel | |
| 21 — Oil Level Sight Glasses (2) | |

17EX WITH EXTERNAL GEAR (SPEED INCREASER)

Fig. 2 — Typical 17EX Chiller Components

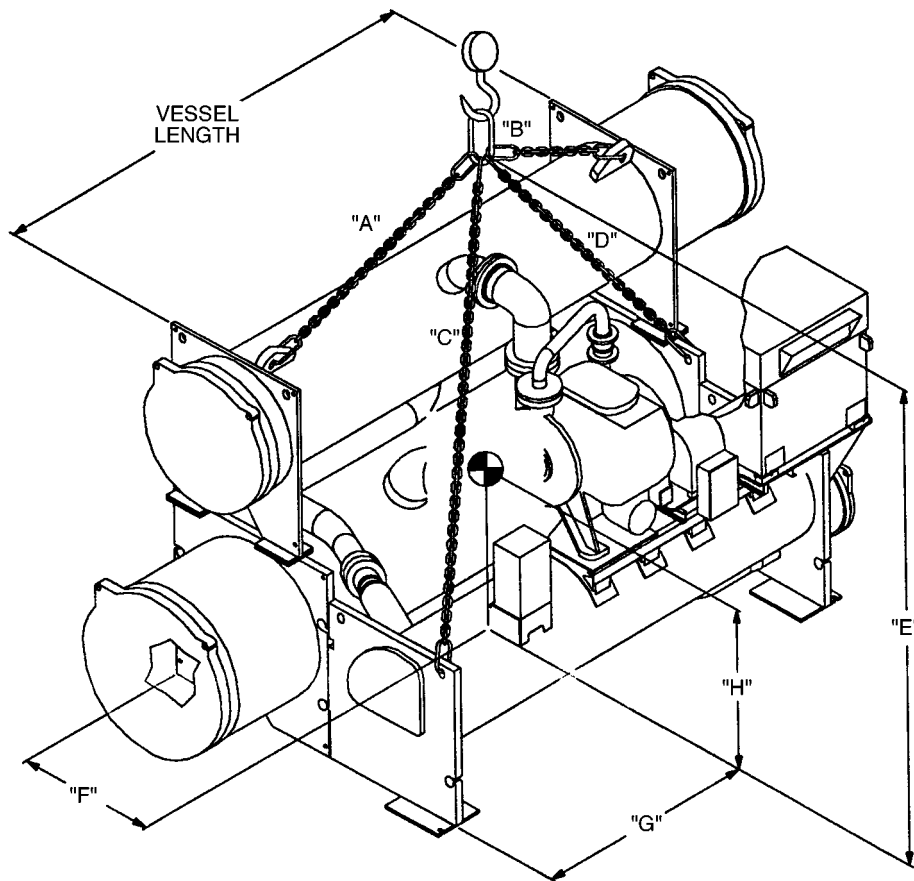

COOLER SIZE	VESSEL LENGTH		MAXIMUM WEIGHT		LIFTING ANGLE	CHAIN LENGTH								LIFTING HEIGHT FROM FLOOR "E"		CENTER OF GRAVITY APPROXIMATE LOCATION					
	ft-in.	mm	lb	kg		"A"		"B"		"C"		"D"		ft-in.	mm	"F"		"G"		"H"	
						ft-in.	mm	ft-in.	mm	ft-in.	mm	ft-in.	mm			ft-in.	mm	ft-in.	mm	ft-in.	mm
45-48	17-0	5182	93,450	42,389	30°	10-9	3277	8-7	2616	16-6	5029	13-0	3962	16-11	5136	4-3	1295	9-7	2921	5-5	1651
					45°	13-1	3988	11-2	3404	19-6	5944	16-3	4953	20- 8	6299						
					60°	18-4	5588	16-8	5080	25-2	7671	22-2	6756	27- 3	8306						

- NOTES:
1. Each chain must be capable of supporting the maximum weight of the machine.
 2. Maximum weight of machine includes refrigerant in storage vessel. (Max 4800 lb)
 3. = Approximate center of gravity.

Fig. 3 — 17EX Rigging Guide

RIG CHILLER COMPONENTS — Refer to instructions on page 6, Fig. 2-5, and Carrier certified drawings for chiller component disassembly.

IMPORTANT: Only a qualified service technician should disassemble and reassemble the chiller. After reassembly, the chiller must be dehydrated and leak tested.

⚠ WARNING

When rigging components separately, the open drive motor and gear must be removed to avoid overturning.

⚠ WARNING

Do not attempt to disconnect flanges while the chiller is under pressure. Failure to relieve pressure can result in personal injury or damage to the unit.

⚠ CAUTION

Before rigging any chiller component (e.g., compressor, gear, etc.), disconnect the wires leading from the power panel to the control center at the power panel.

NOTE: Wiring for sensors must be disconnected. Label each wire before removal (see Carrier certified drawings).

Detach all transducer and sensor wires at the sensor, then clip all wire ties necessary to remove the wires from the heat exchangers.

COMPONENT DISASSEMBLY

Separate Compressor from the Chiller

1. Make sure that the chiller is at atmospheric pressure before disassembly.
2. Since the center of gravity on the 17EX economizer/storage vessel is high, the motor and external gear MUST be removed before rigging the economizer/storage vessel.
3. The suction elbow should be rigged separately (Fig. 4, Item 2). Place slings around the elbow and attach them to the hoist. Remove the bolts at the flanges, (Fig. 4, Items 1 and 3). Detach and remove the elbow.
4. Remove the high speed coupling guard (Fig. 4, Item 8). Remove the high speed coupling (Fig. 4, Item 9). Be sure to keep the high speed coupling hardware with the high speed coupling after it is disassembled.
5. Unbolt the discharge flange to the condenser (Fig. 4, Item 5). Cut any copper lines connecting the compressor to the cooler, condenser, or the economizer/storage vessel. This includes the compressor vent line to the cooler (hidden).
6. Disconnect and detach the economizer/storage vessel vent line (Fig. 4, Item 6). Unbolt the line at the flanges (Fig. 4, Items 4 and 7).
7. Disconnect the wiring to the control center and power panel.
8. Connect the rigging to the compressor, unbolt the compressor from the base (Item 16), and hoist it off the chiller. If the compressor is to be transported or set down, its base should be bolted to sections of 4 in. x 6 in. lumber.

Separate the Motor from the Chiller

1. Remove the low speed coupling guard (Fig. 4, Item 11). Remove the low speed coupling (Fig. 4, Item 12). Be sure to keep the low speed coupling hardware with the low speed coupling after it is disassembled.
2. Connect the rigging to the motor, unbolt the motor from its base, and hoist it off the chiller.

Separate the External Gear from the Chiller

1. Drain the oil from the external gear box (Fig. 4, Item 10) before removing the flanges from the gear. A drain is located at the base of the external gear oil cooler (Fig. 4, Item 13). Unbolt the flanges from the supply line on the back of the gear (hidden in Fig. 4) and on the return line to the gear (Fig. 4, Item 14).
2. Connect the rigging to the external gear, unbolt the gear from its base, and hoist it off the chiller.

Separate the Condenser from the Chiller

1. Unbolt the condenser discharge pipe flange (Fig. 4, Item 5), if not already unbolted.
2. Unbolt flange at the shut-off valve (Fig. 4, Item 17).
3. Cut any copper pipes between the condenser and the rest of the chiller.
4. Unbolt hot gas bypass flange (Fig. 4, Item 19).
5. Connect the rigging to all corners of the condenser.
6. Unbolt the 4 condenser feet (Fig. 4, Item 18), 4 bolts on each foot.

Separate Cooler From Economizer/Storage Vessel — The compressor, gear, and motor must be removed from the chiller before separating the economizer/storage vessel from the cooler.

1. Remove condenser.
2. Cut any copper lines connecting the cooler to the economizer/storage vessel.

3. Unbolt the liquid refrigerant line at the flange (Fig. 4, Item 15).
4. Connect the rigging to all four corners of the cooler before lifting the unit.
5. Unbolt the connections (at both ends of the chiller) to the economizer/storage vessel (Fig. 4, Item 20).

Assemble the Chiller — The reassembly of the drive components, external gear, compressor, and motor requires a complete realignment and must be done by an experienced technician. Refer to the Start-Up, Operation, and Maintenance Instructions to reassemble the high and low speed couplings. Be sure to use the hardware saved with the disassembled couplings.

IMPORTANT: Do not substitute hardware when reassembling the couplings. Use only the hardware supplied by the coupling manufacturer.

Replace the coupling guards and realign the drive train before operating the chiller. Refer to the Start-Up, Operation, and Maintenance Instructions for this procedure.

1. Follow the disassembly instructions (in reverse order) and bolt all flanges back together using a gasket sealant. The torque required for the flange at the motor cooling drain line (hidden in Fig. 4) is 71 ft-lb (96 N-m). Additional torque requirements are listed below.

ITEMS IN FIG. 4	TORQUE	
	ft-lb	N-m
1	580	786
3 or 17	170	230
21	840*	1139*
19	380	515
16	250	340
20	280	380
4	170	230
5	380	515
Flange (motor cooling drain line)	71	96

LEGEND

N-m — Newton Meters

*This torque is used to rig the entire chiller. Once the chiller is in place, if no further rigging is anticipated, the bolt torque can be reduced to 280 ft-lb (380 N-m).

2. All gasketed or O-ring joints that have been disassembled must be reassembled using new gaskets and O-rings. These new gaskets and O-rings (along with gasket sealant, O-ring lubricant, and copper line couplings) are available through your Carrier representative.
3. Braze all copper lines back together using a suitable brazing material for copper. Carrier recommends an AWS (American Welding Society) Classification BCuP-2.

⚠ CAUTION

Do not tilt the compressor; oil is contained in the oil sump.

Additional Notes

1. Use silicon grease on the new O-rings when refitting.
2. Use gasket sealant on the new gaskets when refitting.
3. The cooler, economizer/storage vessel, and condenser vessels may be rigged vertically, as separate components. Rigging should be fixed to all four corners of the tube sheet.
4. New gaskets, grease for O-rings, and gasket sealant for a complete take-apart operation are available in a kit. Contact your Carrier representative.

COMPR END

DRIVE END

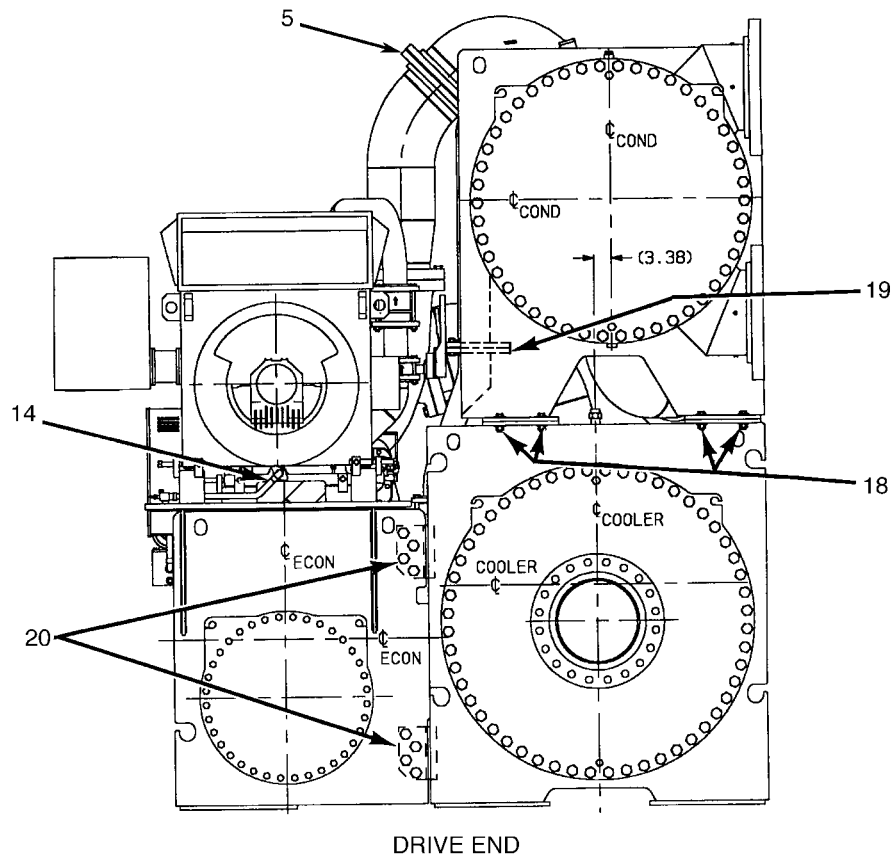
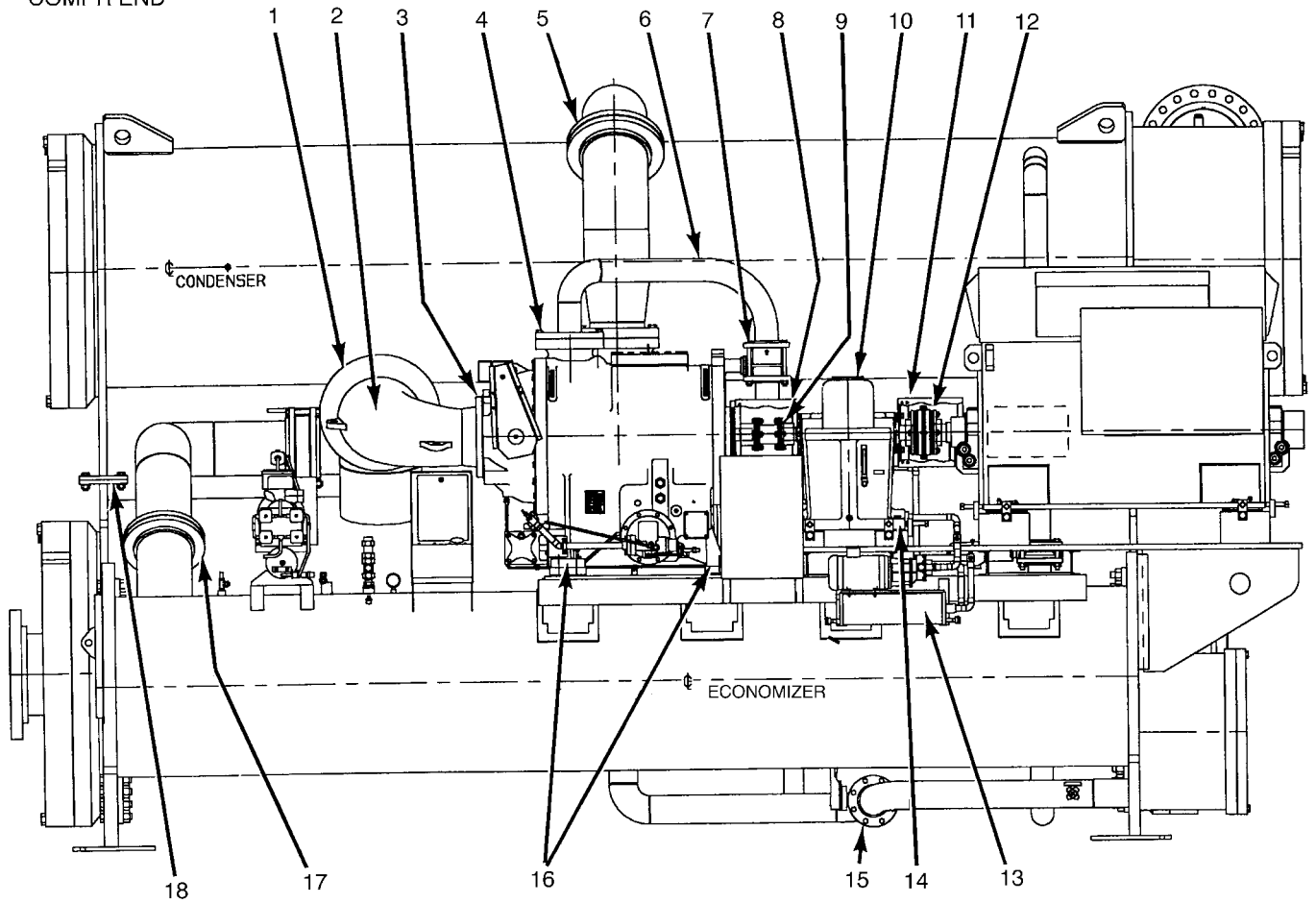
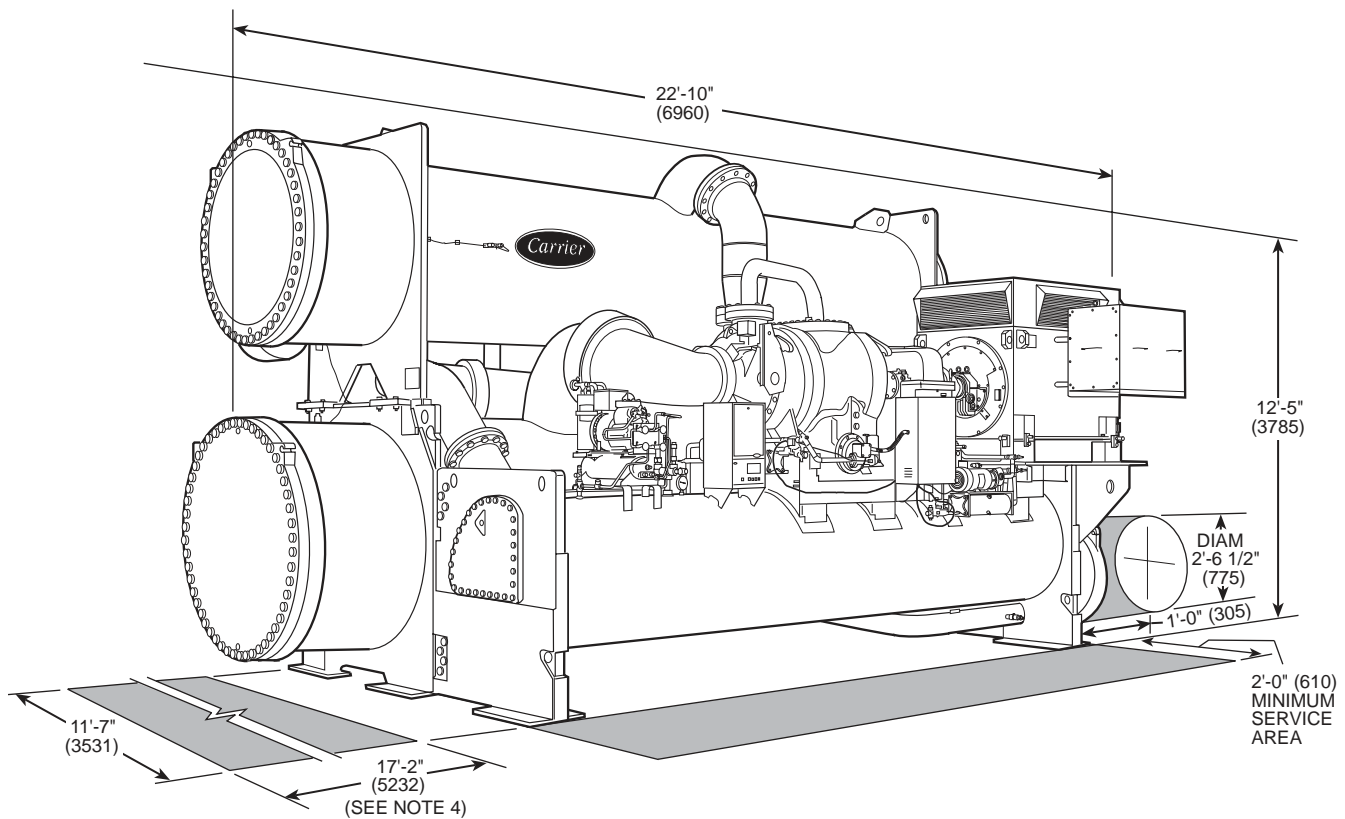

Fig. 4 — Typical View of 17EX



Nozzle Sizes

HEAT EXCHANGER	NOZZLE TYPE	NOZZLE SIZES (in.)					
		Cooler Passes			Condenser Passes		
		1	2	3	1	2	3
45-48	Marine	20	14	12	20	14	12
	NIH	18	14	10	18	12	10
55-57	Marine	—	—	—	—	16	—
	NIH	—	—	—	20	16	—

LEGEND

NIH — Nozzle-In-Head

NOTES:

1. Certified drawings available upon request.
2. The chiller height shown is based on a condenser size 55, 56, or 57. For chillers with condenser sizes 45, 46, or 47, subtract 3 in. (76 mm) from this height.
3. Service access should be provided per American Society of Heating, Refrigeration, and Air Conditioning Engineers (ASHRAE) 15, latest edition, National Electrical Code (NEC), and local safety codes.
4. Distance required for tube removal may be at either end.
5. Overall width of units will vary greatly depending on the application. See the appropriate certified drawings.
6. The table at the right provides additional information on nozzle sizes. Victaulic-type grooves are standard for these nozzles. Optional 150 psig (1034 kPa) and 300 psig (2068 kPa) flanges are available.

NOMINAL PIPE SIZE (in.)	SCHEDULE*	WALL THICKNESS	
		in.	mm
10	40	.365	9.27
12	Std	.375	9.53
14	30	.375	9.53
16	30	.375	9.53
18	Std	.375	9.53
20	20	.375	9.53

*In conformance with ASA B36.10 (American Standards Association).

Fig. 5 — Typical Dimensions

Table 1 — 17EX Heat Exchanger, Economizer/Storage Vessel, Piping, and Pumpout Unit Weights*

COOLER SIZE†	COOLER TOTAL WEIGHT				COOLER CHARGE						ECONOMIZER/STORAGE VESSEL		ECONOMIZER REFRIGERANT		MISC. PIPING		PUMP-OUT UNIT	
	Dry**		Operating††		Refrigerant		Water				lb	kg	lb	kg	lb	kg	lb	kg
	lb	kg	lb	kg	lb	kg	lb	gal	kg	L								
45	25,032	11 355	30,098	13 652	2,060	934	3,006	361	1 364	1 366	7,900	3 583	840	318	1,149	521	210	95
46	25,529	11 580	30,881	14 008	2,160	980	3,192	383	1 448	1 450								
47	26,025	11 805	31,663	14 362	2,260	1 025	3,378	405	1 532	1 533								
48	28,153	12 770	34,866	15 815	2,540	1 152	4,173	500	1 893	1 893								

CONDENSER SIZE†	CONDENSER TOTAL WEIGHT				CONDENSER CHARGE			
	Dry**		Operating††		Refrigerant		Water	
	lb	kg	lb	kg	lb	kg	lb	kg
45	16,676	7 564	20,596	9 342	1,200	544	2,720	1 234
46	17,172	7 789	21,280	9 653	1,200	544	2,908	1 319
47	17,669	8 015	21,965	9 963	1,200	544	3,096	1 404
55	20,725	9 401	25,598	11 611	1,420	644	3,453	1 566
56	21,663	9 826	26,891	12 198	1,420	644	3,808	1 727
57	22,446	10 182	27,971	12 688	1,420	644	4,105	1 862

*If a chiller configuration other than 2-pass, 150 psig (1034 kPa), NIH waterbox configuration is used, refer to Tables 3 and 4 to obtain the additional dry and water water weights that must be added to the values shown in this table.

†Cooler and condenser weights shown are based on 2-pass, nozzle-in-head (NIH) waterboxes with 150 psig (1034 kPa) covers. Includes components attached to cooler, but does not include suction/discharge, elbow, or other interconnecting piping.

**Dry weight includes all components attached to economizer: covers, float valves, brackets, control center (31 lb [14 kg]), and power panel (20 lb [9 kg]). Dry weight does not include compressor weight, motor weight, or pumpout condensing unit weight. The pumpout condensing unit weight is 210 lb (95 kg). For compressor and motor weights, refer to Tables 6, 8A, and 8B.

††Operating weight includes dry weight, refrigerant weight, and water weight.

Table 2 — Total Refrigerant (HCFC-134a) Charge*

COOLER SIZE	CONDENSER SIZE	TOTAL CHILLER CHARGE	
		lb	kg
45	45	4100	1860
	46		
	47		
	55		
	56		
46	45	4200	1905
	46		
	47		
	55		
	56		
47	45	4300	1950
	46		
	47		
	55		
	56		
48	45	4580	2077
	46		
	47		
	55		
	56		

*Total chiller refrigerant charge includes the cooler, condenser, and economizer charges.

NOTE: Regulations mandate that chiller shipping charge is limited to 7500 lb (3402 kg).

Table 3 — Additional Cooler Weights*

COOLER SIZES	WATERBOX TYPE	NUMBER OF PASSES	DESIGN MAXIMUM WATER PRESSURE		ADDITIONAL DRY WEIGHT		ADDITIONAL WATER WEIGHT	
			psig	kPa	lb	kg	lb	kg
45, 46, 47, 48	NIH	1, 3	150	1034	515	234	—	—
	NIH	1, 3	300	2068	2941	1334	—	—
	NIH	2	300	2068	2085	946	—	—
	Marine	1, 3	150	1034	2100	953	5102	2314
	Marine	2	150	1034	792	359	2551	1157
	Marine	1, 3	300	2068	3844	1744	5102	2314
	Marine	2	300	2068	2536	1150	2551	1157

LEGEND

NIH — Nozzle-In-Head

*When using a chiller configuration other than 2-pass, NIH waterboxes with 150 psig (1038 kPa) covers, add the weights listed in this table to the appropriate weights in Table 1 to obtain the correct cooler weight.

Table 4 — Additional Condenser Weights*

COMPONENT	HEAT EXCHANGER SIZE	WATERBOX TYPE	NUMBER OF PASSES	DESIGN MAXIMUM WATER PRESSURE		ADDITIONAL DRY WEIGHT		ADDITIONAL WATER WEIGHT			
				psig	kPa	lb	kg	lb	gal	kg	L
CONDENSER	45-47	NIH	1, 3	150	1034	344	156	—	—	—	—
		NIH	1, 3	300	2068	1652	749	—	—	—	—
		NIH	2	300	2068	1132	513	—	—	—	—
		Marine	1, 3	150	1034	1692	767	3400	408	1542	1542
		Marine	2	150	1034	674	306	1700	204	771	771
		Marine	1, 3	300	2068	2651	1202	3400	408	1542	1542
		Marine	2	300	2068	1630	739	1700	204	771	771
	55-57	NIH	1	150	1034	†	†	—	—	—	—
		NIH	1	300	2068	1588	720	—	—	—	—
		NIH	2	300	2068	1591	721	—	—	—	—
		Marine	2	150	1034	25	11	1734	208	787	787
		Marine	2	300	2068	1225	555	1734	208	787	787

LEGEND

NIH — Nozzle-In-Head

*When using a chiller configuration other than 2-pass, NIH waterboxes with 150 psig (1034 kPa) covers, add the weights listed in this table to the appropriate weights in Table 1 to obtain the correct condenser weight.

†Subtract 228 lb (103 kg) from the weight shown in Table 1.

Table 5 — Auxiliary Connection Sizes

SIZE AND STYLE	USAGE
3/8 in. Male Flare	Pumpout Condenser Refrigerant Vapor Connection (Rupture Disc)
1/2 in. FPT	Pumpout Water Inlet Connection
	Pumpout Water Outlet Connection
1/2 in. NPT Conduit	Power Panel Oil Pump Power Connection (For Compressor and Gear Oil Pumps)
1 in. NPT	Waterbox Vent Connection
	Waterbox Drain Connection
3/4 in FPT	Compressor Oil Cooler Connection
	Gear Oil Cooler Connection
1 1/4 in. FPT	Cooler Relief Valve Connection
	Economizer/Storage Vessel Connection

Table 6 — Compressor/Suction Elbow Weights (All Compressor Sizes)

ENGLISH (lb)	SI (kg)
18,947*	8 384†

*Based on 6900 v, FK motor.

†Based on 6300 v, FK motor.

Table 7 — Drive Component Weights*

BASE		GEAR		COUPLING				GUARD	
lb	kg	lb	kg	High		Low		lb	kg
				lb	kg	lb	kg		
2200	998	1500	680	32	15	75	34	50	23

*See Tables 8A and 8B for motor weights.

Table 8A — Total Motor Weight, English (lb)

ENCLOSURE TYPE	HERTZ	VOLTAGE	SIZE (HP)				
			FA, FF (1250)	FB, FG (1500)	FH (1600)	FC, FJ (1750)	FD, FK (2000)
Open-Drip Proof (ODP)	60 Hz	2400	4836	5721	5900	5900	7160
		3300	4824	5832	5832	5832	7127
		4160	4836	5721	5900	5900	7160
		6900	5596	6577	8776	8776	8990
	50 Hz	3000	5518	5878	7148	7148	9048
		3300	5518	5878	7148	7148	9073
6300	5596	6577	8875	8875	8976		
Weather Protected Type II (WPII)	60 Hz	2400	5146	6151	6330	6330	7600
		3300	5134	6262	6262	6262	7567
		4160	5146	6151	6330	6330	7600
		6900	5906	7007	9206	9206	9430
	50Hz	3000	5828	6308	7578	7578	9488
		3300	5828	6308	7578	7578	9513
6300	5906	7007	9305	9305	9416		
Totally Enclosed Water-To-Air Cooled (TEWAC)	60 Hz	2400	5707	6746	6925	6925	8290
		3300	5694	6857	6857	6857	8257
		4160	5707	6746	6925	6925	8290
		6900	6466	7602	9801	9801	10,120
	50 Hz	3000	6388	6903	8173	8173	10,178
		3300	6388	6903	8173	8173	10,203
6300	6466	7602	9900	9900	10,106		

Table 8B — Total Motor Weight, SI (kg)

ENCLOSURE TYPE	FREQ	VOLTAGE	SIZE (kW)				
			FA, FF (932)	FB, FG (1119)	FH (1194)	FC, FJ (1305)	FD, FK (1492)
Open-Drip Proof (ODP)	60 Hz	2400	2194	2595	2676	2676	3248
		3300	2188	2645	2645	2645	3233
		4160	2194	2595	2676	2676	3248
		6900	2538	2983	3981	3981	4033
	50 Hz	3000	2503	2666	3242	3242	4104
		3300	2503	2666	3242	3242	4116
6300	2538	2983	4026	4026	4072		
Weather Protected Type II (WPII)	60 Hz	2400	2334	2790	2871	2871	3447
		3300	2329	2840	2840	2840	3432
		4160	2334	2790	2871	2871	3447
		6900	2679	3178	4175	4126	4277
	50 Hz	3000	2644	2861	3437	3437	4304
		3300	2644	2861	3437	3437	4315
6300	2679	3178	4221	4221	4271		
Totally Enclosed Water-To-Air Cooled (TEWAC)	60 Hz	2400	2587	3060	3141	3141	3760
		3300	2583	3110	3110	3110	3745
		4160	2587	3060	3141	3141	3760
		6900	2933	3448	4446	4446	4590
	50 Hz	3000	2898	3131	3707	3707	4617
		3300	2898	3131	3707	3707	4628
6300	2933	3448	4491	4490	4584		

Table 9 — Marine Waterbox Cover Weights*

HEAT EXCHANGER SIZE	DESIGN MAXIMUM WATER PRESSURE		COOLER		CONDENSER	
	psi	kPa	lb	kg	lb	kg
45-48	150	1034	2236	1015	1275	579
	300	2068	3060	1389	1660	754
55-57	150	1034	—	—	1643	746
	300	2068	—	—	2243	1018

*Heat exchangers with marine waterboxes have heavier dry and operating weights than heat exchangers with nozzle-in-head waterboxes.

Table 10 — NIH Waterbox Cover Weights*

HEAT EXCHANGER SIZE	PASSES	DESIGN MAXIMUM WATER PRESSURE		COOLER		CONDENSER	
		psi	kPa	lb	kg	lb	kg
45-48	1	150	1034	2997	1361	1735	788
		300	2068	4225	1918	2510	1140
	2†	150	1034	2984	1355	1885	856
		300	2068	4188	1901	2590	1176
	3	150	1034	3035	1378	1777	807
		300	2068	4244	1927	2539	1153
55-57	1	150	1034	—	—	2032	923
		300	2068	—	—	2940	1335
	2†	150	1034	—	—	2649	1203
		300	2068	—	—	3640	1653
	3	150	1034	—	—	—	—
		300	2068	—	—	—	—

LEGEND

NIH — Nozzle-in-Head

*The 150 psig (1034 kPa) waterbox cover weights are included in the dry weight shown in Table 1.

†Two different waterbox covers are present on 2-pass chillers. The weight shown in this table represents the weight of the waterbox cover that contains the nozzles. A blank waterbox cover is also present on 2-pass units. The weight of the blank waterbox cover is identical to the weight of the same size marine waterbox cover. Refer to Table 9.

Install Chiller Supports

INSTALL STANDARD ISOLATION — Figures 6 and 7 show the position of support plates and shear flex pads, which together form the standard chiller support system. The plates must be level within 1/16-in. with respect to each other. Add field-supplied leveling pads between the plates and the floor, if necessary.

⚠ CAUTION

The chiller will vibrate if it is not leveled properly.

INSTALL OPTIONAL ISOLATION (if required) — Uneven floors or other considerations may dictate the use of soleplates and leveling pads. Refer to Fig. 6 and 7.

Level chiller by using jacking screws in isolation soleplates. Use a level at least 24 in. (600 mm) long.

For adequate and long lasting chiller support, proper grout selection and placement is essential. Carrier recommends that only pre-mixed, epoxy-type, non-shrinking grout be used for chiller installation. Follow manufacturer’s instructions in applying grout.

1. Check chiller location prints for required grout thickness.
2. Carefully wax jacking screws for easy removal from grout.
3. Grout must extend above the base of the soleplate and there must be no voids in grout beneath the plates.

4. Allow grout to set and harden, per manufacturer’s instructions, before starting chiller.
5. Remove jacking screws from leveling pads after grout has hardened.

INSTALL SPRING ISOLATION — Field-supplied spring isolators may be placed directly under chiller support plates or be located under chiller soleplates. Consult job data for specific arrangement. Low profile spring isolation assemblies are recommended so that the chiller is kept at a convenient working height inside the tube sheet.

Obtain specific details on spring mounting and chiller weight distribution from job data. Also, check job data for methods of supporting and isolating pipes that are attached to the spring-isolated chillers.

Connect Piping

INSTALL WATER PIPING TO HEAT EXCHANGERS — Install piping using job data, piping drawings, and procedure outlined below. A typical piping installation is shown in Fig. 8.

⚠ CAUTION

Factory-supplied insulation is not flammable but can be damaged by welding sparks and open flame. Protect insulation with a wet canvas cover.

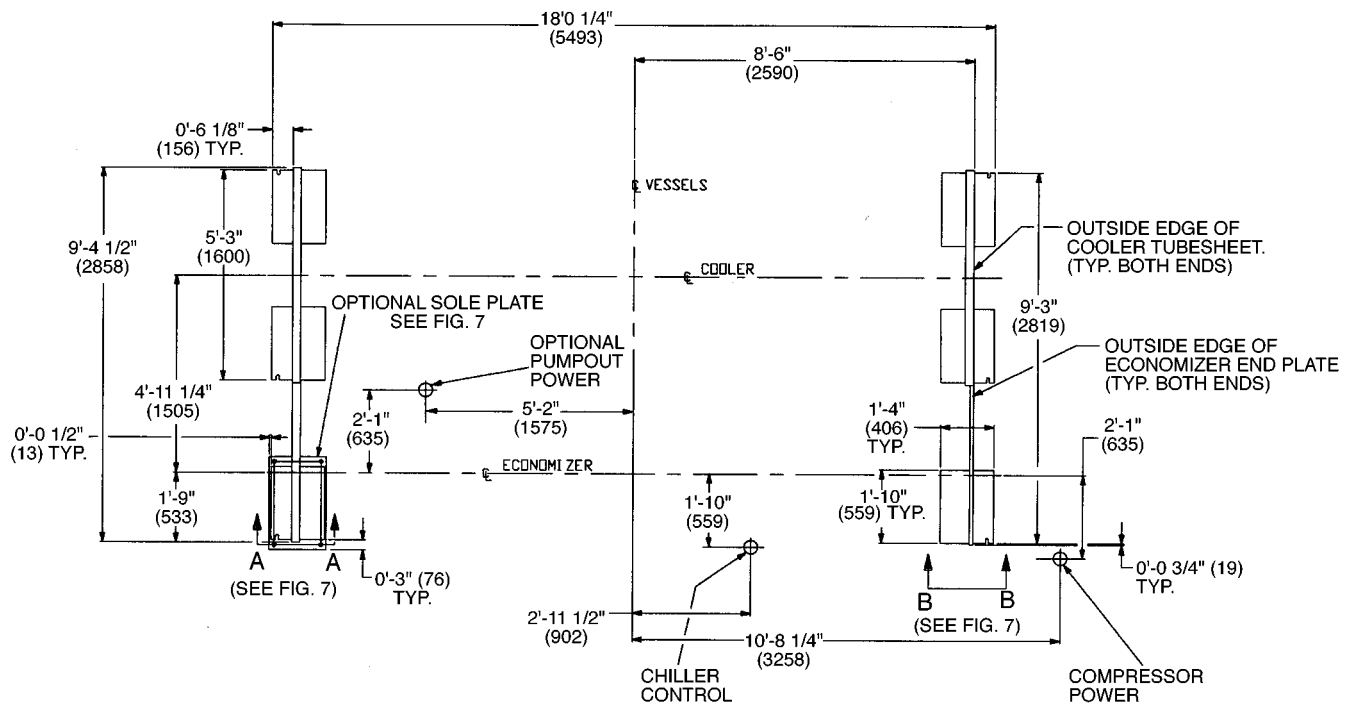

NOTES:

1. Dimensions in () are in mm.
2. One inch = 25.4 mm.
3. All dimensions are approximately ± 1/2 inch.
4. Use grout and package components as shown in Fig. 7 to establish the level base line.
5. If chiller is set on a concrete pad, the pad should extend at least 2'-6" (762 mm) beyond the width of the chiller on the economizer side.
6. Power/control locations are approximate.

Fig. 6 — Chiller Contact Surfaces

CAUTION

Remove chilled and condenser water sensors before welding connecting pipes to water nozzles. Be sure to label each sensor. Refer to Fig. 2 and 3. Replace sensors after welding is complete.

1. If the chiller is a nozzle-in-head (NIH) arrangement, offset the pipe flanges to permit removal of waterbox cover for maintenance and to provide clearance for pipe cleaning. See Tables 9 and 10 for waterbox cover weights. No flanges are necessary with marine waterboxes; however, water piping should not cross in front of the waterbox or access will be blocked.
2. Provide openings in water piping for required pressure gages and thermometers. Openings should be at least 6 to 10 pipe diameters from the waterbox nozzle. For thorough mixing and temperature stabilization, wells in the leaving water pipe should extend inside pipe at least 2 in. (50 mm).
3. Install air vents at all high points in piping to remove air and prevent water hammer.
4. Install pipe hangers where needed. Make sure no weight or stress is placed on waterbox nozzles or flanges.
5. Water flow direction must be as specified in Fig. 9.

NOTE: Entering water is always the lower of the 2 nozzles. Leaving water is always the upper nozzle for cooler or condenser.

6. Water flow switches must be of vapor-tight construction and must be installed on top of pipe in a horizontal run and at least 5 pipe diameters from any bend. Differential pressure type flow switches may be connected at the nozzle of the waterbox.
7. Install waterbox vent and drain piping in accordance with individual job data. All connections are 3/4-in. FPT.
8. Install waterbox drain plugs in the unused waterbox drains and vent openings.
9. Install water piping to the optional pump out system condenser connections as shown in Fig. 10. Both connections are 1/2-in. NPT (female). A shutoff valve should be installed in the water line. Provide a way to blow water from the condenser tubes at winter shutdown to prevent freeze-up damage. Refer to the job data for water piping particulars.

INSTALL WATER TO OIL COOLERS ON COMPRESSOR AND EXTERNAL GEAR — There are 2 oil cooler heat exchangers on this chiller, one each for the compressor and the external gear.

Water must be piped to the compressor oil cooler heat exchanger (located under the suction pipe to the compressor) and to the gear oil cooler heat exchanger (Fig. 2, Item 17). The water supply may be either city water or chilled water. Pipe city water to an open sight drain. Chilled water enters via the cooler entering water intake (Fig. 11).

SOLEPLATE ISOLATION

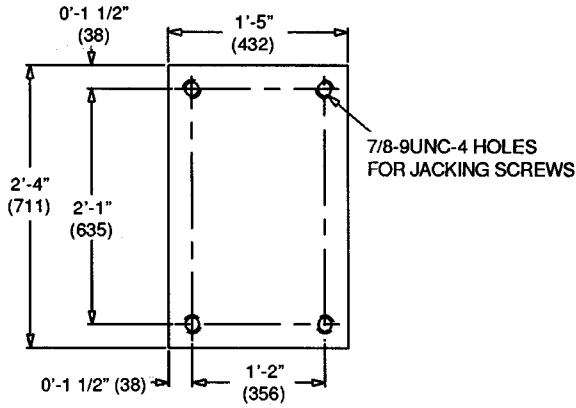

TYPICAL ISOLATION

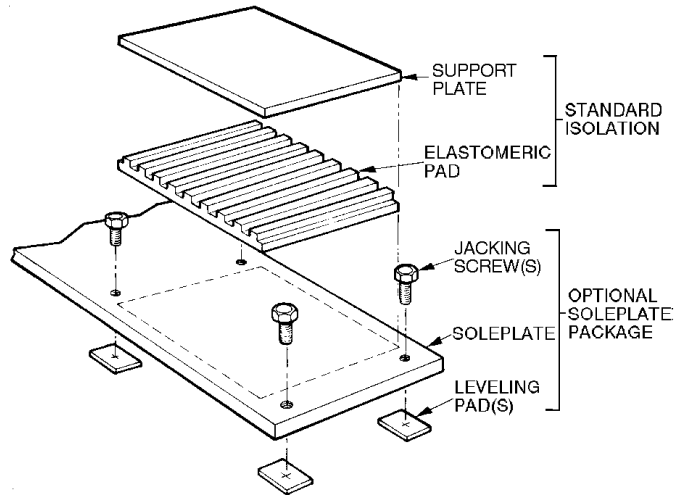

ACCESSORY ISOLATION

SOLEPLATE DETAIL SECTION A-A

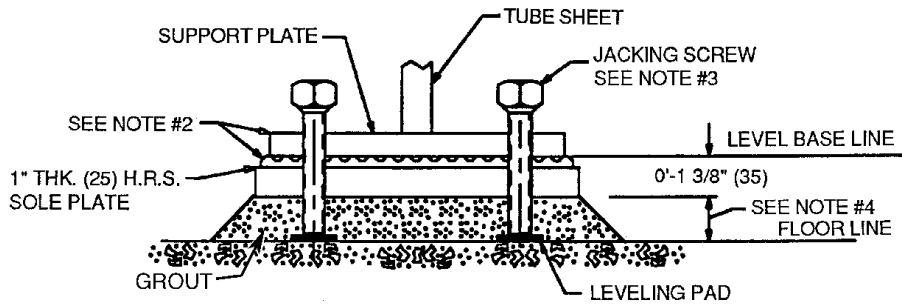

NOTES:

1. Dimensions in () are in millimeters.
2. Accessory soleplate package includes 4 soleplates, 16 jacking screws and leveling pads. Requires isolation package.
3. Jacking screws to be removed after grout has set.
4. Thickness of grout will vary, depending on the amount necessary to level chiller. Use only pre-mixed non-shrinking grout, Five Star® epoxy grout or Ceilcote 648.

STANDARD ISOLATION

VIEW B-B

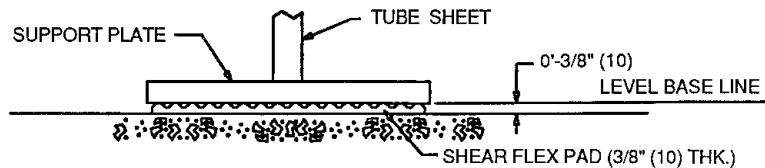

ISOLATION WITH ISOLATION PACKAGE ONLY (STANDARD)

NOTE: Isolation package includes 4 shear flex pads.

Fig. 7 — Chiller Vibration Isolation

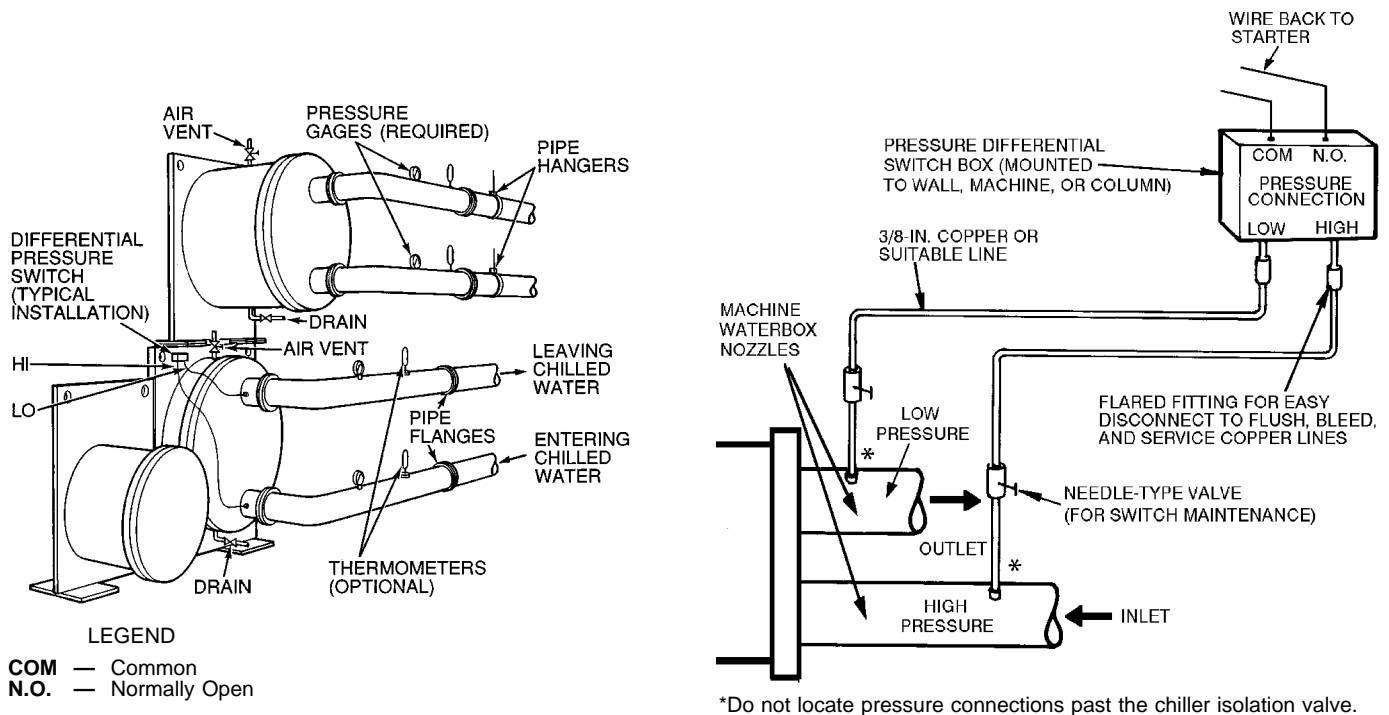

Fig. 8 — Typical Nozzle Piping

*Do not locate pressure connections past the chiller isolation valve.

CAUTION

City water must be clean and noncorrosive. Water side erosion or corrosion of the oil cooler coils may lead to extensive chiller damage not covered by the standard warranty.

If water from the chilled water circuit is used for oil cooling, it must enter the oil coolers from the entering water line of the chiller cooler. Water leaving the oil coolers must connect to the leaving water line of the chiller cooler at a point downstream from the chilled water sensor, so that the oil cooler leaving water temperatures do not affect the sensor readings.

Locate the oil cooler leaving water connections at some distance from any water temperature indicators. On single-pass chillers, water leaving the oil coolers should be connected into the suction side of the chilled water pump so that adequate pressure drop is assured for oil cooling.

The nominal conditions for compressor oil cooler and external gear oil cooler water flow are:

CONDITION	COMPRESSOR OIL COOLER	EXTERNAL GEAR OIL COOLER
Minimum Flow Rate	13 gpm (0.82 L/s)	8 gpm (0.51 L/s)
Entering Temperature	85 F (29 C)	85 F (29 C)
Pressure Drop at Oil Cooler	28.6 psid (197 kPad)	13.8 psid (95.2 kPad)
Maximum Differential Pressure Across Closed Solenoid Valve	150 psid (1034 kPad)	150 psid (1034 kPad)

The oil cooler connections are 3/4-in. FPT.

INSTALL VENT PIPING TO RELIEF DEVICES — The 17EX chiller is factory equipped with relief devices on the cooler and utility vessels. Refer to Fig. 2 and Table 11 for size and location of relief devices, as well as information that will help determine pipe size. Vent relief devices to the outdoors in accordance with ASHRAE 15 (latest edition) Safety Code for Mechanical Refrigeration and all other applicable codes. To ensure relief valve serviceability, and as required in ASHRAE 15, latest edition, 3-way dual shutoff valves and redundant relief valves are installed on the economizer/storage vessel, refer to Fig. 12.

NOTE: The 3-way dual shutoff valve should be either front seated or back seated. Running the refrigeration system with the valve stem in the center position can reduce total relief capacity and cause valve chattering.

DANGER

Refrigerant discharged into confined spaces can displace oxygen and cause asphyxiation.

1. If relief device piping is manifolded, the cross-sectional area of the relief pipe must at least equal the sum of the areas required for individual relief pipes.
2. Provide a pipe plug near outlet side of each relief device for leak testing. Provide pipe fittings that allow vent piping to be disconnected periodically for inspection of valve mechanism.
3. Piping to relief devices must not apply stress to the device. Adequately support piping. A length of flexible tubing or piping near the device is essential on spring-isolated chillers.
4. Cover the outdoor vent with a rain cap and place a condensation drain at the low point in the vent piping to prevent water build-up on the atmospheric side of the relief device.

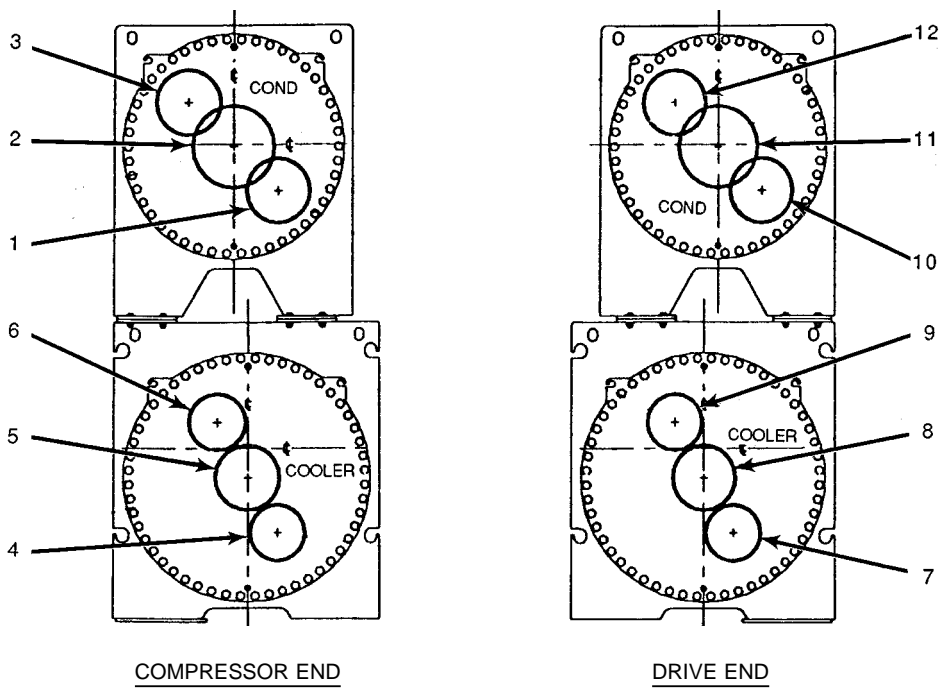

NOZZLE-IN-HEAD WATERBOXES

COOLER WATERBOX			
Pass	In	Out	Arr. Code
1	8	5	A
	5	8	B
2	7	9	C
	4	6	D
3	7	6	E
	4	9	F

CONDENSER WATERBOX			
Pass	In	Out	Arr. Code
1	11	2	P
	2	11	Q
2	10	12	R
	1	3	S
3	10	3	T
	1	12	U

- NOTES:
1. Frame 5 condenser available in 1 and 2 pass only.
 2. The vents for these waterboxes, located in the covers are 1 in. FPT at the top of each box, and the drains are 1 in. FPT, at the bottom.
 3. Victaulic connections are standard.
 4. Flanged waterbox connections are optional.

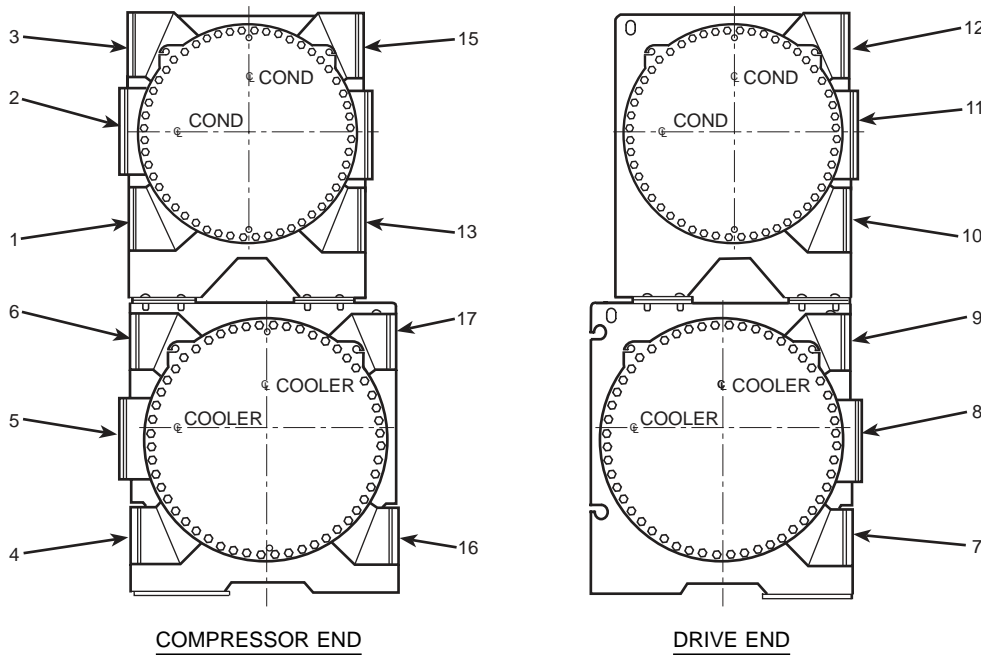

MARINE WATERBOXES

COOLER WATERBOX			
Pass	In	Out	Arr. Code
1	8	5	A
	5	8	B
2	7	9	C
	4	6	D
3	16	17	G
	7	6	E
	4	9	F

CONDENSER WATERBOX			
Pass	In	Out	Arr. Code
1	11	2	P
	2	11	Q
2	10	12	R
	1	3	S
3	13	15	Y
	10	3	T
	1	12	U

- NOTES:
1. Frame 5 condenser available in 2 passes only.
 2. The vents for these waterboxes are 1 in. FPT at the top of each box, and the drains are 1 in. FPT, at the bottom.
 3. Victaulic connections are standard.
 4. Flanged waterbox connections are optional.

Fig. 9 — Nozzle Arrangements

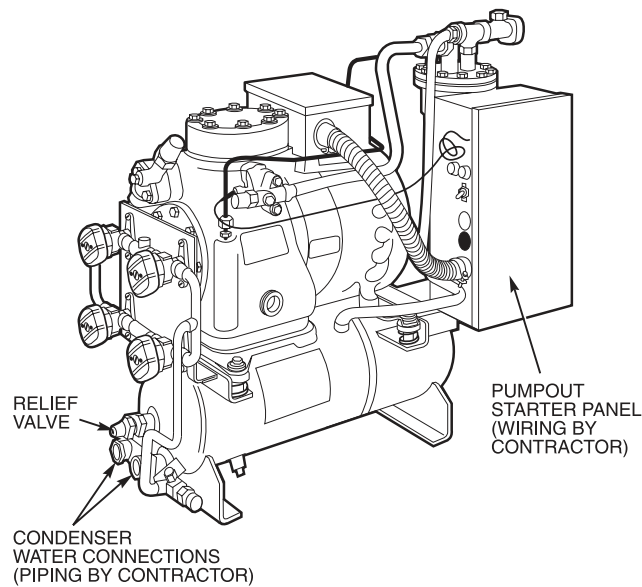

Fig. 10 — Pumpout Unit

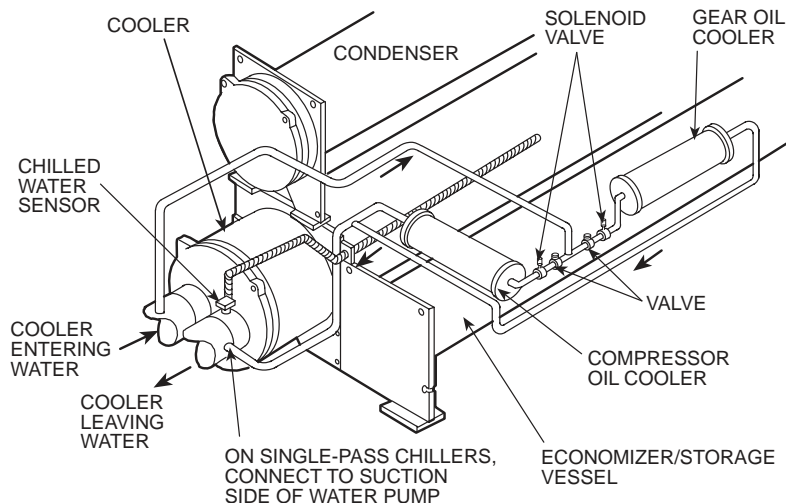

Fig. 11 — Water Piping, Oil Coolers to Chilled Water Circuit (Typical)

Table 11 — Relief Valve Locations and Data

RELIEF VALVE LOCATION	HEAT EXCHANGER SIZE		REQUIRED C FACTOR		NOMINAL OUTLET PIPE SIZE (in.)	NUMBER OF VALVES	RATED RELIEF PRESSURE	
	Cooler	Condenser	lb air/min.	kg air/sec.			psig	kPa
Cooler	45-47	45-47	216.3	1.64	1¼ FPT	3	225	1551
	48	55-57	228.5	1.73	1¼ NPT	3	225	1551
Economizer/Storage Vessel	ALL	ALL	84.3	0.64	1¼ FPT	2*	225	1551
Pumpout Unit Condenser	ALL	ALL	1.5	0.01	⅜ in. Male Flare MPT	1	385	2655

*To ensure relief valve serviceability, and as required in ASHRAE 15, latest edition, three-way valves and redundant relief valves are installed on the storage vessel. Only one of the "No. of Valves" listed is in service at any time.

NOTES:

1. The cooler relief C-factor is for both cooler and condenser vented through the cooler in accordance with ASHRAE (American Society of Heating, Refrigeration, and Air Conditioning Engineers) 15, latest edition.

2. Relief valve discharge pipe sizing is to be calculated per latest version of ASHRAE 15, using the tabulated C-factors and nominal pipe size listed above. Cooler and economizer/storage vessel rated relief valve pressure is 225 psig (1551 kPa).

3. The pumpout unit condenser contains less than 110 lb (50 kg) of HFC-134a, which is a Group A1 refrigerant. The ASHRAE 15 standard exempts small-volume vessels from the requirement to vent outside. However, Carrier recommends that the pumpout condenser be connected to the rest of the vent system.

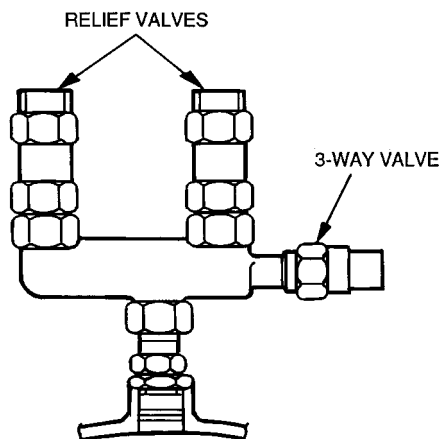

Fig. 12 — Typical Economizer/Storage Vessel Relief Valve Tee

Make Electrical Connections — Field wiring must be installed in accordance with job wiring diagrams and all applicable electrical codes.

⚠ CAUTION

Do not run 120-v wiring into the control center. The control center should only be used for additional extra low-voltage wiring (50 v maximum).

Wiring diagrams in this publication (Fig. 13-19) are for reference only and are not intended for use during actual installation; follow job-specific wiring diagrams.

Specific electrical ratings for individual components are shown in Table 12.

⚠ WARNING

Do not attempt to start compressor oil pump — even for a rotation check — or apply test voltage of any kind while chiller is under dehydration vacuum. Motor insulation breakdown and serious damage may result.

CONNECT CONTROL INPUTS — Connect the control input wiring from the chilled and condenser water flow switches to the starter terminal strip. Wiring may also be specified for a spare safety switch, and a remote start/stop contact can be wired to the starter terminal strip, as shown in Fig. 15 and 16. Additional spare sensors and Carrier Comfort Network modules may be specified as well. These are wired to the chiller control center as indicated in Fig. 18 and 19.

CONNECT CONTROL OUTPUTS — Connect auxiliary equipment, chilled and condenser water pumps, and spare alarms as required and indicated on job wiring drawings.

Connect Starter — Assemble and install compressor terminal box in desired orientation, and cut necessary conduit openings in conduit support plates. Attach power leads to compressor terminals in accordance with job wiring drawings, observing the caution label in terminal box. Use only

Table 12 — Individual Component Ratings

POWER SOURCE	ITEM	AVERAGE kW	DESIGN CENTER VOLTAGE	SUPPLY V-PH-Hz	FLA	LRA
1	Seal Leakage Pump	0.23	115	115-1-50/60	4.78	21.7
	Motor Space Heater	0.50	115	115-1-50/60	4.35	4.35
	Control Module and Actuator	0.40	115	115-1-60 115-1-50	3.50	—
	Oil Sump Heater	1.00	115	115-1-60 115-1-50	8.70	—
1*	Hot Gas Bypass	0.20	115	115-1-50/60	2.00	4.75
2†	Compressor Oil Pump	0.66	220	200/240-3-60	4.34	24.5
			430	380/480-3-60	2.15	13.1
3†	Gear Oil Pump	0.7	563	507/619-3-60	2.14	25.0
			230	220/240-3-50	4.84	28.0
			393	346/440-3-50	2.59	12.2
			204	200/208-3-60	5.7	33.5
			220	208/230-3-60	4.2	30.6
			460	440/480-3-60	2.1	15.3
4*	Pumpout Compressor	3.41	575	518/632-3-60	1.7	12.3
			205	190/220-3-50	5.0	28.9
4*	Pumpout Compressor	3.41	410	380/440-3-50	2.5	14.5
			204	200/208-3-60	10.90	63.5
			230	220/240-3-60	9.50	57.5
			460	440/480-3-60	4.70	28.8
			575	550/600-3-60	3.80	23.0
400	380/415-3-50	4.70	28.8			

LEGEND

FLA — Full Load Amps

LRA — Locked Rotor Amps

*Available as an option on 17EX chillers.

†The compressor and gear oil pump contactors are wired together on the line side. Their amperage values must be added together when sizing conductors.

NOTE: The oil pump is powered through a field wiring terminal into the power panel. Power to the controls and oil heater via the power panel must be on circuits that can provide continuous service when the compressor starter is disconnected.

copper conductors. The motor must be grounded in accordance with NEC (National Electrical Code), applicable local codes, and job wiring diagrams.

IMPORTANT: Do not insulate terminals until wiring arrangement has been checked and approved by Carrier start-up personnel. Also, make sure correct phasing is followed for proper motor rotation.

Insulate Motor Terminals and Lead Wire Ends — Insulate compressor motor terminals, lead wire ends, and electrical wires to prevent moisture condensation and electrical arcing. For low-voltage units (up to 600 v), insulate the electrical terminals as follows:

1. Insulate each terminal by wrapping with one layer of insulation putty.
2. Overwrap putty with 4 layers of vinyl tape.

High-voltage units require special terminal preparation. The vinyl tape is not acceptable; a high voltage tape must be used. Installer is responsible for any damage caused by improper wiring between starter and compressor motor.

Connect Power Wires to Oil Pump Contactor — Connect compressor oil pump and external gear oil pump power wires to oil pump contactor mounted in chiller power panel. (See Fig. 13.) Use the electrical disconnect located in the chiller starter (if supplied) or a separate fused disconnect as shown on job wiring diagrams. Check that power supply voltage agrees with compressor and gear oil pump voltage. Follow correct phasing for proper motor rotation.

⚠ CAUTION

Do not wire into the top surface of the power panel. Knock-outs are provided on the underside of the panel.

Connect Power Wires to Oil Heater Contactor — Refer to Fig. 14 and wiring label on the chiller power panel. Connect control power wiring between the oil heater contactor terminals (Fig. 15) and terminals LL1 and LL2 on the field wiring strip in the compressor motor starter.

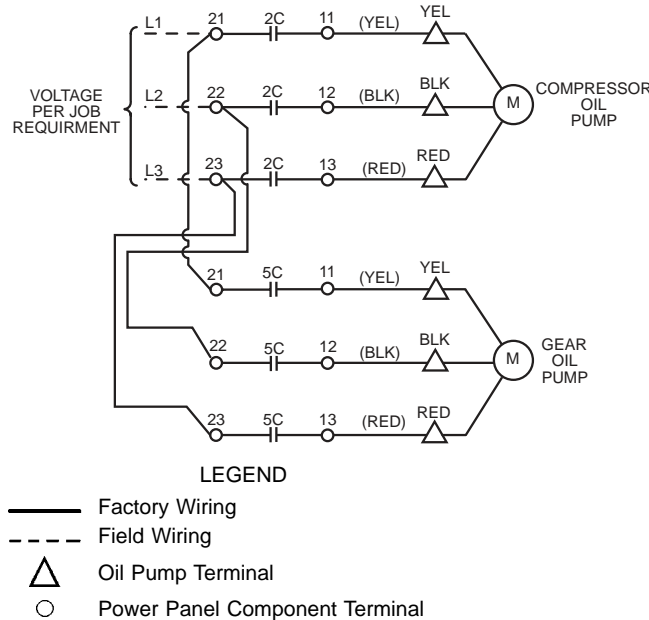
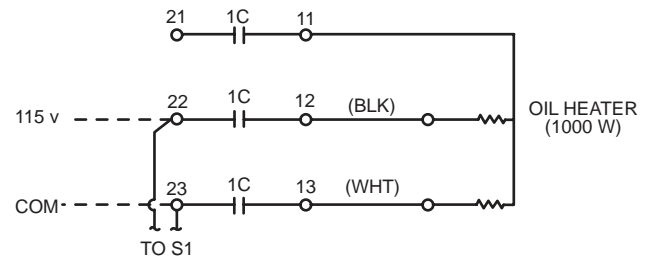

Fig. 13 — Oil Pump Wiring



LEGEND

- Field Wiring
- Power Panel Component Terminal

Fig. 14 — Oil Heater and Control Power Wiring

⚠ WARNING

Voltage to terminals LL1 and LL2 comes from a control transformer in a starter built to Carrier specifications. Do not connect an outside source of control power to the compressor motor starter (terminals LL1 and LL2). An outside power source will produce dangerous voltage at the line side of the starter, because supplying voltage at the transformer secondary terminals produces input level voltage at the transformer primary terminals.

Connect Communication and Control Wiring from Starter to Power Panel — Connect control wiring from main motor starter to the chiller power panel. All control wiring must use shielded cable. Also connect the communications cable. Make sure the control circuit is grounded in accordance with applicable electrical codes and instructions on chiller control wiring label.

CARRIER COMFORT NETWORK INTERFACE — The Carrier Comfort Network (CCN) communication bus wiring is supplied and installed by the electrical contractor (if required by jobsite prints). It consists of shielded, 3-conductor cable with drain wire.

The system elements are connected to the communication bus in a daisy chain arrangement. The positive pin of each system element communication connector must be wired to the positive pins of the system element on either side of it. The negative pins must be wired to the negative pins. The signal ground pins must be wired to the signal ground pins. See Fig. 18 and 19 for location of the CCN network connector (COMM1) on the processor module.

NOTE: Conductors and drain wire must be 20 AWG (American Wire Gage) minimum stranded, tinned copper. Individual conductors must be insulated with PVC, PVC/nylon, vinyl, Teflon™, or polyethylene. An aluminum/polyester 100% foil shield and an outer jacket of PVC, PVC/nylon, chrome vinyl, or Teflon with a minimum operating temperature range of -4 F to 140 F (-20 C to 60 C) is required. See table below for cables that meet the requirements.

MANUFACTURER	CABLE NO.
Alpha	2413 or 5463
American	A22503
Belden	8772
Columbia	02525

Copy continued on page 25.

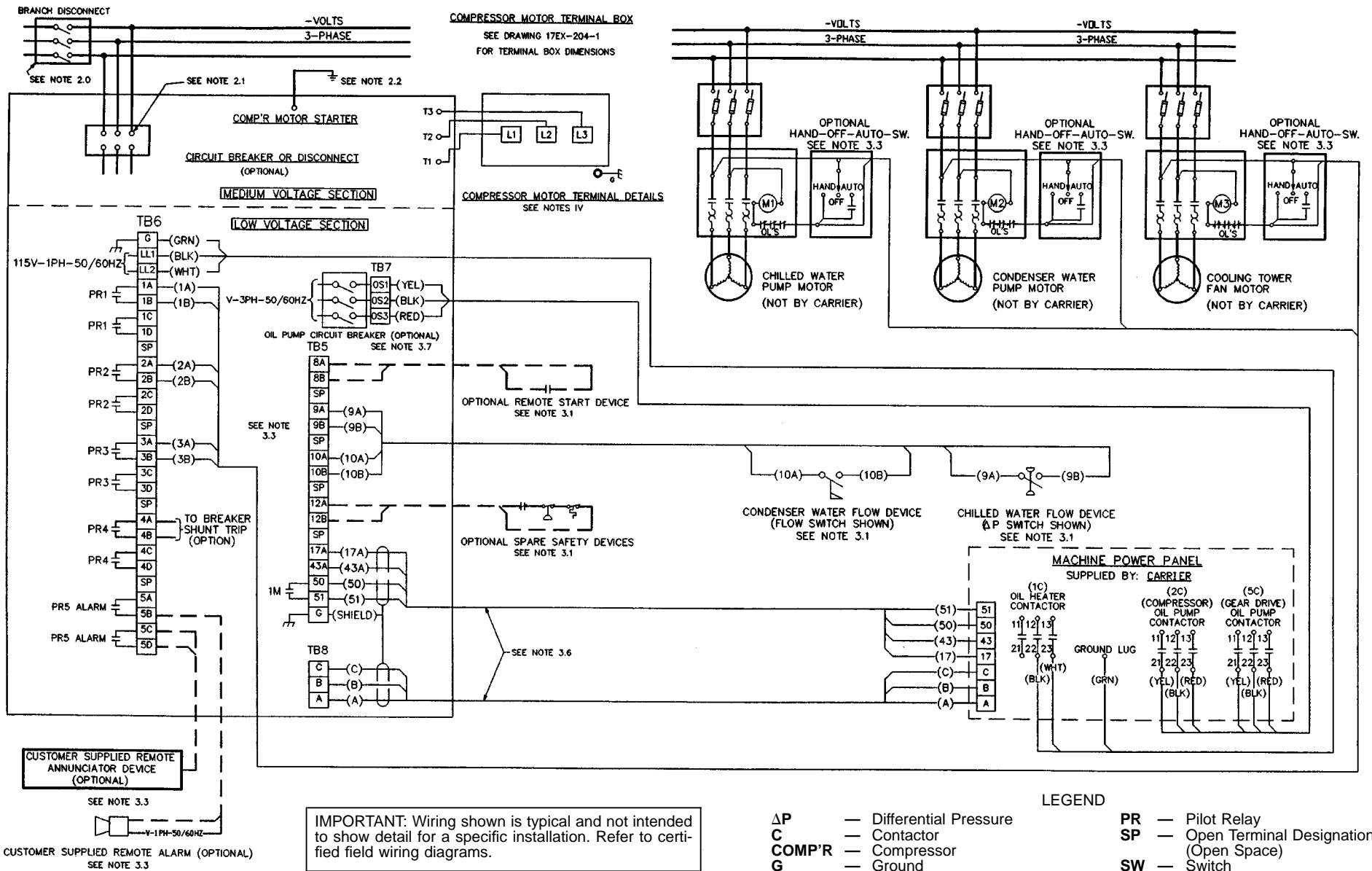

See Notes on page 21.

Fig. 15 — Typical Field Wiring (Medium Voltage Chiller Shown)

NOTES FOR FIGURE 15

I GENERAL

- 1.0 Starters shall be designed and manufactured in accordance with Carrier Engineering requirement Z-375.
- 1.1 All field-supplied conductors and devices, field-installation wiring, and termination of conductors and devices must be in compliance with all applicable codes and job specifications.
- 1.2 The routing of field-installed conduit and conductors and the location of field-installed devices must not interfere with equipment access of the reading, adjusting, or servicing of any component.
- 1.3 Equipment installation and all starting and control devices must comply with details in equipment submittal drawings and literature.
- 1.4 Contacts and switches are shown in the position they would assume with the circuit deenergized and the chiller shut down.
- 1.5 **WARNING:** Do not use aluminum conductors.
- 1.6 Installer is responsible for any damage caused by improper wiring between starter and chiller.

II POWER WIRING TO STARTER

- 2.0 Provide a means of disconnecting power to the starter.
- 2.1 Power conductor rating must meet minimum unit nameplate voltage and compressor motor RLA (rated load amps).
When 3 conductors are used:
Minimum ampacity per conductor = 1.25 x compressor RLA.
When 6 conductors are used:
Minimum ampacity per conductor = 0.721 x compressor RLA.
- 2.2 Lug adapters may be required if installation conditions dictate that conductors be sized beyond the minimum ampacity required. Contact starter supplier for lug information.
- 2.3 Compressor motor and controls must be grounded by using equipment grounding lugs provided inside starter enclosure.

III CONTROL WIRING

- 3.0 Field supplied control conductors to be at least 18 AWG (American Wire Gage) or larger.
- 3.1 Chilled water and condenser water flow switch contacts, optional remote start device contacts, and optional spare safety device contacts must have 24 vdc rating. Maximum current is 60 mA; nominal current is 10 mA. Switches with gold plated bifurcated contacts are recommended.
- 3.2 Remove jumper wire between 12A and 12B before connecting auxiliary safeties between these terminals.
- 3.3 Pilot relays can control cooler and condenser pump and tower fan motor contactor coil loads rated up to 10 amps at 115 vac or up to 3 amps at 600 vac. Control wiring required for Carrier to start pumps and tower fan motors must be provided to assure chiller protection. If primary pump and tower motor control is by other means, also provide a parallel means for control by Carrier. Do not use starter control transformer as the power source for pilot relay loads.
- 3.4 Do not route control wiring carrying 30 v or less within a conduit which has wires carrying 50 v or higher or alongside wires carrying 50 v or higher.

- 3.5 Voltage selector switch in chiller power panel is factory set for 115 v control and oil heater power source. The 230 v position is not used. If switch is set to 230 v position, oil heater will not operate.
- 3.6 Control wiring cables between starter and power panel must be shielded with minimum rating of 600 v, 80 C. Ground shield at starter. Starter Management Module (SMM) communication cable must be separate.
- 3.7 If optional oil pump circuit breaker is not supplied within the starter enclosure as shown, it must be located within sight of the chiller with wiring routed to suit.
- 3.8 Voltage to terminals LL1 and LL2 comes from a control transformer in a starter built to Carrier specifications. Do not connect an outside source of control power to the compressor motor starter (terminals LL1 and LL2). An outside power source will produce dangerous voltage at the line side of the starter, because supplying voltage at the transformer secondary terminals produces input level voltage at the transformer primary terminals.
- 4.0 Medium voltage (over 600 volts) compressor motors have 3 terminal connections (lead hooks). Use suitable splice connectors and insulation for high-voltage alternating current cable terminations (these items are not supplied by Carrier). Compressor motor starter must have nameplate stamped to conform with Carrier requirement Z-375.
- 4.1 Power conductor rating must meet minimum unit nameplate voltage and compressor motor RLA. (Conductor as defined below may be a single lead or multiple smaller ampacity leads in parallel for the purpose of carrying the equivalent or higher current of a single larger lead.) When 3 conductors are used:
Minimum ampacity per conductor = 1.25 x compressor RLA.
- 4.2 When more than one conduit is used to run conductors from starter to compressor motor terminal box, an equal number of leads from each phase (conductor) must be in each conduit to prevent excessive heating (e.g., conductors to motor terminals 1, 2, and 3 in one conduit, and those to 1, 2, and 3 in another).
- 4.3 Compressor motor power connections can be made through top, top rear, or sides of compressor motor terminal box using holes cut by contractor to suit conduit. Flexible conduit should be used for the last few feet to the terminal box for unit vibration isolation. Use of stress cones may require an over-size (special) motor terminal box (not supplied by Carrier).
- 4.4 Compressor motor frame to be grounded in accordance with the National Electrical Code (NFPA-70) and applicable codes. Means for grounding compressor motor is 2 ground pads, one each located near each motor foot opposite the shaft end.
- 4.5 Do not allow motor terminals to support weight of wire cables. Use cable supports and strain reliefs as required.

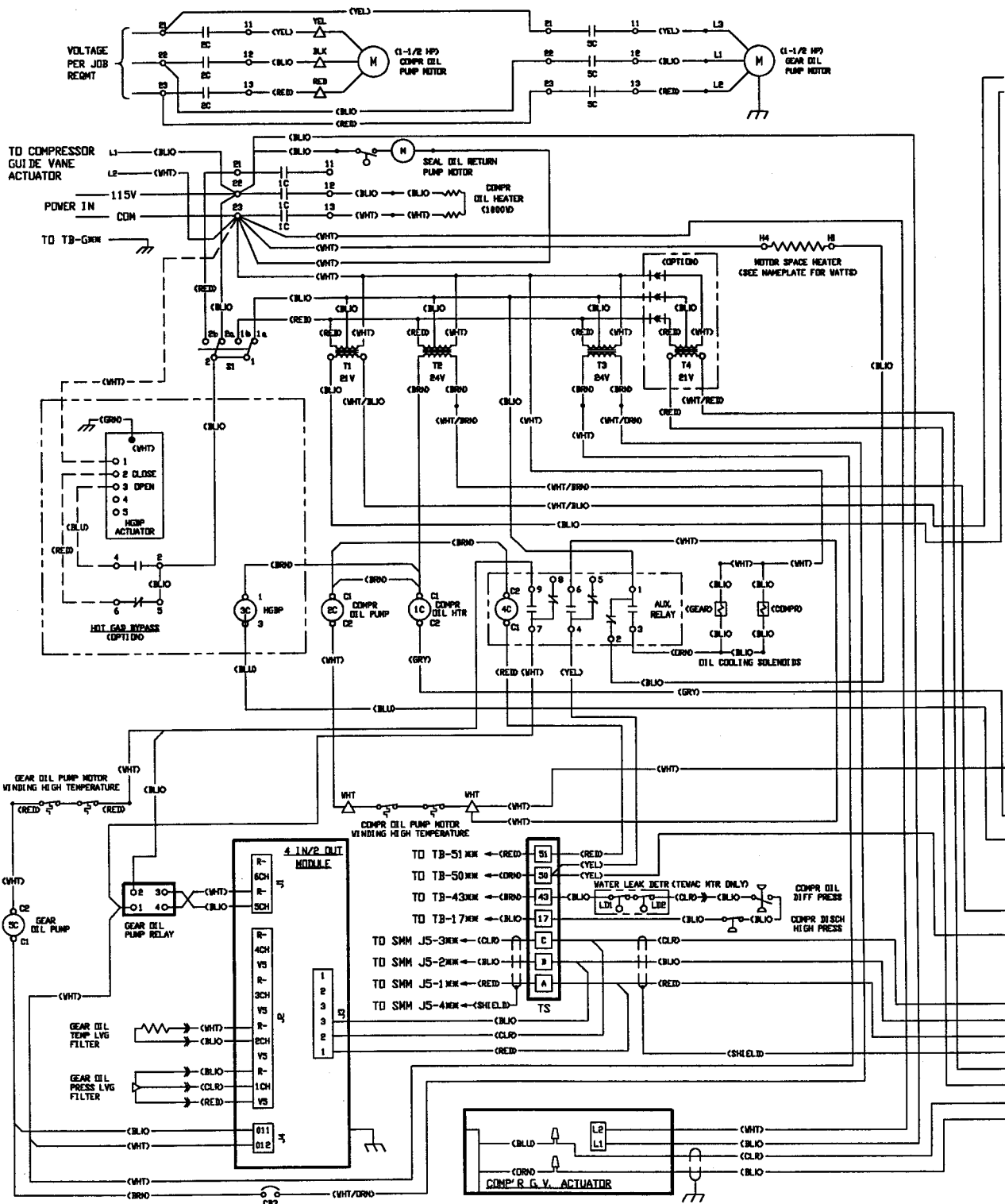

- LEGEND**
- | | | | | | |
|--------|-------------------|-------|------------------|-----|--------------------------|
| BRG | — Bearing | DIFF | — Differential | INT | — Internal |
| C | — Contactor | DISCH | — Discharge | J | — Junction |
| CB | — Circuit Breaker | ENT | — Entering | K | — Relay Designation |
| CH | — Channel | EVAP | — Evaporator | L | — Line Terminal |
| COM | — Communications | EXT | — External | LD | — Leak Detector |
| COMP'R | — Compressor | G.V. | — Guide Vane | LID | — Local Interface Device |
| COND | — Condenser | HGBP | — Hot Gas Bypass | LVG | — Leaving |
| DETR | — Detector | HTR | — Heater | M | — Motor |

Fig. 16 — Typical Control Wiring

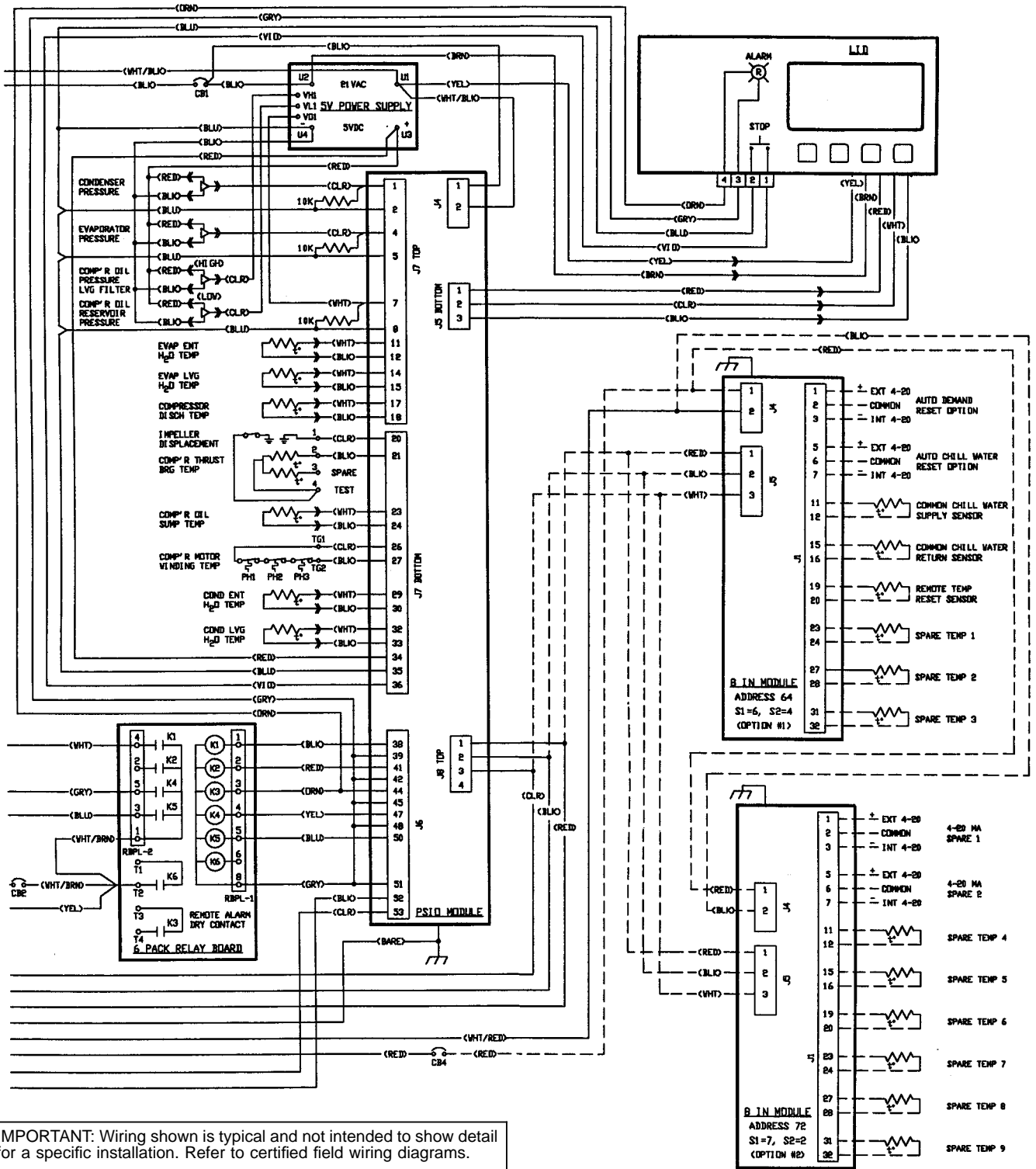

IMPORTANT: Wiring shown is typical and not intended to show detail for a specific installation. Refer to certified field wiring diagrams.

- PH — Phase
- PRESS. — Pressure
- PSIO — Processor/Sensor Input/Output Module
- R — Terminal Designation
- SMM — Starter Management Module
- T — Terminal
- t* — Thermistor
- TB — Terminal Block

- TEMP — Temperature
- TEWAC — Totally Enclosed Water-to-Air Cooled
- TG — Terminal Designation
- TS — Terminal Strip
- (thick line) — Required Power Wiring
- (thin line) — Required Control Wiring
- - - - Options Wiring

Fig. 16 — Typical Control Wiring (cont)

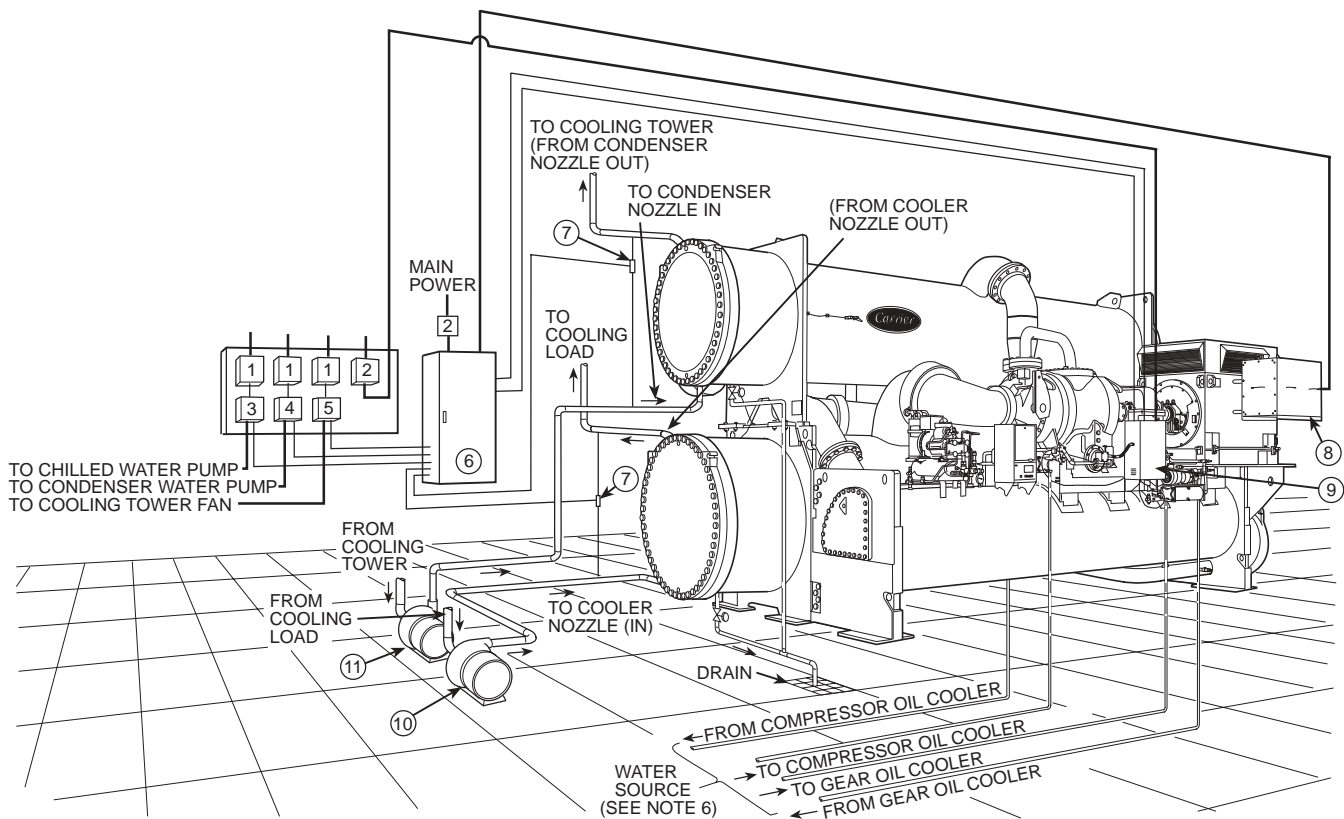

LEGEND

- 1 — Disconnect
 - 2 — Oil Pump Disconnect (See Note 5)
 - 3 — Chilled Water Pump Starter
 - 4 — Condenser Water Pump Starter
 - 5 — Cooling Tower Fan Starter
 - 6 — Free-Standing Compressor Motor Starter
 - 7 — Differential Pressure Switch
 - 8 — Compressor Motor Terminal Box
 - 9 — Chiller Auxiliary Power Panel
 - 10 — Chilled Water Pump
 - 11 — Condenser Water Pump
- Piping
 Control Wiring
 Power Wiring

NOTES:

1. Wiring and piping shown are for general point-of-connection only and are not intended to show details for a specific installation. Certified field wiring and dimensional diagrams are available on request.
2. All wiring must comply with applicable codes.
3. Refer to Carrier System Design Manual for details regarding piping techniques.
4. Wiring not shown for optional devices such as:
 - Remote Start/Stop
 - Remote Alarms
 - Optional Safety Device
 - 4 to 20 mA Resets
 - Optional Remote Sensors
5. Oil pump disconnect may be located within the enclosure of Item 6 — Free-standing Compressor Motor Starter.
6. Both the gear oil cooler and the compressor oil cooler must be connected to a water source that can deliver sufficient water-side pressure drop through the oil coolers to facilitate the required oil cooler water flow. For example, the water source must meet the following minimum requirements:

SUPPLY TEMPERATURE OF OIL-COOLING WATER	AVAILABLE PRESSURE DROP* (Compressor)	AVAILABLE PRESSURE DROP* (Gear)
85 F (29.4 C)	28.6 psi (197.1 kPa)	13.8 psi (95.2 kPa)
70 F (21.1 C)	19.9 psi (137.2 kPa)	8.8 psi (60.7 kPa)
55 F (12.8 C)	12.1 psi (83.4 kPa)	4.4 psi (30.3 kPa)
40 F (4.4 C)	5.8 psi (39.9 kPa)	1.2 psi (8.3 kPa)

*As measured from the oil cooler inlet to the oil cooler outlet.

Fig. 17 — Typical Piping and Wiring for 17EX Chiller (With Free-Standing Starter)

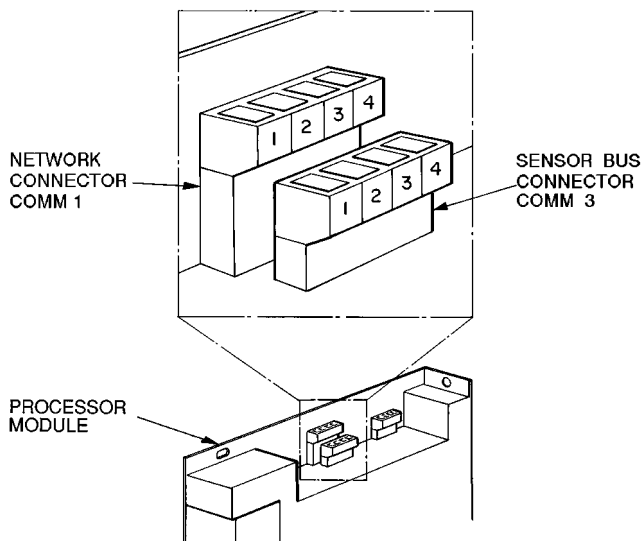

Fig. 18 — Carrier Comfort Network Communication Bus Wiring

When connecting the CCN communication bus to a system element, a color code system for the entire network is recommended to simplify installation and checkout. The following color code is recommended:

SIGNAL TYPE	CCN BUS CONDUCTOR INSULATION COLOR	COMM1 PLUG PIN NO.
+	Red	1
Ground	White	2
-	Black	3

If a cable with a different color scheme is selected, a similar color code should be adopted for the entire network.

At each system element, the shields of its communication bus cables must be tied together. If the communication bus is entirely within one building, the resulting continuous shield must be connected to ground at only one point. See Fig. 19. If the communication bus cable exits from one building and enters another, the shields must be connected to ground at the lightning suppressor in each building where the cable enters or exits the building (one point only).

To connect the 17EX chiller to the CCN network, proceed as follows (Fig. 19):

1. Disconnect power to the PIC (Product Integrated Control) panel.
2. Remove the COMM1 plug from the processor module.
3. Cut a CCN wire and strip the ends of the RED, WHITE, and BLACK conductors.
4. Using a wirenut, connect the drain wires together.
5. Insert and secure the RED wire to Terminal 1 of the COMM1 plug.
6. Insert and secure the WHITE wire to Terminal 2 of the COMM1 plug.
7. Insert and secure the BLACK wire to Terminal 3 of the COMM1 plug.
8. Attach the COMM1 plug back onto the processor module.
9. Mount a terminal strip in a convenient location.
10. Connect the opposite ends of each conductor to separate terminals on the terminal strip.
11. Attach the CCN wiring:
 - a. Connect the RED wire to the matching location on the terminal strip.
 - b. Connect the WHITE wire to the matching location on the terminal strip.
 - c. Connect the BLACK wire to the matching location on the terminal strip.

Install Field Insulation

⚠ CAUTION

Protect insulation from weld heat damage and weld splatter. Cover with wet canvas cover during water piping installation.

When installing insulation at the job site, insulate the following components (see Table 13 and Fig. 20):

- cooler shell
- cooler tube sheets
- suction piping
- oil reclaim tube
- cooler liquid supply piping
- hot gas bypass
- economizer/storage vessel shell
- economizer/storage vessel end plate
- economizer/storage vessel low-side float chamber
- compressor vent line to cooler

Additional insulation of condenser and compressor components and lines may be necessary to prevent condensation on these components.

NOTE: Carrier does not provide waterbox insulation. Insulation of the waterbox covers must be field supplied at the jobsite. When insulating the waterbox covers, allow enough room for removal of the waterbox covers during servicing.

FACTORY INSULATION (Optional) — Optional factory insulation is available for the evaporator shell and tube sheets, suction pipe, and refrigerant drain line(s). Insulation applied at the factory is $\frac{3}{4}$ in. (19.0 mm) thick and has a thermal conductivity K value of:

$$0.28 \frac{\text{Btu} \cdot \text{in.}}{\text{hr} \cdot \text{ft}^2 \cdot \text{°F}} \quad (0.0404 \frac{\text{W}}{\text{m}} \text{ °C})$$

Insulation conforms with UL Standard 94, Classification 94 HBF.

Table 13 — Insulation Requirements
Sheet Foam Insulation

COMPONENT	ft ²	m ²
Cooler Shell (Sizes 45-48)*	374	34.7
Economizer Low Side Float Chamber	48	4.5
Economizer Main Shell with cooler sizes 45-48)	115	10.1
Suction Line	25	2.3
Cooler Marine Waterbox (1 or 3 pass)	158	14.7
Cooler Marine Waterbox (2 pass)	123	11.4
Cooler NIH Waterbox	88	8.2

*The 374 sq ft (34.8 m²) total includes 134 sq ft (12.5 m²) of tube sheet insulation.

Foam Tubing Insulation

TYPE	ft	m
1 1/8" Foam Tubing	9	2.7
1 5/8" Foam Tubing	2	0.6
2" Foam Tubing	9	2.7
5" Foam Tubing	14	4.3

NOTES:

1. Cooler value includes marine waterbox on one end (even-pass arrangement).
2. Values are approximate.
3. Thermal insulation is available as a factory-installed option. Waterbox insulation must be field supplied.

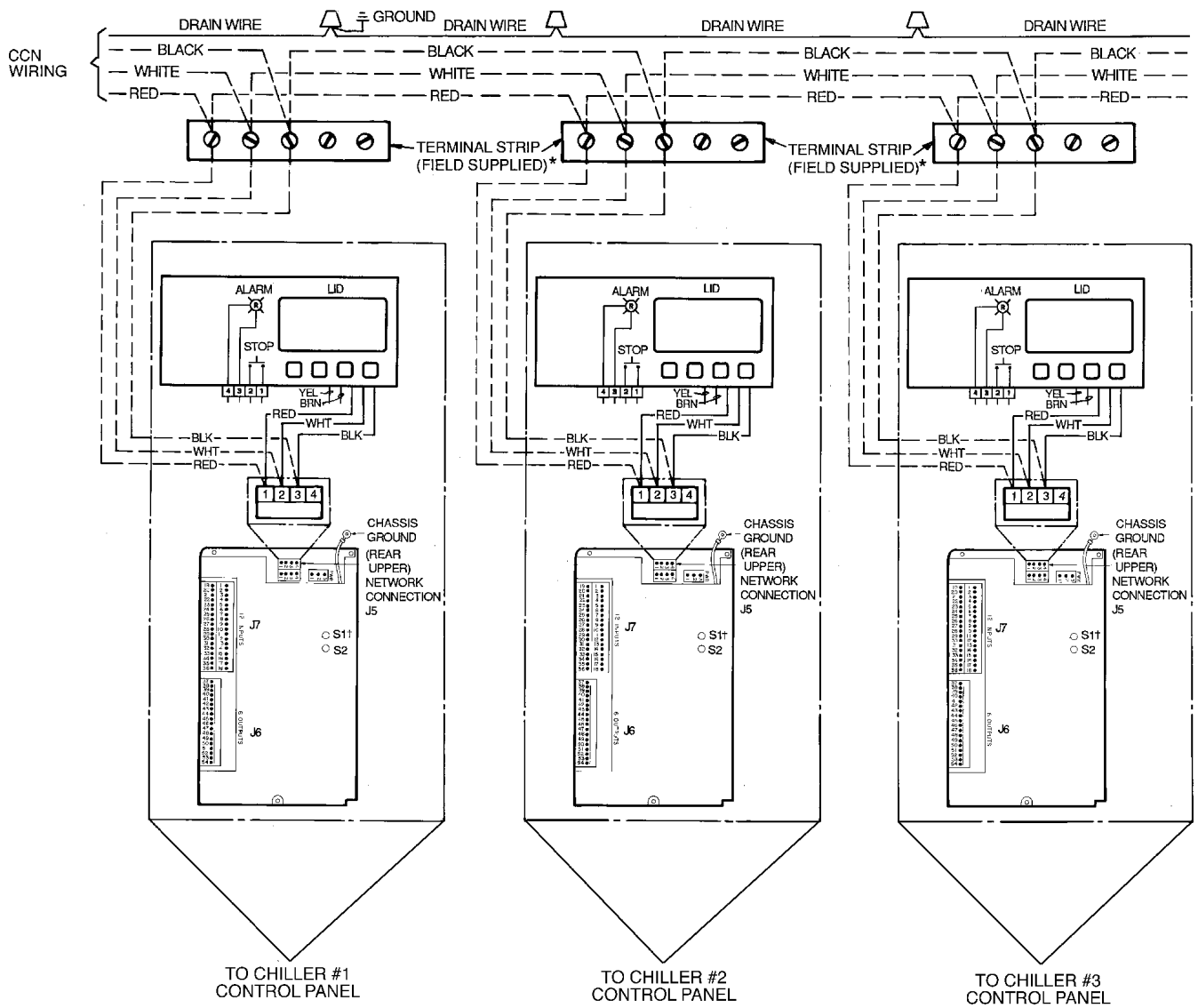

LEGEND

- Factory Wiring
- - - - Field Wiring

*Field-supplied terminal strip must be located in the control center.

†Switches S1 and S2 are factory set on PSIO modules. Do not alter the switches.

Fig. 19 — Typical COMM1 CCN Communication Wiring for Multiple 17EX Chillers

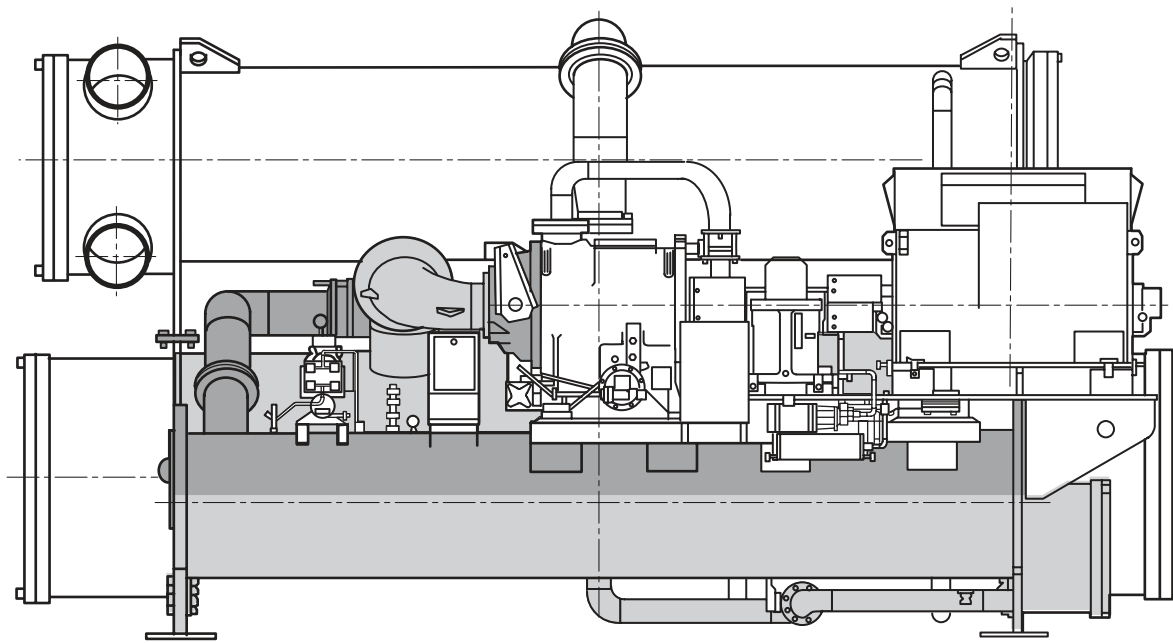

COMPRESSOR END

FRONT VIEW

DRIVE END

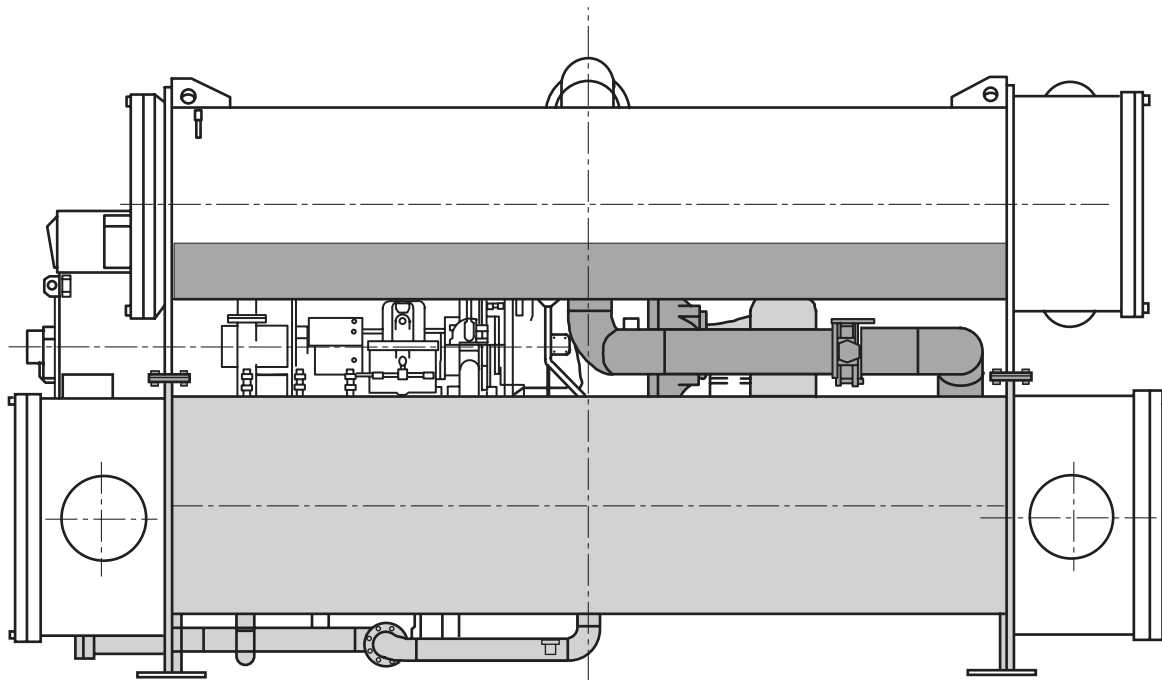

DRIVE END

REAR VIEW

COMPRESSOR END

 — Area must be factory or field insulated.

 — Area to be field insulated, if required.

NOTE: Waterbox covers are to be insulated by the contractor.

Fig. 20 — Typical Insulation Area

INSTALLATION START-UP REQUEST CHECKLIST

Chiller Model Number: 17EX

Serial Number: _____

To: _____

Date _____

Project Name _____

Attn: _____

Carrier Job Number _____

The following information provides the status of the chiller installation.

	YES/NO (N/A)	DATE TO BE COMPLETED
1. The chiller is level.	_____	_____
2. The chiller components are installed and connected in accordance with the installation instructions.	_____	_____
3. The isolation package and grouting (if necessary) are installed.	_____	_____
4. The relief valves are piped to the atmosphere.	_____	_____
5. All piping is installed and supported. Direction of flow is indicated in accordance with the installation instructions and job prints.		
a. Chilled water piping	_____	_____
b. Condenser water piping	_____	_____
c. Waterbox drain piping	_____	_____
d. Pumpout unit condenser piping (if installed)	_____	_____
e. Compressor and gear oil cooler water piping	_____	_____
f. Other _____	_____	_____
6. Gages are installed as called for on the job prints required to establish design flow for the cooler and condenser.		
a. Water pressure gages IN and OUT	_____	_____
b. Water temperature gages IN and OUT	_____	_____
7. The chiller's starter wiring is complete. The wiring is installed per installation instructions and certified prints.		
a. Power wiring to compressor motor. (Motor leads will not be taped until the Carrier technician megger-tests the motor.)	_____	_____
b. Compressor and gear oil pump wiring	_____	_____
c. Oil heater/control wiring	_____	_____
d. Internal motor space heater	_____	_____
d. Other _____	_____	_____
8. The motor starter has not been supplied by Carrier. It has been installed according to the manufacturer's instructions.	_____	_____
9. The motor starter has not been supplied by Carrier and it has been checked for proper operation.	_____	_____
10. The SMM (Starter Management Module) has been installed per Carrier Specification Z-375.	_____	_____

COMMENTS:

Manufacturer reserves the right to discontinue, or change at any time, specifications or designs without notice and without incurring obligations.

