



# **CELESTRON AZ 102** T E L E S C O P E

INSTRUCTION MANUAL

Model #22159 -DS

## WHAT'S IN THE BOX

We recommend saving your telescope box so it can be used to store the telescope when it is not in use. Unpack the box carefully as some parts are small. Use the parts list below to verify that all parts and accessories are present.

### PARTS LIST

---



**NOTE:** Smartphone not included.

### SOLAR WARNING

---

- Never look directly at the Sun with the naked eye or with a telescope unless you have the proper solar filter. Permanent and irreversible eye damage may result.
- Never use your telescope to project an image of the Sun onto any surface. Internal heat build-up can damage the telescope and any accessories attached to it.
- Never use an eyepiece solar filter or a Herschel wedge. Internal heat build-up inside the telescope can cause these devices to crack or break, allowing unfiltered sunlight to pass through to the eye.
- Do not leave the telescope unsupervised, especially when children or adults unfamiliar with the correct operating procedures of your telescope are present.

# ASSEMBLING YOUR TELESCOPE

## THE MOUNT

---

The AZ mount and tripod come fully assembled, so setting it up is easy.

1. Remove the tripod and mount from the box.
2. Loosen the hand knobs at the bottom of each leg and extend the inner section of the leg to the desired length. Tighten the knobs to secure the legs, being careful not to over tighten.
3. Stand the tripod upright and pull the tripod legs apart until the center brace snaps into place.
4. Place the accessory tray on top of the center brace and line up the threaded post on the bottom of the tray with the hole in the top of the center leg brace. Rotate the tray clockwise until it is secure.
5. Make sure the leg hinge bolts are secure by snugging down the black thumbnuts at the top of each leg.



## ADJUSTING THE ANGLE OF THE MOUNT ARM

---

Depending on your specific use of the telescope, you may wish to change the angle of the mount arm to give you additional range of motion. The mount comes set up for the astronomical use; it can move upward but is limited in its downward motion. If you are using the mount for terrestrial observation from an elevated location (cliff top, balcony, etc.) and you want to point the scope well below the horizon, you will need to change the angle of the mount arm to accommodate this.

To make this adjustment:

1. Unthread the round cover on the bottom of the vertical arm of the mount.
2. Using a 4mm hex-key wrench (user supplied), remove the three screws under the cover.
3. Rotate the mount arm so that it is pointed straight up and thread the three screws back in.
4. Tighten the screws and replace the round cover.



## THE SLOW MOTION KNOBS

---

To attach the slow motion knobs to your mount:

1. Locate the supplied hex key hidden inside the slot in the front of your mount.
2. Place the slow motion control knob over the D-shaped gear shaft and push inward to make sure it is fully seated.
3. Use the hex key to tighten the setscrews onto the gear shaft.
4. Return the hex key to its storage position in the front of the mount.



## THE TELESCOPE TUBE

---

To attach the telescope tube to your tripod and mount:

1. Locate the dovetail bar mounted on the side of the telescope tube.
2. Holding the telescope tube next to the mount, slide the dovetail bar into the clamp at the top of the mount.
3. Tighten the hand knob on the bottom of the clamp to secure the telescope in place.



## THE STAR DIAGONAL

---

The star diagonal attaches to the back of a refracting telescope and contains a small prism that reflects light at a 90° angle, providing a more comfortable viewing position. Because a star diagonal gives you a 100% correctly oriented image, you can easily use the telescope for daytime terrestrial observing.

To insert the diagonal:

1. Remove the caps from both sides of the diagonal.
2. Loosen the setscrews on the back of the focuser and pull out the small dust cap.
3. Insert the smaller tube on the diagonal into the back of the focuser and secure it by tightening the setscrews.

You can rotate the diagonal to any position by loosening the setscrews.



## THE EYEPIECE

Your telescope comes with a 10mm and 20mm Kellner eyepieces. Additional eyepieces can be purchased to increase or decrease the magnification to your desired level.

1. Loosen the set screws on the open end of the star diagonal.
2. Insert the silver barrel of the 20mm eyepiece into the star diagonal.
3. Tighten the setscrews to secure the eyepiece
4. To see the sharpest image possible, focus by looking through the eyepiece and slowly turning the focusing knobs until the image comes into sharp focus.



## THE STARPOINTER FINDERSCOPE

Your telescope comes with a StarPointer finderscope that you will use as a sighting tool when aiming the telescope at a target. Your StarPointer finderscope is shipped with a clear plastic tab inserted between the battery and the contact to prevent the battery from accidentally being discharged in shipment. Pull this tab out before using your finderscope.

To install the finderscope:

1. Slide the finderscope bracket into the dovetail slot on the telescope tube near the focuser. The large window on the finder should be facing the front of the telescope.
2. Secure the bracket by tightening the setscrew on the dovetail slot.



## BATTERY ACCESS INSTRUCTIONS

The StarPointer finderscope is powered by a long life 3V lithium battery (#CR2032) located directly under the StarPointer's front end.

To access the battery compartment, turn the StarPointer upside down. Using a Phillips head screwdriver, loosen the screw and lift up the battery cover. When replacing the battery, make sure to install the new battery with its positive terminal (+) facing outward. If the telescope will not be in use for a long period of time, it is recommended to remove the battery from the StarPointer.

**WARNING: KEEP BATTERIES OUT OF REACH OF CHILDREN.**

- Examine devices and make sure the battery compartment is correctly secured, e.g. that the screw or other mechanical fastener is tightened.
- Do not use if compartment is not secure.
- Dispose of used button batteries immediately and safely. Flat batteries can still be dangerous.
- Tell others about the risk associated with button batteries and how to keep their children safe.



## MOVING THE TELESCOPE

The AZ mount has slip clutches in both axes. To make large movements with the telescope, simply hold the optical tube and push it in the desired direction. To make fine adjustments or to track celestial objects, turn both slow motion knobs.

## ALIGNING THE STARPOINTER FINDERSCOPE

---

The StarPointer finderscope helps you aim your telescope by looking through its round glass window and covering your target with the red reticle projected in the window.

The first time you assemble your telescope, you'll need to align the finderscope with the main optics of the telescope. Although this step can be done at night, it is significantly easier during the day. Once you have completed the finderscope alignment, you should not have to repeat this step unless the finderscope is bumped or dropped.

1. Take the telescope outside during the day. Using your naked eye, find an easily recognizable object, such as a streetlight, car license plate, or tall tree. The object should be as far away as possible, but at least a quarter mile away.
2. Remove the main dust cover from the telescope and make sure your 20mm eyepiece is installed.
3. Move the telescope left and right or up and down so that it is roughly pointing toward the object you chose in step 1.
4. Look through the telescope's eyepiece and manually move the telescope until the object you chose lies in the center of the view. If the image is blurry, gently turn the focus knobs until it comes into sharp focus.
5. Once the object is centered in your 20mm eyepiece, turn on the finderscope by turning the power/brightness switch knob on the finderscope as far as it will go.
6. With your head positioned about a foot behind the finder, look through the round window and locate the red dot. It will probably be close to, but not on top of, the object you see when you are looking through the 20mm eyepiece.
7. Without moving the telescope, use the two adjustment knobs on the side and underneath the finderscope. One controls the left-right motion of the red dot, while the other controls the up-down motion. Adjust both until the red dot appears over the same object you are observing in the 20mm eyepiece.

Now choose some other distant targets to practice aiming your telescope. Look through the StarPointer finderscope window and place the red dot on the target you are trying to view and verify that it is the 20mm eyepiece of the scope.

With your finderscope aligned, your telescope is fully assembled and you are ready to observe!

**NOTE:** Be sure to turn off the StarPointer finderscope when not in use to conserve battery power.

## YOUR FIRST ASTRONOMICAL OBSERVING SESSION

### THE MOON

---

Now you are ready to take your telescope out at night and do some real observing!

Let's start with the Moon. The Moon takes about one month to go through a complete phase cycle, from New Moon to Full Moon and back again. Try observing it at different points during this cycle.

While you can observe the Moon any time it is visible in the night sky, the best time to view it is from two days after a New Moon up to a few days before a Full Moon. During this period, you will be able to see the most detail in craters and lunar mountain ranges. Consult a calendar to find out when the next New Moon will be.

1. With a clear view of the Moon, set up your telescope with the 20mm eyepiece.
2. Turn on the finderscope and look through it to find the red reticle.
3. Move the telescope until you can see the Moon through the finderscope's window and the reticle is centered on the Moon.
4. Look through the 20mm eyepiece. Gently turn the focus knobs to adjust the sharpness of the image.

### CONGRATULATIONS! YOU HAVE NOW OBSERVED YOUR FIRST CELESTIAL OBJECT!

To get a closer view of the Moon, replace the 20mm eyepiece with the 10mm eyepiece. It will give you more magnification, making the Moon appear much larger. You may need to adjust the focus knobs when you change eyepieces to ensure you are getting the sharpest image.

You can view many other celestial objects, such as planets, star clusters and nebulae using this same basic technique.

## INSTALLING THE SMARTPHONE ADAPTER

1. Open the eyepiece clamp and place it around the body of the eyepiece. Tighten the clamp until it is secure.
2. Use the phone clamp knob to open the phone holder until your phone fits inside. Tighten it to secure your phone in place.
3. Turn on the phone and open your camera app. Make sure the flash is turned off.
4. Loosen the knob on the bottom of the adapter that secures the phone clamp to the eyepiece clamp. Slide the phone clamp up and down and rotate it left and right until your camera is looking down through the eyepiece of the telescope. Tighten the knob on the bottom of the adapter to secure it in place.
5. Use the telescopes focuser to adjust focus of your camera. Snap the image using your app.

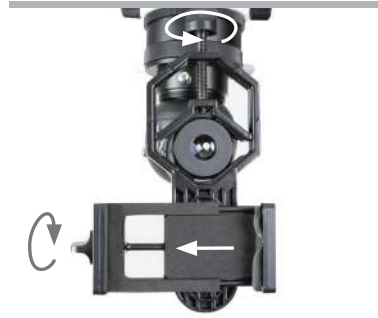

## USING THE BLUETOOTH REMOTE



To insert or replace the battery, place your thumb in the center of the back cover, pressing inward and sliding downward remove the battery door. The CR2032 battery should be inserted with the positive (+) side facing upward. Replace the cover.

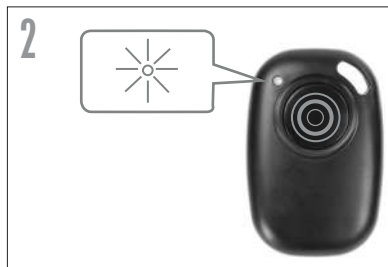

Press and hold the button on the remote for 5 seconds. A blue light will turn on and, after a few seconds, start to blink. The remote is now in pairing mode.

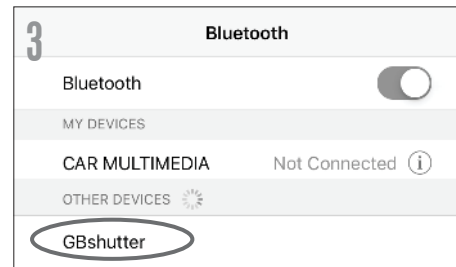

Using the Bluetooth settings on your phone, pair the device called "GBshutter."



Open your camera app. Press the button on the remote to trigger the shutter on your phone.



If your camera is in video mode, you can press the button once to start recording and again to stop the recording.

# CELESTRON TWO YEAR LIMITED WARRANTY

**A.** Celestron warrants your product to be free from defects in materials and workmanship for two years. Celestron will repair or replace such product or part thereof which, upon inspection by Celestron, is found to be defective in materials or workmanship. As a condition to the obligation of Celestron to repair or replace such product, the product must be returned to Celestron together with proof-of-purchase satisfactory to Celestron.

**B.** The Proper Return Authorization Number must be obtained from Celestron in advance of return. Please submit your request to Celestron's online technical support center at <https://www.celestron.com/pages/technical-support> to receive the number to be displayed on the outside of your shipping container.

All returns must be accompanied by a written statement setting forth the name, address, and daytime telephone number of the owner, together with a brief description of any claimed defects. Parts or product for which replacement is made shall become the property of Celestron.

The customer shall be responsible for all costs of transportation and insurance, both to and from the factory of Celestron, and shall be required to prepay such costs.

Celestron shall use reasonable efforts to repair or replace any product covered by this warranty within thirty days of receipt. In the event repair or replacement shall require more than thirty days, Celestron shall notify the customer accordingly. Celestron reserves the right to replace any product which has been discontinued from its product line with a new product of comparable value and function.

This warranty shall be void and of no force or effect in the event a covered product has been modified in design or function, or subjected to abuse, misuse, mishandling or unauthorized repair. Further, product malfunction or deterioration due to normal wear is not covered by this warranty.

CELESTRON DISCLAIMS ANY WARRANTIES, EXPRESSED OR IMPLIED, WHETHER OF MERCHANTABILITY OR FITNESS FOR A PARTICULAR USE, EXCEPT AS EXPRESSLY SET FORTH HEREIN. THE SOLE OBLIGATION OF CELESTRON UNDER THIS LIMITED WARRANTY SHALL BE TO REPAIR OR REPLACE THE COVERED PRODUCT, IN ACCORDANCE WITH THE TERMS SET FORTH HEREIN. CELESTRON EXPRESSLY DISCLAIMS ANY LOST PROFITS, GENERAL, SPECIAL, INDIRECT OR CONSEQUENTIAL DAMAGES WHICH MAY RESULT FROM BREACH OF ANY WARRANTY, OR ARISING OUT OF THE USE OR INABILITY TO USE ANY CELESTRON PRODUCT. ANY WARRANTIES WHICH ARE IMPLIED AND WHICH CANNOT BE DISCLAIMED SHALL BE LIMITED IN DURATION TO A TERM OF TWO YEARS FROM THE DATE OF ORIGINAL RETAIL PURCHASE.

Some states do not allow the exclusion or limitation of incidental or consequential damages or limitation on how long an implied warranty lasts, so the above limitations and exclusions may not apply to you.

This warranty gives you specific legal rights, and you may also have other rights which vary from state to state. Celestron reserves the right to modify or discontinue, without prior notice to you, any model or style product. If warranty problems arise, or if you need assistance in using your product, please visit Celestron's online technical support center at <https://www.celestron.com/pages/technical-support>.

**NOTE:** This warranty is valid to U.S.A. and Canadian customers who have purchased this product from an authorized Celestron dealer in the U.S.A. or Canada. Warranty outside the U.S.A. and Canada is valid only to customers who purchased from a Celestron's International Distributor or Authorized Celestron Dealer in the specific country. Please contact them for any warranty service.

## SAFETY INSTRUCTIONS

- Risk of explosion if battery is replaced by an incorrect type.
- The included battery is not rechargeable.
- Please use the battery in its original purpose to avoid causing the battery to short circuit. When the conductive material is connected directly to the battery positive and negative will cause a short circuit.
- Do not use a damaged battery.
- Keeping the battery in an extremely cold or very hot location can result in shortened battery life.
- When replacing the battery, please refer to the instruction manual and pay attention to the positive and negative direction of battery.
- Do not put the battery in the fire. Dispose of the battery according to local regulations.

## FCC IDENTIFIER: 2A2FG-X9

This device complies with Part 15 of the FCC Rules. Operation is subject to the following two conditions: (1) This device may not cause harmful interference, and (2) this device must accept any interference received, including interference that may cause undesired operation.

**CAUTION:** Changes or modifications not expressly approved by the party responsible for compliance could void the user's authority to operate the equipment.

**NOTE:** This equipment has been tested and found to comply with the limits for a Class B digital device, pursuant to part 15 of the FCC Rules. These limits are designed to provide reasonable protection against harmful interference in a residential installation.

This equipment generates, uses and can radiate radio frequency energy and, if not installed and used in accordance with the instructions, may cause harmful interference to radio communications. However, there is no guarantee that interference will not occur in a particular installation.

If this equipment does cause harmful interference to radio or television reception, which can be determined by turning the equipment off and on, the user is encouraged to try to correct the interference by one or more of the following measures:

- Reorient or relocate the receiving antenna.
- Increase the separation between the equipment and receiver.
- Connect the equipment into an outlet on a circuit different from that to which the receiver is connected.
- Consult the dealer or an experienced radio/TV technician for help.

Product design and specifications are subject to change without prior notification. This product is designed and intended for use by those 14 years of age and older.



© 2022 Celestron • All rights reserved  
[celestron.com/pages/technical-support](https://www.celestron.com/pages/technical-support)  
2835 Columbia Street • Torrance, CA 90503 U.S.A.



22159-DS

11-21