

Light Assembly Installation

1. Remove the Corner/Head/Tail light from the vehicle.
2. Select a location to mount the lighthouse.
3. Drill an 1 inch diameter cut-out on the light assembly.
4. Insert the lighthouse through the double-sided adhesive foam and the cut-out then press firmly for 1 minutes. (Please ensure that the surface is cleaned thoroughly with alcohol before mounting.)
5. Apply silicone (user-supplied) for better seal.

WARNING: DO NOT cover the heatsink with silicone. This may cause damage to the product and void the warranty.

NOTE: Lighthouse mounting location may vary depending on the design of the vehicle light assembly.

OPERATIONS

To +VDC (fuse @ 2A).....**RED**

To Chassis Ground.....**BLACK**

For Synchronization.....**YELLOW**
Connect **YELLOW** wires of all heads together for synchronization (All heads must be set at the same pattern)

For Simultaneous or Alternating Flash:

1. Apply +VDC to **RED** and **YELLOW** wires simultaneously to enter Grouping mode; lighthouse will display short (single or double) flashes:
 - Single flash = Group1
 - Double flash = Group2
2. Remove **YELLOW** wire from +VDC and momentarily apply to +VDC to change Groups:
 - Heads in the same Group flash together.
 - Group1 Heads alternate with Group2 Heads.
3. Disconnect power to save and exit Grouping mode.

For Flash Patterns:

Momentarily apply +VDC to **YELLOW** wire:

- once for next pattern
- quickly three times for FP#1

NOTE: This unit may not be factory set at FP# 1.

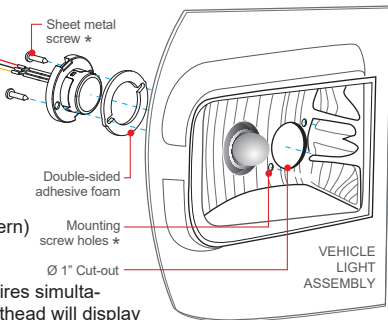

* Not applicable when mounting with Double-sided Adhesive Foam

FP#	Flash Patterns		
1	Random	7	Quad
2	Steady	8	Quint
3	Single	9	Ultra
4	Mega	10	Single-Quad
5	Double	11	Single H/L
6	Triple	12	Single-Triple-Quint

Bezel Mount Installation

1. Use the mounting foam to mark wire and screw holes before drilling.
2. Carefully drill marked holes accordingly.
3. Insert lighthouse wires through the mounting foam and into the wire hole.
4. Secure the lighthouse with supplied sheet metal screws.
5. Mount the snap-on bezel onto the lighthouse.

NOTE: Make sure to use the foam when mounting the lighthouse.

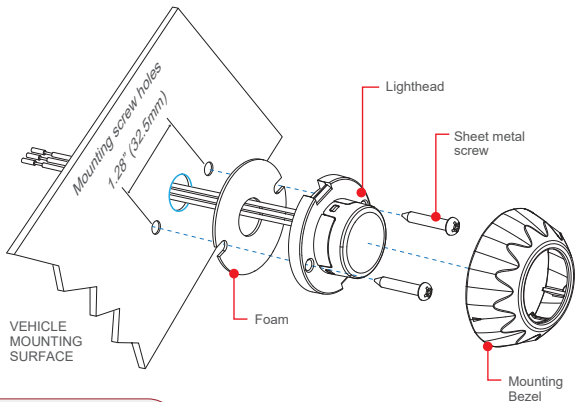

BEZEL REMOVAL

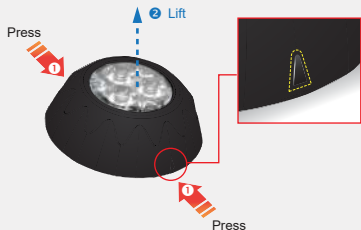

❶ Apply pressure on both sides marked with triangle.

❷ Lift the bezel to remove.

NOTE: Avoid from multiple mount and removal of the bezel to prevent loose fit.