

CHAMPION

POWER EQUIPMENT TM-MC

OWNER'S MANUAL & OPERATING INSTRUCTIONS

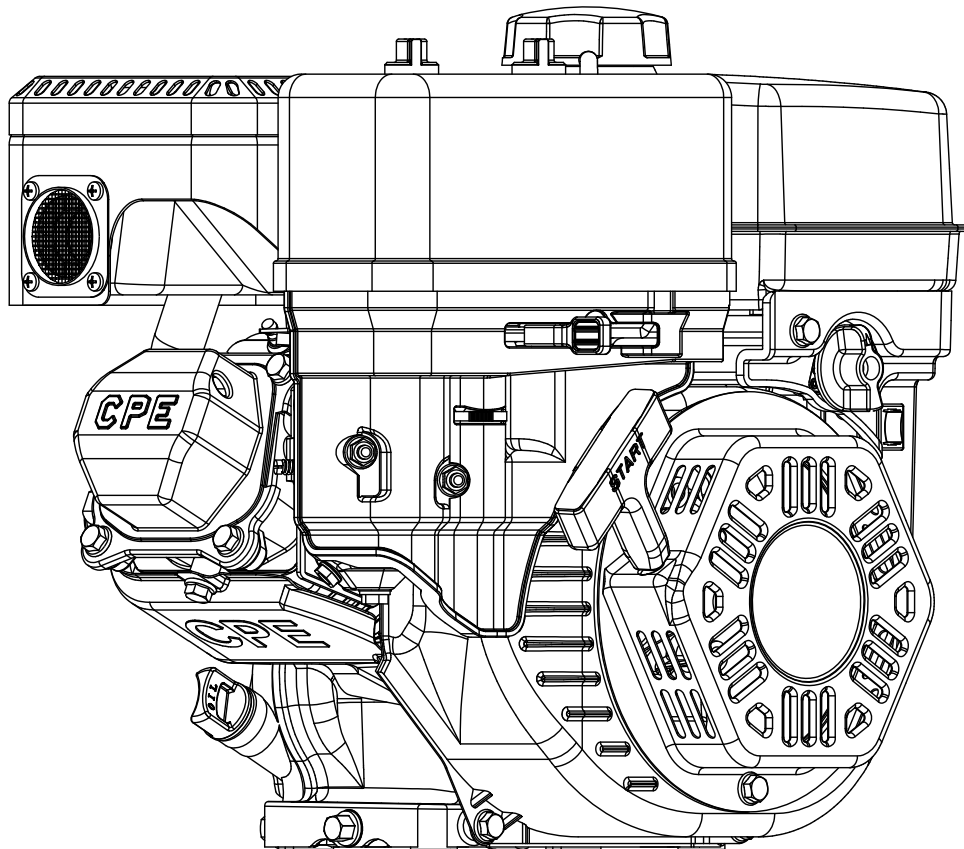

196cc REPLACEMENT ENGINE



MODEL NUMBER
100220

SAVE THESE INSTRUCTIONS
Important Safety Instructions
are included in this manual.

MADE IN CHINA
REV 100220-20180509

12039 Smith Ave.
Santa Fe Springs CA 90670
USA / 1-877-338-0999
www.championpowerequipment.com

AN IMPORTANT MESSAGE ABOUT TEMPERATURE:

Your Champion Power Equipment product is designed and rated for continuous operation at ambient temperatures up to 40°C (104°F). When your product is needed your product may be operated at temperatures ranging from -15°C (5°F) to 50°C (122°F) for short periods. If the product is exposed to temperatures outside this range during storage, it should be brought back within this range before operation. In any event, the product must always be operated outdoors, in a well-ventilated area and away from doors, windows and other vents.

Have questions or need assistance?

Do not return this product to the store!

WE ARE HERE TO HELP!

Visit our website:

www.championpowerequipment.com

for more info:

- Product Info & Updates
- Tech Bulletins
- Frequently Asked Questions
- Product Registration

– or –

Call our Customer Care Team Toll-Free at:

1-877-338-0999

For residents of California:

WARNING: This product contains chemicals known to the State of California to cause cancer or birth defects and other reproductive harm.

WARNING: The engine exhaust from this product contains chemicals known to the State of California to cause cancer and birth defects and other reproductive harm.

*We are always working to improve our products. Therefore, the enclosed product may differ slightly from the image on the cover.

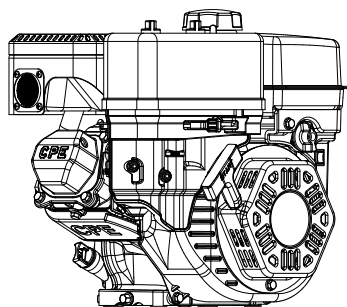

196cc REPLACEMENT ENGINE

TABLE OF CONTENTS

Introduction	1	Troubleshooting	11
Introduction	1	Specifications	12
Manual Conventions	2	Engine Specifications	12
Safety Rules	3	Fuel	12
Controls and Features	5	Oil	12
Replacement Engine	5	Spark Plugs	12
Parts Included	5	Valve Clearance	12
Assembly	6	Keyway Shaft	12
Add Engine Oil	6	Parts Diagram	13
Add Engine Fuel	7	Parts List	14
Operation	8		
Starting the Engine	8		
Stopping the Engine	8		
Operation at High Altitude	8		
Maintenance and Storage	9		
Engine Maintenance	9		
Oil	9		
Spark Plugs	9		
Air Filter	9		
Cleaning	10		
Maintenance Schedule	10		
Storage	10		
Engine Storage	10		

INTRODUCTION

Introduction

Congratulations on your purchase of a Champion Power Equipment product. Champion Power Equipment and Champion Engine Technology designs, builds, and supports all of our products to strict specifications and guidelines. With proper product knowledge, safe use, and regular maintenance, this product should bring years of satisfying service.

Every effort has been made to ensure the accuracy and completeness of the information in this manual, and we reserve the right to change, alter and/or improve the product and this document at any time without prior notice.

Since CPE/CET highly value how our products are designed, manufactured, operated and are serviced, and also highly value your safety and the safety of others, we would like you to take the time to review this product manual and other product materials thoroughly and be fully aware and knowledgeable of the assembly, operation, dangers and maintenance of the product before use. Fully familiarize yourself, and make sure others who plan on operating the product fully familiarize themselves too, with the proper safety and operation procedures before each use. Please always exercise common sense and always err on the side of caution when operating the product to ensure no accidents, property damage, or injury occurs. We want you to continue to use and be satisfied with your CPE/CET product for years to come.

Record the model and serial numbers as well as date and place of purchase for future reference. Have this information available when ordering parts and when making technical or warranty inquiries.

Champion Power Equipment Support
1-877-338-0999
Model Number
100220
Serial Number
Date of Purchase
Purchase Location
For Oil Type see 'Add Engine Oil' section. For Fuel Type see 'Add Fuel' section.

This manual uses the following symbols to help differentiate between different kinds of information. The safety symbol is used with a key word to alert you to potential hazards in operating and owning power equipment.

Follow all safety messages to avoid or reduce the risk of serious injury or death.

 **DANGER**

DANGER indicates an imminently hazardous situation which, if not avoided, **will** result in death or serious injury.

 **WARNING**

WARNING indicates a potentially hazardous situation which, if not avoided, **could** result in death or serious injury.

 **CAUTION**

CAUTION indicates a potentially hazardous situation which, if not avoided, **may** result in minor or moderate injury.

CAUTION

CAUTION used without the safety alert symbol indicates a potentially hazardous situation which, if not avoided, **may** result in property damage.

 **NOTE**

If you have questions regarding your engine, we can help. Please call our help line at **1-877-338-0999**

SAFETY RULES

WARNING

Read this manual thoroughly before operating your engine. Failure to follow instructions could result in serious injury or death.

WARNING

The engine exhaust from this product contains chemicals known to the state of California to cause cancer, birth defects, or other reproductive harm.

DANGER

Engine exhaust contains carbon monoxide, a colorless, odorless, poison gas. Breathing carbon monoxide will cause nausea, dizziness, fainting or death. If you start to feel dizzy or weak, get to fresh air immediately.

Operate engine outdoors only in a well ventilated area DO NOT operate the engine inside any building, including garages, basements, crawlspaces and sheds, enclosure or compartment, including the engine compartment of a recreational vehicle. DO NOT allow exhaust fumes to enter a confined area through windows, doors, vents or other openings. **DANGER CARBON MONOXIDE, using an engine indoors CAN KILL YOU IN MINUTES.**

DANGER

Rotating parts can entangle hands, feet, hair, clothing and/or accessories. Traumatic amputation or severe laceration can result.

Keep hands and feet away from rotating parts. Tie up long hair and remove jewelry. Operate equipment with guards in place. DO NOT wear loose-fitting clothing, dangling drawstrings or items that could become caught.

DANGER

Sparks can result in fire or electrical shock.

When servicing the engine:

Disconnect the spark plug wire and place it where it cannot contact the plug. DO NOT check for spark with the plug removed. Use only approved spark plug testers.

WARNING

Running engines produce heat. Severe burns can occur on contact. Combustible material can catch fire on contact.

DO NOT touch hot surfaces. Avoid contact with hot exhaust gases. Allow equipment to cool before touching. Maintain at least three feet of clearance on all sides to ensure adequate cooling. Maintain at least five feet of clearance from combustible materials.

⚠ WARNING

Rapid retraction of the starter cord will pull hand and arm towards the engine faster than you can let go. Unintentional startup can result in entanglement, traumatic amputation or laceration. Broken bones, fractures, bruises or sprains could result.

When starting engine, pull the starter cord slowly until resistance is felt and then pull rapidly to avoid kickback.

⚠ CAUTION

Improper treatment or use of the engine can damage it, shorten its life and void your warranty.

Use the engine only for intended uses. Operate only on level surfaces. DO NOT expose engine to excessive moisture, dust, or dirt.

DO NOT allow any material to block the cooling slots. DO NOT use the engine if:

- Equipment sparks, smokes or emits flames
- Equipment vibrates excessively

⚠ DANGER

Fuel and fuel vapors are highly flammable and extremely explosive.

Fire or explosion can cause severe burns or death. Unintentional startup can result in entanglement, traumatic amputation or laceration.

When adding or removing fuel:

Turn the engine off and let it cool for at least two minutes before removing the fuel cap. Loosen the cap slowly to relieve pressure in the tank. Only fill or drain fuel outdoors in a well-ventilated area.

DO NOT overfill the fuel tank. Always keep fuel away from sparks, open flames, pilot lights, heat and other sources of ignition. DO NOT light or smoke cigarettes.

When starting the engine:

DO NOT attempt to start a damaged engine. Make certain that the gas cap, air filter, spark plug, fuel lines and exhaust system are properly in place. Allow spilled fuel to evaporate fully before attempting to start the engine.

Make certain that the engine is resting firmly on level ground.

When transporting or servicing the engine:

Make certain that the fuel valve is in the off position and the fuel tank is empty. Disconnect the spark plug wire.

When storing the engine:

Store away from sparks, open flames, pilot lights, heat and other sources of ignition.

CONTROLS AND FEATURES

Read this owner's manual before operating your engine. Familiarize yourself with the location and function of the controls and features. Save this manual for future reference.

Replacement Engine

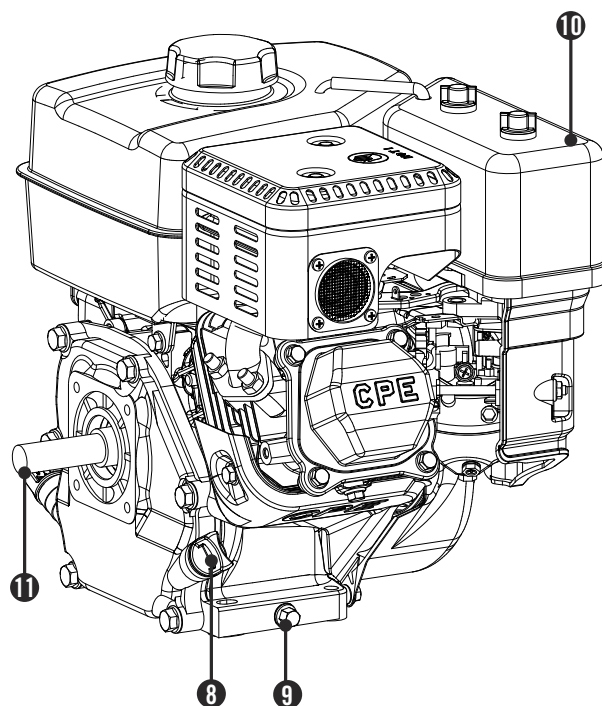
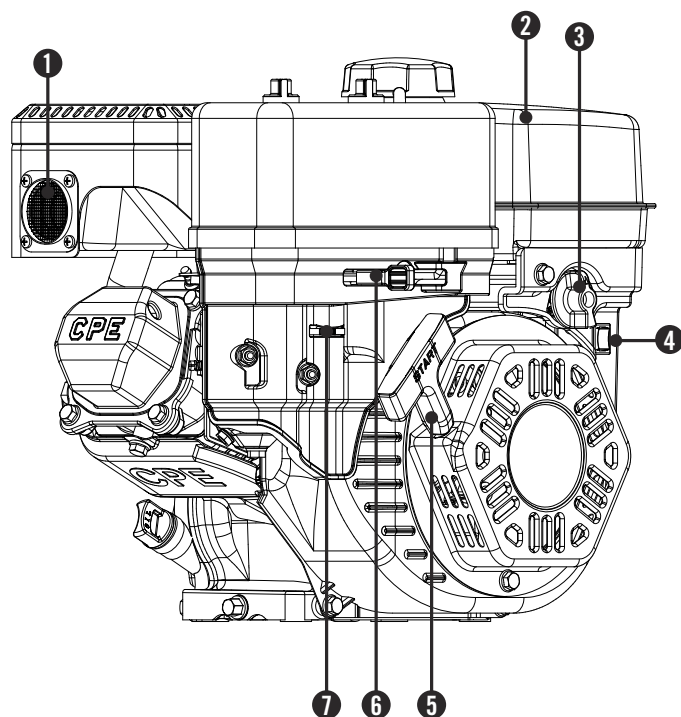

- (1) **Muffler**
- (2) **Fuel Tank** – 0.9 gallons (3.4 L) capacity fuel tank.
- (3) **Fuel Valve Knob** – Turn this valve to the “On” position to supply fuel to the engine.
- (4) **Engine Switch**
- (5) **Recoil Starter** – Used to start the engine.
- (6) **Throttle** – Controls engine speed
- (7) **Choke Lever** – Used to start the engine
- (8) **Oil Filler Cap** – Check and fill engine oil level.
- (9) **Oil Drain Bolt** – Remove to drain engine oil.
- (10) **Air Cleaner** – Protects the engine by filtering dust and debris from the intake air
- (11) **Crank Shaft**

Parts Included

Your 100220 Gasoline Powered Engine ships with the following parts:

Other

- Spark Plug Socket 1



Add Engine Oil

! CAUTION

DO NOT attempt to crank or start the engine before it has been properly filled with the recommended type and amount of oil. Damage to the engine as a result of failure to follow these instructions will void your warranty.

NOTE

The recommended oil type is 10W-30 automotive oil.

1. Place the engine on a flat, level surface.
2. Remove oil fill cap/dipstick to add oil.
3. Using a funnel add up to 0.6 qt. (0.6 L) of oil (not included) and replace oil fill cap/dipstick. DO NOT OVERFILL.
4. Check engine oil level daily and add as needed.

NOTE

Once oil has been added, a visual check should show oil about 1-2 threads from running out of the fill hole. If using the dipstick to check oil level, DO NOT screw in the dipstick while checking.

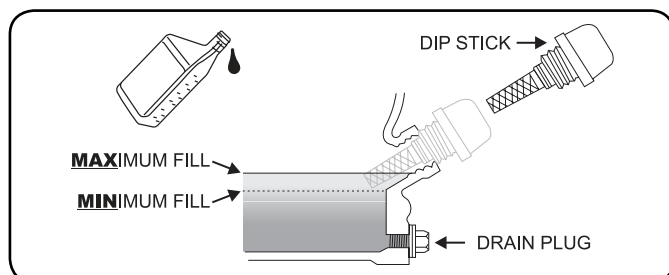

NOTE

Check oil often during the break-in period. Refer to the Maintenance section for recommended service intervals.

Add Engine Oil Cont'd.

CAUTION

The engine is equipped with a low oil shut-off sensor and will stop when the oil level in the crankcase falls below the threshold level.

NOTE

We consider the first 5 hours of run time to be the break-in period for the engine. During the break in period we recommend using standard automotive non-synthetic blended oils. After the break in period synthetic lubricant can be used but is not required. Adjusting throttle setting will increase/decrease engine speed helping to seat piston rings. Avoid bogging or lugging the engine down and avoid prolonged running at constant RPM. After the 5 hour break-in period, change the oil. Using synthetic lubricants does not increase the recommended oil change interval.

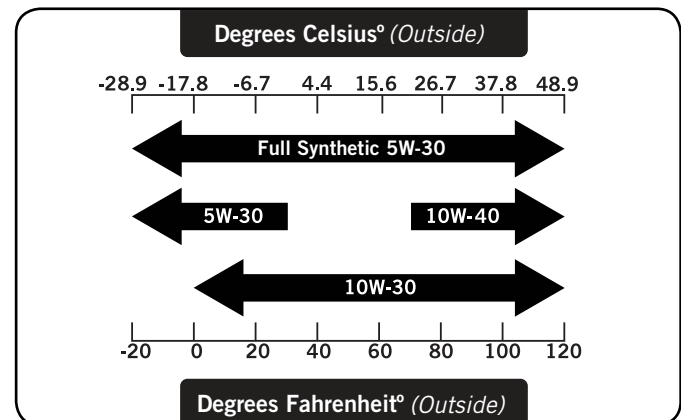

NOTE

Weather will affect engine oil and engine performance. Change the type of engine oil used based on weather conditions to suit the engine needs.

ASSEMBLY

Add Fuel

1. Use clean, fresh, regular unleaded fuel with a minimum octane rating of 85 and an ethanol content of less than 10% by volume.
2. DO NOT mix oil with fuel.
3. Clean the area around the fuel cap.
4. Remove the fuel cap.
5. Slowly add fuel to the tank. DO NOT OVERFILL. Fuel can expand after filling. A minimum of $\frac{1}{4}$ in. (6.4 mm) of space left in the tank is required for fuel expansion, more than $\frac{1}{4}$ in. (6.4 mm) is recommended. Fuel can be forced out of the tank as a result of expansion if it is overfilled, and can affect the stable running condition of the product. When filling the tank, it is recommended to leave enough space for the fuel to expand.

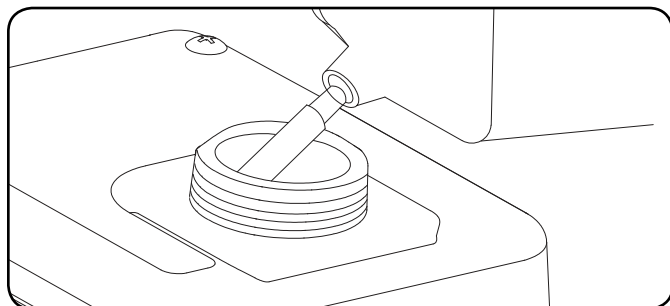

6. Screw on the fuel cap and wipe away any spilled fuel.

WARNING

Pouring fuel too fast through the fuel screen may result in blow back of fuel at the operator while filling.

Add Fuel Cont'd.

CAUTION

Use regular unleaded gasoline with a minimum octane rating of 85.

Do not mix oil and gasoline.

Fill tank to approximately $\frac{1}{4}$ in. (6.4 mm) below the top of the tank to allow for fuel expansion.

DO NOT pump gas directly into the tank at the gas station. Use an approved container to transfer the fuel to the tank.

DO NOT fill fuel tank indoors.

DO NOT fill fuel tank when the engine is running or hot.

DO NOT overfill the fuel tank.

DO NOT light cigarettes or smoke when filling the fuel tank.

NOTE

Our engines work well with 10% or less ethanol blend fuels. When using blended fuels there are some issues worth noting:

- Ethanol-gasoline blends can absorb more water than gasoline alone.
- These blends can eventually separate, leaving water or a watery goo in the tank, fuel valve and carburetor.
- With gravity-fed fuel supplies, this compromised fuel can be drawn into the carburetor and cause damage to the engine and/or potential hazards.
- There are only a few suppliers of fuel stabilizer that are formulated to work with ethanol blend fuels.
- Any damages or hazards caused by using improper fuel, improperly stored fuel, and/or improperly formulated stabilizers, are not covered by manufacture's warranty.

It is advisable to always shut off the fuel supply, run the engine to fuel starvation and drain the tank when the equipment is not in use for more than 30 days.

Starting the Engine

1. Make certain the engine is on a flat, level surface.
2. Flip engine switch to "ON" position (Item A).
3. Rotate the fuel valve to the "ON" position (Item B).
4. Move the throttle lever (Item C) to the "Fast" position.
5. Move the choke lever (Item D) to the "Choke" position.
6. Pull the starter cord slowly until resistance is felt and then pull rapidly. **SEE NOTE BELOW.**

NOTE

Keep choke lever in "Choke" position for 2 pulls of the recoil starter. After first pull, move choke lever to the "Run" position for up to the next 3 pulls of the recoil starter. Too much choke leads to spark plug fouling/engine flooding due to the lack of incoming air. This will cause the engine not to start.

7. As engine warms up, move the choke lever (Item D) to "Run."

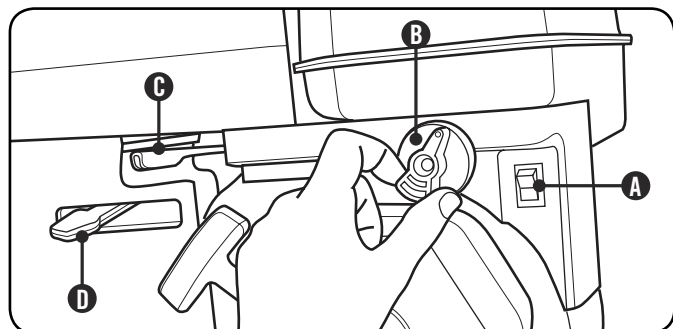

NOTE

If the engine starts but does not run make certain that the engine is on a flat, level surface. The engine is equipped with a low oil sensor that will prevent the engine from running when the oil level falls below a critical threshold.

Stopping the Engine

1. Turn the fuel knob to the "Off" position. (B)
 2. Let the engine run until fuel starvation has stopped the engine. This usually takes a few minutes.
 3. Turn the engine switch to the "Off" position. (A)
- Important:** Always ensure that the Fuel Valve and the Engine Switch are in the "OFF" position when the engine is not in use.

NOTE

If the engine will not be used for a period of two (2) weeks or longer, please see the Storage section for proper engine and fuel storage.

Operation at High Altitude

The density of air at high altitude is lower than at sea level. Engine power is reduced as the air mass and air-fuel ratio decrease. Engine power and output will be reduced approximately 3½% for every 1000 feet of elevation above sea level. This is a natural trend and cannot be changed by adjusting the engine. At high altitudes increased exhaust emissions can also result due to the increased enrichment of the air fuel ratio. Other high altitude issues can include hard starting, increased fuel consumption and spark plug fouling. To alleviate high altitude issues other than the natural power loss, Champion Power Equipment can provide a high altitude carburetor main jet. The alternative main jet and installation instructions can be obtained by contacting Customer Support. Installation instructions are also available in the Technical Bulletin area of the Champion Power Equipment internet site.

The part number and recommended minimum altitude for the application of the high altitude carburetor main jet is listed in the table below.

In order to select the correct high altitude main jet it is necessary to identify the carburetor model. For this purpose, a code is stamped on the side of the carburetor. Select the correct main jet part number corresponding to the carburetor code found on your particular carburetor.

Carburetor Code	Main Jet	Part Number	Altitude
P19-1-Z	Standard	26.131017.00.Z	3500 Feet (1067 Meters)
	Altitude	26.131017.00.01.Z	
P19-1-H	Standard	26.131017.00.H	
	Altitude	26.131017.00.01.H	
P19-1-Y	Standard	26.131017.00.Y	
	Altitude	26.131017.00.01.Y	

WARNING

Operation using the alternative main jet at elevations lower than the recommended minimum altitude can damage the engine. For operation at lower elevations, the standard main jet must be used. Operating the engine with the wrong engine configuration at a given altitude may increase its emissions and decrease fuel efficiency and performance.

MAINTENANCE AND STORAGE

The owner/operator is responsible for all periodic maintenance.

WARNING

Never operate a damaged or defective engine.

WARNING

Improper maintenance will void your warranty.

NOTE

For service or parts assistance, contact our help line at **1-877-338-0999**.

Complete all scheduled maintenance in a timely manner. Correct any issue before operating the engine.

Engine Maintenance

To prevent accidental starting, remove and ground spark plug wire before performing any service.

Oil

Change oil when the engine is warm. Refer to the oil specification to select the proper grade of oil for your operating environment.

1. Remove the oil drain plug with a 12 mm socket and extension (not included).
2. Allow the oil to drain completely.
3. Replace the drain plug.
4. Remove oil fill cap/dipstick to add oil.
5. Using a funnel, add up to 0.6 qt. (0.6 L) of oil and replace oil fill cap/dipstick.
6. Dispose of used oil at an approved waste management facility.

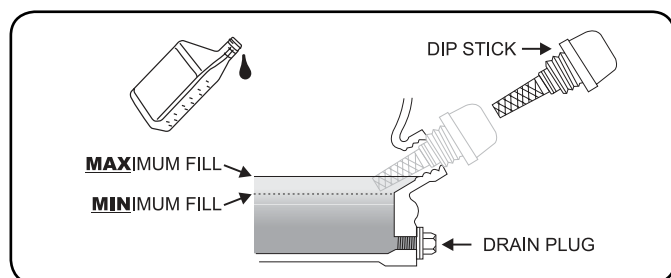

Spark Plugs

1. Remove the spark plug cable from the spark plug.
2. Use a spark plug socket to remove the plug.
3. Inspect the electrode on the plug. It must be clean and not worn to produce the spark required for ignition.
4. Make certain the spark plug gap is 0.7 - 0.8 mm or (0.028 - 0.031 in.).

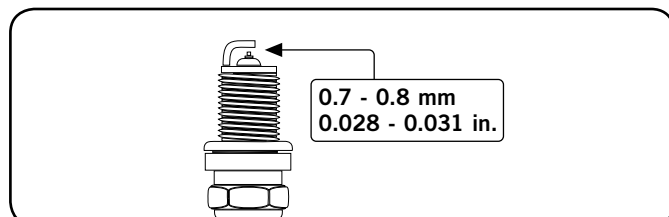

5. Refer to the spark plug recommendation chart when replacing the plug.
6. Carefully thread the plug into the engine.
7. Use a spark plug socket to firmly install the plug.
8. Attach the spark plug wire to the plug.

Air Filter

1. Unscrew wing nut to remove the air filter cover.
2. Remove the supporter and foam element.
3. Tap the foam element to remove dirt and debris. Use compressed air (25 PSI) to clear debris.
4. For the foam element: Wash in liquid detergent and water. Squeeze thoroughly dry in a clean cloth.
5. Saturate in clean engine oil.
6. Squeeze in a clean, absorbent cloth to remove all excess oil.
7. Reassemble the elements and the supporter.
8. Reattach the air filter cover and snap in place.
9. Tighten wing nuts.

Cleaning

Use a damp cloth to clean exterior surfaces of the engine.
Use a soft bristle brush to remove dirt and oil.
Use an air compressor (25 PSI) to clear dirt and debris from the engine.

! CAUTION

DO NOT use a garden hose to clean the engine.

Water can contaminate the fuel system and can enter the engine through the cooling slots and damage the engine.

Maintenance Schedule

Follow the service intervals indicated in the schedule below. Service your engine more frequently when operating in adverse conditions. Contact our help line at **1-877-338-0999** to locate the nearest Champion Power Equipment authorized service dealer for your engine maintenance needs.

Every 8 hours or daily	
	Check oil level
	Clean around air intake and muffler
First 5 hours	
	Change oil
Every 50 hours or every season	
	Clean air filter
	Change oil if operating under heavy load or in hot environments
Every 100 hours or every season	
	Change oil
	Clean/Adjust spark plug
	Check/Adjust valve clearance*
	Clean spark arrester
	Clean fuel tank and filter*
Every 250 hours	
	Clean combustion chamber*
Every 3 years	
	Replace fuel line

*To be performed by knowledgeable, experienced owners or Champion Power Equipment certified dealers.

Storage

Refer to the Maintenance section for proper cleaning instructions.

Engine Stored for Less than 30 Days

1. Allow the engine to cool completely before storage.
2. Clean engine according to the Maintenance section.
3. To extend the fuel storage life add fuel stabilizer.
4. Turn the fuel valve to the off position.

Engines Stored for Over 30 Days

1. Run the engine with the fuel valve in the "Off" position until the engine stops.
2. The engine needs to cool completely before storage.
3. Clean engine according to the Maintenance section.
4. Drain all fuel completely from the fuel line and carburetor to prevent gum from forming.
5. Add a fuel stabilizer into the fuel tank.
6. Change the oil.
7. The fuel valve needs to be in the off position.
8. Remove the spark plug and pour about 1/2 ounce (14.8 ml) of oil into the cylinder. Crank the engine slowly to distribute the oil and lubricate the cylinder.
9. Reattach the spark plug.

! WARNING

Never store the engine inside next to appliances where there is a source of heat or open flame, spark or pilot light because they can ignite gasoline vapors.
DO NOT store an engine near fertilizer or any corrosive material.
Even with an empty gas tank, gasoline vapors could ignite.

⚡ DANGER

Engine exhaust contains odorless and colorless carbon monoxide gas.

To avoid accidental or unintended ignition of your engine during periods of storage, the following precautions should be followed:

- When **storing the engine for short or extended periods of time** make sure that the Engine Switch and the Fuel Valve are set in the **OFF** position.

TROUBLESHOOTING

Problem	Cause	Solution
Engine will not start	No fuel	Add fuel
	Faulty spark plug	Replace spark plug
Engine will not start; Engine starts but runs roughly	Low oil level	Fill crankcase to the proper level Place engine on a flat, level surface
	Choke in the wrong position	Adjust choke
	Spark plug wire loose	Attach wire to spark plug
Engine shuts down during operation	Out of fuel	Fill fuel tank
	Low oil level	Fill crankcase to the proper level. Place generator on a flat, level surface
Engine cannot supply enough power or overheating	Insufficient ventilation	Check for air restriction. Move to a well ventilated area
Engine gallops	Engine governor defective	Contact the help line

For further technical support:

Technical Service

Mon – Fri 8:30 AM – 5:00 PM (PST/PDT)

Toll Free: 1-877-338-0999

tech@championpowerequipment.com

Engine Specifications

- Engine 196 cc OHV CPE
- PTO Rotation Counterclockwise
- Ignition Mode TCI (transistorized)
- Displacement 196 cc
- Torque (max) 8.1 ft-lb at 2800 RPM
- Compression 8.5:1
- Output Shaft 3/4 in. x 2.4 in. (1.9 cm x 6.1 cm)
- End Hole Tapped 5/16 in. 24 UNF
- Fuel Capacity 0.9 gallons (3.4 L)
- Gross Weight 40.3 lb. (18.3 kg)
- Net Weight 35.7 lb. (16.2 kg)
- Height 14.2 in. (36.1 cm)
- Width 14.5 in. (36.8 cm)
- Length 12.1 in. (30.7 cm)

Fuel

Fuel capacity is 0.9 gallons (3.4 L). Use regular unleaded gasoline with a minimum octane rating of 85 and an ethanol content of less than 10% by volume.

Oil

Use 10W-30 automotive oil.
 Oil capacity is 0.6 qt. (0.6 L).
 Please reference the following chart for recommended oil types for use in the engine.

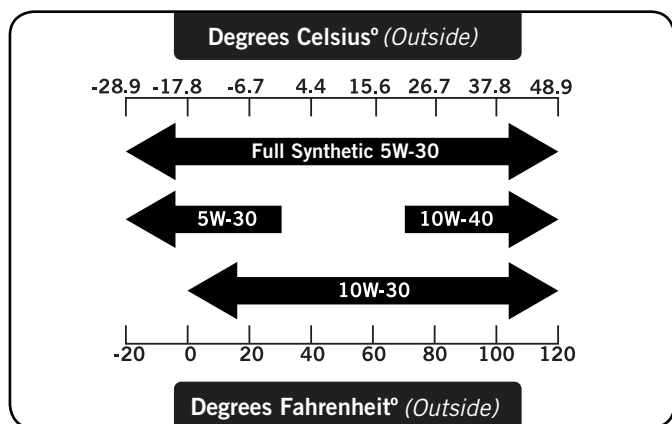

Spark Plugs

OEM spark plug: NHSP F6RTC

Replacement spark plug: NGK BPR6ES or equivalent
 Make certain the spark plug gap is 0.7 - 0.8 mm or (0.028 - 0.031 in.).

Maintenance Valve Clearance

- Intake: 0.13 – 0.17 mm (0.005 – 0.007 in.)
 - Exhaust: 0.18 – 0.22 mm (0.007 – 0.009 in.)
- Note: Tech bulletin regarding the valve adjustment procedure is on www.championpowerequipment.com.

Keyway Shaft

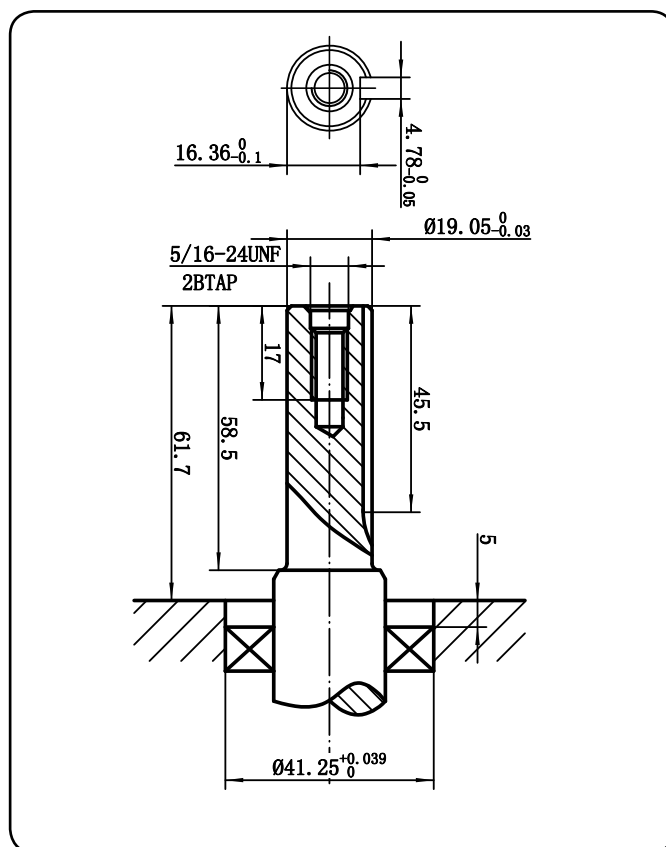

NOTE

Weather will affect engine oil and engine performance. Change the type of engine oil used based on weather conditions to suit the engine needs.

SPECIFICATIONS

Parts Diagram

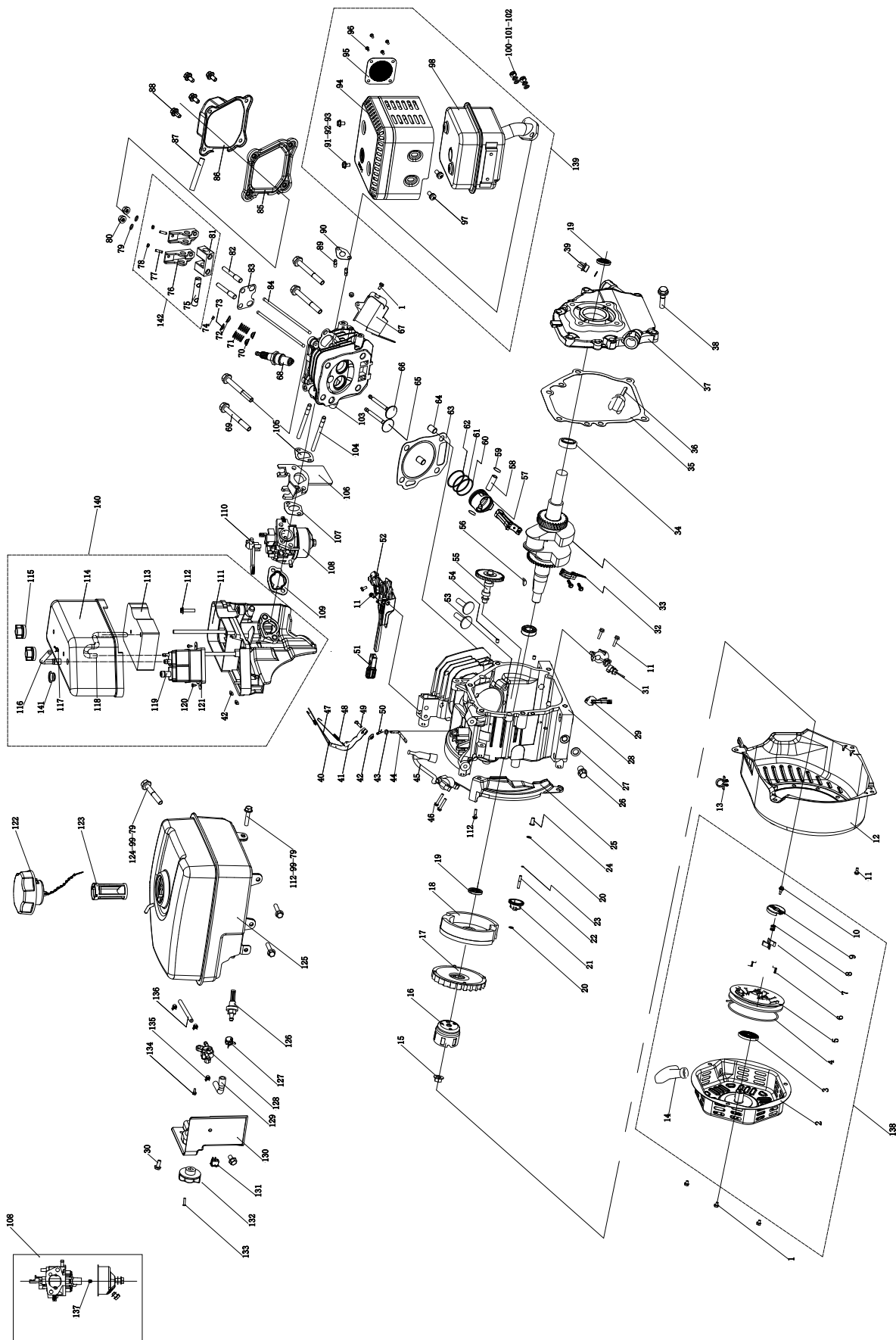

#	Part Number	Description	Qty
1	1.5789.0608	Flange Bolt M6 x 8	5
2	22.061100.00.2	Cover, Recoil Starter, Black	1
3	21.061005.00	Spring, Recoil Starter	1
4	2.10.003.1	Rope Ø4 x 1550, Black	1
5	21.061001.01	Reel, Recoil Starter	1
6	45.060003.00	Spring, Ratchet	2
7	45.060002.00	Starter Ratchet, Steel	2
8	45.060009.00	Spring, Ratchet Guide	1
9	45.060007.00	Ratchet Guide	1
10	45.060008.00	Screw, Ratchet Guide	1
11	1.5789.0612	Flange Bolt M6 x 12	8
12	24.080100.01.48	Fan Cover, Yellow	1
13	2.05.002	Clamp Ø9.5 x 5	1
14	21.061300.00	Handle, Recoil, Soft	1
15	2.02.006	Nut M14 x 1.5	1
16	21.060001.01	Pulley, Starter	1
17	23.080001.00	Cooling Fan	1
18	24.120100.06	Flywheel	1
19	2.11.001	Oil Seal Ø25 x Ø41.3 x 6	2
20	2.03.020.1	Washer Ø6.2 x Ø15 x 0.5, Black	2
21	21.110100.00	Gear, Governor	1
22	21.110013.00	Shaft, Governor Gear	1
23	21.110011.00	Clip, Governor Gear	1
24	21.110012.01	Bushing, Governor Gear, Steel	1
25	23.080600.00	Air Guide, Right	1
26	2.08.037	Drain Bolt M10 x 1.25 x 25	2
27	2.03.016	Washer Ø10 x Ø16 x 1.5, Drain Bolt	2
28	26.030100.00	Crankcase	1
29	21.120400.01	Diode Assembly	1
30	1.5789.0612.3	Flange Bolt M6 x 12	2
31	21.127000.02	Oil Level Sensor	1
32	23.050200.00	Connecting Rod	1
33	25.050100.03	Crankshaft	1
34	1.276.6205	Bearing 6205	2
35	24.030008.00	Gasket, Crankcase Cover	1
36	22.031000.00.48	Oil Dipstick Assembly, Yellow	1
37	24.030007.00	Cover, Crankcase	1
38	1.5789.0832	Flange Bolt M8 x 32	6
39	22.031000.01.48	Oil Filter Cap, Yellow	1
40	23.110005.01	Spring, Throttle Return	1
41	21.110003.00	Arm, Governor	1
42	1.6177.06	Flange Nut M6	3
43	2.03.021.1	Washer Ø6.4 x Ø13 x 1, Black	1
44	21.110001.00	Shaft, Governor Arm	1
45	22.123000.01	Ignition Coil, Silicon Rubber	1
46	1.5789.0625	Flange Bolt M6 x 25	2
47	23.110006.00	Rod, Governor	1
48	23.110007.00	Spring, Governor	1
49	2.08.040	Bolt M6 x 21, Governor Arm	1
50	21.110008.00	Pin, Shaft	1
51	24.111008.01	Grip Sheath, Speed Governor	1
52	24.111000.02	Control Assembly	1
53	25.040013.00	Lifter, Valve	2
54	2.04.001	Dowel Pin Ø9 x 14	2
55	26.041000.01	Camshaft	1
56	2.14.012	Woodruff Key 4 x 7.5 x 19	1
57	26.050005.00	Piston	1
58	23.050003.00	Pin, Piston	1
59	2.09.001	Circlip Ø18 x Ø1	2
60	26.050303.00	Ring, Oil	1
61	26.050302.00	Ring, Second Piston	1
62	26.050301.00	Ring, First Piston	1
63	26.030009.00	Gasket, Cylinder Head	1
64	2.04.003	Dowel Pin Ø10 x 14	2
65	23.040002.00	Valve, Intake	1
66	23.040006.00	Valve, Exhaust	1
67	26.080400.00	Air Guide, Lower	1
68	2.15.002(F6RTC)	Spark Plug F6RTC	1
69	1.5789.0860	Flange Bolt M8 x 60	4
70	23.040017.00	Oil Seal, Valve	2
71	21.040003.00	Spring, Valve	2
72	21.040007.00	Retainer, Exhaust Valve Spring	1

#	Part Number	Description	Qty
73	21.040001.00	Retainer, Intake Valve Spring	1
74	21.040008.00	Rotator, Exhaust Valve	1
75	24.040202.00	Shaft, Rocker Arm	1
76	22.040009.00	Rocker Arm	2
77	22.040012.00	Screw, Valve Adjustment	2
78	21.040021.00	Nut M6 x 0.5, Lock	2
79	1.97.1.06	Washer Ø6	6
80	1.6177.1.06	Flange Nut M6	2
81	24.040201.00	Retainer, Rocker Arm	1
82	23.040010.00	Bolt, Rocker Arm	2
83	24.040004.00	Guide Plate, Push Rod	1
84	23.040005.00	Push Rod	2
85	21.020002.01	Gasket, Cylinder Head Cover	1
86	24.021000.00	Cover, Cylinder Head	1
87	21.020001.00	Breather Tube	1
88	1.5789.0615	Flange Bolt M6 x 15	4
89	2.01.010	Stud Bolt M8 x 35	2
90	26.100001.00	Gasket, Exhaust Pipe	1
91	1.16674.0510	Flange Bolt M5 x 10	2
92	1.848.05	Washer Ø5	2
93	1.93.05	Lock Washer Ø5	2
94	24.101202.00	Muffler Protector	1
95	46.101300.05	Muffler Screen	1
96	1.818.0406	Screw M4 x 6	4
97	1.9074.4.0510	Screw/Washer Assembly M5 x 10	2
98	24.101100.00	Muffler	1
99	1.93.06	Lock Washer Ø6	6
100	1.6175.08	Nut M8	2
101	1.848.08	Washer Ø8	2
102	1.93.08	Lock Washer Ø8	2
103	26.010100.00	Cylinder Head	1
104	2.01.009	Stud Bolt M6 x 110	2
105	24.130002.00	Gasket, Insulator	1
106	23.130001.00	Insulator, Carburetor	1
107	22.130003.00	Gasket, Carburetor	1
108	26.131000.00	Carburetor	1
109	21.130004.00	Gasket, Air Cleaner	1
110	21.130100.00	Choke Handle	1
111	24.091100.01	Base, Air Cleaner	1
112	1.5789.0620	Flange Bolt M6 x 20	5
113	24.091003.02	Element, Air Cleaner	1
114	24.091200.02	Cover, Air Cleaner	1
115	24.091600.01	Screw Cap, Air Clean Cover	2
116	22.070014.00	Pipe, Reversal Valve	1
117	2.06.006	Clamp Ø7 x Ø1	1
118	22.070013.00	Pipe, Air Cleaner	1
119	24.070700.00	Carbon Canister	1
120	1.845.2995	Screw ST2.9 x 9.5	2
121	2.03.037	Washer Ø3.2 x Ø14 x 1	2
122	24.070100.02	Cap, Fuel Tank	1
123	81.070301.00	Fuel Filter, Fuel Tank	1
124	1.5789.0633	Flange Bolt M6 x 33	1
125	24.071000.01	Fuel Tank	1
126	21.070600.03	Joint, Fuel Pipe	1
127	2.06.016	Clamp Ø8.7 x b8	1
128	24.070400.00	Fuel Valve	1
129	24.070011.01	Pipe Ø4.5 x (30 + 30)	1
130	24.070010.00	Veil, Fuel Tank	1
131	5.1010.003.3	Ignition Switch, Red	1
132	24.070001.00	Fuel Knob	1
133	1.818.0412	Bolt M4 x 12	1
134	1.16674.0512.2	Flange Bolt M5 x 12	1
135	2.06.007	Clamp Ø8 x b6	3
136	24.070011.00	Fuel Pipe Ø4.5 x Ø9.5 x 230	1
137	26.131017.00	Main Jet, Standard	1
	26.131017.00.01	Main Jet, Altitude	/
138	22.061000.00	Recoil Assembly	1
139	24.101000.00	Muffler Assembly	1
140	24.091000.02	Air Cleaner Assembly	1
141	2.12.001	Buffer Ø7.5 x 7.5	1
142	24.040200.00	Rocker Arm Assembly	1

WARRANTY

WARRANTY*

CHAMPION POWER EQUIPMENT
2 YEAR LIMITED WARRANTY

Warranty Qualifications

Champion Power Equipment (CPE) will register this warranty upon receipt of your Warranty Registration Card and a copy of your sales receipt from one of CPE's retail locations as proof of purchase. Please submit your warranty registration and your proof of purchase within ten (10) days of the date of purchase.

Repair/Replacement Warranty

CPE warrants to the original purchaser that the mechanical and electrical components will be free of defects in material and workmanship for a period of two years (parts and labor) from the original date of purchase and 180 days (parts and labor) for commercial and industrial use. Transportation charges on product submitted for repair or replacement under this warranty are the sole responsibility of the purchaser. This warranty only applies to the original purchaser and is not transferable.

Do Not Return The Unit To The Place Of Purchase

Contact CPE's Technical Service and CPE will troubleshoot any issue via phone or e-mail. If the problem is not corrected by this method, CPE will, at its option, authorize evaluation, repair or replacement of the defective part or component at a CPE Service Center. CPE will provide you with a case number for warranty service. Please keep it for future reference. Repairs or replacements without prior authorization, or at an unauthorized repair facility, will not be covered by this warranty.

Warranty Exclusions

This warranty does not cover the following repairs and equipment:

Normal Wear

Products with mechanical and electrical components need periodic parts and service to perform well. This warranty does not cover repair when normal use has exhausted the life of a part or the equipment as a whole.

Installation, Use and Maintenance

This warranty will not apply to parts and/or labor if the product is deemed to have been misused, neglected, involved in an accident, abused, loaded beyond the product's limits, modified, installed improperly or connected incorrectly to any electrical component. Normal maintenance is not covered by this warranty and is not required to be performed at a facility or by a person authorized by CPE.

Other Exclusions

This warranty excludes:

- Cosmetic defects such as paint, decals, etc.
- Wear items such as filter elements, o-rings, etc.
- Accessory parts such as starting batteries, and storage covers.
- Failures due to acts of God and other force majeure events beyond the manufacturer's control.
- Problems caused by parts that are not original Champion Power Equipment parts.

When applicable, this warranty does not apply to products used for prime power in place of a utility.

Limits of Implied Warranty and Consequential Damage

Champion Power Equipment disclaims any obligation to cover any loss of time, use of this product, freight, or any incidental or consequential claim by anyone from using this product. THIS WARRANTY AND THE ATTACHED U.S. EPA, CARB and/or ECCC EMISSION CONTROL SYSTEM WARRANTIES (WHEN APPLICABLE) ARE IN LIEU OF ALL OTHER WARRANTIES, EXPRESS OR IMPLIED, INCLUDING WARRANTIES OF MERCHANTABILITY OR FITNESS FOR A PARTICULAR PURPOSE.

A unit provided as an exchange will be subject to the warranty of the original unit. The length of the warranty governing the exchanged unit will remain calculated by reference to the purchase date of the original unit.

This warranty gives you certain legal rights which may change from state to state or province to province. Your state or province may also have other rights you may be entitled to that are not listed within this warranty.

Contact Information

Address

Champion Power Equipment, Inc.
Customer Service
12039 Smith Ave.
Santa Fe Springs, CA 90670 USA
www.championpowerequipment.com

Customer Service

Mon – Fri 8:30 AM – 5:00 PM (PST/PDT)
Toll Free: 1-877-338-0999
info@championpowerequipment.com
Fax no.: 1-562-236-9429

Technical Service

Mon – Fri 8:30 AM – 5:00 PM (PST/PDT)
Toll Free: 1-877-338-0999
tech@championpowerequipment.com
24/7 Tech Support: 1-562-204-1188

*Except as otherwise stipulated in any of the following enclosed Emission Control System Warranties (when applicable) for the Emission Control System: U.S. Environment Protection Agency (EPA), California Air Resources Board (CARB) and/or Environment and Climate Change Canada (ECCC).

**Champion Power Equipment, Inc. (CPE),
The United States Environment Protection Agency (U.S. EPA.) and the California Air Resources Board (CARB)
Emission Control System Warranty**

Your Champion Power Equipment (CPE) engine complies with both the U.S. EPA and state of California Air Resources Board (CARB) emission regulations.

YOUR WARRANTY RIGHTS AND OBLIGATIONS:

The US EPA, California Air Resources Board, and CPE are pleased to explain the Federal and California Emission Control Systems Warranty on your 2018 small off-road engine (SORE) and engine powered equipment. In California, new, small off-road engines (SORE) and new equipment that use small off-road engines (SORE) must be designed, built and equipped to meet the State's stringent anti smog standards. In the other states, new engines and equipment must be designed, built and equipped, at the time of sale, to meet U.S. EPA regulations for small off-road engines (SORE). CPE warrants the emission control system on your small off-road engine (SORE) and equipment for the period of time listed below, provided there has been no abuse, neglect, unapproved modification, or improper maintenance of your equipment.

Your emission control system may include parts such as the carburetor, fuel-injection system, the ignition system, catalytic converter and fuel lines. Also included may be hoses, belts, connectors and other emission related assemblies. Where a warrantable condition exists, CPE will repair your small off-road engine (SORE) at no cost to you including diagnosis, parts and labor. For engines less than or equal to 80cc, only the fuel tank and fuel line is subject to the evaporative emission control warranty requirements of this section.

MANUFACTURER'S EMISSION CONTROL SYSTEM WARRANTY COVERAGE:

This emission control system is warranted for two years, subject to provisions set forth below. If, during the warranty period, emission related part on your engine is defective in materials or workmanship, the part will be repaired or replaced by CPE.

OWNER WARRANTY RESPONSIBILITIES:

As the small off-road engine (SORE) owner, you are responsible for the performance of the required maintenance listed in your Owner's Manual. CPE recommends that you retain all your receipts covering maintenance on your small off-road engine (SORE), but CPE cannot deny warranty solely for the lack of receipts or for your failure to ensure the performance of all scheduled maintenance.

As the small off-road engine (SORE) owner, you should however be aware that CPE may deny you warranty coverage if your small, off-road engine (SORE) or a part has failed due to abuse, neglect, improper maintenance or unapproved modifications.

You are responsible for presenting your small off-road engine to an Authorized CPE service outlet or alternate service outlet as described in (3)(f.) below, CPE dealer or CPE, Santa Fe Springs, Ca. as soon as a problem exists. The warranty repairs should be completed in a reasonable amount of time, not to exceed 30 days.

If you have any questions regarding your warranty rights and responsibilities, you should contact:

Champion Power Equipment, Inc.
Customer Service
12039 Smith Ave.
Santa Fe Springs, CA 90670
1-877-338-0999
tech@championpowerequipment.com

EMISSION CONTROL SYSTEM WARRANTY

The following are specific provisions relative to your Emission Control System (ECS) Warranty Coverage.

1. APPLICABILITY: This warranty shall apply to 1995 and later model year California small off-road engines (SORE) (for other states, 1997 and later model year engines). The ECS Warranty Period shall begin on the date the new engine or equipment is delivered to its original, end-use purchaser, and shall continue for 24 consecutive months thereafter.

2. GENERAL EMISSIONS WARRANTY COVERAGE

CPE warrants to the original, end-use purchaser of the new engine or equipment and to each subsequent purchaser that each of its small off-road engines (SORE) is:

a. Designed, built and equipped so as to conform to U.S. EPA emissions standards for spark-ignited engines at or below 19 kilowatts and all applicable regulations adopted by the California Air Resources Board and

b. Free from defects in materials and workmanship that cause the failure of a warranted part to be identical in all material respects to the part as described in the engine manufacturer's application for certification for a period of two years.

3. THE WARRANTY ON EMISSION-RELATED PARTS WILL BE INTERPRETED AS FOLLOWS:

a. Any warranted part that is not scheduled for replacement as required maintenance in the Owners Manual shall be warranted for the ECS Warranty Period. If any such part fails during the ECS Warranty Period, it shall be repaired or replaced by CPE according to Subsection "d" below. Any such part repaired or replaced under the ECS Warranty shall be warranted for any remainder of the ECS Warranty Period.

b. Any warranted, emissions-related part which is scheduled only for regular inspection as specified in the Owners Manual shall be warranted for the ECS Warranty Period. A statement in such written instructions to the effect of "repair or replace as necessary", shall not reduce the ECS Warranty Period. Any such part repaired or replaced under the ECS Warranty shall be warranted for the remainder of the ECS Warranty Period.

c. Any warranted, emissions-related part which is scheduled for replacement as required maintenance in the Owner's Manual shall be warranted for the period of time prior to the first scheduled replacement point for that part. If the part fails prior to the first scheduled replacement, the part shall be repaired or replaced by CPE according to Subsection "d" below. Any such emissions-related part repaired or replaced under the ECS Warranty, shall be warranted for the remainder of the ECS Warranty Period prior to the first scheduled replacement point for such emissions-related part.

d. Repair or replacement of any warranted, emissions-related part under this ECS Warranty shall be performed at no charge to the owner at a CPE Authorized Service Outlet.

e. The owner shall not be charged for diagnostic labor which leads to the determination that a part covered by the ECS Warranty is in fact defective, provided that such diagnostic work is performed at a CPE Authorized Service Outlet.

f. CPE shall pay for covered emissions warranty repairs at non-authorized service outlets under the following circumstances:

i. The service is required in a population center with a population over 100,000 according to U.S. Census 2000 without a CPE Authorized Service Outlet AND

ii. The service is required more than 100 miles from a CPE Authorized Service Outlet. The 100 mile limitation does not apply in the following states: Alaska, Arizona, Colorado, Hawaii, Idaho, Montana, Nebraska, Nevada, New Mexico, Oregon, Texas, Utah and Wyoming.

g. CPE shall be liable for damages to other original engine components or approved modifications proximately caused by a failure under warranty of an emission-related part covered by the ECS Warranty.

h. Throughout the ECS Warranty Period, CPE shall maintain a supply of warranted emission-related parts sufficient to meet the expected demand for such emission-related parts.

i. Any CPE Authorized and approved emission-related replacement part may be used in the performance of any ECS Warranty maintenance or repair and will be provided without charge to the owner. Such use shall not reduce CPE's warranty obligation.

j. Unapproved add-on or modified parts may not be used to modify or repair a CPE engine. Such use voids this ECS Warranty and shall be sufficient grounds for disallowing an ECS Warranty claim. CPE shall not be liable hereunder for failures of any warranted parts of a CPE engine caused by the use of such an unapproved add-on or modified part.

EMISSION-RELATED PARTS INCLUDE THE FOLLOWING: (using those portions of the list applicable to the engine)

Systems covered by this warranty	Parts Description
Fuel Metering System	Fuel regulator, Carburetor and internal parts
Air Induction System	Air cleaner, Intake manifold
Ignition System	Spark plug and parts, Magneto ignition system
Exhaust System	Exhaust manifold, catalytic converter
Miscellaneous Parts	Tubing, Fittings, Seals, Gaskets, and Clamps associated with these listed systems.
Evaporative Emissions	Fuel Tank, Fuel Cap, Fuel Line, Fuel Line Fittings, Clamps, Pressure Relief Valves, Control Valves, Control Solenoids, Electronic Controls, Vacuum Control Diaphragms, Control Cables, Control Linkages, Purge Valves, Vapor Hoses, Liquid/Vapor Separator, Carbon Canister, Canister Mounting Brackets, Carburetor Purge Port Connector

TO OBTAIN WARRANTY SERVICE:

You must take your CPE engine or the product on which it is installed, along with your warranty registration card or other proof of original purchase date, at your expense, to any Champion Power Equipment dealer who is authorized by Champion Power Equipment, Inc. to sell and service that CPE product during his normal business hours. Alternate service locations defined in Section (3)(f.) above must be approved by CPE prior to service. Claims for repair or adjustment found to be caused solely by defects in material or workmanship will not be denied because the engine was not properly maintained and used.

If you have any questions regarding your warranty rights and responsibilities, or to obtain warranty service, please write or call Customer Service at Champion Power Equipment, Inc.

**Champion Power Equipment, Inc.
12039 Smith Ave.
Santa Fe Springs, CA 90670
1-877-338-0999
Attn.: Customer Service
tech@championpowerequipment.com**