

# CVT 1stereo 1ub/2ub/3ub/uhf - II

## Installation Instructions



The Channel Vision Multi-Room Video CVT Modulator makes it easy to map any three audio/video sources to any unused channels on your television set(s). Watching your security cameras, laser disk, video tape, or any other video signal becomes as easy as switching channels with your remote.

Because the CVT Modulator merges these additional inputs into your existing TV signal "ahead of" your television sets the new channels will be available at every TV hooked up to your coax cable.

You can even map your *stereo* system to an unused TV channel to pipe music to any room on your TV "network!"

22600-A Lambert St., Suite 707 ♦ Lake Forest, CA 92630  
(949) 770-2008 ♦ (800) 840-0288 ♦ (949) 770-2085 fax  
<http://www.channelvision.com> ♦ E-Mail: [sales@channelvision.com](mailto:sales@channelvision.com)

	<b>CAUTION</b> <b>RISK OF ELECTRIC SHOCK</b> <b>DO NOT OPEN</b>	
<b>CAUTION: TO REDUCE THE RISK OF ELECTRIC SHOCK, DO NOT REMOVE COVER. PROPER VENTILATION REQUIRED. NO USER-SERVICEABLE PARTS INSIDE. REFER SERVICING TO QUALIFIED SERVICE PERSONAL.</b>		
<b>Products to be installed by certified dealers only.</b> Certification Requirements: Must be professional installing dealer, pass certification test and familiar with TV and antenna systems. Call 800/840-0288 for Channel Vision Training Manual and certification test.		

## Basic Installation Instructions

The Channel Vision Multi-Room Video CVT Modulator is easy to hook-up. Just connect your video sources to the CVT Modulator as you would connect them directly to your TV's "video in."

Determine what channels you want to map your video sources to, then, with the power off, use the DIP Switch Settings Table to set the dip switches on the back of the CVT to provide that channel selection range.

Confirm that the video sources you're going to hook up are sending good signals. Attach them to the video and audio inputs on the back of the CVT Modulator. Connect the RF output on the CVT Modulator to one input of the supplied combiner and your existing cable/TV/antenna cable to the other. Finally, connect the output of the combiner to your TV network and plug the CVT Modulator in to the wall outlet.

Turn your TV on, then press SELECT on the CVT Modulator to cycle the front display to the A, B, or C input. Then select the channel you wish to set (the light on the front panel shows the currently selected input, and the channel display shows the channel to which that source is currently being sent). Change the channel by holding the SELECT down for two seconds until the A/B/C light on the front panel blinks. This puts the CVT Modulator in channel-change mode.

Press the UP or DOWN buttons on the CVT Modulator to adjust the channel number as desired. When satisfied, press SELECT again to exit channel-change mode (the CVT Modulator will automatically exit channel-change mode after 5 seconds of inactivity). Repeat for your other two input sources (if applicable). Leave a channel free between your selected channels to avoid frequency interference. For example, mapping to channels 32-34-36 is fine, but 32-33-34 is not.

We suggest that you connect a RF distribution amplifier to your cable/antenna signal (see set up diagram on next page) so you can easily balance the signal strength of that signal and the CVT Modulator signal. Extreme differences in signal strength may cause interference.

That's all there is to it. The information on the following pages will help you configure more sophisticated home "networks" but is not necessary for basic setups.

## System Design Considerations

Sophisticated home "networks" involving many TV sets are feasible with the CVT Modulator, but care must be taken to design an optimum TV signal distribution system.

TV sets are designed for signals around 10dBmV. Signals substantially below 10dBmV result in weak, fuzzy, snowy pictures.

Signals above 10dBmV may overdrive older TV sets which don't have modern automatic gain controls (which can handle signals to 40dBmV). An inline attenuator (pad) can be used to reduce these signals, and to balance radically different signal strengths at all your TV's.

Signal strength decreases with coax cable length, and through connectors, splitters, and combiners, so it's important to determine how much cable and what in-line devices you'll be using, and adjust your input signal levels with amplifiers at the front end or in-line on your network to compensate for the line losses. (The charts on the back of these instructions will help you calculate likely losses through coax cable runs and splitters.)

In-line amps are powered through the coax cable and can be used to achieve modest signal strength gains; more powerful, a/c powered amps offer more amplification (and usually adjustable gain and tilt

## CVT 3ub/uhf Basic Setup

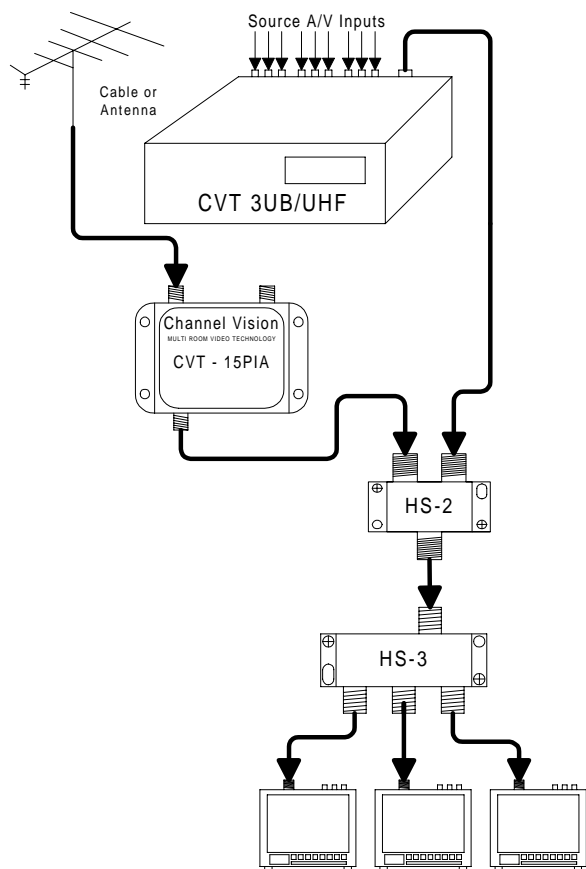

too). Your system should provide 10dBmV to every TV (maximum is 15.5dBmV, per the FCC).

Reverse isolation is used to prevent the signal from your CVT from leaking out to the antenna or cable input. Reverse isolation is accomplished by placing an amplifier between your antenna or cable company input and the CVT combiner. This prevents the CVT signal from propagating back up the input line.

Another way to prevent leakage from your system is to cap all unused coax cable ports on you network with appropriate terminators.

Bandpass filters stop unwanted frequencies while passing all others along. They're handy if a channel you want to use for a CVT source is already in use.

Taps are used to redirect a portion of a signal from the "main" trunk line while passing the remaining signal strength through. For example, a 12dBmV tap would pass 29dBmV from a 30dBmV trunk line signal and pass the remaining 18dBmV to a branch line. (Minor signal loss of 1dB would occur in the trunk line leaving 29dBmV.)

Demodulators are used to demodulate the output of a cable box converter, making it possible to assign the cable signal to any channel (cable boxes usually limit your choices to channel three or channel four). Use a demodulator to "condition" the cable signal before assigning it to a CVT input line.

## Adjustments

**Attenuator:** Decrease signal strength (output dBmV) of modulator.

**Stereo Loop:** Used to pass stereo to TV on non-stereo modulator. 75Ω position is normal, 1KΩ position if using stereo loop.

**Video Level Adjustment:** Adjust the incoming video source base band level.

Use only to increase brightness and balance the channels for consistent contrast. Spectrum analyzer use is suggested.

**Channel Select:** Used to select the input source (A, B or C), you wish to change. Also has a lockout feature to prevent the end user from changing channels. Press and hold for 2 seconds or until front light blinks to allow channel up/down to work.

**Channel Up/Down:** Changes the modulated channel.

**DIP Switch Setting:** Selection of TV frequency band. UHF = Antenna, Ultra = Cable.

## Setting Up TV Channel Range

Example of Dip Switch Settings	
Switch	Band/Channels
<input checked="" type="checkbox"/> <input checked="" type="checkbox"/> <input checked="" type="checkbox"/>	** Cable (59-86 <small>see note below</small> ) **
<input checked="" type="checkbox"/> <input checked="" type="checkbox"/> <input type="checkbox"/>	Cable (65-135)
<input checked="" type="checkbox"/> <input type="checkbox"/> <input type="checkbox"/>	Antenna (14-78)
<input checked="" type="checkbox"/> <input type="checkbox"/> <input checked="" type="checkbox"/>	Antenna (14-39) & Cable (91-135)
<input type="checkbox"/> <input type="checkbox"/> <input type="checkbox"/>	Hi - Z
<input type="checkbox"/> <input type="checkbox"/> <input type="checkbox"/>	75Ω
1 2 3 4	

**\*\*Note:** When using channel range settings 59-86 you must set the dip switches, plug in the unit, set the front display to your desired channel, unplug the power again and then your channels

**Note:** Be sure to remove power from outlet before changing DIP switch settings.

**Note:** Switch positions are relative to back of modulator.

**Note:** Black indicates where the switch should be.

## System Installation Checklist

1. Try for 10dB of signal strength at each television. Use a little more for big screen TV's. Remember, Uncle Sam doesn't like more than 15.5dB of signal going into any TV.
2. When laying out your system, there will be approximately 5dB of signal loss per 100' of RG6.
3. Be sure ALL of your splitters and amplifiers are broadband. Splitters should be 5MHz to 1GHz, and amps should be 40MHz to 1GHz.
4. Check and make sure that all television are set up for the proper frequency spectrum (i.e. UHF or cable).
5. Make sure that the channels you want to modulate on have clean "snow". No lines or interference.

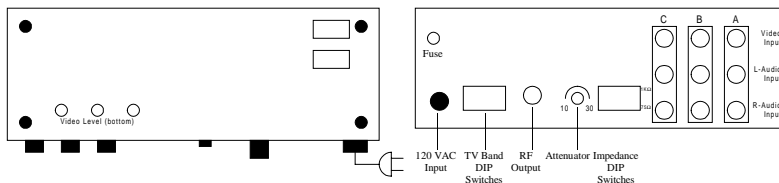

Bottom View

Back View

6. Use a low pass filter on every installation to clean up the frequencies the modulator will be assigned to and keep any potential interference out of the system. Model 3102, cleans up channel 80 and above.
  7. Allow 1 to 2 channel spacing between modulated channels and "active" channels.
  8. Always compensate for insertion loss with splitters and taps. There will always be a drop in antenna/cable signal strength when combining a modulator to an existing system (because of insertion loss with the combiner).
  9. When combining an existing signal with a modulated signal, make sure to have equal signal strength at the point of the combiner so one signal does not degrade the other and cause beat frequencies.
  10. When possible, use the lowest frequencies available for the modulated channels. Lower channels (frequencies) have lower signal loss on the cable runs.
  11. When in doubt, run the signal a little high to the television and use an attenuator to lower the signal strength going into the TV. Attenuators may be combined (i.e. two -3dB attenuators. will equal -6dB).
  12. Make sure to use a well shielded coax of either RG6 Quad or RG11 for RF distribution systems.
  13. Use RG59U Coax for composite/baseband video signals only.
  14. Combine the modulator into the video distribution system as far "up-stream" as possible.
  15. If the system needs to be amplified use the amplifier as far "up-stream" as possible.
2. Check video source (VCR, Sat Receiver etc.) by running the outputs directly into the video inputs on the TV. Verify video source is working.
  3. Check for power at video source.
  4. Disconnect modulator from system:
    - A) Picture goes to snow, problem is between video source and inputs on the modulator.
    - B) Picture stays black, hook up the modulator directly to a TV eliminating all the components of the system and check the picture.

#### **Grainy Local Channels : Good Modulated Picture**

1. Disconnect the modulator from the system and connect the local channel feed directly to the distribution system and check TV picture quality.
  - A) If the picture quality is good the insertion loss of the combiner for the modulator is degrading the local channel signal. Use a CVT-15PIA to compensate for the insertion loss.
  - B) The other alternative is to use a 6dB tap as the combiner, put the local channel feed on the pass through port for a minimal loss of signal connect the modulator to the tap off port.
  - C) If the picture is still bad, check for a bad connection where leakage may occur or if the shielding braid is touching the center conductor.
2. Install model CVT-15PIA amplifier on the incoming cable before the combiner. See basic schematic.

#### **Grainy Modulated Channel : Good Picture on the Cable Channels**

1. Disconnect cable channels from the system and check the modulated channels.
  - A) If the modulated channels are good, use a low pass filter to "clean-up" the incoming frequencies to be modulated.
  - B) If the modulated channel does not improve after disconnecting the local channels, evaluate signal loss of modulator through the splitters and cable length of the system. Amplify after the combiner if needed.
  - C) Also check the connections between modulator and the combiner for leakage or the cable braid is touching the center conductor.
2. Make sure the attenuator adjustment on the back of the modulator is turned to maximum output power.
3. Check output strength with field strength meter.
4. Connect modulator directly to TV and check picture quality.
5. Check bandwidth of all splitters and amplifiers for 1GHz capability.
6. Place TV cable setting on standard, NOT HRC or IRC.

#### **TV Won't Tune High Enough to get Modulated Channel**

1. Use an external tuner i.e. VCR or a Cable Box converter tuner (Channel Vision Model #1172) to allow the TV to view a modulated channel on channel through the external tuner..
2. If the modulated channel is beyond the capabilities for that TV, the TV will not work with the system.

#### **Cable Company Box Won't Pass a Modulated Signal**

1. Connect modulator directly to TV and verify the modulator is sending a signal the TV can receive.
2. Use model 3101 Cable Box Combiner Kit to route the modulated signal around the cable box. See schematic page..

#### **Cable Company Uses All Available Channels**

1. Use a low pass filter (3102) to block out channels 80 and above for clean modulation (won't effect channels 95-99).
2. Call for pricing on a custom filter to block out a specific channel or multiple channels.

#### **Modulated Picture is Too Bright or Washed Out**

## **Trouble Shooting**

Trouble shooting any system can make or break the entire installation.

Here are the most common problems and solutions. After trying these solutions, call 800/840-0288 for 24 hour technical assistance. Calls before 8am and after 5pm pacific standard time will be returned by the technician on call.

#### **Stops Modulating : No Modulation**

Modulator requires proper ventilation for long life reliability and continued operation. Unplug unit, let it cool down, install in well ventilated area to continue operation.

#### **Snowy Picture : No Modulation**

This is a problem of the TV and the modulator not "talking" to each other.

1. Verify the modulator is set up for the proper TV channel band. If cable TV or antenna? If the unit uses dip switches to set the channel band, was the unit powered down during or after the switches were reset to the proper band? If the unit uses a jumper check for proper placement.
2. Verify the TV is set up on the proper TV channel band. Use "Air" for UHF channels or Cable for Ultraband channels . The TV will have an on screen set-up menu or a switch for this function. Also make sure the modulated channel isn't blocked out by auto-programming. To check for the TV being set to the wrong band, go to the equivalent channel on the other band (i.e. to check 65 cable try 14 UHF). Add 51 channels for antenna connection to cable channels.
3. Check TV manual to make sure TV works on channel above 65.
4. Check all connections for a good connection.
5. Check splitters and amplifiers for 1GHz rating.
6. Try another TV, bypass all components and go directly into TV.

#### **Black Picture : No Modulation**

In this case, the TV and the modulator are "talking" to each other. The video signal is not being passed through the system.

1. Verify good connections to the modulator from the video source. i.e. VCR.

1. Slide impedance switch to 75Ω position.
2. If modulator is a CVT set top style, adjust video level adjustment potentiometer on the bottom of the chassis.
3. If using a camera, check positioning of the lens to be sure it's not aimed at the sun or a reflection.
4. Adjust camera lens - see lens manual.

#### Modulated Picture is Too Dark

1. If baseband video is being split with a Stereo Loop Kit or loop through quad, set impedance matching switch (termination switch) to 1KΩ.
2. If modulator is a set top style, adjust video level adjustment potentiometer on the bottom of the chassis.
3. If the video source is not being split, check input source directly into a TV.
4. Adjust the video level adjust pot on the chassis of the set top units to the proper brightness.
5. Check all connectors for 75Ω.

#### Noise on the Audio

1. Insert grounding block in line and ground coax cable before it enters the TV.
2. Use professional grade audio/video interconnect between the components and the modulator.

#### Audio is Too Low

Use a Y-Connector to combine the left and right audio before entering the modulator.

#### Herringbone in Picture on Modulated Channel

Disconnect modulator from local channels and check modulated channel.

- A) If there is programming move the modulated channel.
- B) If the picture is snowy, use a #3102-80 low pass filter to block noise or data coming in from cable company.
- C) Separate modulated channels by two channels.

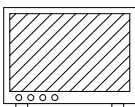

#### Horizontal Bars Rolling Through TV Picture

1. Check for a component of the system to introduce DC power into the system. Disconnect that component and check TV. If the hum bars stop, use a DC blocker down stream from that component to block the power from getting to the TVs.
2. If the rolling is only on the modulated channels, check for impedance mismatch by adjusting the video level adjustment pot.

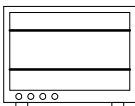

#### Vertical Bars Rolling Through TV Picture

Check for AC power getting on the line. Use a ground breaker in line.

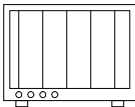

#### Black and White Lines on one Local Channel

Move modulated channel up to a new channel. If problem persists and all of the inputs of a multiple input modulator are not being used, check default channels on modulator to see if default channel is set to the same channel that the problem channel is set to.

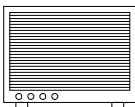

#### Flashing at the Top or Middle of TV Picture

1. If flashing is on modulated channels, turn up attenuator/down gain of modulator.
2. If flashing is on local channels turn down gain or attenuate output of amplifier.

3. Install filter #3102-80 to clean up channels.

#### Picture is Tearing

Possible impedance problem. Check that impedance switch is set to 75Ω.

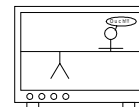

#### Ghosts on the Picture

1. Terminate all unused ports with 75Ω terminator model 2101.
2. Check for low quality combiner in system. Replace with high isolation combiner, HS model combiner.
3. Check the type of coax used in system. Inadequate shielding in coax will cause ghosting. Pull new coax (RG6 quad).

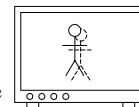

#### Low Channel Pictures are Good, High Channel Picture is Grainy

1. Place a tilt compensator in line after the amplifier and increase amplifier gain until the higher channels look good.
2. Check frequency specifications on all splitters and amplifiers in system. Replace any that are not broadband 5MHz to 1GHz.

#### Low Channels are Wavy Vertical Lines, High Channels are Good

1. Unplug the modulator
  - a) Channels look good : problem is beat frequencies or unbalanced cable vs. modulator.
    1. Decrease modulator power by adjusting attenuator (red knob on back) or use external attenuators before it is combined with the cable TV signal.
    2. Use a 9 or 12dBmV tap in reverse instead of the supplied combiner.
    3. Install a 5 or 10dBmV tilt compensator to reduce low channel power.
    4. Amplify cable TV before you combine modulated signal to balance.
  - b) Low Channels are still bad : bad component in system.
    1. Check signal at source without splitters, amplifiers etc. in the system.
    2. Read system installation checklist.
    3. Trace picture from beginning to end. Use process of elimination.
  - c) Picture still has wavy lines at the source
    1. Call for cable company service. They have a bad component in their system Garbage in equals garbage out.

#### TVs not Receiving all Channels Being Distributed

1. Check coax, if RG59 replace with RG6.
2. Check all splitters and amplifiers for broadband specifications.
3. Check TV specifications for available channels.



# Channel Vision Limited Warranty

Channel Vision Technology will repair or replace any defect in material or workmanship which occur during normal use of this product with new or rebuilt parts, free of charge in the U.S.A., for one year from the date of original purchase. This warranty does not cover damages in shipment, failures caused by other products not supplied by Channel Vision Technology, or failures due to accident, misuse, abuse, or alteration of the equipment. This warranty is extend only to the original purchaser, and a purchase receipt, invoice, or other proof of original purchase date will be required before warranty repairs are provided.

Mail in service can be obtained during the warranty period by calling (800) 840-0288 toll free. A Return Authorization number must be obtained in advance and be marked on the outside of the shipping carton.

This warranty gives you specific legal rights, and you may have other rights (which vary from state to state). If a problem with this product develops during, or after, the warranty period, please contact Channel Vision, your dealer, or any factory-authorized service center.

## CVT 1stereo Specifications

<b>RF Modulator</b>	PLL Synthesized Oscillator
Video	NTSC
Audio	MTS Stereo
<b>RF Carriers</b>	
Frequency Stability	+1KHz
Frequency Ranges	UHF 471.25-855.25MHz Ultraband 433.25-859.25MHz
Channels	UHF 14-78, Ultraband 59-135(Excl 95-99)
Channel Width	6.0MHz
Audio Offset	4.5MHz
Sidebands	Double
<b>RF Output</b>	
Maximum	35dBmV
Gain Range	20dBmV Adjustable Attenuator
Video Output	1VPeak to Peak
Audio Output	1V RMS
<b>Video Performance</b>	
Differential Gain	Less than 2% (0.2dB)
Differential Phase	Less than 3 degree
Signal/Noise Ratio	Greater than 52dB
<b>Spurious Output Rejection</b>	
Outside Carrier	+12MHz Greater than 70dBC
Inside Carrier	+12MHz Greater than 55dBC
Isolation	Greater than 70dBmV
<b>Inputs</b>	
Video	0.4V-2.7V Peak to Peak adjustable
Audio	1V RMS
<b>Connectors</b>	
Video Inputs	RCA Female
Audio Inputs	RCA Female(stereo loop thru)
RF Output	F type female
<b>Signal Combiner</b>	Supplied with unit
<b>Operating Temps</b>	0C to 50C
<b>Transformer Input</b>	
Input Voltage	115 VAC, 50/60Hz
Power	8 Watts
<b>Exterior</b>	ABS resin fiber - black
<b>Display</b>	3 digit channel display
<b>Channel Selector</b>	Up/Down selector buttons
<b>Dimensions:</b>	9" x 6" x 2.8"

Specifications subject to change.

## CVT 1ub/2ub/3ub Specifications

<b>RF Modulator</b>	PLL Synthesized Oscillator
Video	NTSC
Audio	L&R Monaural/Stereo loop opt.
<b>RF Carriers</b>	
Frequency Stability	+1KHz
Frequency Ranges	Antenna/UHF 471.25-855.25MHz Cable/Ultraband 433.25-859.25MHz
Channels	UHF 14-78, Cable 59-135(Excl 95-99)
Channel Width	6.0MHz
Audio Offset	4.5MHz
Sidebands	Double
<b>RF Output</b>	
Maximum	35dBmV
Gain Range	0-20dBmV Adjustable Attenuator
Video Output	1VPeak to Peak
Audio Output	1V RMS
<b>Video Performance</b>	
Differential Gain	Less than 2% (0.2dB)
Differential Phase	Less than 3 degree
Signal/Noise Ratio	Greater than 55dB
<b>Operating Temps</b>	0°C to 50°C
<b>Spurious Output Rejection</b>	
Outside Carrier	+12MHz Greater than 70dBC
Inside Carrier	+12MHz Greater than 55dBC
Isolation	Greater than 70dB
<b>Inputs</b>	
Video	0.4V-2.7V Peak to Peak, adjustable
Audio	1V RMS
<b>Connectors</b>	
Video Inputs	RCA Female
Audio Inputs	RCA Female
RF Output	F type female
<b>Signal Combiner</b>	Supplied with unit
Insertation Loss	3.5dBmV
Bandwidth	5-1000MHz
<b>Transformer Input</b>	
Input Voltage	115 VAC, 50/60Hz
Power	8 Watts
<b>Exterior</b>	ABS resin fiber - black
<b>Display</b>	3 digit channel display
<b>Channel Selector</b>	Up/Down selector buttons
<b>Dimensions:</b>	9" x 6" x 2.8"