

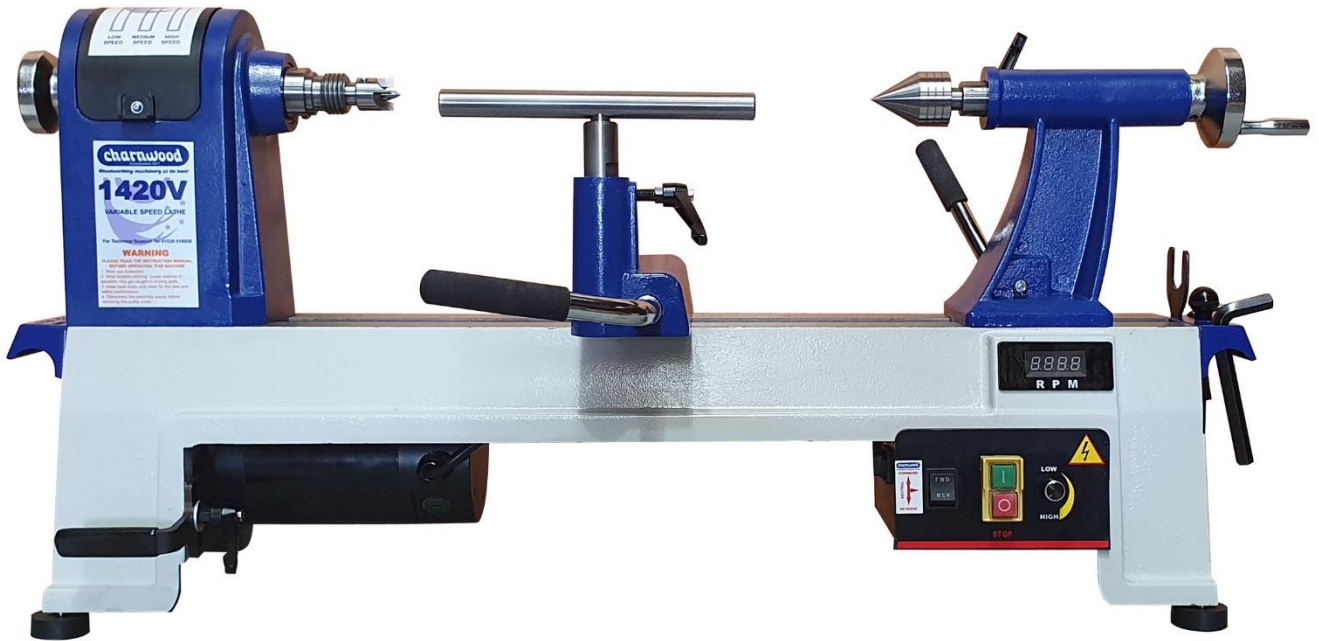

Woodworking machinery at its best!

ELECTRONIC VARIABLE SPEED LATHE OWNERS MANUAL

MODEL: 1420V



Charnwood, Cedar Court, Walker Road,
Hilltop Industrial Estate, Bardon Hill, Leicestershire, LE67 1TU

Tel. 01530 516 926 Fax. 01530 516 929
email: sales@charnwood.net website: www.charnwood.net

GENERAL SAFETY RULES

WARNING: Do not attempt to operate the machine until you have read thoroughly and understood completely all instructions, rules, etc. contained in this manual. Failure to comply may result in accidents involving fire, electric shock, or serious personal injury. Keep this owner's manual and review frequently for continuous safe operation.

1. Know your machine. For your own safety, read the owner's manual carefully. Learn its application and limitations, as well as specific potential hazards pertinent to this machine.
2. Make sure all tools are properly earthed.
3. Keep guards in place and in working order. If a guard must be removed for maintenance or cleaning, make sure it is properly replaced before using the machine again.
4. Remove adjusting keys and spanners. Form a habit of checking to see that the keys and adjusting spanners are removed from the machine before switched it on.
5. Keep your work area clean. Cluttered areas and workbenches increase the chance of an accident.
6. Do not use in dangerous environments. Do not use power tools in damp or wet locations, or expose them to rain. Keep work areas well illuminated.
7. Keep children away. All visitors should be kept a safe distance from the work area.
8. Make workshop childproof. Use padlocks, master switches and remove starter keys.
9. Do not force the machine. It will do the job better and be safer at the rate for which it is designed.
10. Use the right tools. Do not force the machine or attachments to do a job for which they are not designed. Contact the manufacturer or distributor if there is any question about the machine's suitability for a particular job.
11. Wear proper apparel. Avoid loose clothing, gloves, ties, rings, bracelets, and jewellery which could get caught in moving parts. Non-slip footwear is recommended. Wear protective hair covering to contain long hair.
12. Always use safety glasses. Normal spectacles only have impact resistant lenses. They are not safety glasses.
13. Do not over-reach. Keep proper footing and balance at all times.
14. Maintain machine in good condition. Keep machine clean for best and safest performance. Follow instructions for lubrication and changing accessories.
15. Disconnect the machine from power source before servicing and when changing the drive belt.
16. To avoid accidental starting, make sure the switch is in the OFF position before plugging in the mains cable.
17. Never leave the machine running unattended. Turn the power off. Do not leave the machine until it comes to a complete stop.
18. Do not use any power tools while under the effects of drugs, alcohol or medication.
19. Always wear a face or dust mask if operation creates a lot of dust and/or chips. Always operate the tool in a well ventilated area and provide for proper dust removal. Use a suitable dust extractor.

ADDITIONAL RULES FOR LATHES

Never attempt to adjust any part of the workpiece whilst the lathe is still in motion. Wait until the workpiece has come to a complete stop.

1. Ensure that chuck keys, tommy bars and similar items are removed before the lathe is started.
2. Always stand to one side when you start the lathe so that if anything does fly off e.g. a loose piece of bark, you will be out of the line-of-fire.
3. When mounting a new piece of timber, rotate the wood through 360° by hand to ensure that it will not hit the tool rest or the bed of the lathe and then start the lathe at its slowest speed. When you are certain that that the work is secure and not too out of balance set the lathe to the normal turning speed.
4. Always check the rotation speed before switching the lathe on to avoid the risk of starting it whilst it is set to run at too high a speed.
5. The speed of the lathe must be adjusted to suit the size, balance, length and condition of the timber being turned. The greater the diameter of the work, the slower the rotation speed needs to be. If the piece you are turning is out of balance, then you must start turning at a low speed, until it is balanced.
6. The tool must rest firmly on the tool rest before it is brought into contact with the rotating wood and must never be lifted off the tool rest as long as it is in contact with the timber.
7. Before sanding, polishing or doing anything else that brings your fingers close to the work, remove the tool rest. Getting your fingers trapped between the tool rest and the work will at least be very painful and may cause serious injury.
8. Never wrap the sandpaper or polishing cloth round the work. If it tightens up it will pull your fingers into contact with the timber and may lead to serious injury.

Important



Risk of Injury!
Never reach into
Moving parts



Wear Eye
Protection



Wear Ear
Protection

Introduction

In order to get the most out of your lathe, please read through this manual and safety instructions before use. Please keep the manual in case you need it in the future.

Rating Description

Hobby: Suitable for Weekend DIY'ers and woodworking enthusiasts.

Generally lighter weight machines with lower power ratings and smaller tooling capacities. Typically only ever used by one person for short periods of time or longer periods of time infrequently. Machinery should be well maintained in a clean, dry environment such as a home workshop, garage or timber shed.

Expected maximum use of 100 hours annually.

Please Note: Using a product in excess of its rating will void the manufacturer's free warranty.

Technical Data

N.B. The distance between centres will vary and be dependent on the type of centres or accessories used. Maximum distance is 500mm (20").

Max. spindle length (without centres fitted)		500mm (20")
Max. spindle length (with centres fitted)		430mm (17")
Distance over bed		350mm (14")
Motor DC (Carbon Brush)		750w (1hp) 50hz, 240v
Speed Range (Forward & Reverse)	Low	250 - 750rpm
	Medium	600 - 1700rpm
	High	1200 - 3550rpm
Spindle thread size		M33 x 3.5mm
Spindle tapers		MT2
Indexing Positions		24 (every 15 degrees)
Dimensions (WxDxH)		970 x 520 x 300cm
Weight		57kg
Rating		Hobby
Product Guarantee		1 Year

Main Components

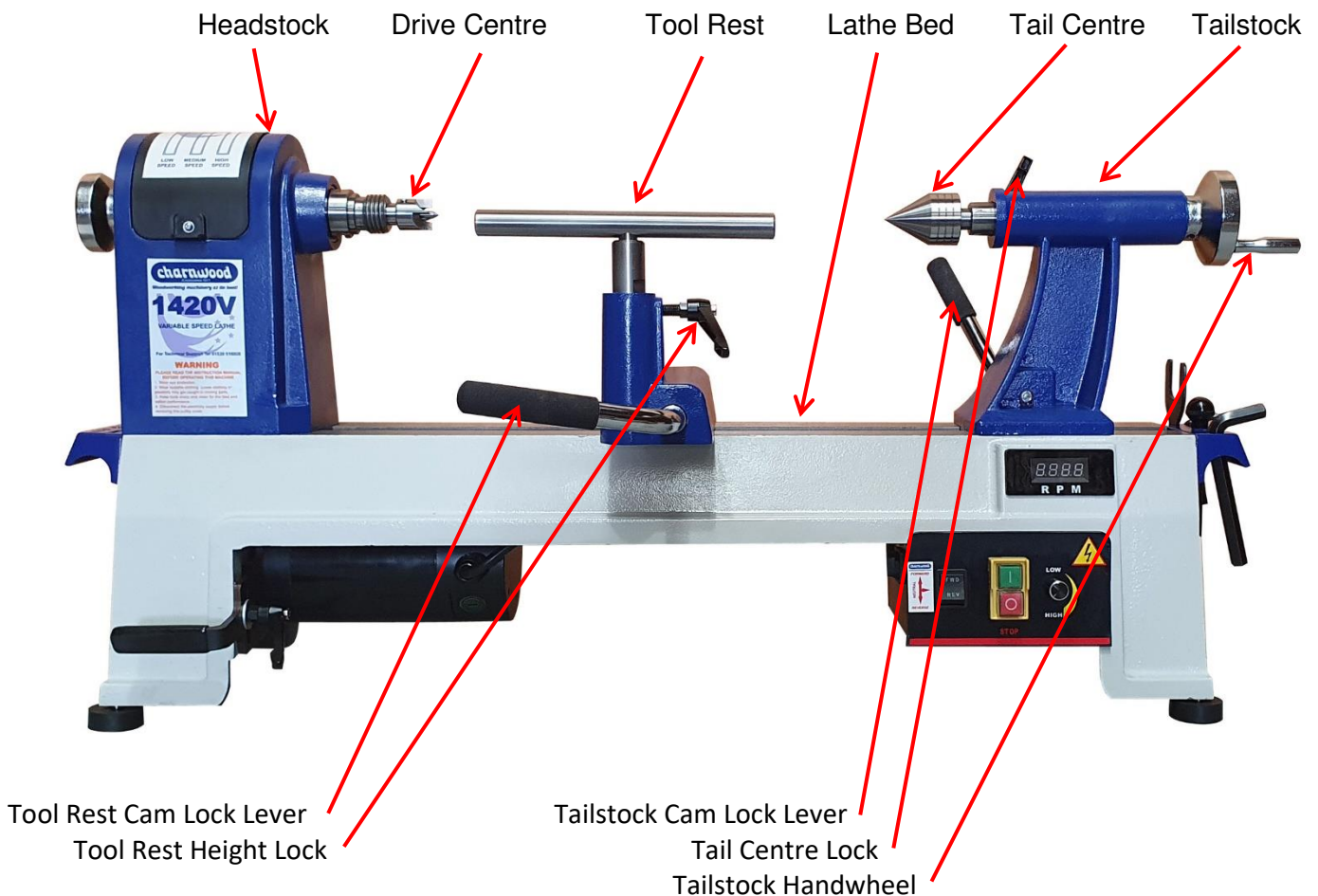

Unpacking



The Lathe is packed in 1 carton.

Do not dispose of the packaging until the lathe has been fully assembled and tested. It will be required in the unlikely event that a return is required.

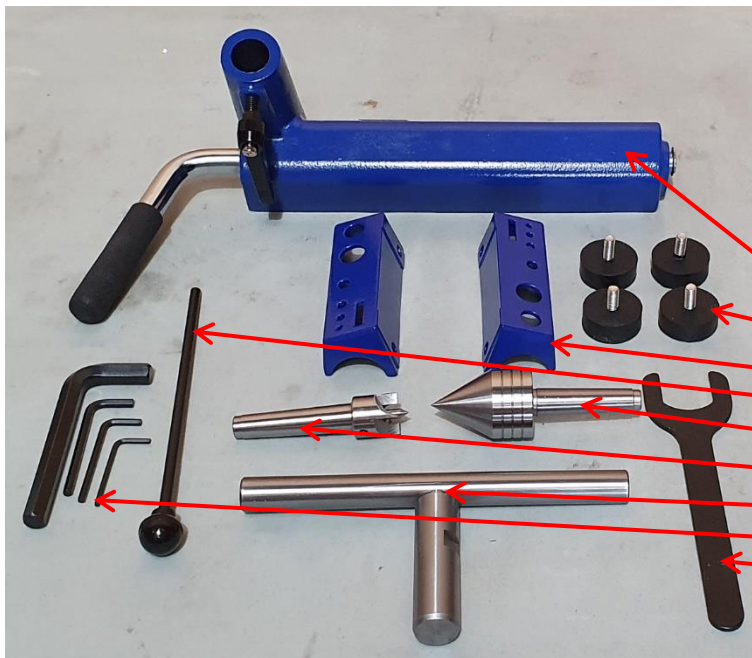

This part of the assembly requires 2 people:
Unpack the carton and remove the contents.

Check the loose items are all present. If anything is missing, please contact us.

- Tool Rest Banjo
- Rubber Foot
- Carry Handle
- Knockout Bar
- Tail Centre
- Drive Centre
- Tool Rest
- Service Tools
- Spindle Spanner

Decide where you wish to mount your lathe. Ideally, the height of the spindle should be approximately level with your elbow when standing/sitting in a working position.

The lathe is sufficiently heavy and stable to be used without fixing to a base provided the workpiece is not too large and the blank well balanced. For larger diameter blanks (6" plus) and unbalanced pieces, it is recommended that the lathe is fixed to a suitable stand or bench.

In that case, do not install the rubber feet and mount directly using the threaded holes.

Assembly



Fit the feet

If you decide to bench mount your lathe, without permanently fixing it, you should now fit the four rubber feet into the four threaded holes in the underside.



Assemble The Tool rest

Rotate the Tailstock Cam Lock Lever, then slide the complete tailstock off the right end of the Bed.

Line up the Tool Rest Banjo and rotate the Tool Rest Cam Lock Lever so that the Clamping Plate is in its lowest position. Slide the Tool Rest Banjo onto the bed.

Fit the Tool Rest into the banjo and lock in place with the Tool Rest Height Lock ratchet handle.

Refit the Tailstock.



Fit the Carry Handles

Use a 5mm Hex key to remove 2 bolts from the end of the bed. Fit the handle and re-tighten the 2 bolts.



The Carry Handles Double as onboard storage for the accessories and service tools.

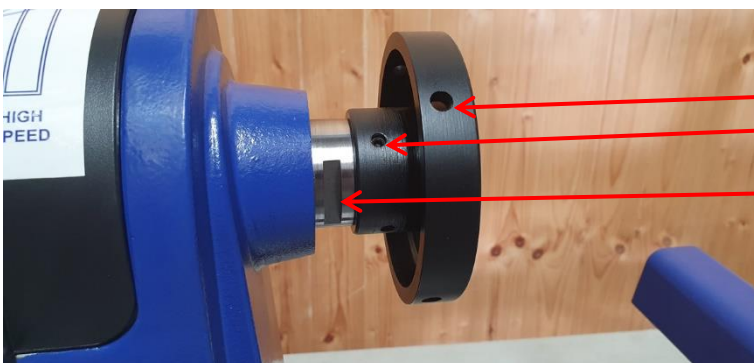

Remove the faceplate

Insert the Knockout Bar through the hole
Use a hex key to undo the 2 grub screws.
Fit the Spindle Spanner over the flats

Unscrew the Face Plate

The faceplate supplied with the lathe has two locking grub screws. It is very important to engage these when running the lathe in reverse direction.

Adjusting the Spindle Speed

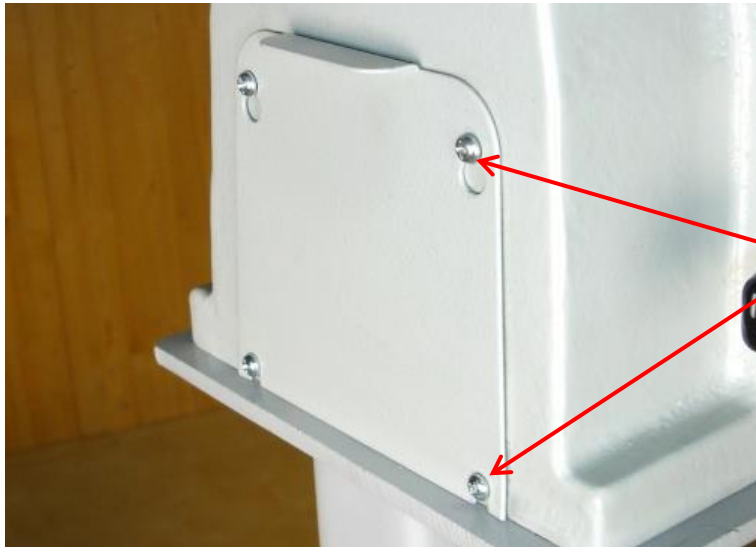

The lathe has electronic variable speed control. There are three ranges of speeds which are obtained by changing the position of the drive belt.

To adjust the drive belt position:

1) Remove the bottom pulley access door by loosening the 4 bolts with a 3mm Hex key. Then raise and lift off the access door.



The **approximate** speed ranges are:

Left Hand Pulleys: 250 - 750rpm

Centre Pulleys: 600 - 1700rpm

Right Hand Pulleys: 1200 - 3550rpm



Remove the retaining screw

Open the upper belt cover

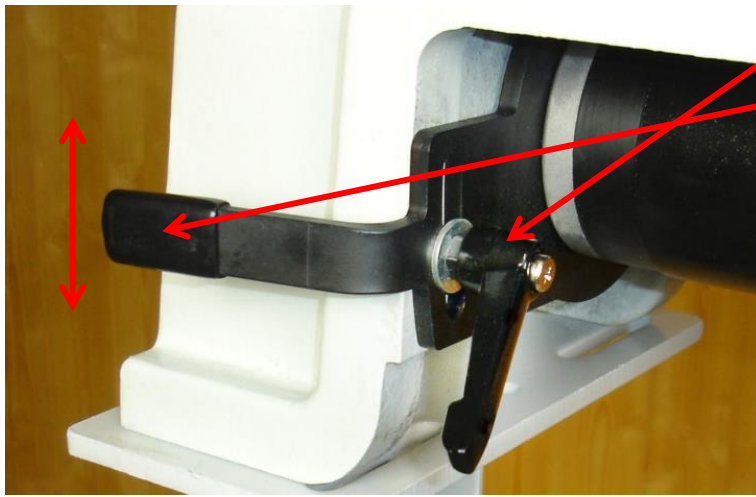

Loosen the Belt Tension Locking handle.
Lift the Belt Tension Lever and tighten the locking handle.

Move the slack belt to the alternate set of pulleys. Always remove the belt from the larger pulley first.

Release the locking lever, apply light pressure to tension the belt and then re-tighten the locking handle.

Close the belt cover and re-fit the pulley door.

After switching on the lathe, adjust the speed using the variable speed control dial.



Forward/Reverse Switch

Variable Speed Control

On/Off Switch



The actual spindle speed will be displayed on the Digital Read Out.

Recommended Turning Speeds

Workpiece Diameter mm	Roughing Cuts RPM	General Cutting RPM	Finishing Cuts RPM
Under 50	1500	3200	3200
50-100	750	1600	2500
100-150	500	1000	1700
150-200	500	800	1250
200-250	500	650	1000
250-300	500	530	850

Forward / Reverse Direction

The Forward / Reverse switch should never be used when the lathe spindle is still rotating. Always stop the lathe by using the OFF switch and wait for the workpiece to come to a standstill before switching direction.



IMPORTANT

When turning a bowl: The lathe should only be used in reverse direction if the accessory mounted to the headstock spindle is locked onto the spindle with grub screws.

Some chucks are not equipped with any form of locking and should never be used in reverse.

The faceplate supplied with the lathe has two thread-locking grub screws.

Using the Lathe

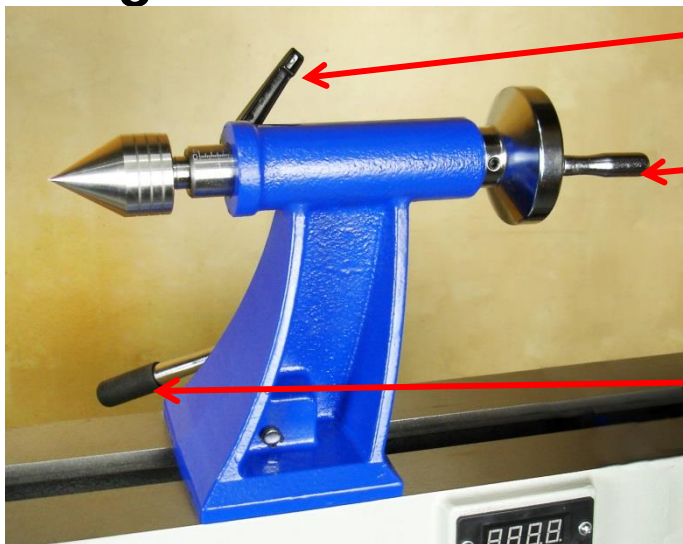

Fine adjustment of the tail centre is made by undoing the Tail Centre Lock (by half a turn only).

Then turn the Tailstock Handwheel to enable the tail centre to be advanced or retracted. It has a travel of 70mm. When fully retracted the Tail Centre will be automatically ejected.

To slide the tailstock along the bed, rotate the Tailstock Cam Lock Lever.

When the tailstock is positioned where required, clamp it firmly in place by rotating the lever back to the locked position.

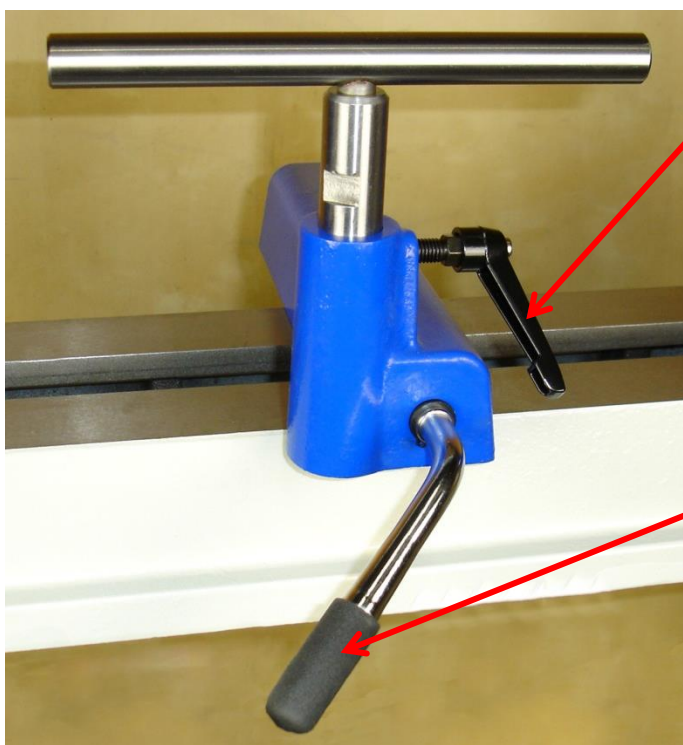

The height of the Tool Rest can also be adjusted, using the Tool Rest Height Lock.

This type of lever can be rotated to a more convenient position, without moving the thread, by pulling the lever away from the thread to disengage the ratchet teeth and then rotating it.

The Tool Rest banjo can be slid along the bed of the lathe.

To release the tool rest banjo rotate the Tool Rest Cam Lock Lever.

The tool rest can now freely slide along the bed. When it is positioned where required, clamp it firmly in place by rotating the lever back to the locked position.

Using the Indexing System

The lathe is fitted with an indexing system which allows the spindle to be locked in any of 24 positions in a full 360 degree rotation, therefore in 15 degree intervals.
The indexing facility is useful for fluted columns, clock faces and accurate hole placements.

	<p>Index Pin Disengaged</p>
	<p>Index Pin Engaged</p>
	<p>Open the top belt pulley cover to expose the indexing ring.</p> <p>Mark a convenient position on the headstock casting and turn the faceplate to line up indexing position 1 with the mark.</p> <p>Then pull out and rotate the indexing pin, until it springs forward and locks the spindle.</p> <p>To move onto the next position, pull out the indexing pin, rotate the spindle by hand until the next number required is lined up with the mark, release the indexing pin to engage the lock.</p>

IMPORTANT: The indexing pin should never be used as a spindle lock

To remove accessories from the spindle, always use the spanner provided to hold the spindle.
Failure to do so, may result in damage to the pin and indexing wheel.

Routine Maintenance

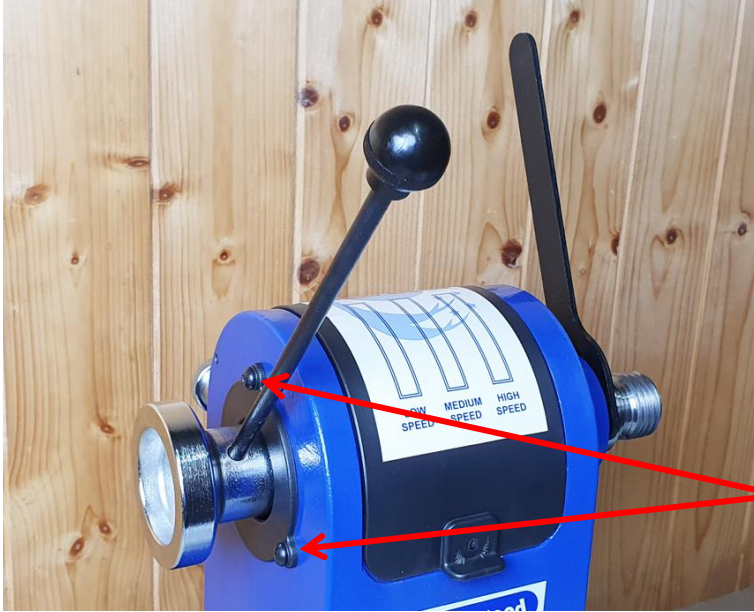

Replacing the Drive Belt

Eventually, the drive belt will become worn and require replacement.

- 1) Use a 3mm Hex key to remove the bottom pulley access door.
- 2) Remove the chrome hand wheel from the spindle by unscrewing it from the spindle. Hold the spindle with the spanner and unscrew the handwheel anticlockwise using the knock-out bar as a lever.
- 3) Use a 3mm Hex key to undo 2 of the 3 bolts to swing the cover plate away to allow access to the drive belt.

4) Open the top belt pulley access cover

5) Release the tension on the drive belt.

6) Remove the old belt by feeding it out of the pulley access port.

7) Fit the new belt by following the instructions in reverse.

Ensure that the V- grooves are on the inside of the belt and correctly seated into the grooves on the pulleys.

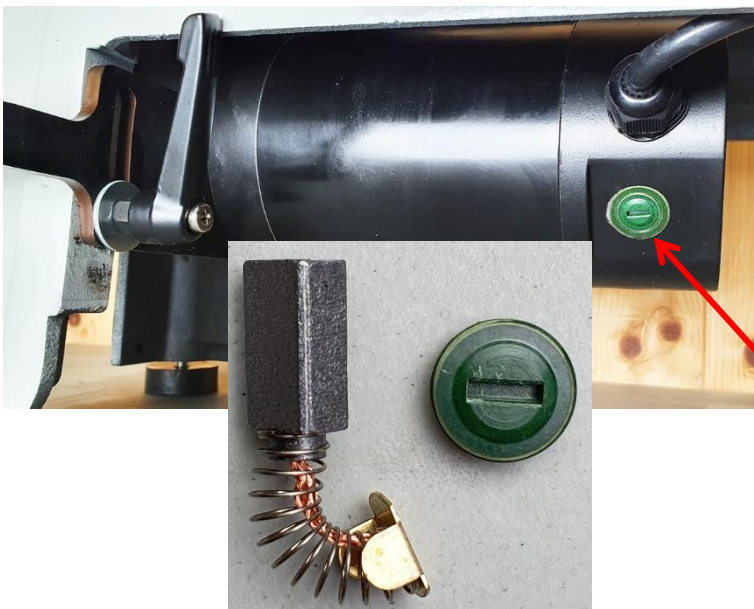

Replacing the Motor Brushes

The carbon brushes should be regularly inspected and will need changing after approximately 500 hours use, or when the block has worn down to a length of 7mm.

1) Remove the motor from the machine by removing the tension adjusting lever and the pivot bolt on the rear side.

Unscrew the two brush covers found on either side of the motor.

Withdraw the worn brush and spring, then replace it with a new one.

Always replace both brushes at the same time.

CHARNWOOD 1420V LATHE TROUBLESHOOTING GUIDE

Fault	Possible Cause	Remedy
Machine will not start	Power supply not connected Fuse in plug blown Fuse in Control Box blown Break in power supply cable Loose terminal on switch Switch failed	Check plug connections in rear of control unit Replace fuse Replace Fuse Visually check cable - replace if necessary Remove switch and check connections Replace switch
Machine will not start, Speed Display Lit	Indexing Pin Engaged Fuse in Control Box blown Speed controller failed Carbon brushes worn	Disengage Indexing Pin Replace fuse Replace speed controller Replace carbon brushes
Machine starts only when green button held	Switch has failed	Replace Switch
Machine starts to turn but slow speed only	Failed variable speed circuit	Check connection to speed dial
Spindle stalls but motor still running	Loose drive belt	Increase belt tension
Motor is running but spindle not turning	Broken drive belt	Replace drive belt
Motor is overheating	Too much load on motor Airflow around motor restricted	Reduce load - make shallower cuts Keep motor clear of shavings
Spindle rotation slows during cut	Excessive depth of cut Chisels are dull Worn carbon brushes Loose drive belt	Make shallower cuts Sharpen chisels Replace brushes Increase belt tension

Charnwood 1420V Wiring Diagram

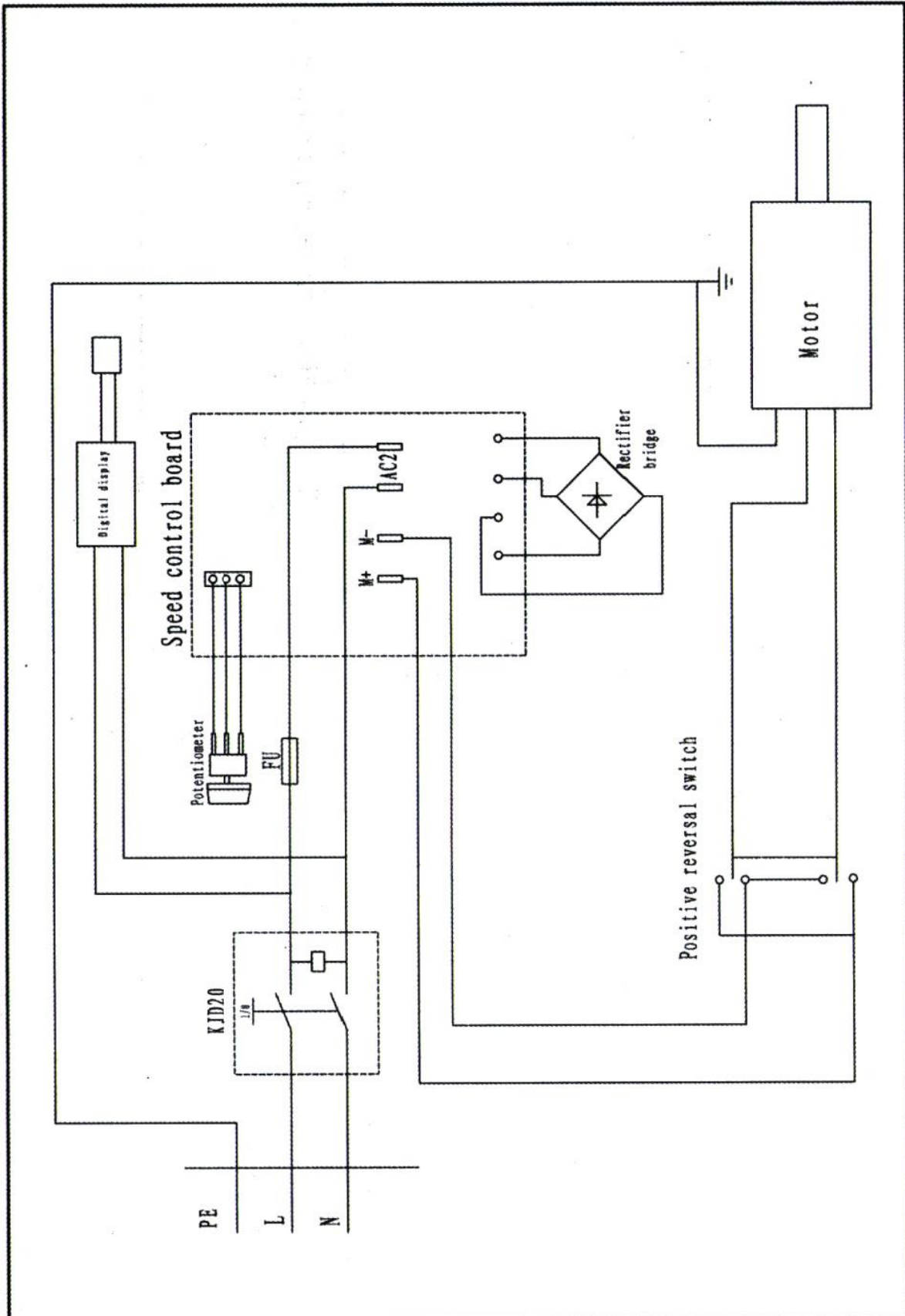

Declaration of Conformity

Charnwood Declare that Woodworking Lathe, Model 1420V

Conforms with the following Directives: Machinery Directive 2006/42/EC
EMC Directive 2014/30/EU

Conforms with the following UK Regulations: Supply of Machinery (Safety) Regulations 2008
Electrical Equipment (Safety) Regulations 2016

And further conforms to the machinery example for which the EC type examination Certificate No. AM 50387407 which has been issued by TUV Rheinland LGA Products GmbH, Tillystrasse 2, 90431, Nurnberg, Germany.

I hereby declare that equipment named above has been tested and found to comply with the relevant sections of the above referenced specifications. The machinery complies with all essential requirements of the directives and regulations.

Signed: 

Dated: 08/02/2022

Location: Leicestershire

Richard Cook
Director



Please dispose of packaging for the product in a responsible manner. It is suitable for recycling. Help to protect the environment, take the packaging to the local amenity tip and place into the appropriate recycling bin.



Only for EU countries
Do not dispose of electric tools together with household waste material!

In observance of European Directive 2002/96/EC on waste electrical and electronic equipment (EEE) and its implementation in accordance with national law, electric tools that have reached the end of their life must be collected separately and returned to an environmentally compatible recycling facility.

Your local refuse amenity will have a separate collection area for EEE goods



Charnwood 1420V Parts List

Part No	Description	Part No	Description
01	Rubber Foot	02	D.C. Motor
03	Belt Tension Lock Lever	04	Flat Washer
05	Motor Plate	06	Cap Head Screw
08	Grub Screw	09	Cap Head Screw
10	Bed	11	Belt Door
12	Cross Head Screw	13	Screw
14	Cap Head Screw	15	Flat Washer
16	Carry Handle	17	Cap Head Screw
18	Spring Washer	19	Headstock
20	Digital Readout Sensor	21	Location Pin Assembly
22	Spindle Pulley	23	Drive Belt 310J
24	Headstock Wheel	25	Locking Nut
26	Knockout Rod Assembly	27	Cover For Motor Pulley
28	Cap Head Screw	29	Grub Screw
30	Bearing	31	Circlip
32	Bearing 6005	33	Spindle
34	Cap Head Screw	35	Face Plate
36	Drive Centre	37	Revolving Tail Centre
38	Sleeve	39	Tailstock
40	Quill Lock Lever	41	Pin
42	Leadscrew	43	Tailstock Handwheel
44	Handwheel Axle	45	Washer
46	Handwheel Handle	47	Grub Screw
48	Tailstock Cam Lock Lever	49	Grub Screw
50	Tailstock Clamp Bolt	51	Clamping Plate
52	Nut	53	Circlip
54	Cross Head Screw	55	Cable Hook
56A	Tool Rest Stem 25mm Dia.	56B	Tool Rest Crossbar
57	Circlip	58	Tool Rest Banjo
59	Tool Rest Height Lock	60	Tool Rest Clamp Bolt
61	Tube	62	Tool Rest Cam Lock Lever
71	Cross Head Screw	75	RPM Digital Readout
77	Spanner	78	Allen Key 3mm
79	Allen Key 4mm	80	Allen Key 5mm
81	Allen Key 12mm	82	Knob
83	Motor Pulley	84	Motor
85	Power Lead	86	Circuit Board
87	Connector for Motor Plug	88	Connector for Power Lead
89	Electrical Box	90	Rubber Grommet
91	Speed Controller	92	Variable Speed Knob
93	Box Cover	94	Switch - KJD20
95	Cross Head Screw	96	Cross Head Screw
97	FWD/REV Toggle Switch	BRUSH	Carbon Brushes x2
VS	Control Unit Complete Parts # 86-94 + 96		

Charnwood 1420V Parts Drawing

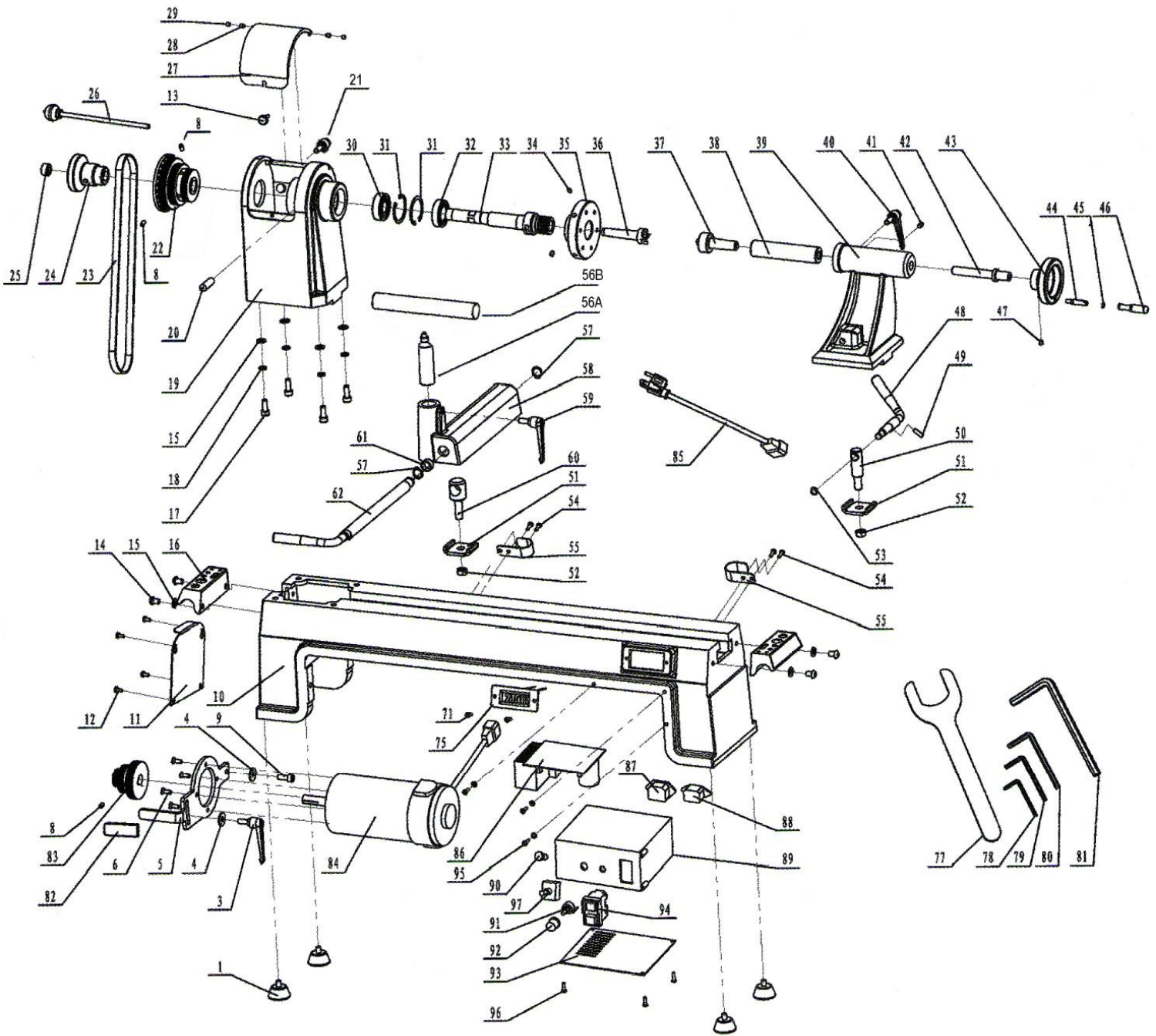

Woodworking machinery at its best!

Updated: March 2022

Charnwood, Cedar Court, Walker Road,
Hilltop Industrial Estate, Bardon Hill, Leicestershire, LE67 1TU

Tel. 01530 516 926 Fax. 01530 516 929
email: sales@charnwood.net website: www.charnwood.net