

CHEFMAN BOILS FASTER™*

FAST-BOIL 1.8L ELECTRIC KETTLE

USER GUIDE

- Safety Instructions
- Features
- Operating Instructions
- Cleaning and Maintenance
- Notes
- Terms and Conditions
- Warranty Registration

RJ11-18-PL

*Boils faster than traditional heating methods like stovetop and microwave.

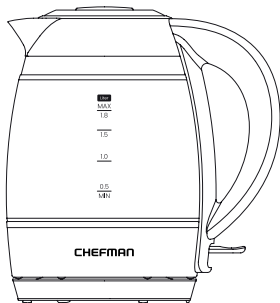

COOKING FORWARD™

Welcome!

Whether this is your first Chefman® appliance or you're already a part of our family, we're happy to be in the kitchen with you. The Fast-Boil 1.8-Liter Electric Kettle is designed to quickly bring a pot of water to a boil for tea or other hot beverages. The rapid-boil technology means you'll have hot water in mere minutes, and with its one-touch operation, it's also super simple to use. Plus, the sleek glass kettle has a blue LED light that runs along the bottom, making it easy to see at a glance when your water is heating and when it's ready for use.

We know you're excited to start sipping, but please take a few minutes to read our directions, safety instructions, and warranty information.

From our kitchen to yours,

The Chefman® Team



READ ALL INSTRUCTIONS BEFORE USE

For your safety and continued enjoyment of this product, always read the instruction manual before using.

CONTENTS

- 4** Safety Instructions
- 8** Features
- 10** Operating Instructions
- 13** Cleaning and Maintenance
- 14** Notes
- 16** Terms and Conditions
- 18** Warranty Registration

SAFETY INSTRUCTIONS

IMPORTANT SAFEGUARDS

When using electrical appliances, basic safety precautions should always be followed, including the following:

1. Read all instructions.
2. Do not touch hot surfaces. Use handle.
3. To protect against electric shock and injuries to persons do not immerse cord, plugs, or unit in water or other liquid.
4. Close supervision is necessary when any appliance is used by or near children.
5. Unplug from outlet when not in use and before cleaning. Allow to cool before putting on or taking off parts, and before cleaning the appliance.
6. Do not operate any appliance with a damaged cord or plug or after the appliance malfunctions, or has been damaged in any manner. If this should occur, contact Chefman® Customer Support for examination, repair, or adjustment.

SAFETY INSTRUCTIONS

IMPORTANT SAFEGUARDS

7. The use of accessory attachments not recommended by Chefman® may result in fire, electric shock, or injury to persons.
8. Do not use outdoors.
9. Do not let cord hang over edge of table or counter, or touch hot surfaces.
10. Do not place on or near a hot gas or electric burner, or in a heated oven.
11. To disconnect, turn any control to OFF, then remove plug from wall outlet.
12. Do not use appliance for other than intended use.
13. Scalding may occur if the lid is opened during the heating cycle.
14. Ensure lid is securely closed before serving any beverages.

FOR HOUSEHOLD USE ONLY
SAVE THESE INSTRUCTIONS

SAFETY INSTRUCTIONS

IMPORTANT SAFEGUARDS

WARNING: This appliance has a polarized plug (one blade is wider than the other). To reduce the risk of electric shock, this plug will fit in a polarized outlet only one way. If the plug does not fit the outlet perfectly, reverse the plug. If it should still not fit, contact a qualified electrician. Do not modify the plug in any way.

SHORT CORD INSTRUCTIONS

A short power-supply cord is provided to reduce the hazards of entanglement or tripping over a longer cord. Longer detachable power-supply cords or extension cords are available and may be used if care is exercised in their use. If a longer detachable power-supply extension cord is used:

1. The marked electrical rating of the extension cord should be at least as great as the electrical rating of the appliance.
2. The longer cord should be arranged so that it will not drape over the countertop or tabletop where it can be pulled on by children or tripped over.

SAFETY INSTRUCTIONS

IMPORTANT SAFEGUARDS

POWER CORD SAFETY TIPS

1. Never pull or yank on the cord or the appliance.
2. To insert the plug, grasp it firmly and guide it into the outlet.
3. To disconnect the appliance, grasp the plug and remove it from the outlet.
4. Never use the product if the power cord shows signs of abrasion or excessive wear. Contact Chefman® Customer Support for additional guidance and support.
5. Never wrap the cord tightly around the appliance, as this could place undue stress on the cord where it enters the appliance and cause it to fray and break.

DO NOT OPERATE THE APPLIANCE IF THE POWER CORD SHOWS ANY DAMAGE OR IF THE APPLIANCE WORKS INTERMITTENTLY OR STOPS WORKING ENTIRELY.

California Proposition 65:
(Applicable for California Residents only)



WARNING:

Cancer and Reproductive Harm -
www.P65Warnings.ca.gov.



Do not place the appliance on a stovetop or any other heatable surface, even if the stovetop is not on. Doing so is a fire hazard.

FEATURES

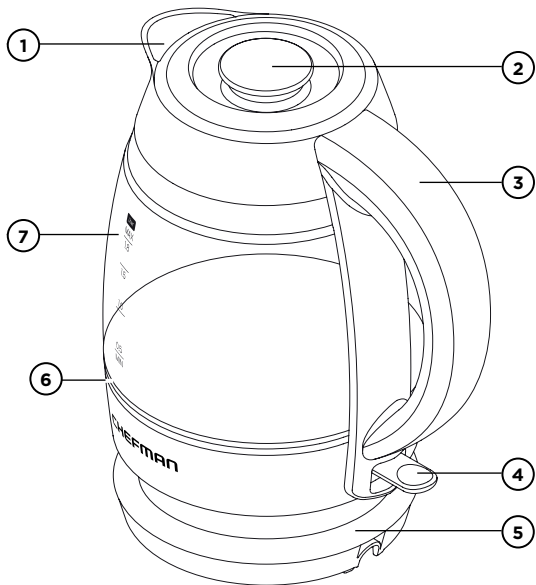

FEATURES

1. Drip-Free Spout (with filter)
2. Removable Lid
3. Stay-Cool Handle
4. Power Switch
5. 360° Swivel Power Base
6. Blue LED Indicator Lights
7. Borosilicate Glass Kettle (with water-level markings)

OPERATING INSTRUCTIONS

BEFORE FIRST USE

1. Remove all packing materials and stickers from the kettle except for the rating label, which should remain on the unit. Be sure that all parts are included before discarding any packaging.
2. Gently wipe down the exterior of the kettle with a damp cloth or paper towel.
3. Unwind the power cord and place the base on a flat surface. (Make sure the power cord comes out of the opening in the base so the unit can sit level.)
4. To rinse the pot of any manufacturing residue, boil and discard a pot of water, following the instructions on p. 11.
5. Once complete, rinse the kettle with fresh water. It is now ready to use.

OPERATING INSTRUCTIONS

HOW TO BOIL WATER

The electric kettle is perfect for all your hot water needs: tea, instant or pour-over coffee, instant oatmeal or soup, and more. The kettle lifts easily off its base for convenient filling at the sink and cord-free serving; it can also be returned to the base from any direction, so it works well for both right- and left-handed users.

1. **Place the base on a flat surface.**
2. **Remove the lid.**
3. **Fill the kettle** to at least the MIN line (0.5 liters) but not above the MAX line (1.8 liters) with cold, fresh water (preferably filtered or bottled). Place the kettle securely onto its base and return the lid to the pot.
4. **Plug in the unit.** Turn the kettle on by pressing down the power switch. The blue LED lights around the base of the kettle will illuminate to indicate the water is heating. **NOTE:** You can cancel heating at any time by switching off the power switch.
5. **Once the water has boiled**, the blue LED lights will turn off and the kettle will automatically power off.
6. **To serve, lift the kettle** off its base and pour.

OPERATING INSTRUCTIONS

SPECIAL SAFETY FEATURE: BOIL-DRY PROTECTION

The kettle comes equipped with boil-dry protection. While you should never heat the kettle without water at least to the MIN line, should the unit go dry or start without water, it will automatically shut off completely to avoid damaging the heating element. It will not come back on, even if you replace it to the base, until it has cooled down. To quickly cool it down, add cold water to the kettle.

TEA BREWING TIPS

- Use good-tasting water, preferably filtered, for best results.
- If using loose tea, use about 2 teaspoons of leaves per cup. If your loose tea comes with brewing instructions, defer to those initially for optimum amounts and steeping time.
- Add more or less tea leaves than suggested depending on how strong you like your “cuppa.”
- Tea should steep for 3 to 7 minutes on average, depending on the tea. Avoid steeping for too long, which can make tea taste bitter.
- If making iced tea, double the amount of tea leaves and steep a little longer so when chilled the flavor does not get weaker.
- Save money by re-steeping tea. Though black teas generally give up all their flavor during the first brew, some teas, like green tea and oolong, may be re-steeped within a few hours; let them steep a little longer during the second steep for best flavor.

CLEANING AND MAINTENANCE

1. Unplug the kettle and allow it to cool completely before cleaning.
2. Clean the interior of the kettle as needed by removing the lid and carefully washing the inside with soapy water. Rinse the inside of the kettle thoroughly. Wipe the outside of the kettle and the power base with a damp cloth, if necessary.
CAUTION: Never immerse the kettle or power base in water or wash in the dishwasher; doing so will damage the unit.
3. To clean the spout filter, rinse it under hot water while gently rubbing it with a clean cloth or brush. Do not attempt to remove the filter.

DESCALING

Due to minerals in water, deposits may form on the base of the kettle and cause discoloration. To get the best performance from your kettle, descale it from time to time. Frequency will depend on the hardness of your water and how often you use the kettle. You can either use a commercial descaler, following the package instructions, or use vinegar and water, and follow the directions below:

1. Fill the kettle with enough white vinegar to cover the bottom by about $\frac{1}{2}$ inch. Heat the vinegar to a boil.
2. Repeat this with fresh vinegar until all deposits are removed.
3. When the descaling process is complete, empty the kettle and rinse it out several times with clean water.

TERMS AND CONDITIONS

Limited Warranty

RJ Brands, LLC d/b/a Chefman® offers a limited 1-year Warranty (the “Warranty”) available on sales through authorized distributors and retailers only. Please note that this Warranty becomes valid from the date of initial retail purchase and that the Warranty is non-transferable and applies only to the original purchaser.

This Warranty is void without proof of purchase within the United States and Canada. Please be aware that this Warranty supersedes all other warranties and constitutes the entire agreement between the consumer and Chefman®. Any changes to the Terms and Conditions of this Warranty must be in writing, signed by a representative of Chefman®. No other party has the right or ability to alter or change the Terms and Conditions of this Warranty.

We may ask you to please submit, via email, photos and/or video of the issue you are experiencing. This is to help us better assess the matter and possibly offer a quick fix. Photos and/or video may also be required to determine Warranty eligibility.

We encourage you to register your product. Registering can make the Warranty process easier and can keep you informed of any updates or recalls on your product. To register, follow the directions on the Chefman® Warranty Registration page in the Chefman® User Guide. Please retain your proof of purchase even after registering. In the event that you do not have proof of your purchase date, we may declare your Warranty void or we may, at our sole discretion, apply the date of manufacture as the purchase date for purposes of this Warranty.

TERMS AND CONDITIONS

Limited Warranty

WHAT THE WARRANTY COVERS

- **Manufacturer Defects** - Chefman® products are warranted against defects in material and workmanship, under normal household use, for a period of 1 year from the date of purchase when used in accordance with the directions listed in the Chefman® User Guide. If your product does not work as it should, please contact Customer Support at support@chefman.com so that we may assist you.

THIS WARRANTY DOES NOT COVER

- **Misuse** - Damage that occurs from neglectful or improper use of products, including, but not limited to, damage that occurs as a result of usage with incompatible voltage, regardless of whether the product was used with a converter or adapter. See Safety Instructions in the Chefman® User Guide for information on proper use of product;
- **Poor Maintenance** - General lack of proper care. We encourage you to take care of your Chefman® products so that you may continue to enjoy them. Please see Cleaning and Maintenance directions in the Chefman® User Guide for information on proper maintenance;
- **Commercial Use** - Damage that occurs from commercial use;
- **Normal Wear and Tear** - Damage or degradation expected to occur due to normal use over time;
- **Altered Products** - Damage that occurs from alterations or modifications by any entity other than Chefman® such as the removal of the rating label affixed to the product;
- **Catastrophic Events** - Damage that occurs from fire, floods, or natural disasters; or
- **Loss of Interest** - Claims of loss of interest or enjoyment.

CHEFMAN® WARRANTY REGISTRATION

What do I need to register my product?

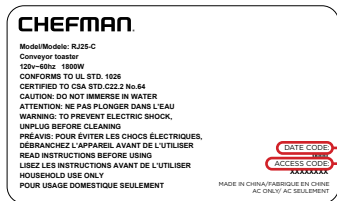

- Contact Information
- Model Number
- Proof of Purchase (online confirmation, receipt, gift receipt)
- Date Code
- Access Code

NOTE: Label depicted here is an example.

How do I register my product?

All you need to do is fill out a simple Chefman® registration form. You can easily access the form in one of the two ways listed below:

1. Visit Chefman.com/register.
2. Scan the QR code to access site:



CHEFMAN® WARRANTY REGISTRATION

For product information

Please visit us at Chefman.com.

EXCEPT WHERE SUCH LIABILITY IS REQUIRED BY LAW, THIS WARRANTY DOES NOT COVER, AND CHEFMAN® SHALL NOT BE LIABLE FOR, INCIDENTAL, INDIRECT, SPECIAL, OR CONSEQUENTIAL DAMAGES, INCLUDING WITHOUT LIMITATION, DAMAGE TO, OR LOSS OF USE OF THE PRODUCT, OR LOST SALES OR PROFITS OR DELAY OR FAILURE TO PERFORM THIS WARRANTY OBLIGATION. THE REMEDIES PROVIDED HEREIN ARE THE EXCLUSIVE REMEDIES UNDER THIS WARRANTY, WHETHER BASED ON CONTRACT, TORT OR OTHERWISE.

Chefman® is a registered trademark of RJ Brands, LLC.

Cooking Forward™ is a trademark of RJ Brands, LLC.

Chefman Boils Faster™ is a trademark of RJ Brands, LLC.

CHEFMAN®



CHEFMAN.COM | @MYCHEFMAN

©CHEFMAN 2023