

Champro®



110V AIR COMPRESSOR

MODEL NO: REBEL 65

PART NO: 2320422

OPERATION & MAINTENANCE INSTRUCTIONS

CE

ORIGINAL INSTRUCTIONS

GC0221 REV 1

INTRODUCTION

Thank you for purchasing this CLARKE 110V Air Compressor.

Read this manual fully before use and follow the instructions carefully. In doing so you will ensure the safety of yourself and those around you, and you can look forward to your purchase giving you long and satisfactory service.

GUARANTEE

This product is guaranteed against faulty manufacture for a period of 12 months from the date of purchase. Please keep your receipt which will be required as proof of purchase.

This guarantee is invalid if the product is found to have been abused or tampered with in any way, or not used for the purpose for which it was intended.

Faulty goods should be returned to their place of purchase, no product can be returned to us without prior permission.

This guarantee does not effect your statutory rights.

ENVIRONMENTAL RECYCLING POLICY



Through purchase of this product, the customer is taking on the obligation to deal with the WEEE in accordance with the WEEE regulations in relation to the treatment, recycling & recovery and environmentally sound disposal of the WEEE.







In effect, this means that this product must not be disposed of with general household waste. It must be disposed of according to the laws governing Waste Electrical and Electronic Equipment (WEEE) at a recognised disposal facility.

SAFETY PRECAUTIONS

Before using your compressor it is in your own interest to read and pay attention to the following safety rules.

1. Compressed air is dangerous. Do not point a jet of air at persons or animals, and do not discharge compressed air against the skin.
2. DO NOT operate your compressor with the guard removed.
3. Repairs must only be carried out by a qualified engineer. If problems occur, contact your Clarke dealer.
4. Before carrying out any maintenance, make sure that the pressure is released from the air reservoir, and that the compressor is disconnected from the electrical supply.
5. DO NOT leave pressure in the receiver overnight, or when transporting.
6. DO NOT adjust, or tamper with the safety valves. The maximum pressure is factory set, and clearly marked on the compressor.
7. DO NOT operate in wet or damp conditions. Keep the compressor dry at all times. Similarly, clean air will allow the compressor to work efficiently. Do not use in dusty or otherwise dirty locations.
8. Some of the metal parts can become quite hot during operation. Do not touch/ remove these until the compressor has cooled down.
9. Always set the pressure regulator to the recommended setting for the tool.
10. When spraying flammable materials e.g. cellulose paint, ensure that there is sufficient airflow and keep clear of any source of ignition.
11. Before spraying any material always consult paint manufacturers instructions for safety and usage.
12. Protect yourself. Goggles will protect your eyes from flying particles. Face masks will protect you against paint spray and fumes.
13. Do not apply strain to electrical cables and make sure that air hoses are not kinked or wrapped around the compressor.
14. When disconnecting air hoses or other equipment from your compressor, make sure that the air supply is turned off at the outlet and vent all pressurised air from within the reservoir and other equipment attached to it.
15. Make sure that children and animals are kept well away from the compressor and any equipment attached to it.
16. Make sure that all individuals using the compressor have had the necessary training and have read and fully understand these operating instructions.
17. Make sure that any equipment or tool used in conjunction with your compressor, has a safe working pressure exceeding that of the compressor.
18. Be careful when transporting the compressor to prevent tipping over
19. Permanently installed systems must be installed by a competent engineer.
20. This compressor produces noise levels in excess of 70dB(A). Persons working near the compressor must be supplied with ear protection.

SAFETY SYMBOLS

	<p>Read this instruction booklet carefully before positioning, operating or adjusting the compressor.</p>
	<p>Risk of electric shock. The compressor must be disconnected from the mains supply before removing any covers. Do not use in a damp environment.</p>
	<p>Risk of accidental start-up. The compressor could start automatically in the event of a power cut and subsequent reset. Do not carry the compressor while it is connected to the power source, or when the tank is filled with compressed air.</p>
	<p>This compressor contains surfaces which may reach a high temperature during operation. Never operate with the motor housing removed.</p>
	<p>Wear safety goggles and ear protectors when using this compressor</p>
	<p>This compressor produces a high sound level during operation. Ear protection should be worn.</p>

ELECTRICAL CONNECTIONS



WARNING: READ THESE ELECTRICAL SAFETY INSTRUCTIONS THOROUGHLY BEFORE CONNECTING THE PRODUCT TO THE MAINS SUPPLY.

Connect the mains lead to a suitable 110V (50Hz) electrical supply through an approved plug or a suitably fused isolator switch.

If using a portable 110V transformer, make sure it has a rated capacity sufficient to take the load of the air compressor.

ASSEMBLY



CAUTION: TO PREVENT INJURY, GET ASSISTANCE WHEN LIFTING THIS COMPRESSOR.

ATTACHING THE WHEELS

1. Slide the axle through the wheel and hole in the wheel frame.
2. Lock the wheel in place using the washer and nut provided.
3. Fit the cap into the position shown.

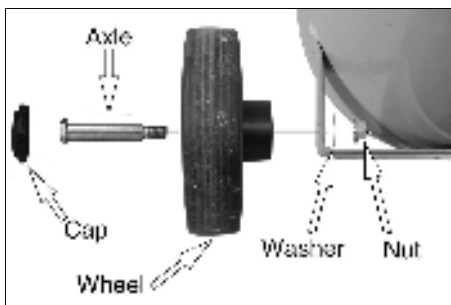

ATTACHING THE SUPPORT FEET

Insert the support feet into the position shown and secure using the nut supplied.

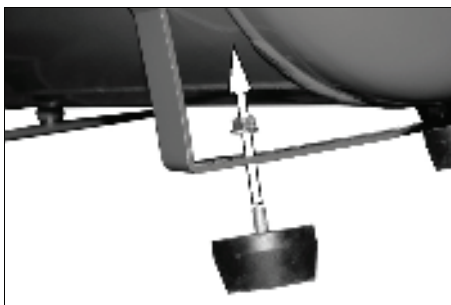

FITTING THE HANDLE

4. Loosen the bolts on either side and insert the handle into the brackets as shown.
5. Tighten the bolts.

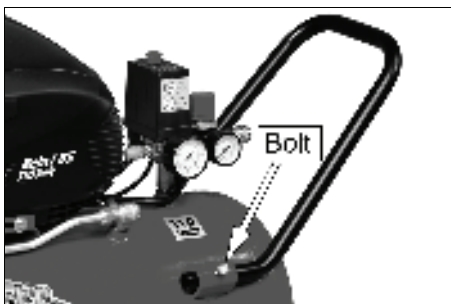

BEFORE USE

Before connecting your compressor to the power supply, check the following:-

- Push down the OFF button
- Make sure that the compressor is on level ground.
- Make sure that the supply voltage matches the voltage shown on the data label.



CHECK THE OIL LEVEL

1. Remove the dipstick from the oil reservoir.

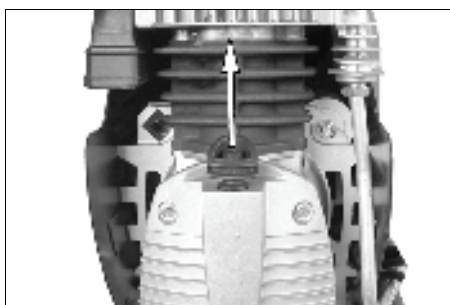

2. Ensure the oil level is between the min and max marks on the dipstick.

- Only use SAE30 compressor oil, available from your Clarke dealer Part No. 3050801.
- Take care not to fill above the maximum mark.

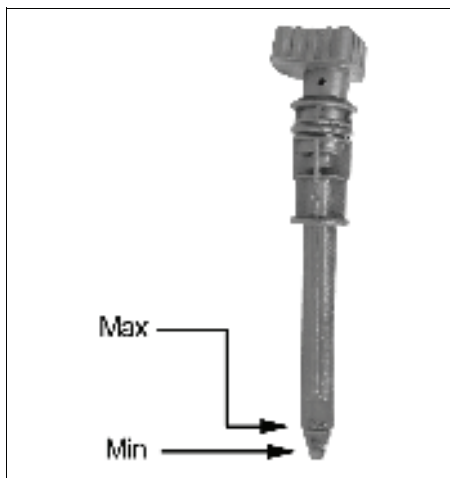

OPERATION

If the compressor has not been used for more than 24 hours, open the drain valve (on the bottom of the reservoir) and drain any condensate which has collected. See page 11.

MOVING THE AIR COMPRESSOR

- Stop the compressor and disconnect it from the power supply before you move it.
- Always use the handle.
- Do not lift by (or put strain on) valves or hoses.

ATTACHING AIR TOOLS



WARNING: BEFORE CONNECTING AIR TOOLS, MAKE SURE THAT YOU READ THE INSTRUCTIONS SUPPLIED WITH THE TOOL, ALSO ENSURE THAT THE TOOL IS SUITABLE FOR USE WITH THE COMPRESSOR AND HOSE SPECIFICATIONS.

1. Attach the air hose to the outlet valve.
2. Attach the air tool to the other end of the air hose.

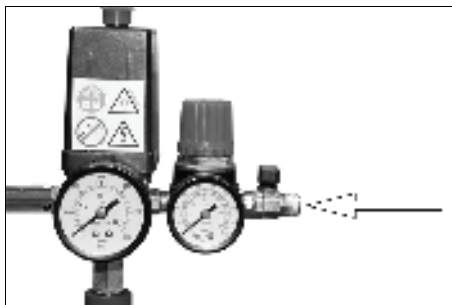

3. Turn the outlet valve handle to the on position.

NOTE: The outlet valve is shown without the air hose fitted for clarity.

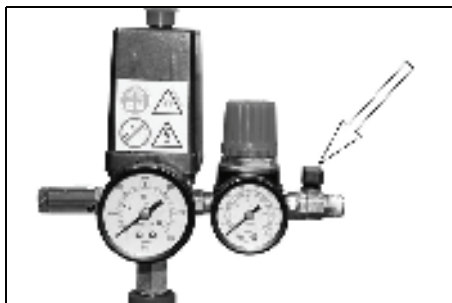

TURNING THE COMPRESSOR ON

1. Plug the compressor into the power supply.
2. Lift the On/Off button.
 - The compressor will operate until the reservoir is fully pressurised. It will then shut down.
 - The compressor will start up again when the pressure in the reservoir decreases.

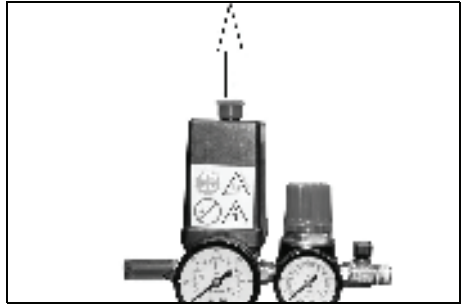

CHECKING THE SAFETY VALVE

To make sure that the safety valve works correctly.

1. Twist the knurled part of the safety valve.
 - Air will be released before the valve springs back to the closed position.
2. If the valve does not operate in this way, do not use the compressor. The compressor must be repaired by a qualified service agent.

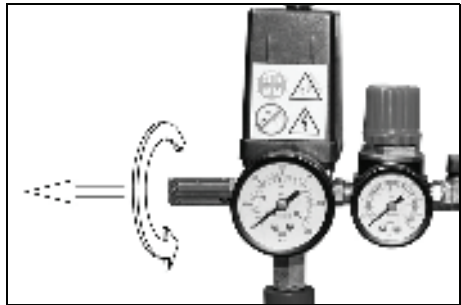

WARNING: DO NOT REMOVE OR TRY TO ADJUST THE SAFETY VALVE.

SETTING THE OUTLET PRESSURE

1. Use the pressure regulator to set the outlet pressure.
 - Turn clockwise to increase the pressure.
 - Turn counterclockwise to decrease the pressure.

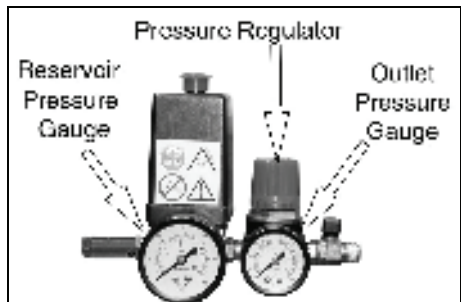

REMOVING TOOLS FROM THE AIR HOSE



WARNING: ALWAYS SET THE PRESSURE REGULATOR TO ZERO BEFORE YOU REMOVE OR REPLACE A TOOL.

1. Push down on the On/Off button to stop the compressor.



2. Turn the outlet valve handle to the off position.
3. Operate the tool to depressurise the air hose.
4. Disconnect the tool from the hose.

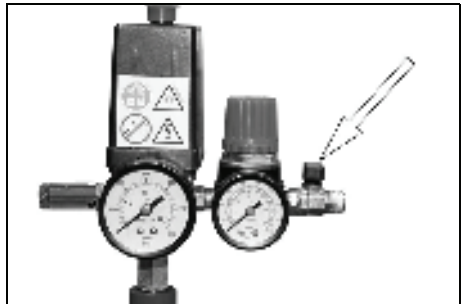

TURNING THE COMPRESSOR OFF

1. Follow steps 1-3 in "Removing Tools From The Air Hose" above.
2. Disconnect the compressor from the power supply.
3. Slowly open the outlet valve to depressurise the reservoir.
 - You will hear a hissing sound as the reservoir depressurises.
4. Do not leave the compressor unattended if the reservoir is pressurised.



DRAINING THE RESERVOIR



CAUTION: YOU MUST DRAIN THE RESERVOIR AFTER EACH DAYS USE AND BEFORE YOU PUT YOUR COMPRESSOR INTO STORAGE.

1. Turn the compressor off and disconnect from the power supply.
2. The drain valve is located on the bottom of the tank.
3. Put a container below the drain valve to collect the condensate.
4. Open the drain valve slowly.
 - Condensation will drain from the reservoir.
5. Close the drain valve when the reservoir has fully drained.

RESET BUTTON

This compressor has a thermal overload device.

If the motor gets too hot, the thermal overload device cuts the power which prevents damage to the motor.

If the thermal overload device operates, let the motor cool down for 5 minutes and push the reset button.

If you start the compressor and the overload cutout operates again, stop the compressor and disconnect from the power supply and have your compressor examined by a qualified service agent.

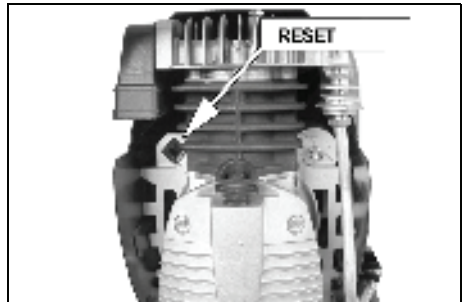

MAINTENANCE



WARNING: MAKE SURE THAT THE COMPRESSOR IS DISCONNECTED FROM THE ELECTRICAL SUPPLY BEFORE CARRYING OUT ANY MAINTENANCE.

DRAIN THE RESERVOIR (DAILY)

After use, always open the drain valve to make sure that any condensate is drained off.

Keep the cooling fins clear of dust if the machine is being used in a dirty workplace.

CHECK OIL (DAILY)

Ensure the oil level is between the min and max marks on the dipstick. See "Check the Oil level" on page 7 and top-up if necessary - (use Clarke SAE30 compressor oil, available from your local dealer).

CLEAN THE AIR FILTER (MONTHLY)

The air filter must be examined monthly, more often in dusty conditions,

1. Pull the filter away from the compressor.
2. Pull out the sponge filter element.
3. Clean the filter using a soft brush.
 - If necessary, the filter can be carefully cleaned in warm soapy water.
 - Rinse and let the filter dry completely before refitting.
 - If the filter or filter element is damaged, you must replace it.
4. Reassemble the filter and refit it to the compressor using the securing bolt.

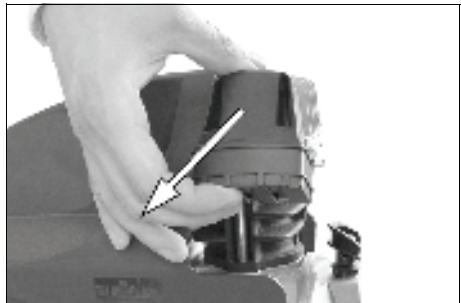

CAUTION: NEVER OPERATE THE COMPRESSOR WITHOUT THE SPONGE FILTER FITTED, AS FOREIGN MATTER COULD SERIOUSLY DAMAGE THE INTERNAL COMPONENTS. IF DAMAGED, THE FILTER SHOULD BE REPLACED.

REPLACING THE OIL

After the first 100 hours use, replace the oil using Clarke SAE30 compressor oil. Then replace the oil after every 500 hours of operation or every 6 months.

To empty the oil from the machine, remove the oil drain plug from the crankcase.



CHECK THE NON-RETURN VALVE (EVERY 6 MONTHS)

If the reservoir pressure decreases for no apparent reason, it is possible that the non-return valve is leaking. To check;

1. Make sure that the reservoir is not under pressure and the compressor is switched OFF.
2. Examine the non-return valve, and replace the gasket and valve if necessary.

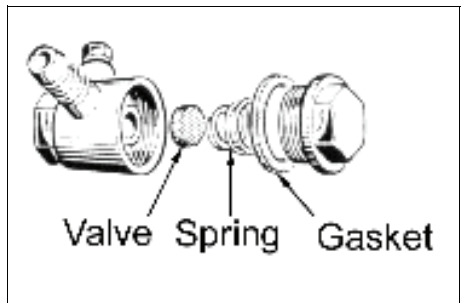
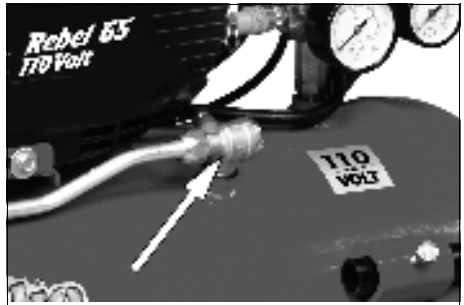

SPECIFICATIONS

REBEL 65

Part Number	2320422
Max Pressure	10 Bar
Voltage	110 VAC (50Hz)
Air Displacement	250 l/min
Receiver Capacity	50 L
Guaranteed Sound Power Level	97 dB(A)
Weight	32.4 kg

Please note that the details and specifications contained herein, are correct at the time of going to print. We reserve the right to change specifications at any time without prior notice.

TROUBLESHOOTING



CAUTION: DO NOT TRY TO REPAIR OR ADJUST THIS COMPRESSOR IF YOU ARE UNCERTAIN. IF YOU HAVE ANY QUERIES, CONTACT YOUR DEALER.

PROBLEM	PROBABLE CAUSE	REMEDY
The compressor has stopped and does not start.	Bad electrical connections.	<ol style="list-style-type: none"> 1. Check electrical connections. 2. Clean and tighten if necessary.
	Overload cutout switch has tripped.	<ol style="list-style-type: none"> 1. Switch off and wait approx 5 minutes. 2. Press the reset button and switch on again.
	Motor windings burnt out.	<ol style="list-style-type: none"> 1. Contact your Clarke dealer for a replacement motor.
The compressor does not reach the set pressure and overheats.	Compressor head gasket blown or valve broken.	<ol style="list-style-type: none"> 1. Return the machine to your nearest service agent.
Compressor does not start.	The reservoir has already fully pressurised.	<ol style="list-style-type: none"> 1. Open drain valve to expel air. Compressor should start again when pressure reduces.
Air leaking from the non-return valve when the compressor is not running.	Faulty non-return valve.	<ol style="list-style-type: none"> 1. Drain receiver completely of air. 2. Remove the valve end plug, 3. Carefully clean the valve seat and the gasket 4. Reassemble.
Air pressure from the regulator will not adjust.	The diaphragm within the regulator body is broken.	<ol style="list-style-type: none"> 1. Replace regulator.
The compressor is very noisy and makes a metallic knocking sound.	Compressor damaged and needs overhaul.	<ol style="list-style-type: none"> 1. Return the machine to your nearest service agent.

EXPLODED DIAGRAM

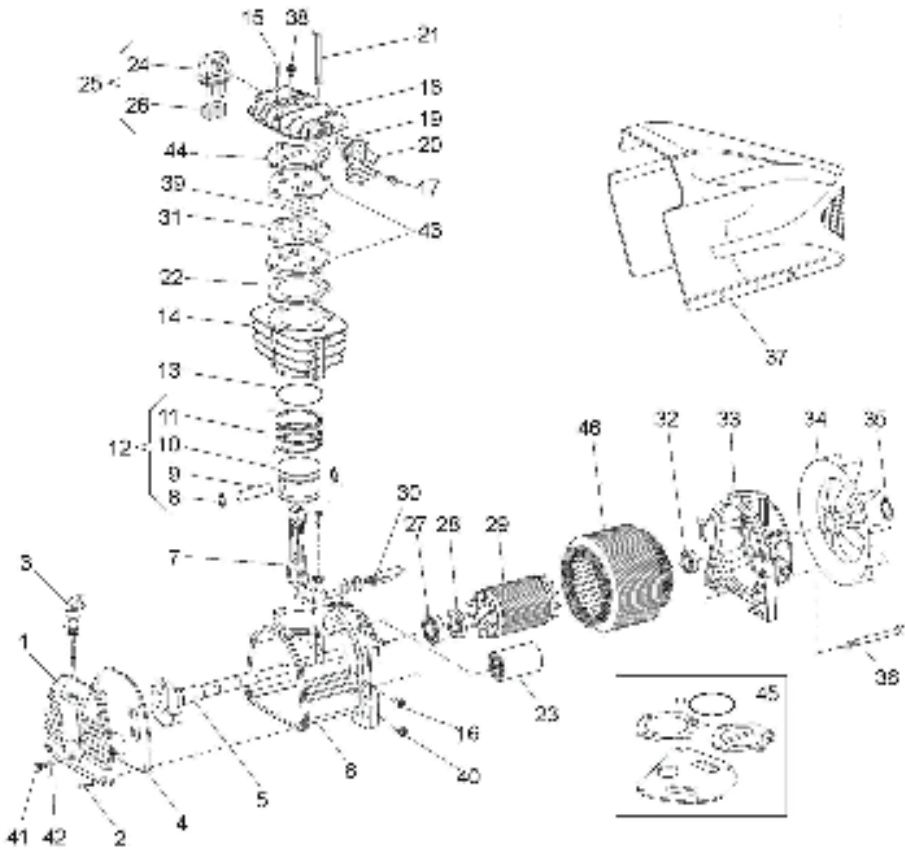

PARTS LIST - COMPRESSOR

No	Description	Part No
1	END COVER	FN116CN0025
2	BOLT	FN114006024
3	PLUG/DIPSTICK	FN012089000
4	CRANKCASE GASKET	FN116120016
5	CRANKSHAFT	FN116CN0017
6	CRANKCASE	FN116120006
7	CONNECTING ROD	FN116121005
8	CIRCLIP	FN015001000
9	GUDGEON PIN	FN116022040
10	PISTON	FN116022004
11	PISTON RINGS	FN216022002
12	PISTON ASSY	FN416022004
13	O-RING	FN010133000
14	CYLINDER BODY	FN116CN0015
15	SCREW	FN014013031
16	NUT	FN014003001
17	SCREW	FN014013021
18	CYLINDER HEAD	FN116CN0013
19	O-RING	FN010130000
20	MANIFOLD	FN016NC1004
21	BOLT	FN014001075
22	CYL GASKET	FN116NC0006
23	CONDENSER	FN009200035

No	Description	Part No
24	AIR FILTER HOUSING	FN017082002
25	INLET FILTER ASSY	FN317082000
26	FILTER ELEMENT	FN017082001
27	BEARING	FN033082000
28	SEALING RING	FN010132000
29	MOTOR ROTOR	FN116093005
30	OVERLOAD CUTOUT	FN0080055000
31	VALVE GASKET	FN116CN0051
32	BEARING	FN033005000
33	REAR COVER	FN116120007
34	FAN	FN116120008
35	CIRCLIP	FN015083000
36	LONG BOLT	FN014002128
37	HOUSING	FN116NC0003
38	SAFETY VALVE	FN011000183
39	VALVE BLADE	FN116022038
40	NUT	FN1611900100
41	SCREW	FN014013024
42	O-RING	FN010072000
43	VALVE PLATE	FN116CN0030
44	HEAD GASKET	FN116120014
45	GASKET SET	FN216CN0002
46	STATOR	FN316CN1601

DECLARATION OF CONFORMITY



Clarke[®]
INTERNATIONAL

1 Grand Street, Spring Data, Ohio, U.S.A

DECLARATION OF CONFORMITY

This is an important document and should be retained.

Directive(s):

- 2006/95/EC Machinery Directive
- 2002/95/EC Waste Electricals Directive (amended by 2002/96/EC)
- 2014/53/EU Electromagnetic Compatibility Directive
- 2011/65/EU Restriction of Hazardous substances

Standard (s):

EN 16147-1, EN 60954-1, EN 60950-2-3, EN 61689-2-1

The technical documentation required to demonstrate that the product(s) meet(s) the requirement(s) of the aforementioned directive(s) has been compiled and is available for inspection by the relevant enforcement authorities.

The CE mark was first applied in: 2018

Signed:



J.A. Clarke
Director

Date of issue:

02/08/2018

Place of issue:

Clarke International
Hemwell Road
Epsom
Essex, CM18 4UG
England

A SELECTION FROM THE VAST RANGE OF

Clarke®

QUALITY PRODUCTS



AIR COMPRESSORS
From DIY to industrial, plus air tools,
spray guns and accessories.

GENERATORS
Prime duty or emergency standby
for business, home and leisure.

POWER WASHERS
Hot and cold, electric and engine
driven - we have what you need.

WELDERS
Mig, Arc, Tig and Spot,
from DIY to industrial class.

METALWORKING
Drills, grinders and saws for DIY
and professional use.

WOODWORKING
Saws, sanders, lathes, mortisers
and dust extraction.

HYDRAULICS
Cranes, body repair kits,
transmission jacks for all types of
workshop use.

WATER PUMPS
Submersible, electric and engine driven
for DIY agriculture and industry.

POWER TOOLS
Angle grinders, cordless drill sets,
saws and sanders.

STARTERS/CHARGERS
All sizes for car and commercial use.



**PARTS & SERVICE:
0208 988 7400**

Parts Enquiries
Parts@clarkeinternational.com

Servicing & Technical Enquiries
Service@clarkeinternational.com

SALES: UK 01992 565333 or Export 00 44 (0)1992 565335

Clarke INTERNATIONAL Hornall Street, Epping, Essex CM18 4LG
www.clarkeinternational.com