

# 180UC-3

## Quick Setup Instructions



180UC-3 REAR VIEW

**WARNING:** Electrical and plumbing connections need to be made by a qualified service technician and comply with all available Federal, State and Local Health, Electrical, Plumbing and Safety codes.

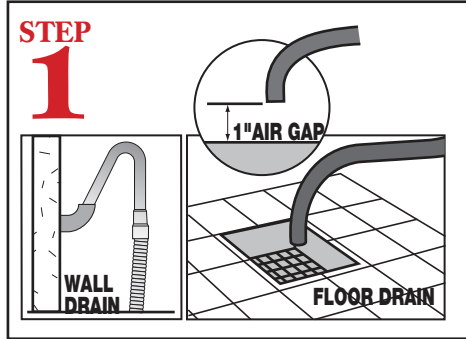
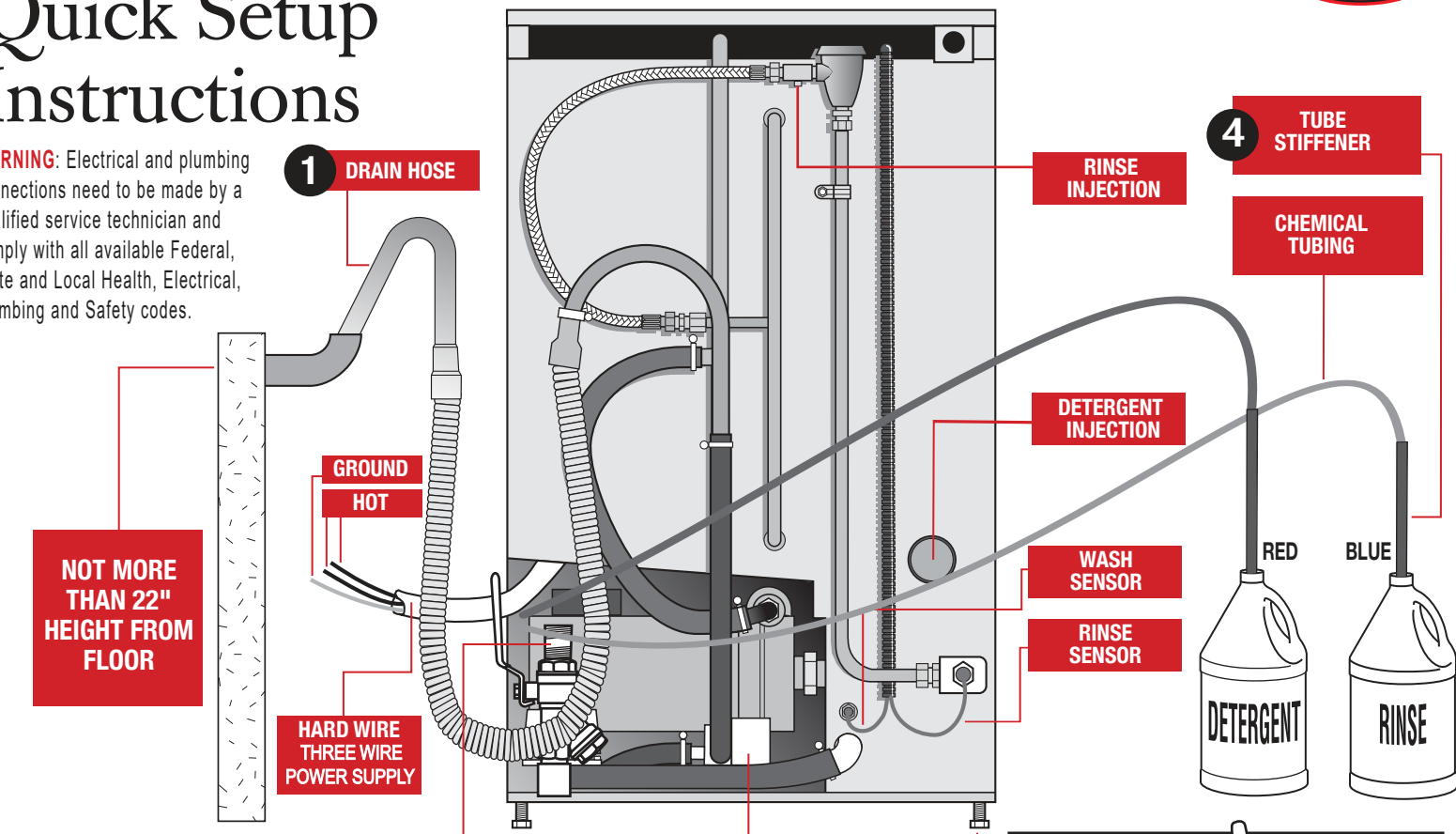

Connect the drain hose to wall, not higher than 22 inches, or floor drain. The drain hose should have a 1 inch air gap between drain hose and drain.

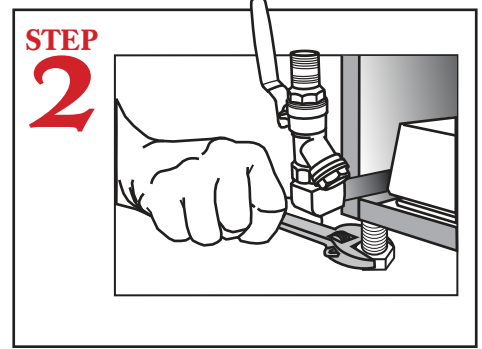

Level dishmachine by adjusting leveling legs. Dishmachine must be level front and back and side to side.

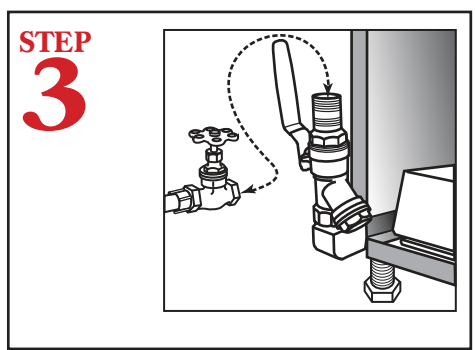

Connect dishmachine to hot water source, recommended minimum temperature 140°F. Unit will remain in wash cycle until booster heater temperature reaches 180°F, then it will advance into rinse cycle.

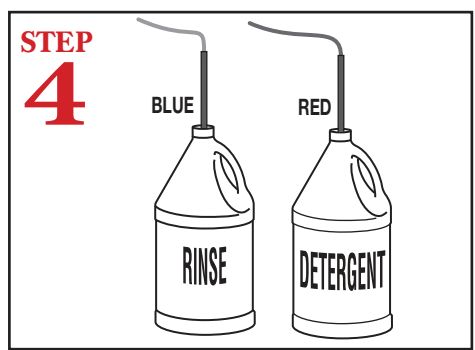

Insert tube stiffener with chemical tubing into corresponding chemical dispensers.

# 180UC-3 Quick Setup Instructions

180UC-3 FRONT VIEW



**WARNING:** Electrical and plumbing connections need to be made by a qualified service technician and comply with all available Federal, State and Local Health, Electrical, Plumbing and Safety codes.

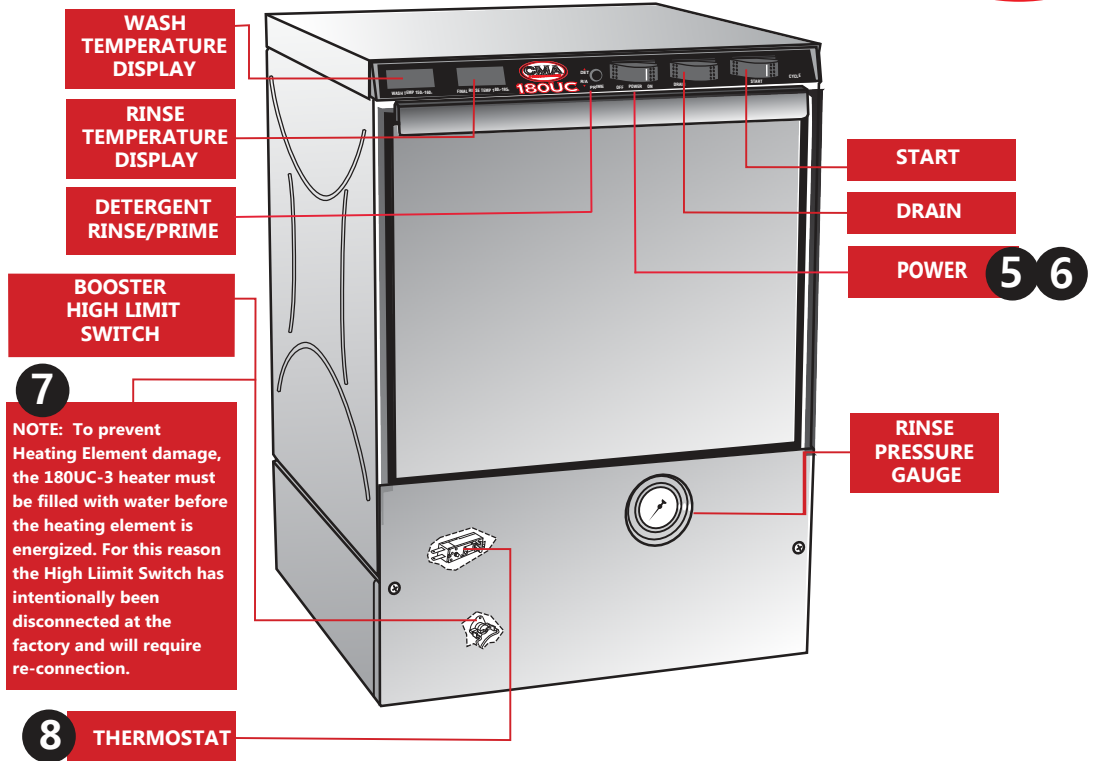

**7**  
NOTE: To prevent Heating Element damage, the 180UC-3 heater must be filled with water before the heating element is energized. For this reason the High Limit Switch has intentionally been disconnected at the factory and will require re-connection.



**INITIAL START UP INSTRUCTIONS.**  
Press power switch to ON position. Listen for water spraying into the machine. Check wash tank for water, if none repeat till wash tank full. Installer responsible to adjust fill timer.

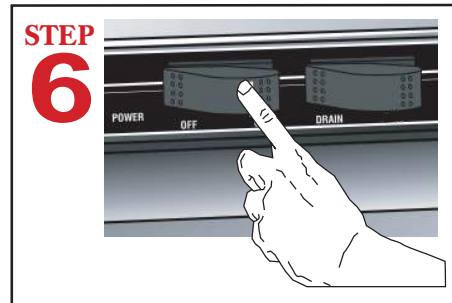

**DAILY START PROCEEDURE.**  
Press power switch on. Machine will automatically fill wash tank. Installer responsible to adjust fill timer. Allow machine 10 minutes for wash tank temperature display to read 160f.

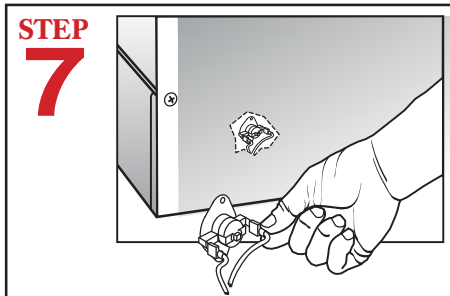

After filling dishwasher for the first time, (**CAUTION: turn power supply off**) reconnect the factory unplugged wire to booster high-limit switch located behind front panel.

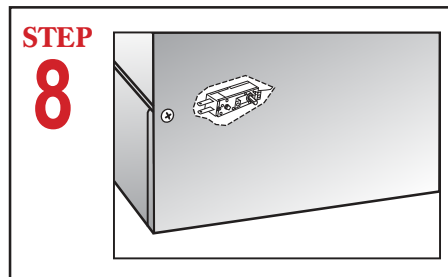

Turn power supply back on. Allow machine to heat up (about 10 minutes). Cycle machine by pushing start switch. Observe "Rinse Cycle" (last 12 seconds of cycle) must be minimum 180°F. If necessary adjust the temperature by turning the adjustment stem on booster thermostat clockwise to increase.