



MODELS CMA-180/180TALL
Including 480V MACHINES
PARTS MANUAL
Rev 2.09 12-15-24



CMA DISHMACHINES
17707 VALLEY VIEW AVE
CERRITOS, CALIFORNIA 90703
800-854-6417
FAX 714-895-2141

www.cmadishmachines.com

[Buy Parts](#)

TABLE OF CONTENTS

MODEL CMA-180

1. PARTS MANUAL	3
1.1 INITIAL PARTS KIT #1100.17	3
1.2. EXPLODED VIEW DRAWINGS.....	4
1.2.1. Straight Frame System Assembly.....	4
1.2.2. Corner Frame Assembly.....	5
1.2.3. Drain System Assembly.....	6
1.2.4. Plumbing System Assembly.....	7 & 8
1.2.5. Wash Spray System.....	9
1.2.6. Final Rinse System	10
1.2.7. CMA-180 Door Handle Assembly	11
1.2.8. Corner Door Handle Assembly.....	12
1.2.9. Pump System Assembly.....	13
1.2.10. Old Wash Tank Heater (Square Flange).....	14
1.2.11. Old Booster Heater (Square Flange).....	15
1.2.12. New Wash Tank Heater (Triangular Flange).....	16
1.2.13. New Booster Heater (Triangular Flange).....	17
1.2.14. 480 Control Box Assembly.....	18
1.2.15. Control Box Assembly.....	19&20
1.2.16. Unique Parts For CMA-180TS.....	21
1.2.17. Unique Parts For CMA-180TC	22
1.2.18. Unique Parts for CMA-180T Split Door.....	23
2. POWER SWITCH BULB REPLACEMENT INSTRUCTIONS.....	24
3. 180 CONVERSION KIT – CORNER TO STRAIGHT #00617.18.....	25
4. 180 CONVERSION KIT – STRAIGHT TO CORNER #00617.17.....	26
5. Drain Water Tempering Valve Assembly (Effective 03-2023).....	27

1. Parts Manual

1.1 Initial Parts Kit #1100.17

P/N	DESCRIPTION	Qty
00121.18	CMA-180 Drain Stopper O-ring	1
00200.10	Pump Assy. 115/220V 60Hz (Open)	1
00206.30	Pump Seal Kit	1
00304.29	Rinse Arm w/ Bearings	1
00307.20	Spray Arm Assy CMA180 w/ bearing & end plugs	1
00363.00	Spray Base Pull Lock Pin	1
00404.85	Contactora 208/240V 20 Amp DP	1
00411.00	Micro Switch	1
00421.78	Illuminated Plug CMA-180/44 P	1
00421.90	Power Switch Red 250V	1
00475.70	Toggle Switch DPDT 15 Amp/Delimer	1
00501.17	Timer Motor Assy 60 Sec 220V/60Hz	1
00562.00	Roller Door Switch	1
00602.00	Door Spring	1
00631.05	Ice Cube Relay 220V 12 Amp	1
00706.00	3/4 Water Solenoid Repair Kit JE	1
00735.00	3/4 Vac Breaker Rep Kit Watts	1
00738.15	Solenoid Coil JE 220V (3/4 & 1/2)	1
03202.00	Thermometer (Capillary)	1
03408.55	Counter - Face Mount 220V/50Hz	1
03470.00	Toggle Switch (Momentary) Screw Term	1
13003.17	Contactora 60 Amp 3 Pole	1
13003.55	Contactora 30 Amp	1
13304.55	SS Final Rinse Spray Jet SS	1
13417.92	Heater Thermostat	1
13422.71	Immersion Heater 208-240V/12kW T-Flange	1
13463.14	Liquid Level Switch-Long-D Flat	1
13605.00	Pressure Gauge	1
15518.00	Immersion Heater 6kW208-240V T-Flange	1
17523.51	Hi Limit Switch 250 Deg	1

1.2. Exploded View Drawings

1.2.1. Straight Frame System Assembly

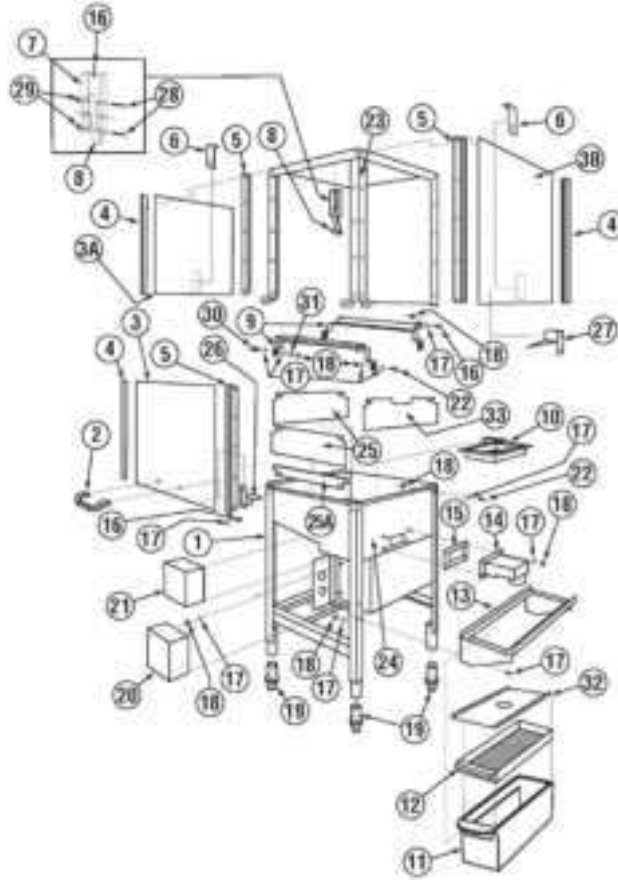

ITEM NO.	NO. REQ'D	P/N	DESCRIPTION
1	1	17532.17	CMA-180 Frame Stand
2	1	00535.30	Front door Handle
3	3	01506.08	Door, Oval W/ Dimple
4	6	00636.15	E Z Door Glide
5	6	17554.00	Door Guide
6	2	17552.00	Door Stop
7	1	13915.60	Door Latch Bracket
8	1	13701.00	Open Door Latch
9	1	01505.02	Tray Track (Set)
10	2	17510.00	Strainer Basket
11	1	01577.10	Scrap Tray Body
12	1	01577.21	Scrap Trap Drawer
13	1	17579.00	Scrap Trap Holder
14	1	17511.00	Overflow
15	1	17402.00	Overflow Gasket
16	30	00905.00	1/4-20 x 1/2 Trus Bolt
17	60	00924.00	1/4" SS Washer

ITEM NO.	NO. REQ'D	P/N	DESCRIPTION
18	30	00912.00	1/4"-20 Nylon Lock Nut
19	4	01310.00	Bullet Feet
20	1	17521.50	Wash Tank Heater Cover Poly Pro
21	1	17521.20	Booster Heater Cover Poly Pro
22	23	00914.10	1/4-20 X 5/8 Hex Bolt
23	1	17530.17	CMA-180 Wrapper
24	1	17531.17	Pan
25	2	17506.60	Door Panel Splash Guard
25A	1	17506.65	Door Service Splash Guard
26&27	2	17506.21	Front Door Safety Bracket
28	1	00960.00	8-32x1-1/2" Panhead Screw
29	1	00927.00	8-32 Nylon Lock Nut
30	2	00962.00	1/4-20 X 1 SS Hex Bolt
31	4	00610.00	Door Handle Spacer (Small)
32	1	01577.30	S/S Scrap Trap Lid
33	1	17506.62	180 Splash Shield - lever side

1.2.2. Corner Frame Assembly

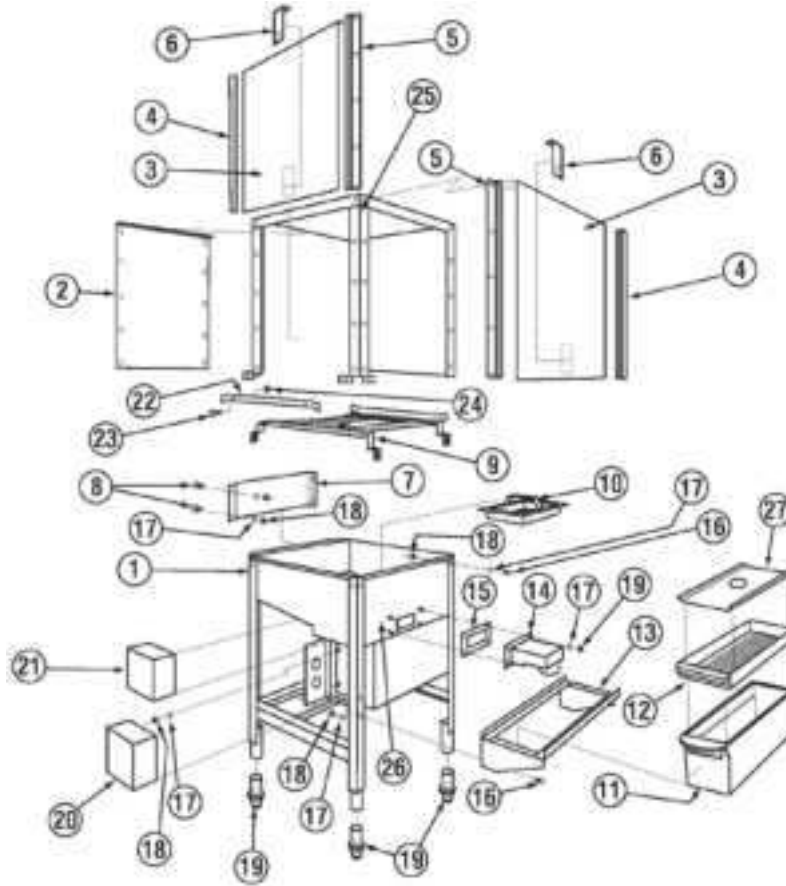

ITEM NO.	NO. REQ'D	P/N	DESCRIPTION
1	1	17532.17	CMA-180 Frame Stand
2	1	17506.50	Door Panel Corner
3	2	01506.08	Door, Oval W/ Dimple
4	4	00636.15	E Z Door Glide
5	4	17554.00	Door Guide
6	2	17552.00	Door Stop
7	1	17507.20	Air Gap Baffle
8	4	00905.00	¼" – 20 x ½ Truss Head Bolt
9	1	01505.10	Tray Track
10	2	17510.00	Strainer Basket
11	1	01577.10	Scrap Trap Body
12	1	01577.21	Scrap Trap Drawer
13	1	17579.00	Scrap Trap Holder

ITEM NO.	NO. REQ'D	P/N	DESCRIPTION
14	1	17511.00	Overflow
15	1	17402.00	Overflow Gasket
16	24	00906.00	¼"-20 x 1/2" Hex Head Bolt
17	56	00924.00	¼" SS Washer
18	30	00912.00	¼"-20 Nylon Lock Nut
19	4	01310.00	Bullet Feet
20	1	17521.50	Wash Tank, Heater Cover Poly
21	1	17521.20	Booster Heater Cover Poly Pro
22	1	01505.16	Tray Track Rail
23	2	00941.00	8/32" x 5/8" Pan Head Screw
24	2	03801.00	10/32" Lock Nut
25	1	17530.17	CMA-180 Wrapper
26	1	17531.17	Pan
27	1	01577.30	S/S Scrap Trap Lid

1.2.3. Drain System Assembly

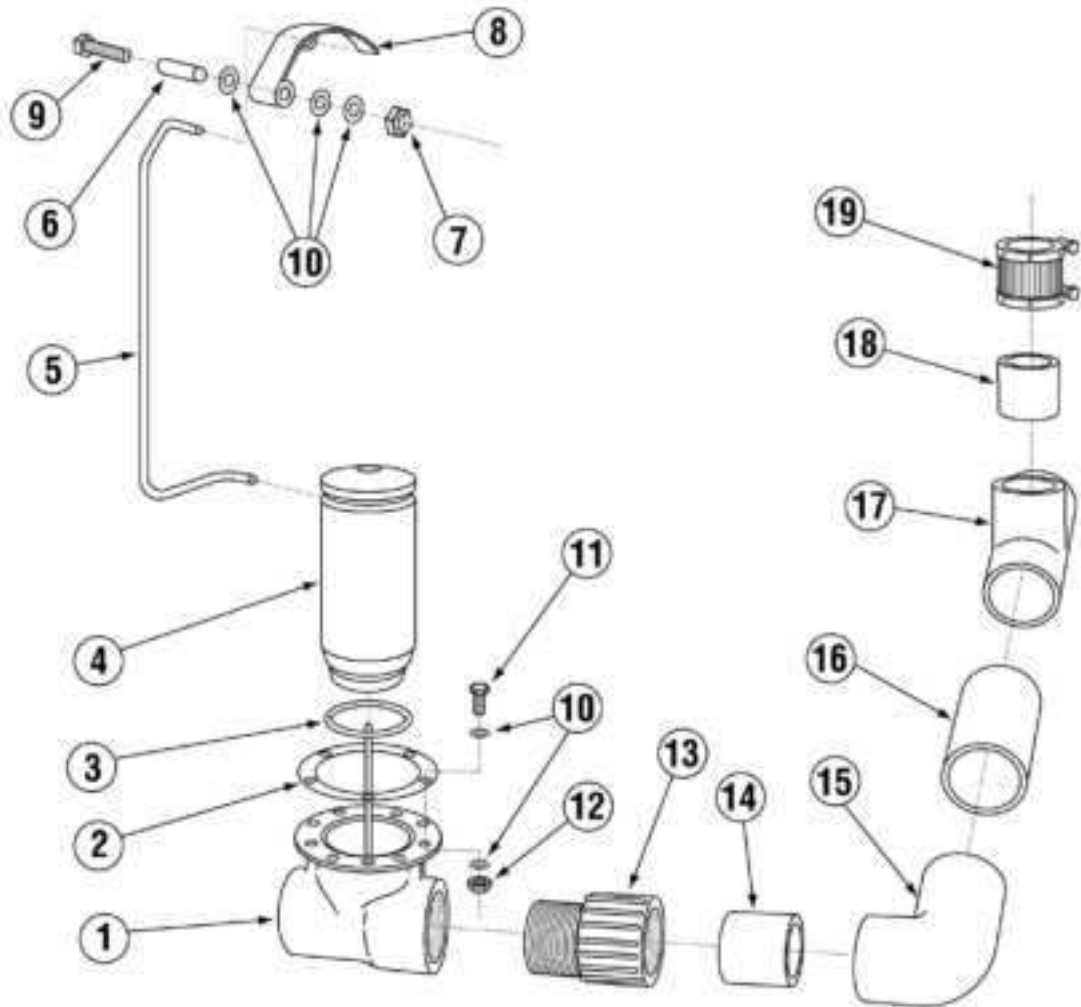

ITEM NO.	NO. REQ'D	P/N	DESCRIPTION
1	1	00113.17	Drain Tee Casting
2	1	00114.00	Drain Tee Gasket
3	1	00121.18	Drain Stopper "O" Ring
*4	1	00121.17	Drain Stopper (Incl O-Ring)
5	1	17581.00	Drain Linkage
6	1	17580.50	Drain Linkage Spacer
7	1	00912.00	1/4"-20 Nylon Lock Nut
8	1	17580.00	Drain Lever
9	1	00910.00	1/4"-20x1 1/2" Hex Head Bolt
10	16	00926.00	5/16 S/S Washer

*P/N 00121.17 includes P/N 00121.18

ITEM NO.	NO. REQ'D	P/N	DESCRIPTION
11	6	00901.00	5/16 -18x1" Hex Head Bolt
12	6	13805.00	5/16-18 Nylon Lock Nut
13	1	01313.00	2" PVC Slip x MIPT Adapter
14	1	05030.17	2" x 4" PVC Tubing
15	1	01312.00	PVC Slip x Slip 90 Elbow
16	1	05030.27	2" x 6" PVC Tubing
17	1	01320.17	2" PVC Tee
18	1	05030.10	2" x 3" PVC Tubing
19	1	01315.17	2" No Hub

1.2.4. Plumbing System Assembly

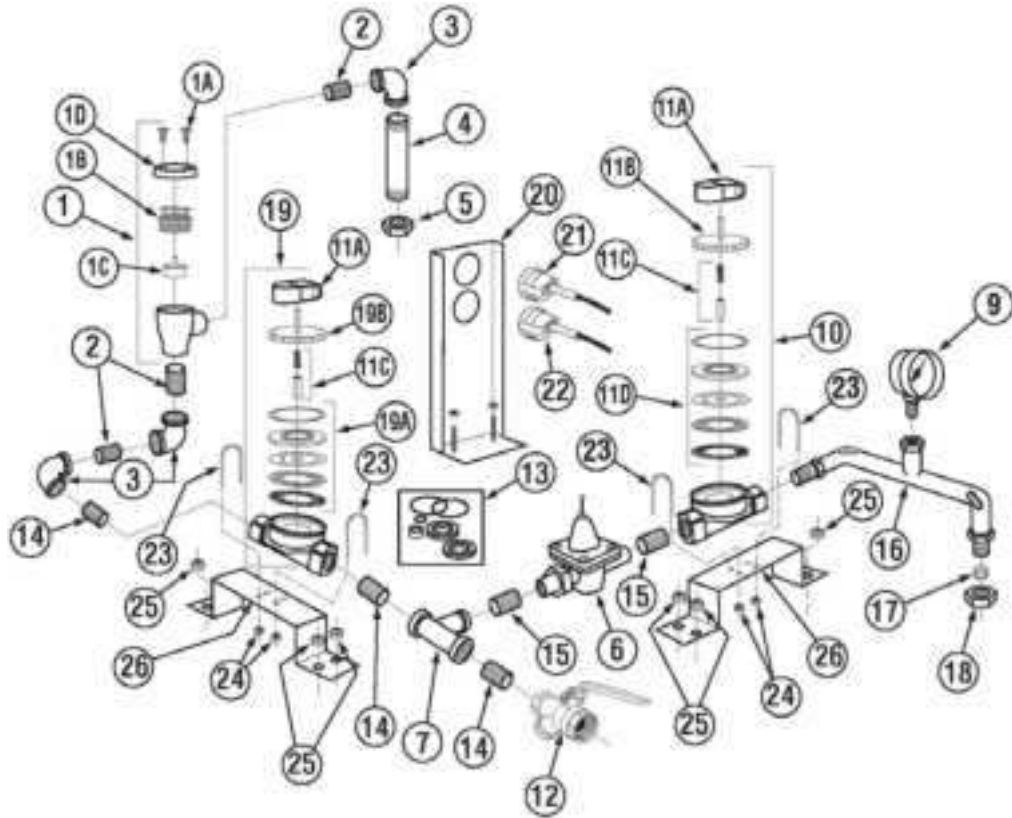

ITEM NO.	NO. REQ'D	P/N	DESCRIPTION
1	1	00710.50	Vacuum Breaker 3/4" Watts
1A	--	00421.51	Pan Head Screw SS 6-32 x 1/4"
1B	--	00735.60	Vacuum Breaker Brass Bonnet
1C	--	00735.00	Vacuum Breaker Repair Kit 3/4"
1D	--	00739.50	Vacuum Breaker Cap
2	3	13639.00	Nipple SS 3/4" Close
3	3	13633.00	Elbow FXF Brass 3/4"
4	1	13613.00	Nipple 3/4" x 5 1/2" Brass
5	2	13606.10	Jamb Nut Brass 3/4"
6	1	13602.28	Pressure Regulator 1/2"
7	1	00716.10	Brass Tee 3/4" x 3/4" x 1/2" FXXF
8	1	13604.00	Bushing 1/2" x 1/4" Brass
9	1	13605.00	Pressure Gauge
10	1	03603.15	Water Sol Valve 1/2" 220V JE-C
11A	1	00738.15	Water Sol Valve Coil 220V
11B	--	03603.20	Water Sol Valve Bonnet 1/2"
11C	--	00786.00	Water Sol Plunger G Style
11D	--	00707.00	Water Sol Repair Kit JE 1/2"

ITEM NO.	NO. REQ'D	P/N	DESCRIPTION
12	1	13029.00	Strainer Ball Valve 3/4"
13	--	13028.00	3/4" Ball Valve Repair Kit
14	2	13635.10	Nipple Brass 2/4" x 2"
15	4	00742.00	Nipple 1/2" x 1 1/2"
16	1	13607.50	Final Rinse Plumbing
17	1	00770.20	5/8 Compression Ftg. Ring
18	1	00770.10	5/8 Compression Ftg. Nut
19	-	00705.05	Water Sol Valve 3/4" 220V JE
19A	-	00706.00	Water Sol Repair Kit JE 3/4"
19B	-	00705.20	Water Sol Valve Bonnet 3/4"
20	1	17534.00	180 Thermometer Bracket
21	1	03202.00	Thermometer "Wash"
22	1	03202.18	Thermometer "Rinse"
23	4	01526.10	Plumbing Bracket Strap
24	4	00912.00	1/4-20 Nylon Lock Nut
25	8	00912.00	1/4-20 Nylon Lock Nut
26	2	01526.00	Plumbing Support Bracket

1.2.4. Plumbing System Assembly Starting May 2023

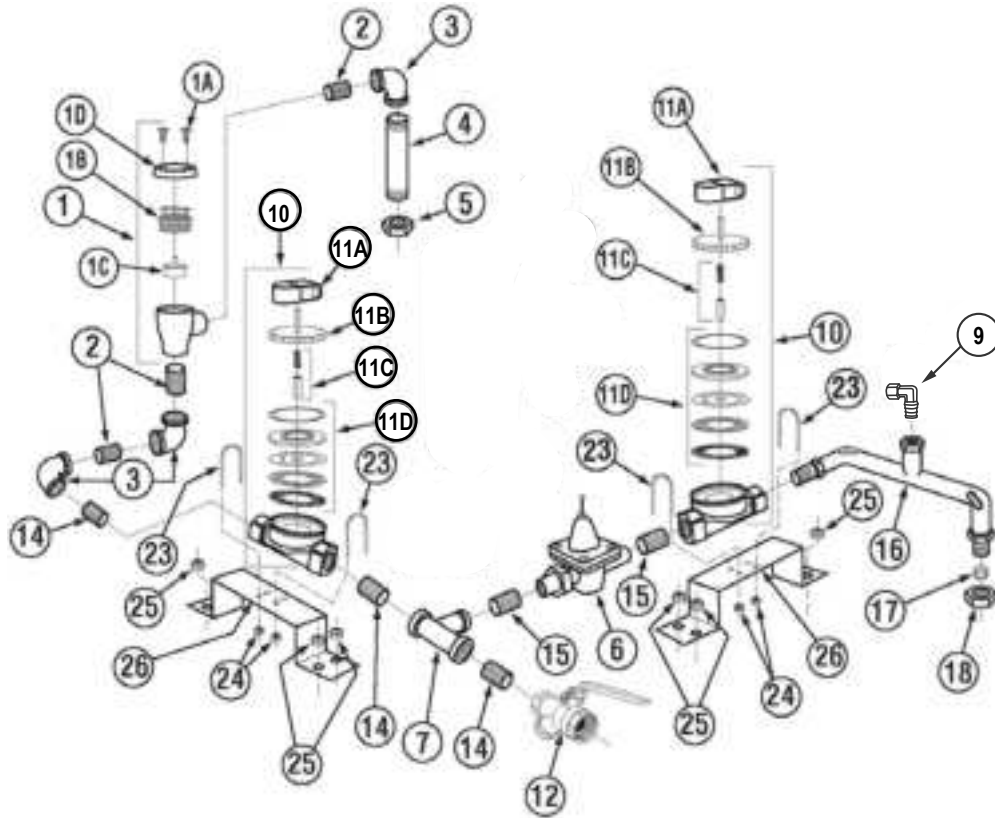

ITEM NO.	NO. REQ'D	P/N	DESCRIPTION
1	1	03624.00	Vacuum Breaker 1/2" Watts
1A	--	00421.51	Pan Head Screw SS 6-32 x 1/4"
1B	--	03624.25	Vacuum Breaker Brass Bonnet
1C	--	03623.00	Vacuum Breaker Repair Kit 1/2"
1D	--	00739.50	Vacuum Breaker Cap
2	3	03614.00	Nipple Brass 1/2" Close
3	3	41030.10	Elbow FxF Brass 1/2"
4	1	00747.10	Nipple 1/2" x 5" Brass
5	2	00721.20	Jamb Nut Brass 1/2"
6	1	13602.28	Pressure Regulator 1/2"
7	1	00743.10	Brass Tee 1/2"x1/2"x1/2" FxFxF
9	1	40112.00	1/4 Comp x 1/4 MIP Elbow
10	1	03603.15	Water Sol Valve 1/2" 220V JE-C
11A	1	00738.15	Water Sol Valve Coil 220V
11B	--	03603.20	Water Sol Valve Bonnet 1/2"
11C	--	00786.00	Water Sol Plunger G Style
11D	--	00707.00	Water Sol Repair Kit JE 1/2"

ITEM NO.	NO. REQ'D	P/N	DESCRIPTION
12	1	41062.00	Strainer Ball Valve 1/2"
14	2	00780.00	Nipple Brass 1/2" x 2 1/2"
15	2	00742.00	Nipple 1/2" x 1 1/2"
16	1	13607.50	Final Rinse Plumbing
17	1	00770.20	5/8 Compression Ftg. Ring
18	1	00770.10	5/8 Compression Ftg. Nut
23	4	01526.10	Plumbing Bracket Strap
24 & 25	12	00912.00	1/4-20 Nylon Lock Nut
26	2	01526.00	Plumbing Support Bracket

1.2.5. Wash Spray System

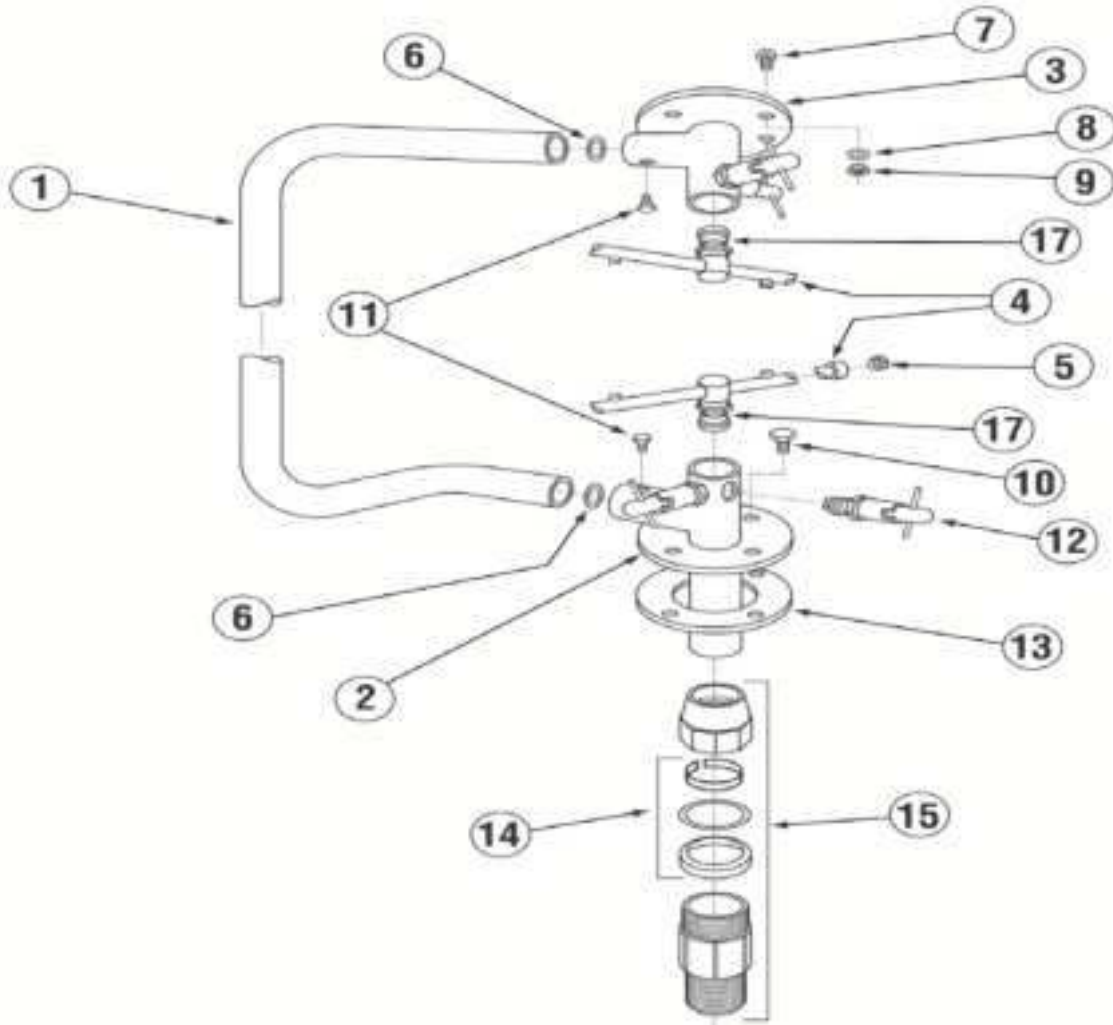

ITEM NO.	NO. REQ'D	P/N	DESCRIPTION
1	1	00303.17	Manifold
*2	1	00360.24	Lower Spray Base Assembly
**3	1	00361.10	Upper Spray Base Assembly
4	2	00304.17	Wash Spray Arm
5	4	00308.50	Spray Arm End Plug SS
6	2	00302.51	Spray Base "O" Ring
7	4	00905.00	Truss Head Bolt 1/4"-20"x1/2"
8	12	00924.00	SS Washer 1/4"

ITEM NO.	NO. REQ'D	P/N	DESCRIPTION
9	8	00912.00	Nylon Lock Nut 1/4" – 20
10	4	00914.10	Hex Head Bolt 1/4"-20"x5/8"
11	2	00966.10	Hex Head SS Bolt 10-32
12	4	00363.00	Spray Base Lock Pin
13	1	00302.00	Spray Base Gasket
14	1	00225.00	Compression Gasket
15	1	00221.20	1" Comp. Fit.x1"MIP SS
16	1	00759.17	Base Quick Release W/Nipple
17	2	00341.00	Spray Arm Bearing

**P/N 00361.10 Includes Items 11,12 & 6

*P/N 00360.24 Includes Items 11, 12 & 6

1.2.6. Final Rinse System

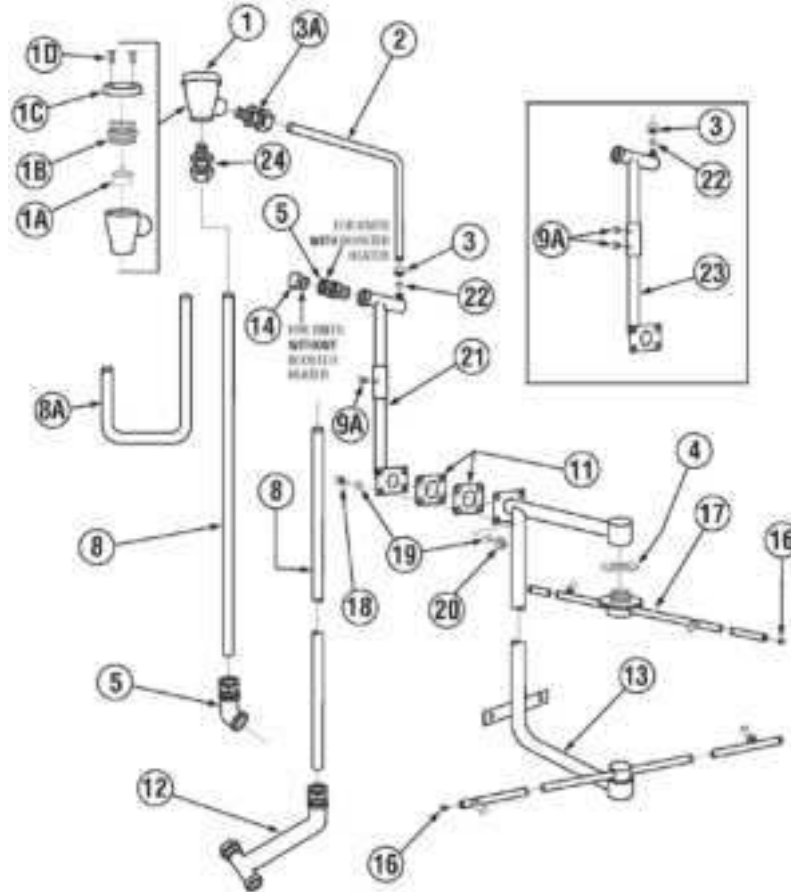

ITEM NO.	NO. REQ'D	P/N	DESCRIPTION
1	1	03624.00	1/2" Vacuum Breaker Watts
1A	--	03623.00	1/2" Vacuum Brkr Kit- Watts
1B	--	03624.25	1/2" Brass Bonnet
1C	--	00739.50	3/4" Vacuum Breaker Cap SS
1D	--	00421.51	6-32 x 1/4" SS Pan Head Screw
2	1	05004.10	3/8" SS Tubing
3	1	13607.10	3/8" Comp x 1/2" MIP Elbow
3A	1	00436.20	Comp Fitting Nut
4	2	04305.17	Bearing Gasket
5	1	17550.11	Outlet Booster Heater Plumbing
6	1	13629.00	1/2" S.S. Close Nipple
7	1	13629.82	Nipple SS 1/2" x 5 1/2"
8	2	05007.17	5/8" OD .049 Wall Tubing
8A*	1	00797.17	Booster Heater Bypass Line
9	1	13669.45	Mixing Chamber SS
9A	2	03232.00	1/8" Male Plug

*8A replace 8 only on the machines without booster heater.

ITEM NO.	NO. REQ'D	P/N	DESCRIPTION
10	1	13306.17	Final Rinse Elbow Assy.
11	2	04306.00	Square Manifold Gasket
12	1	17550.10	Inlet Booster Heater Plumbing
13	1	17401.00	Final Rinse Manifold
14	1	13642.00	1/2" Brass Plug
15	1	00743.10	1/2" Tee F x F x F
16	4	00308.17	Rinse Arm SS End Plug
17	2	00304.29	Rinse Arm w/Bearing
18	4	00929.00	1/4-20 X 3/4 Bolt
19	8	00926.00	SS Washer 5/16"
20	4	00912.00	1/4"-20 Nylon Lock Nut
21	1	13607.00	Water Inlet
22	1	13607.20	Comp Fitting Sleeve
23	1	13607.30	Water Inlet L.T.
24	1	00760.00	5/8 Comp x 1/2 MIP Adapter

1.2.7. CMA-180 Door Handle Assembly

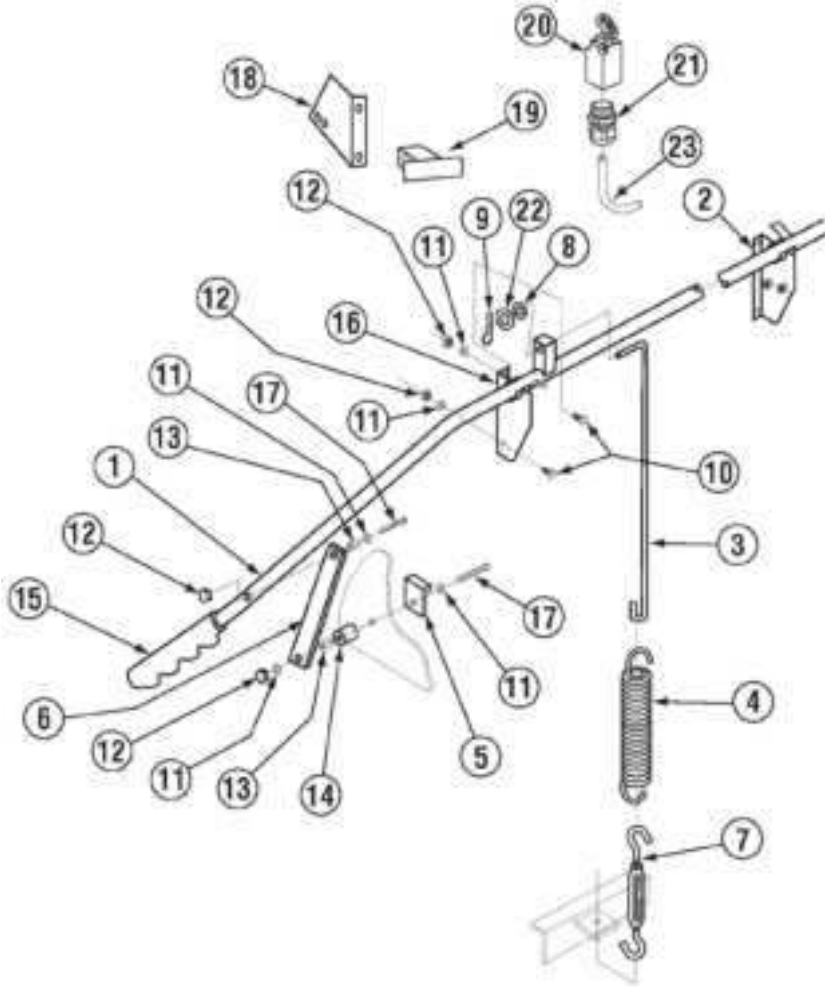

ITEM NO.	NO. REQ'D	P/N	DESCRIPTION
1	1	00613.32	Door Handle
2	1	01556.50	Right Door Handle Support
3	2	00603.07	Door Spring Extension Rod
4	2	00602.00	Door Spring
5	2	17552.00	Door Stop
6	2	01553.00	Door Handle Link
7	2	00606.50	Turn Buckle
8	2	00926.00	5/16" SS Washer
9	2	00900.00	Cotter Pin
10	4	00906.00	1/4"-20 x 1/2" Hex Head screw
11	8	00924.00	1/4" SS Washer
12	8	00912.00	1/4"-20" Nylon Insert Lock Nut

ITEM NO.	NO. REQ'D	P/N	DESCRIPTION
13	4	00610.00	Door Handle Spacer (Small)
14	4	00611.00	Door Handle Spacer (Large)
15	2	00607.04	Door Handle Cap
16	1	01555.50	Left Door Handle Support
17	2	00910.00	1/4"-20x1/2" Hex Head Bolt
18	1	00563.40	Door Switch Bracket (8-08)
19	1	00563.42	Door Switch Actuator (8-08)
20	1	00562.00	Door Roller Switch
21	1	00562.60	Connector Door Roller Switch
22	1	00605.30	Door Rod Spacer
23	1	00546.00	18 AWG Switch Cord

1.2.8. Corner Door Handle Assembly

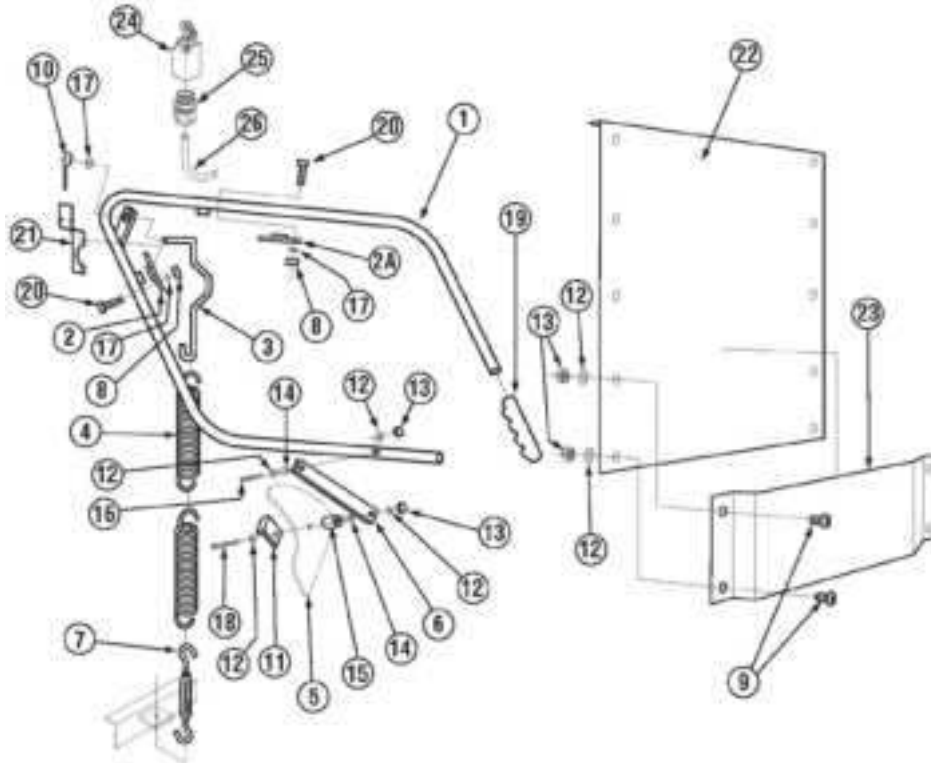

ITEM NO.	NO. REQ'D	P/N	DESCRIPTION
1	1	00613.04	Door Handle
2	1	00619.34	Door Handle Mntg Plate Lg
2A	1	00619.44	Door Handle Mntg Plate St
3	1	00603.04	Door Spring Extension
4	2	00602.00	Door Spring
5	2	17506.00	Door
6	2	01553.00	Door Handle Link
7	1	00606.50	Turn Buckle
8	9	00913.00	5/16"-18" Nut
9	10	00905.00	1/4"-20x1/2" Truss Head Bolt
10	1	00900.00	Cotter Pin
11	2	01552.00	Door Stop
12	16	00924.00	1/4" SS Washer
13	14	00912.00	1/4"-20 Nylon Lock Nut

ITEM NO.	NO. REQ'D	P/N	DESCRIPTION
14	4	00610.00	Door Handle Spacer (St)
15	4	00611.00	Door Handle Spacer (Lg)
16	2	00903.00	1/4"-20 x 1 3/4" Hex Head Bolt
17	9	00926.00	5/16" SS Washer
18	2	00910.00	1/4"-20x1/2" Hex Head Bolt
19	2	00607.04	Door Handle Cap
20	8	00920.00	5/16-18x3/4" Hex Head Bolt
21	1	00563.30	Limit Switch Door Bracket
22	1	17506.50	Door Panel Corner
23	1	17507.20	Air Gap Baffle Corner
24	1	00563.40	Door Switch Bracket (8-08)
25	1	00562.60	Connector Door Roller Switch
26	1	00546.00	18 AWG Switch Cord

1.2.9. Pump System Assembly

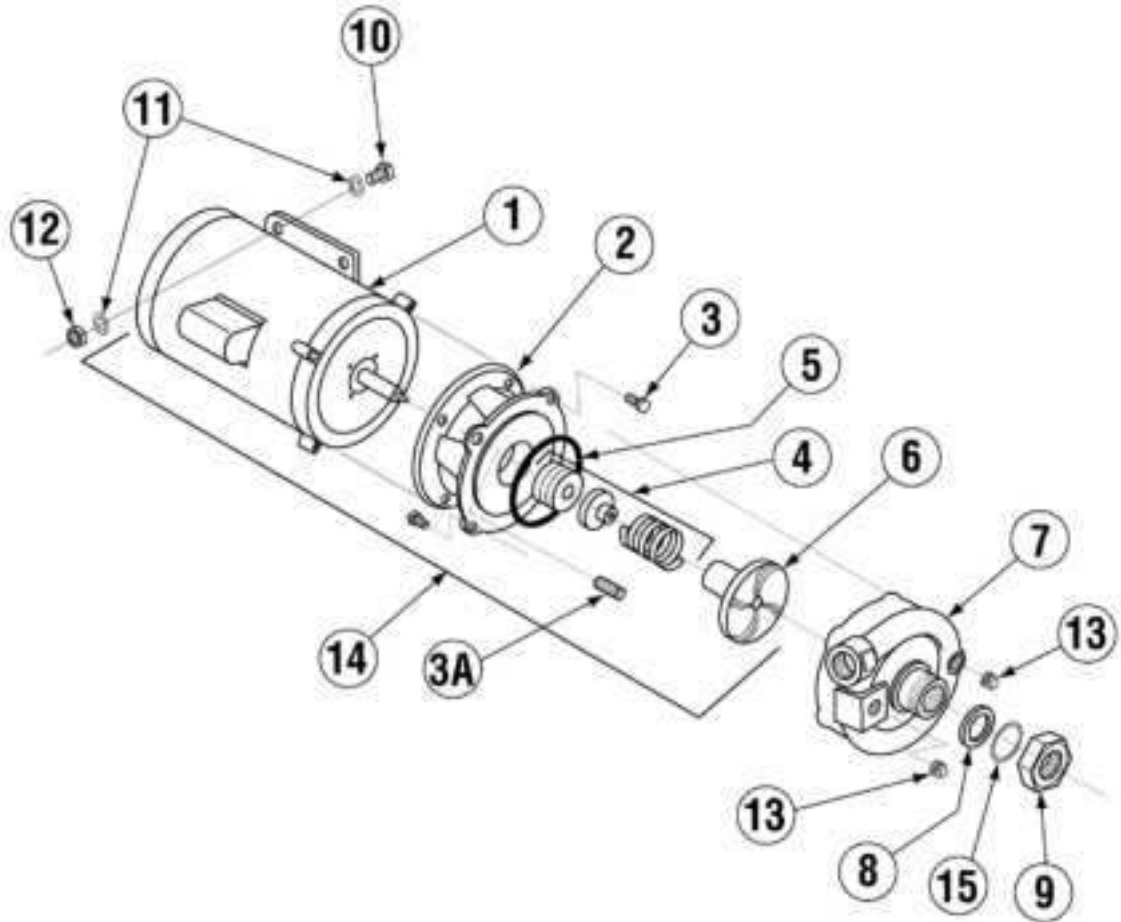

ITEM NO.	NO. REQ'D	P/N	DESCRIPTION
1	1	00201.00 00201.85	Pump Motor 1HP 1P 115/230V Pump Motor 1HP 3P 230/460V
2	1	04207.10	Small Pump Base
3	6	00921.00	3/8"-16 x 34" Hex Head Bolt
3A	2	00975.00	3/8-16 x 1 1/2" Stud
4	1	00206.30	Pump Seal Kit
5	1	03226.00	Pump "O" Ring
6	1	03222.10	Impeller SS
7	1	04207.20	Pump Cover

ITEM NO.	NO. REQ'D	P/N	DESCRIPTION
8	1	00208.40	Slip Joint Nut Gasket
9	1	00207.00	Compression Nut (2.5)
10	2	00906.00	1/4"-20 x 1/2" Hex Bolt
11	2	00924.00	1/4" SS Washer
12	2	00912.00	1/4"-20 Nylon Lock Nut
13	2	00238.00	3/8" Male Plug
*14	Assy.	00200.10	Pump Assy
15	1	00208.21	Slip Joint Nut Friction Ring

*P/N 00200.85 Includes Items 1,2,3,4,5 and 6

1.2.10. Old Wash Tank Heater (Square Flange)

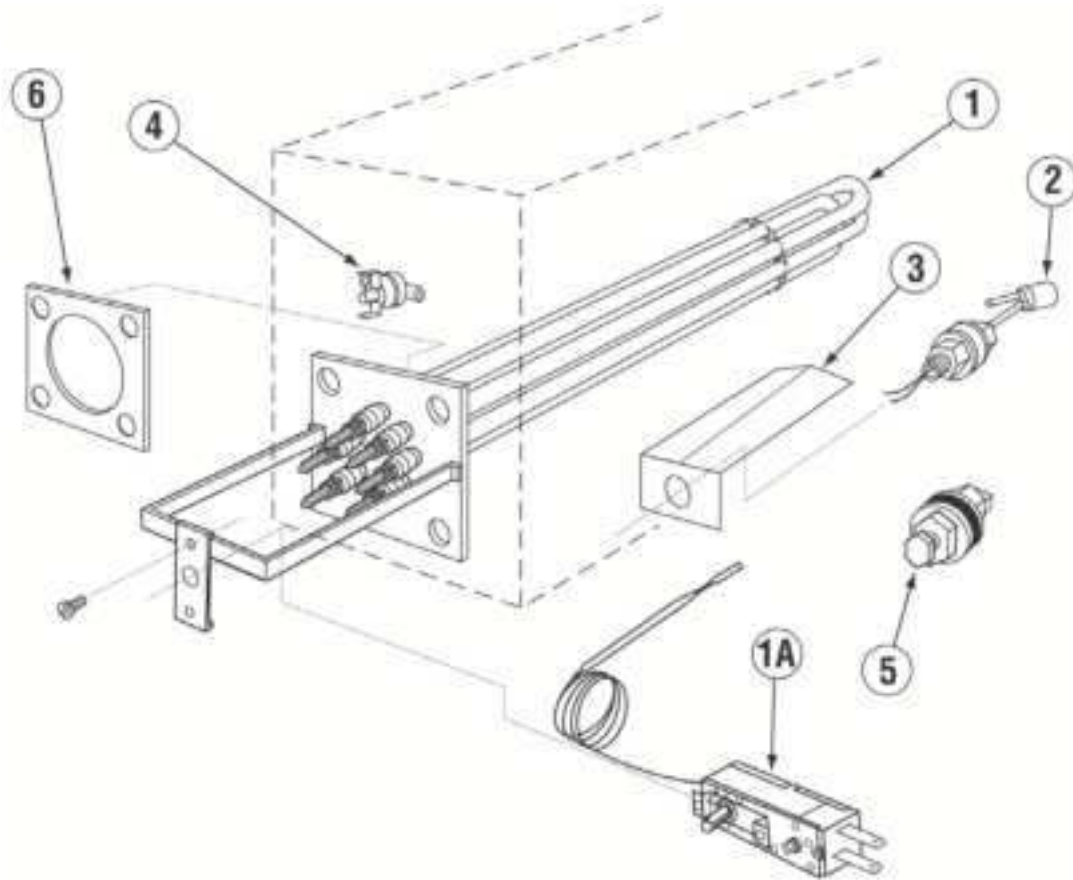

ITEM NO.	NO. REQ'D	P/N	DESCRIPTION
1	1	13417.65	Wash Tank Heater 5KW 3PH
	1	13417.64	Wash Tank Heater 7KW 3PH
1A	1	13417.92	Heater Thermostat
2	1	13463.14	Liquid Level Switch
3	1	13463.50	Liquid Level Switch Shield
4	1	17523.51	Hi-Limit Switch - Wash 250 Degrees
5	1	13477.20	7/8" Probe Hole Plug
6	1	13417.45	Wash Tank Heater Gasket

1.2.11. Old Booster Heater (Square Flange)

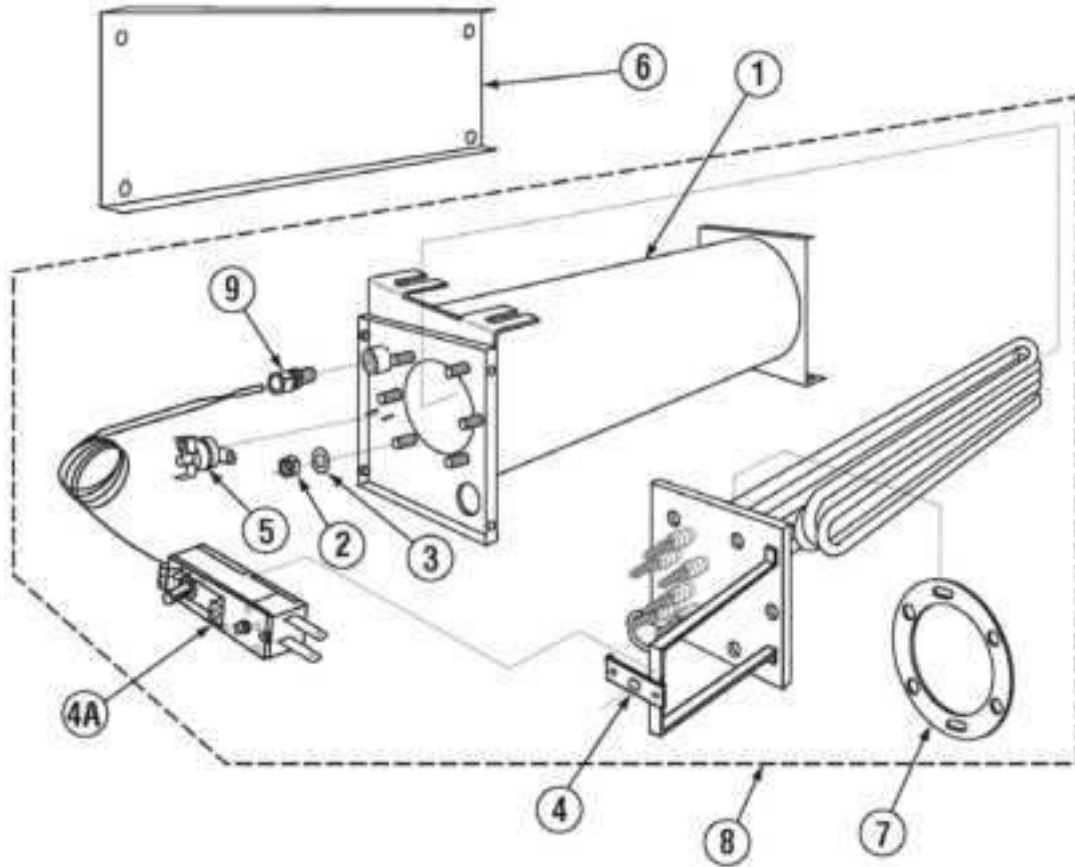

ITEM NO.	NO. REQ'D	P/N	DESCRIPTION
1	1	17550.00	Booster Tank
2	6	13805.00	Nylon Lock Nut 5/6"-18
3	6	00926.00	Washer SS 5/16"
**4	1	13417.67	Immersion Heater 12KW 3PH
4A	1	13417.92	Thermostat 12KW Heater
5	1	17523.51	Hi-Limit Switch-Booster 250 degrees
6	1	17520.00	Booster Heater Shield
7	1	13417.47	Booster Heater Gasket
8	1	17560.00	Complete Assembly
9	1	40116.00	1/4 Comp x 1/4 MIP Fitting
*For Straight Through Applications Only.			
**Includes Gasket #13417.47			

1.2.12. New Wash Tank Heater (Triangular Flange)

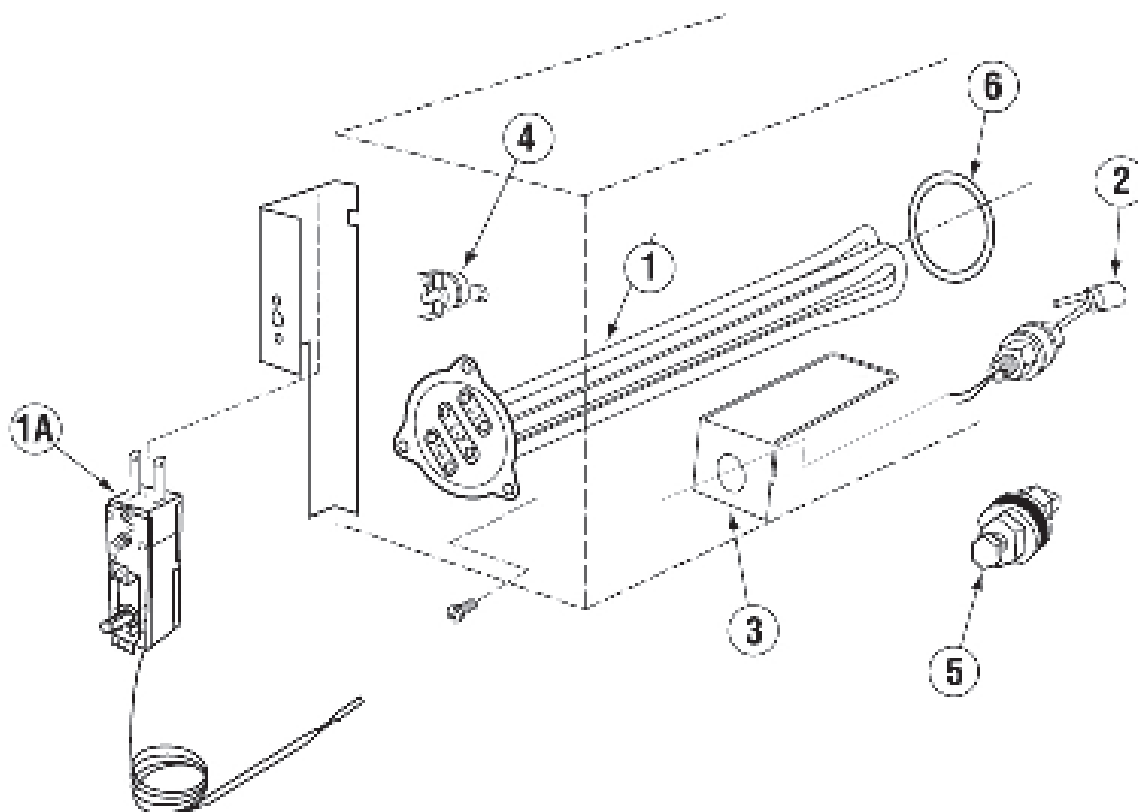

ITEM NO.	NO. REQ'D	P/N	DESCRIPTION
1	1	15518.00 13422.76	Heater 6kW 220V Triangular Flange Heater 6kW 480V Triangular Flange
1A	1	13417.92	Heater Thermostat
2	1	13463.14	Liquid Level Switch
3	1	13463.51	Liquid Level Switch Shield
4	1	17523.51	Hi-Limit Switch - Wash 250 Degrees
5	1	13477.20	7/8" Probe Hole Plug
6	1	15518.11	Gasket for Triangular Flange Heater

1.2.13. New Booster Heater (Triangular Flange)

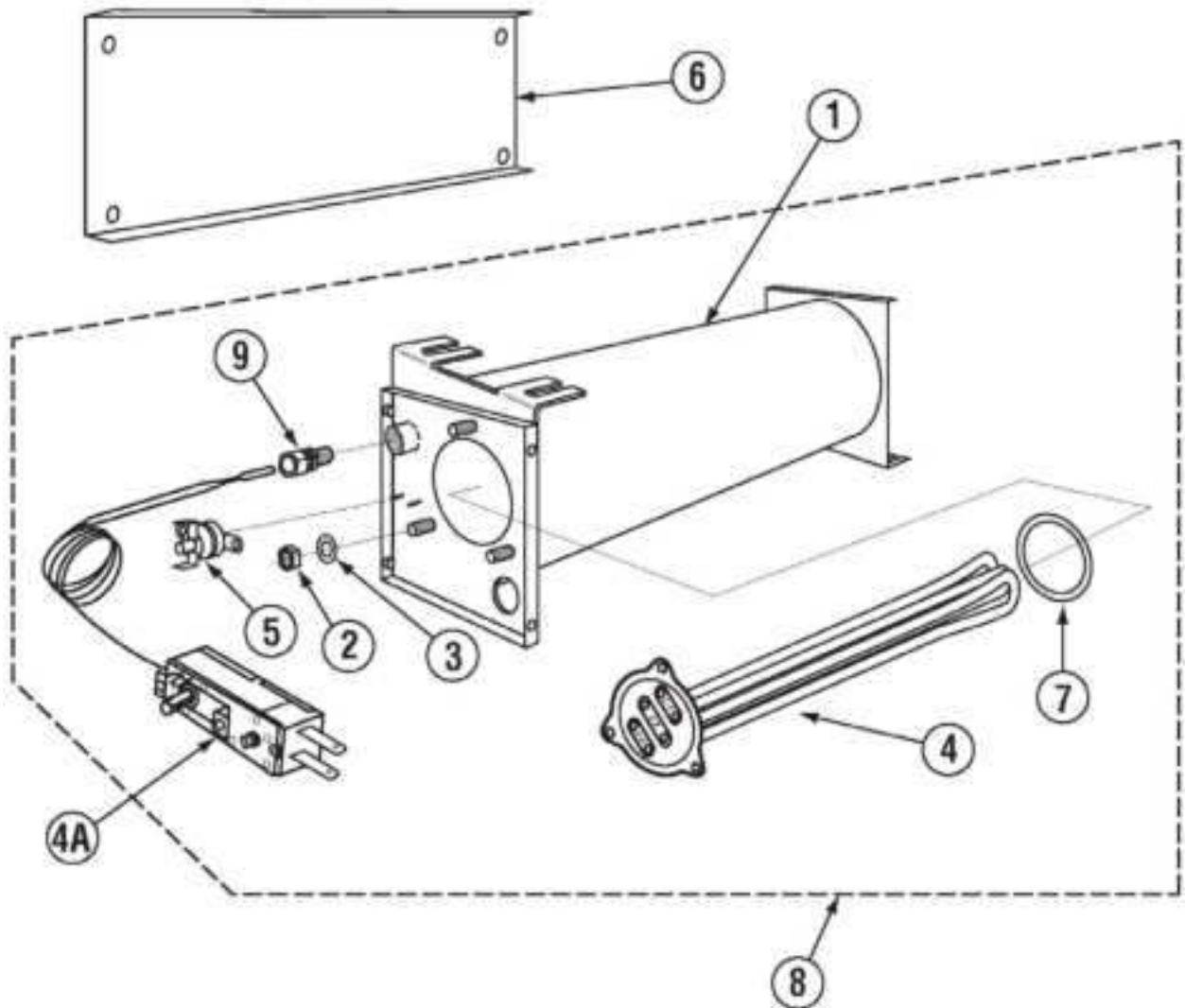

ITEM NO.	NO. REQ'D	P/N	DESCRIPTION
1	1	17550.20	Booster Tank
2	3	13805.00	Nylon Lock Nut 5/6"-18
3	3	00912.00	Washer SS 5/16"
4	1	13422.71 13422.75	240V 12KW Triangular Immersion Htr 480V 12 kW Triangular Immersion Htr
4A	1	13417.92	Thermostat 12KW Heater
5	1	17523.51	Hi-Limit Switch-Booster 250 degrees
6	1	17520.00	Booster Heater Shield
7	1	15518.11	Gasket for Triangular Flange Heater
8	1	17560.00	Complete Assembly
9	1	40116.00	1/4 Comp x 1/4 MIP Fitting

1.2.14. 480 Control Box Assembly

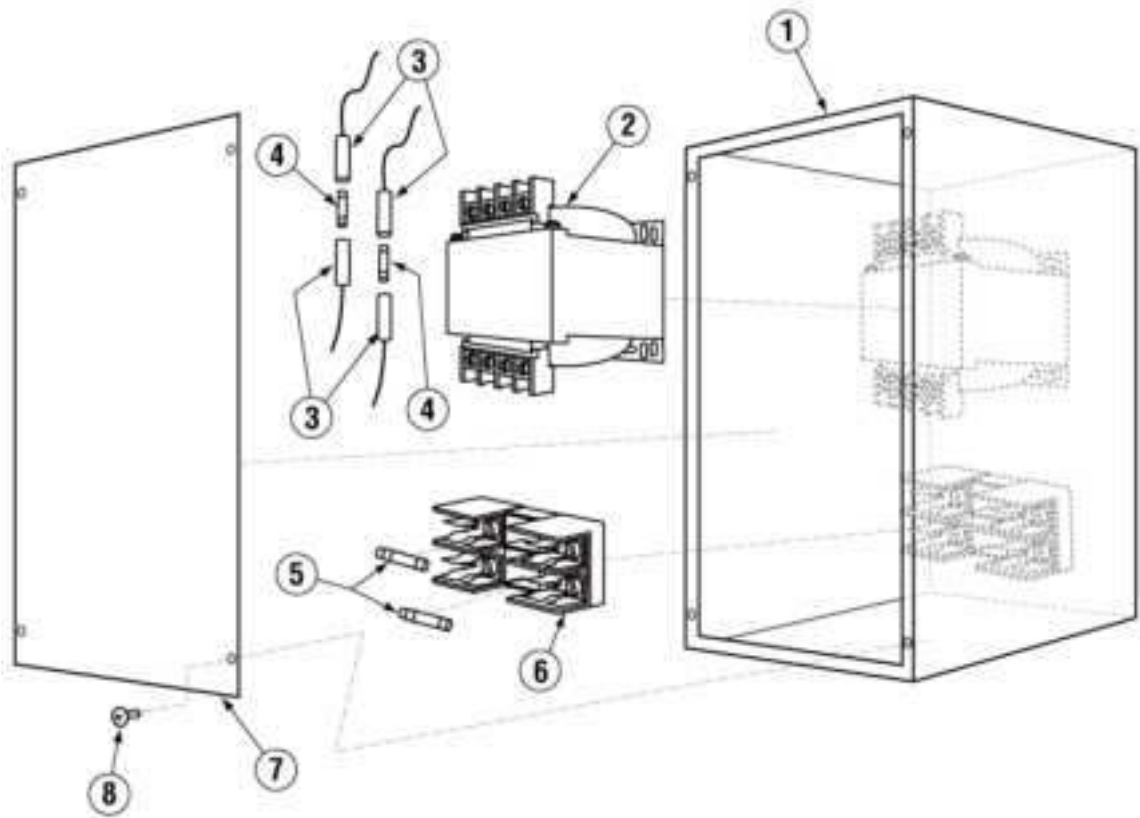

ITEM NO.	NO. REQ'D	P/N	DESCRIPTION
1	1	13905.13	Transformer Box
2	1	13423.82	Transformer 480V - 240V
3	2	13403.21	Fuse Holder - Inline
4	2	13403.40	Fuse 1.25 Amp 230V Slow Blow
5	2	13402.10	Fuse 1.50 Amp 600V Slow Blow
6	1	13420.10	Fuse Clip 2-Poll, Pressure Plate
7	1	13905.23	Transformer Box Lid
8	4	00940.50	10-32 3/8 Truss Head Screw

1.2.15. Control Box Assembly

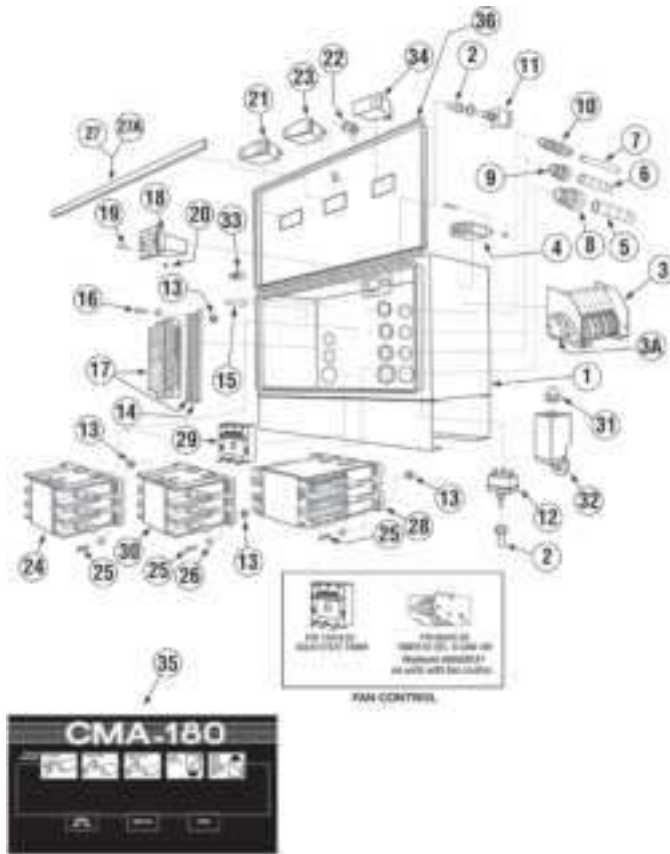

ITEM NO.	NO. REQ'D	P/N	DESCRIPTION
1	1	17503.39	CMA-180 Control Box Body
2	2	00470.10	Toggle Switch Rubber Boot
3	1*	00409.81	Timer CMA-180
3A	1	00501.17	Timer Motor
4	1(2**)	00631.05	Ice Cube Relay 220V
5	6 Ft.	00400.85	Conduit 3/4" Sealite
6	6 Ft.	00400.10	Conduit 1/2" Sealite
7	2 Ft.	00400.00	Conduit 3/8" Sealite
8	1	00401.85	St-3/4" Straight Connector
9	1	00401.10	St-1/2" Straight Connector
10	1	00401.00	St-3/8" Straight Connector
11	1	00475.70	Delimer Switch DPDT 15A
12	1	03470.00	Toggle Switch Momentary (Screw Terminal)
13	8	03801.00	Nylon Lock Nut 10-32
14	1	17400.06	Mounting Din Rail
15	1	13403.26	Fuse 3A/250V Slow Blow
16	2	00941.00	Pan Head Screw 10 -32 x 5/8"
17	1	17400.17	Terminal Block Assembly
17A	2	17400.04	30 Amp Terminal Block-Red
17B	3	17400.03	60 Amp Terminal Block-Black
17C	4	17400.02	85 Amp Terminal Block-Natural
17D	2	17400.08	30 Amp Terminal Block-Blue
17E	2	17400.09	30 Amp Terminal Block-Natural

* Includes timer motor p/n 501.17 and microswitch 411.00

ITEM NO.	NO. REQ'D	P/N	DESCRIPTION
17F	1	17400.07	60 Amp Terminal Block-Green
18	1	03408.55	Counter Face Mount 220V
19	4	00911.00	Pan Head Screw 8-32 x 1/2"
20	4	00927.00	Lock Nut 8-32
21	1	00421.90	Power Switch
22	1	00449.50	Keyless Lock
23	1	00421.89	Rocker Switch Auto Fill
24	1	00404.85	Motor Contactor 208/240V 20A
		13003.55	Motor Contactor 30 Amp
25	6	13825.00	Pan Head Screw 8-31 x 1"
26	6	04806.00	#10 Brass Washer
27	2	17503.17	Control Box Sponge Long
27A	2	17503.18	Control Box Sponge Short
28	1**	13003.17	Contactor 60A 3 Pole 220V
29	1	13418.60	Dip Switch Timer 230V
30	1	13003.55	Heater Contactor 30 Amp
31	1	00562.60	Door Roller Switch Connector
32	1	00562.00	Door Roller Switch
33	1	13426.50	Ground Block
34	1	00421.78	Illuminated Plug
35	1	006231.19	Control Panel Label CMA-180
36	1	17503.29	Control Box Lid

** Only for the machines with booster heater

1.2.15. Control Box Assembly January 2021

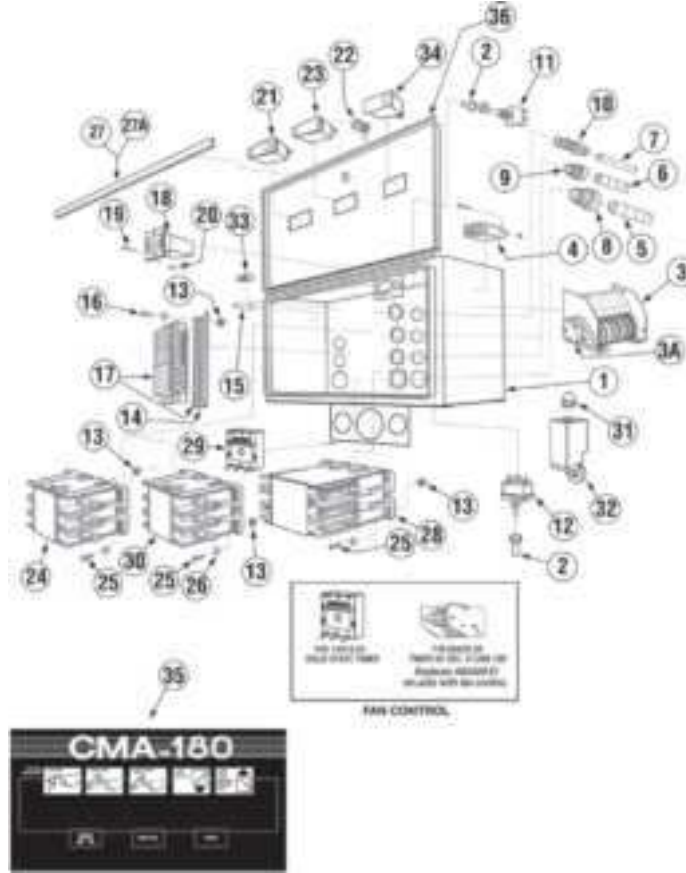

ITEM NO.	NO. REQ'D	P/N	DESCRIPTION
1	1	17503.39	CMA-180 Control Box Body
2	2	00470.10	Toggle Switch Rubber Boot
3	1*	00409.81	Timer CMA-180
3A	1	00501.17	Timer Motor
4	1(2*)	00631.05	Ice Cube Relay 220V
5	6 Ft.	00400.85	Conduit 3/4" Sealite
6	6 Ft.	00400.10	Conduit 1/2" Sealite
7	2 Ft.	00400.00	Conduit 3/8" Sealite
8	1	00401.85	St-3/4" Straight Connector
9	1	00401.10	St-1/2" Straight Connector
10	1	00401.00	St-3/8" Straight Connector
11	1	00475.70	Delimer Switch DPDT 15A
12	1	03470.00	Toggle Switch Momentary (Screw Terminal)
13	8	03801.00	Nylon Lock Nut 10-32
14	1	17400.06	Mountain Din Rail
15	1	13403.26	Fuse 3A/250V Slow Blow
16	2	00941.00	Pan Head Screw 10 -32 x 5/8"
17	1	17400.17	Terminal Block Assembly
17A	2	17400.04	30 Amp Terminal Block-Red
17B	3	17400.03	60 Amp Terminal Block-Black
17C	4	17400.02	85 Amp Terminal Block-Natural
17D	2	17400.08	30 Amp Terminal Block-Blue
17E	2	17400.09	30 Amp Terminal Block-Natural

* Includes timer motor p/n 501.17 and microswitch 411.00

ITEM NO.	NO. REQ'D	P/N	DESCRIPTION
17F	1	17400.07	60 Amp Terminal Block-Green
18	1	03408.55	Counter Face Mount 220V
19	4	00911.00	Pan Head Screw 8-32 x 1/2"
20	4	00927.00	Lock Nut 8-32
21	1	00421.90	Power Switch
22	1	00449.50	Keyless Lock
23	1	00421.89	Rocker Switch Auto Fill
24	1	00404.85	Motor Contactor 208/240V 20A
		13003.55	Motor Contactor 30 Amp
25	6	13825.00	Pan Head Screw 8-31 x 1"
26	6	04806.00	#10 Brass Washer
27	2	17503.17	Control Box Sponge Long
27A	2	17503.18	Control Box Sponge Short
28	1**	13003.17	Contactor 60A 3 Pole 220V
29	1	13418.60	Dip Switch Timer 230V
30	1	13003.55	Heater Contactor 30 Amp
31	1	00562.60	Door Roller Switch Connector
32	1	00562.00	Door Roller Switch
33	1	13426.50	Ground Block
34	1	00421.78	Illuminated Plug
35	1	006231.19	Control Panel Label CMA-180
36	1	17503.29	Control Box Lid

** Only for the machines with booster heater

1.2.16. Unique Parts For CMA-180TS

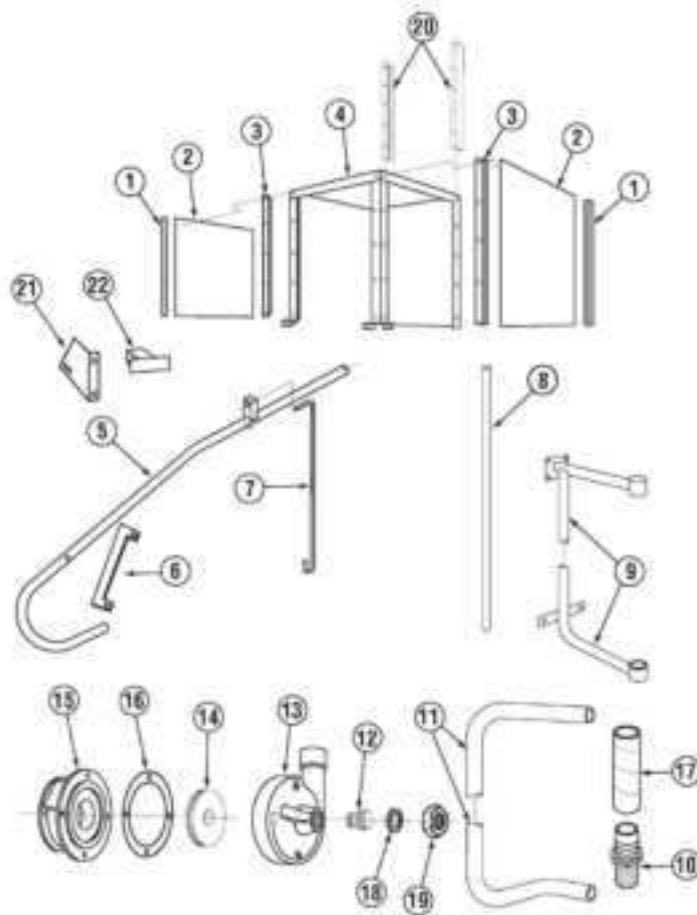

ITEM NO.	NO. REQ'D	P/N	DESCRIPTION
1	6	00636.27	Door Guide Material
2	3	17506.20	Scullery Door
3	6	17554.20	Scullery Door Guide
4	1	17530.20	Scullery Wrapper
5	1	00613.27	Door Handle Straight
6	2	01553.22	Door Handle Link Straight
7	2	00603.53	Door Spring Extension Rod
8	2	05007.27	Booster Water Line
9	1	17401.20	Final Rinse Manifold
10	1	50302.10	1" MPT x 1" Barb Brass
11	1	00303.27	Manifold
12	1	00212.50	1-1/2"x1-1/4"Adapter

ITEM NO.	NO. REQ'D	P/N	DESCRIPTION
13	1	00204.00	Pump Cover Large
14	1	00203.05	Impeller 4-1/2"
15	1	00202.00	Pump Base
16	1	00205.00	Pump Gasket
17	1	03108.60	Transfer Hose 1" Reinf.
18	1	00208.40	Slip Joint Nut O Ring
19	1	00207.00	Slip Joint Nut 1 1/2 x 1/4
20	1	17570.00	Wrap Support Brkt-R
	1	17570.10	Wrap Support Brkt-L
21	1	00563.40	Door Switch Bracket (8-08)
22	1	00563.43	Door Switch Actuator CMA-180T (1-10)
23	2	00602.20	Door Spring - Heavy Duty

1.2.17. Unique Parts For CMA-180TC

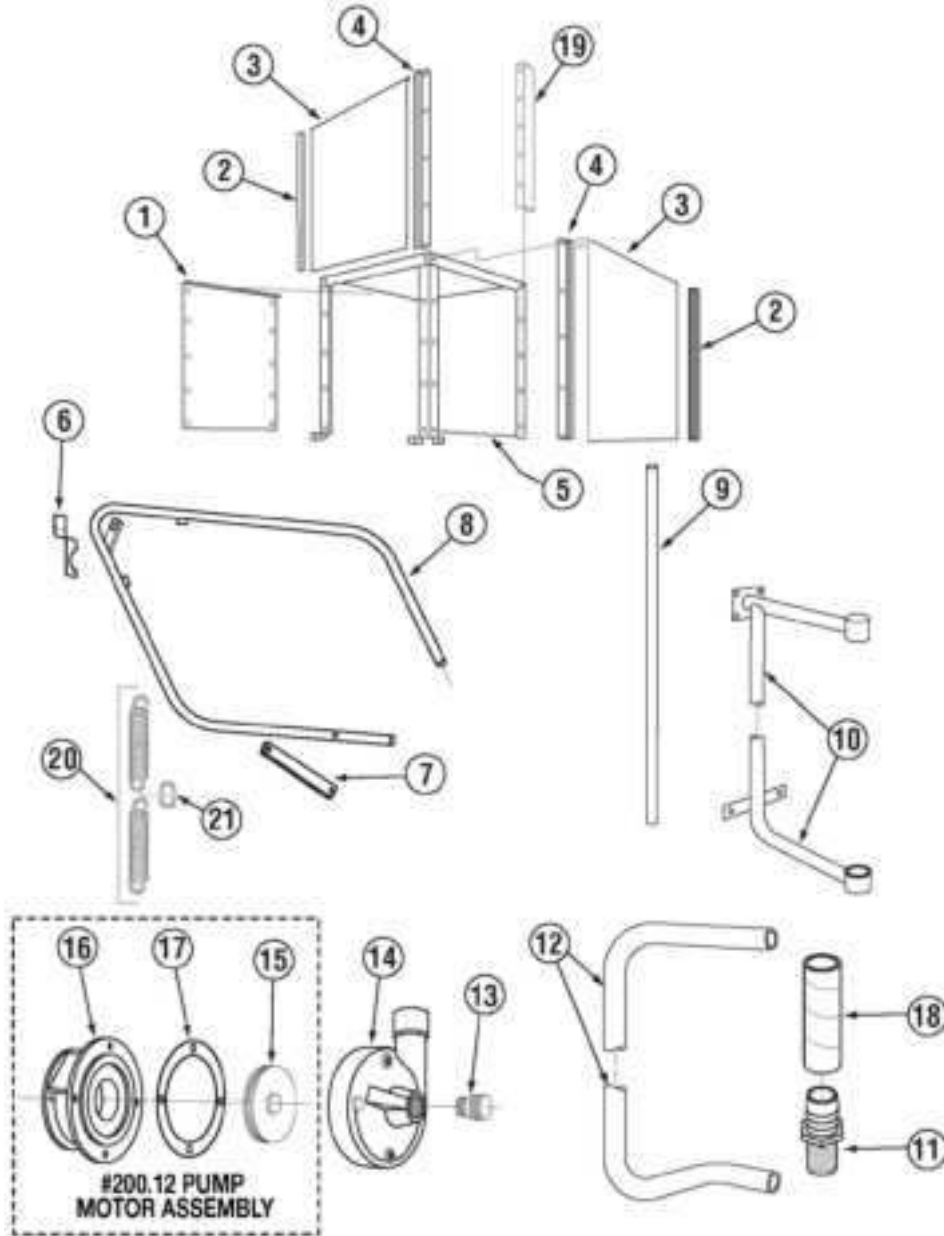

ITEM NO.	NO. REQ'D	P/N	DESCRIPTION
1	1	17506.20	Door Panel Scullery Corner
2	6	00636.27	Door Guide Material
3	2	17506.20	Scullery Door
4	4	17554.20	Scullery Door Guide
5	1	17530.20	Scullery Wrapper
6	1	00563.60	Limit Switch Door Bracket
7	2	01553.20	Door Handle Link Corner
8	1	00613.34	Door Handle Corner
9	2	05007.27	Booster Water Line
10	1	17401.20	Final Rinse Manifold
11	1	50302.10	1" MPT x 1" Barb Brass

ITEM NO.	NO. REQ'D	P/N	DESCRIPTION
12	1	00303.27	Manifold
13	1	00212.50	1-1/2"x1-1/4"Adapter
14	1	00204.00	Pump Cover Large
15	1	00203.05	Impeller 4-1/2"
16	1	00202.00	Pump Base
17	1	00205.00	Pump Gasket
18	1	03108.60	Transfer Hose 1" Reinf.
19	1	17570.00	Wrap Support Brkt-R
20	2	00602.20	Door Spring - Heavy Duty
21	1	00604.27	Door Extension Link

1.2.18. Unique Parts for CMA-180T Split Door

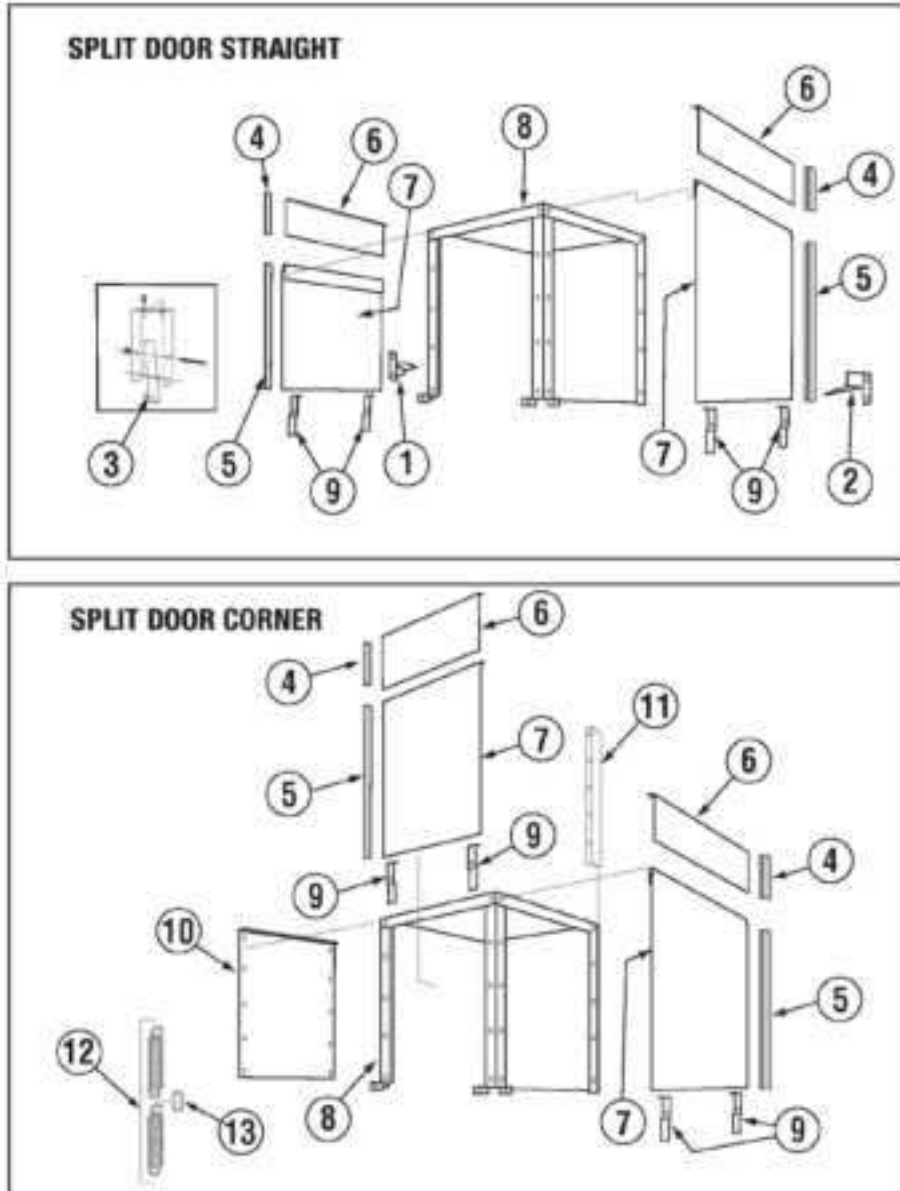

ITEM NO.	NO. STR/COR	P/N	DESCRIPTION
1	1/0	17506.23	Door Safety Brkt. Left
2	1/0	17506.24	Door Safety Brkt. Right
3	1/0	13701.22	Open Door Latch
4	6/4	00636.43	EZ Glide Door Gide 8.5"
5	6/4	00636.42	EZ Glide Door Gide 29.75"
6	3/2	17506.42	Small Door
7	3/2	17506.34	Large Door

ITEM NO.	NO. STR/COR	P/N	DESCRIPTION
8	1/1	17530.22	Wrapper
9	6/4	17552.22	Door Stop
10	0/1	17530.23	Corner Panel Wrap
11	1/1	17570.00	Wrap Support Brkt-R
	1/0	17570.10	Wrap Support Brkt-L
12	2	00602.20	Door Spring - Heavy Duty
13	1	00604.27	Door Extension Link

2. Power Switch Bulb Replacement Instructions

NOTE: For Old Style Machines ONLY -- Manufactured prior to May 2002

TO REPLACE BULB

1. Using a 5mm-screw driver dismount the light module from the actuator as shown in illustration 1 & 2.
2. Replace the burnt bulb with a new one P/N 17421.10 by twisting the bulb 90 degrees.
3. Mount the light module by snapping it onto the actuator as shown in illustration 3.

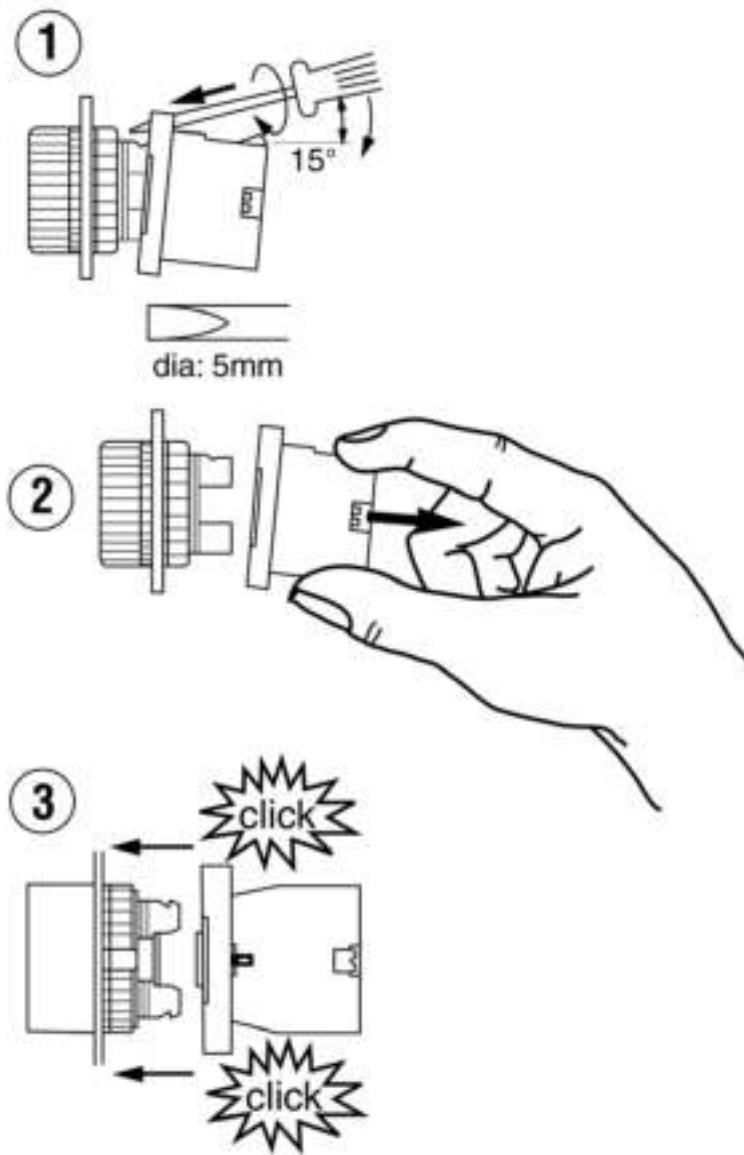

3. 180 Conversion Kit – Corner to Straight #00617.18

INSTRUCTIONS:

1. Open dishwasher doors to their highest position so that there is little spring resistance on the door handle. Remove hardware holding the door handle to the door linkage. Save all the washers and spacers. With the door handle in "UP" position, lift spring and remove from extension rod. Remove the nut attaching the eyebolt and save all hardware.
2. To remove the door handle, simply unscrew the four bolts holding the door handle mounting plates and slide the complete assembly up and off of the cabinet. Use the bolts, nuts and washers to plug the holes in the back of the cabinet.
3. Remove door panel & hardware from left side of machine, and install door guides from kit. Remove front door and relocate to left side of machine. The service door will be used to seal off this side of machine. Remove bolt located on top right hand corner of the wrapper and use it to mount service door latch bracket. Relocate tray track guide to front service door side of tray track.
4. Using provided nuts, bolts and washers; mount the left and right door handle supports on the back of the cabinet. Insert the eyebolts into the brackets on the back of the dishwasher stand and screw the nuts on just enough to hold them in place. Hook both door springs and door spring extension rods on to the door handle and secure them with the washers and cotter pins. Then simply rest the door handle on the door handle supports. (You may have to lift the door handle to reach the handle supports.)
5. Swing the door handle downwards to reach the door linkages; and using the two provided bolts and existing washers and spacers, attach the door linkages to the door handle. Adjust the tension in the spring by tightening the nuts under the eyebolt bracket so that the doors can slide up and down freely. Mount the provided door handle grips on the ends of the door handle.
6. Eyebolt adjustment nuts should be adjusted to the point the doors begin to lift from a closed position. Both eyebolts should be adjusted the same. SEE "Illustration #1" for the proper location of all door handle hardware for CMA 180-S.
7. "Illustration #2" shows CMA 180-S and CMA 180-C door handle assembly.

ILLUSTRATION #1

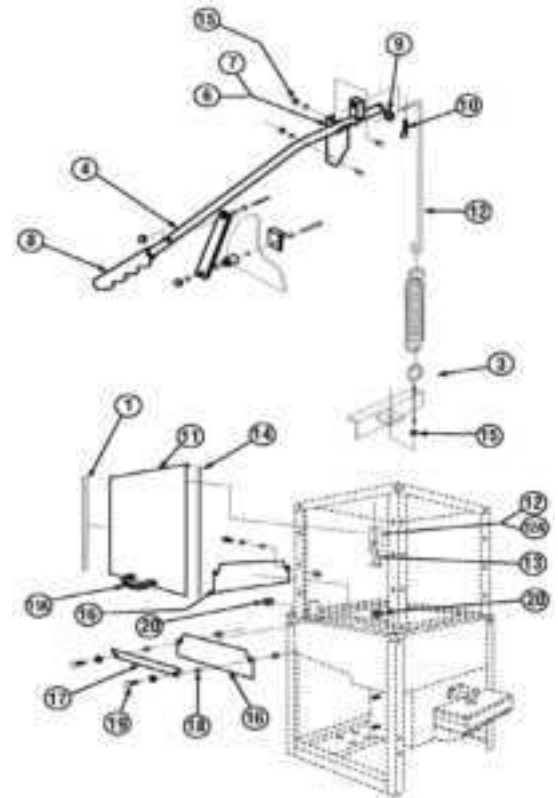
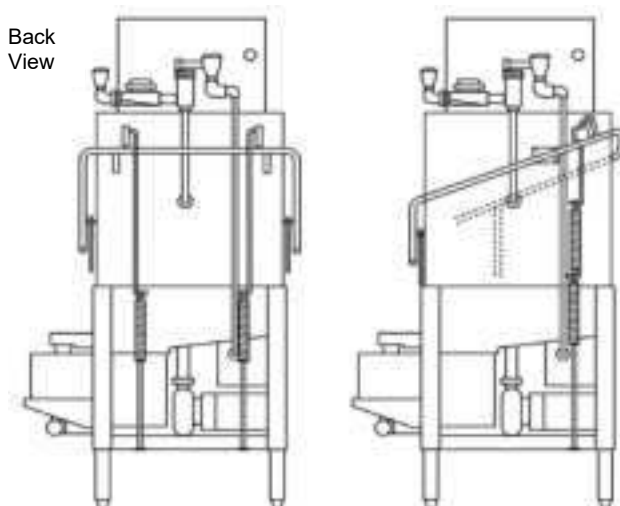

ILLUSTRATION #2



ITEM NO.	NO. REQ'D	P/N	DESCRIPTION
1	2	00636.17	EZ Glide Door Guide
2	2	00603.07	Door Spring Extension Rod
3	1	00606.00	5/16"-18 x 7" Eyebolt
4	1	00613.17	Door Handle
5	2	00913.00	5/16"-18 SS Nut
6	1	01555.50	L.H. Door Handle Support
7	1	01556.50	R.H. Door Handle Support
8	2	00607.04	Door Handle Grip
9	4	00924.00	¼" SS Washer
10	2	00900.00	Cotter Pin
11	1	17506.00	Service Door
11A	1	00535.30	Door Handle
12	1	13915.00	Door Latch Bracket
12A	1	13915.06	Latch Bracket with Nut
13	1	13701.00	Open Door Latch
14	2	17554.00	Door Glide
15	4	00912.00	¼" 20 Nylon Lock Nut
16	2	17506.60	Door Splashguard-Straight
17	1	17506.65	Service Door Splashguard-S
18	4	00610.00	Spacer Small
19	4	00962.00	¼"-20 x 1 SS Hex Head Bolt
20	2	1222.50	Tank Plug

4. 180 Conversion Kit – Straight to Corner #00617.17

INSTRUCTIONS:

1. Open dishmachine door to its highest position so that there is little spring resistance on the door handle. Remove hardware that holds the door handle to the door linkage. Save all the washers and spacers. Swing the door handle towards the back of the dishmachine and dismount it from the door handle support brackets. Remove the two nuts attaching the eyebolts and save the door springs.
2. Remove the two (2) door-handle support brackets on the back of the cabinet and plug the four holes with original hardware. Remove front door and replace with left door. Remove door guides on left side of machine and attaché item No. 9 door panel-cover. The left door will now be at the front of the machine. Remove and relocate service door splashguard to left side of machine. Remove door latch for service door. The door latch is not needed on the CMA 180-C.
3. With left door facing the front, door panel on the left, and service door splashguard in place, we are now ready to install the door handle.
4. Using provided door handle, door handle mounting plates, 5/16" bolts, nuts and washers; install the door handle as shown in "Illustration #1". Match the mounting plate holes to the cabinet holes and insert all bolts to ensure that the door handle and mounting plates are aligned. Then secure the mounting plate with nuts and washers.

Note: You may install one of the mounting plates first, then insert the door handle pivot post in and mount the other mounting plate last.

5. Attach the provided extension rod to the back of the door handle. Attach one eyebolt to the frame with existing hardware, along with two springs together. Pivot the door handle, positioning handle straight up. You may now connect loop of 2nd spring to the door extension rod. Pull handles forward and down and attach to the door links.
6. Adjust the nut on the eyebolt until the doors begin to lift then back off two turns. See "Illustration #2" for proper location of all door handle hardware included on CMA 180C.
7. "Illustration #3" shows CMA 180-S and CMA 180-C "Door Handle Assembly".

ILLUSTRATION #2

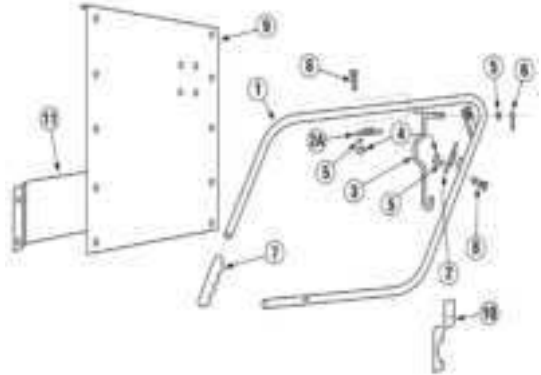

ITEM NO.	NO. REQ'D	P/N	DESCRIPTION
1	1	00613.04	Door Handle
2	1	00619.34	Door Hdl. Mtng. Plate-Long
2A	1	00619.44	Door Hdl. Mtng. Plate-Short
3	1	00603.04	Door Spring Extension
4	9	00913.00	5/16" - 18" Nut
5	9	00926.00	5/16" SS washer
6	1	00900.00	Cotter Pin
7	2	00607.04	Door Handle Grip
8	8	00920.00	5/16"-18 x 3/4" Hex Head Bolt
9	1	17506.50	Door Panel-Cover
10	1	00563.20	Roller Switch Bracket
11	1	17507.10	Air Gap Baffle CMA 180C

ILLUSTRATION #1 Back View

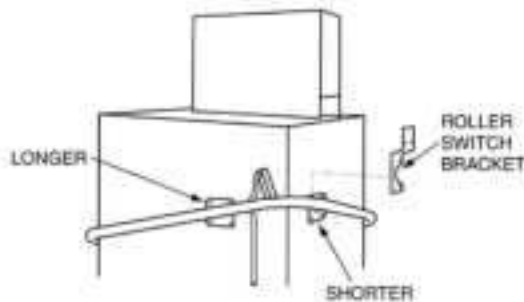

Note: Door handle mounting plates come in two sizes. Longer is mounted on back-right side.

ILLUSTRATION #3 Back View

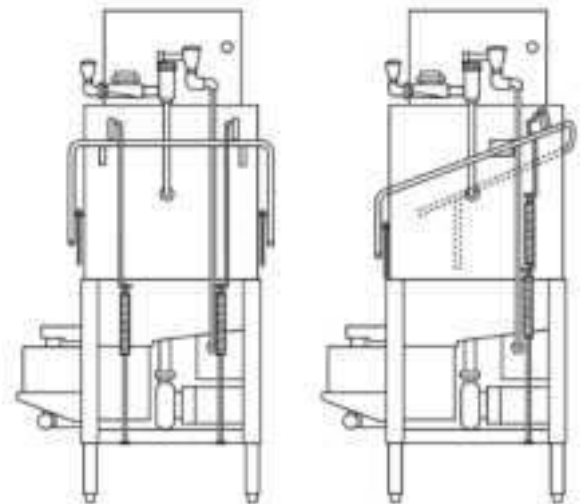

Parts Manual

Drain Water Tempering Valve Assembly (Effective 03-2023)

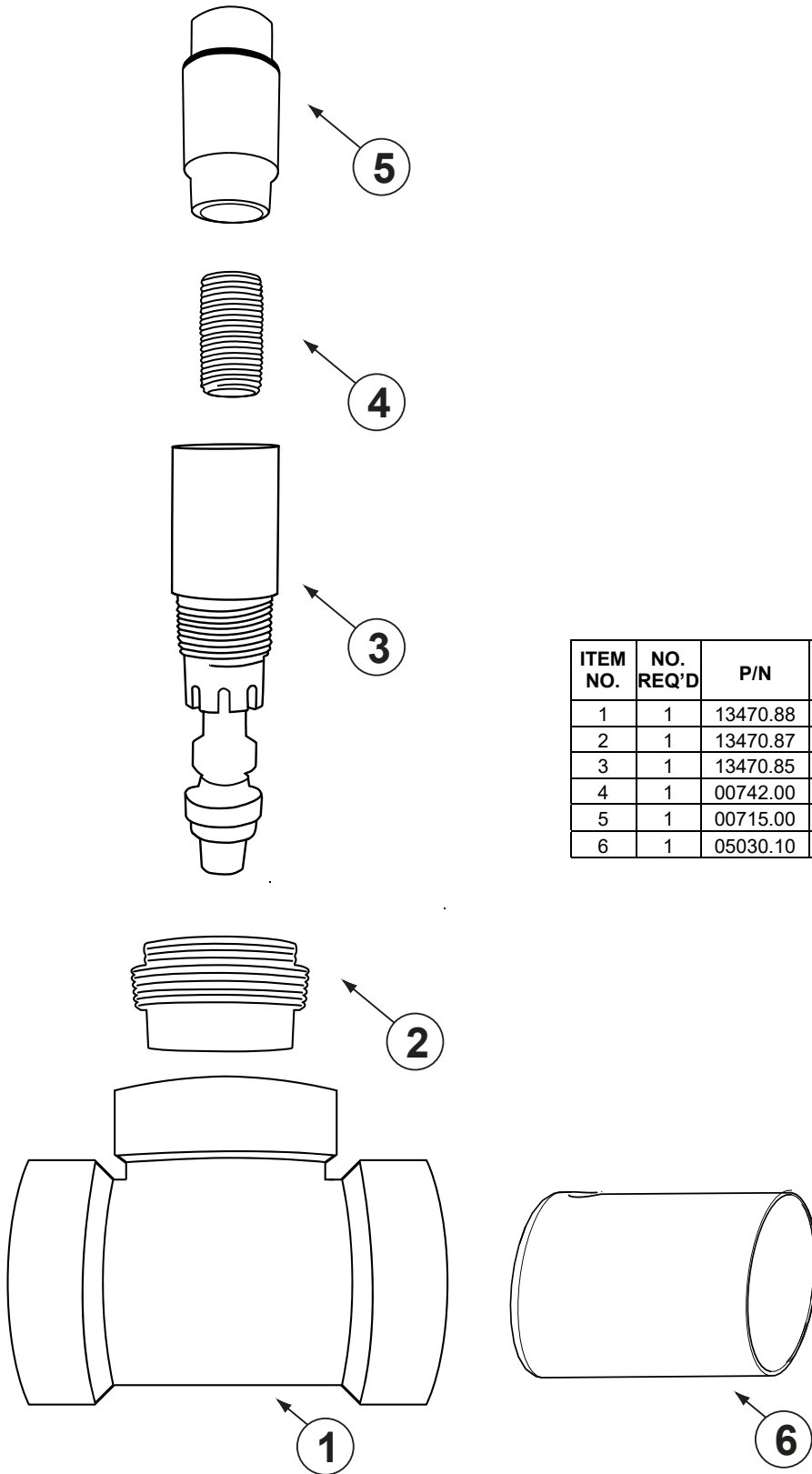

ITEM NO.	NO. REQ'D	P/N	DESCRIPTION
1	1	13470.88	2 ABS Tee S x S x MIP
2	1	13470.87	DTV Adapter 2" X 3/4"
3	1	13470.85	Drain Water Tempering Valve
4	1	00742.00	Nipple Brass 1/2 x 1-1/2
5	1	00715.00	1/2 Ball Check Valve
6	1	05030.10	2 x 3 ABS Tubing