



Connect Tech Inc.
Embedded Computing Experts

www.connecttech.com

USERS GUIDE

Xtreme/10G Managed Ethernet Switch/Router Users Guide

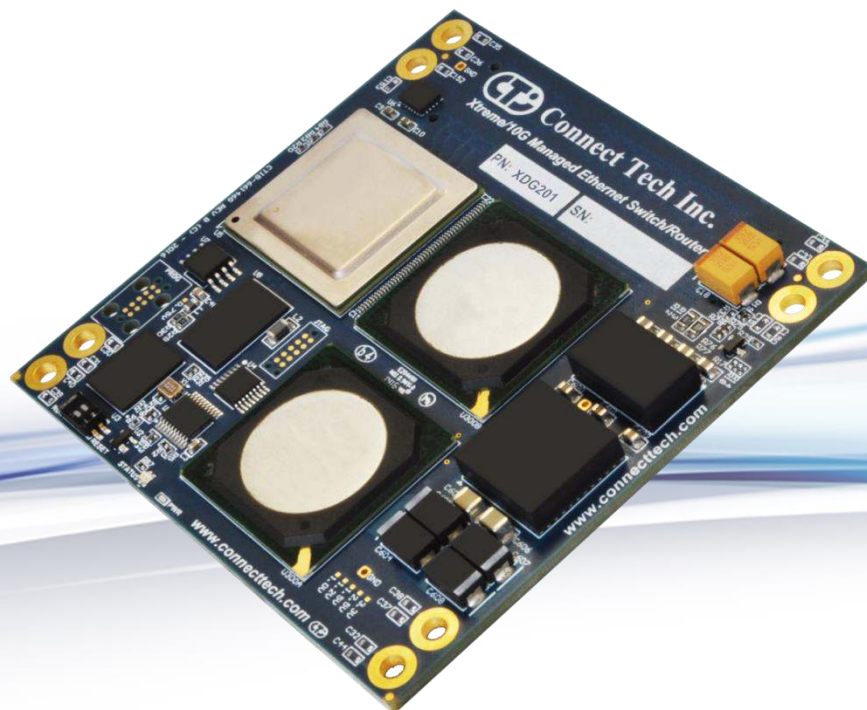

Connect Tech Inc.
42 Arrow Road
Guelph, Ontario
N1K 1S6
www.connecttech.com

Tel: **519-836-1291**
Toll: **800-426-8979** (North America only)
Fax: 519-836-4878
Email: sales@connecttech.com
support@connecttech.com

CTIM-00472 Revision 0.08 2019/07/09

Table of Contents

Table of Contents	2
Preface	4
Disclaimer	4
Customer Support Overview	4
Contact Information	4
Limited Product Warranty	5
Copyright Notice	5
Trademark Acknowledgment	5
ESD Warning	6
Revision History	6
Introduction	7
Product Features and Specifications	7
Product Overview	8
Block Diagram	8
Connector Locations	9
Connector Summary.....	10
Switch Summary & Locations	10
Detailed Feature Description	11
Main Board-to-Board Connector.....	11
Pinout Table.....	12
Board-to-Board Reference Design Package	13
SFP and SFP+ CU Transceiver Support	13
Switch Details	14
DIP Switch Details (S1)	14
Typical Installation	14
On-Board Indicator LED's	14
CLI Management Interface	15
CLI Access via External Serial Port.....	15
CLI Basics	15
Complete CLI and Protocol Configuration Reference Guide.....	15
Web Management Interface	16
Accessing the Web Management Interface	16
Web Management Interface Overview.....	17
Complete Web Protocol Configuration Reference Guide	17
Breakout Boards	18
XBG301 – Embedded Carrier	18
XBG301 – Embedded Carrier Specifications	18
XBG301 +XDG201 + XHG201 – Dimensioned Drawing	19
XBG301 +XDG201 + XHG201 – Assembly Drawing	20
Thermal Details	21



XDG201 Thermal Parameters	21
XHG201 – Conduction Cooled Heatplate	21
Current Consumption Details	22
Mechanical Details.....	23
3D Model	23
2D Drawing (Top Side).....	23
2D Drawing (Bottom Side)	24

Preface

Disclaimer

The information contained within this user's guide, including but not limited to any product specification, is subject to change without notice.

Connect Tech assumes no liability for any damages incurred directly or indirectly from any technical or typographical errors or omissions contained herein or for discrepancies between the product and the user's guide.

Customer Support Overview

If you experience difficulties after reading the manual and/or using the product, contact the Connect Tech reseller from which you purchased the product. In most cases the reseller can help you with product installation and difficulties.

In the event that the reseller is unable to resolve your problem, our highly qualified support staff can assist you. Our support section is available 24 hours a day, 7 days a week on our website at: <http://connecttech.com/support/resource-center/>. See the contact information section below for more information on how to contact us directly. Our technical support is always free.

Contact Information

Mail/Courier

Connect Tech Inc.
Technical Support
42 Arrow Road
Guelph, Ontario
Canada N1K 1S6

Email/Internet

sales@connecttech.com
support@connecttech.com
www.connecttech.com

Note:

Please go to the [Connect Tech Resource Center](#) for product manuals, installation guides, device drivers, BSPs and technical tips. Submit your [technical support](#) questions to our support engineers.

Telephone/Facsimile

Technical Support representatives are ready to answer your call Monday through Friday, from 8:30 a.m. to 5:00 p.m. Eastern Standard Time. Our numbers for calls are:

Toll Free: 800-426-8979 (North America only)

Telephone: 519-836-1291 (Live assistance available 8:30 a.m. to 5:00 p.m. EST, Monday to Friday)

Facsimile: 519-836-4878 (on-line 24 hours)



Limited Product Warranty

Connect Tech Inc. provides a one year Warranty for the Xtreme/10G Managed Ethernet Switch/Router. Should this product, in Connect Tech Inc.'s opinion, fail to be in good working order during the warranty period, Connect Tech Inc. will, at its option, repair or replace this product at no charge, provided that the product has not been subjected to abuse, misuse, accident, disaster or non-Connect Tech Inc. authorized modification or repair.

You may obtain warranty service by delivering this product to an authorized Connect Tech Inc. business partner or to Connect Tech Inc. along with proof of purchase. Product returned to Connect Tech Inc. must be pre-authorized by Connect Tech Inc. with an RMA (Return Material Authorization) number marked on the outside of the package and sent prepaid, insured and packaged for safe shipment. Connect Tech Inc. will return this product by prepaid ground shipment service.

The Connect Tech Inc. Limited Warranty is only valid over the serviceable life of the product. This is defined as the period during which all components are available. Should the product prove to be irreparable, Connect Tech Inc. reserves the right to substitute an equivalent product if available or to retract the Warranty if no replacement is available.

The above warranty is the only warranty authorized by Connect Tech Inc. Under no circumstances will Connect Tech Inc. be liable in any way for any damages, including any lost profits, lost savings or other incidental or consequential damages arising out of the use of, or inability to use, such product.

Copyright Notice

The information contained in this document is subject to change without notice. Connect Tech Inc. shall not be liable for errors contained herein or for incidental consequential damages in connection with the furnishing, performance, or use of this material. This document contains proprietary information that is protected by copyright. All rights are reserved. No part of this document may be photocopied, reproduced, or translated to another language without the prior written consent of Connect Tech, Inc.

Copyright © 2017 by Connect Tech, Inc.

Trademark Acknowledgment

Connect Tech, Inc. acknowledges all trademarks, registered trademarks and/or copyrights referred to in this document as the property of their respective owners. Not listing all possible trademarks or copyright acknowledgments does not constitute a lack of acknowledgment to the rightful owners of the trademarks and copyrights mentioned in this document.

ESD Warning



Electronic components and circuits are sensitive to ElectroStatic Discharge (ESD). When handling any circuit board assemblies including Connect Tech carrier assemblies, it is recommended that ESD safety precautions be observed. ESD safe best practices include, but are not limited to:

- Leaving circuit boards in their antistatic packaging until they are ready to be installed.
- Using a grounded wrist strap when handling circuit boards, at a minimum you should touch a grounded metal object to dissipate any static charge that may be present on you.
- Only handling circuit boards in ESD safe areas, which may include ESD floor and table mats, wrist strap stations and ESD safe lab coats.
- Avoiding handling circuit boards in carpeted areas.
- Try to handle the board by the edges, avoiding contact with components.

Revision History

Revision	Date	Changes
0.00	2016-06-15	Never Released
0.01	2016-08-18	Initial Release
0.02	2017-05-30	Updated B2B Connector Pinout Table
0.03	2017-07-25	<ul style="list-style-type: none"> - Corrected pin definitions of D69 and D68 in the B2B Pinout Table - Added additional information on breakout board options and their corresponding reference design package.
0.04	2017-07-27	<ul style="list-style-type: none"> - Vitesse Firmware version change, default IP now set to 10.10.10.1
0.05	2017-08-04	Added heatplate drawing link, removed drawing from doc
0.06	2017-09-11	<ul style="list-style-type: none"> - Fixed XDG201 3D Model Link - Added KDB entry on SFP+ CU Transceiver Compatibility
0.07	2018-05-15	Edited KDB link on SFP+ CU Transceiver Compatibility
0.08	2019-07-09	Corrected port speeds

Introduction

Connect Tech's Xtreme/10G Managed Ethernet Switch (XDG201) provides high density, high port count Layer 2 switching and Layer 3 routing with 10G uplinks. A total of 36 switchable ports, with 4 x 10G, 8 x 1G (SGMII) and 24 x 1G (Copper 10/100/1000Mbps) Ports in an extremely small form factor 85mm x 85mm. The devices target managed Layer 2 and Layer 3 equipment in SMB, SME, and industrial applications where high port count 1G switching with 10G aggregation/uplinks are required.

The XDG201 is a **Network Switching Module**. This module is of a proprietary form factor and contains a board-to-board connector that allows it to be integrated into an off the shelf carrier like the [XBG301](#) or other custom/application specific carrier.

Product Features and Specifications

Feature	Description
Ethernet Switch Engine	Vitesse VSC7448 Carrier Grade Ethernet Switch Chipset
Ports	36 Total Switching Ports 4 x 10G (SFI) Ports 8 x 1G (SGMII) Ports 24 x 1G (Copper 10/100/1000Mbps) Ports Note: All ports are exposed over the proprietary module board-to-board connector; physical interface must be implemented on carrier board.
Memories	4Gb DDR3 SDRAM 128Mb Serial NOR Flash
I/O Connectors	High-Density 440-pin Board-to-Board Connector
Layer 2 & Layer 3 Forwarding	IEEE802.1Q switch with 4K VLANs and 32K MAC table entries Push/pop up to 3VLAN tags on ingress and egress RSTP and MSTP support Fully non-blocking wire-speed switching performance for all frame sizes IPv4/IPv6 unicast and multicast Layer 2 switching with up to 32K groups and 1K port masks IPv4/IPv6 unicast and multicast Layer 3 forwarding (routing) with reverse path forwarding (RPF) support IGMPv2, IGMPv3, MLDv1, and MLDv2 support Link aggregation (IEEE 802.3ad) Independent and shared VLAN learning (IVL, SVL) Jumbo frame support
Quality of Service	Four megabytes of integrated shared packet memory Eight QoS classes with a pool of up to 32K queues TCAM-based classification with pattern matching against Layer 2 through Layer 4 Information Dual-rate policers selected by VCAP IS2, eight single-rate priority policers per port, and four single-rate port policers for each port Flexible 4K ingress QoS mappings and 8K egress QoS mappings for VLAN tags and DSCP values Up to 4K egress VLAN tag operations Audio/video bridging (AVB) with support for time-synchronized, low-latency and video streaming services Priority-based flow control (PFC) (IEEE 802.1Qbb)
Security	Vitesse Content Aware Processor (VCAP™) packet filtering engine using ACLs for ingress and egress packet inspection Storm controllers for flooded broadcast, flooded multicast, and flooded unicast traffic Per-port, per-address registration for copying/redirecting/discarding 32 VCAP single-rate policers
Maximum Bandwidth	80Gbps
Layer 2 Switching Parameters	Packet Buffer: 32Mb MAC Table Size: 32k Layer 2 Multicast Port Masks: 1k Super VCAP blocks: 8 VCAP CLM entries: 4k VCAP LPM entries: 4k/1k (IPv4/IPv6) VCAP IS2 entries: 4k/1k (IPv4/IPv6)



Layer 3 Routing Parameters	Router Legs: 128 IP unicast routes/hosts: 4k/1k (IPv4/IPv6) Next -hop/ ARP table entries: 2k IP multicast groups: 2k/512 Multicast router leg masks: 1k ECMPs: 16
Management Access	Web Interface CLI via RS-232 Software API SNMP
Input Voltage	+4V to 14V Input Range (External Connector)
Power Consumption	24W Max / 14W Idle
Dimensions	85mm x 85mm
Weight	TBD
MTBF	TBD
Operating Temp	-40°C to +85°C (chipset rated to +125°C thermals)
Warranty and Support	1 Year Warranty and Free Technical Support

Product Overview

Block Diagram

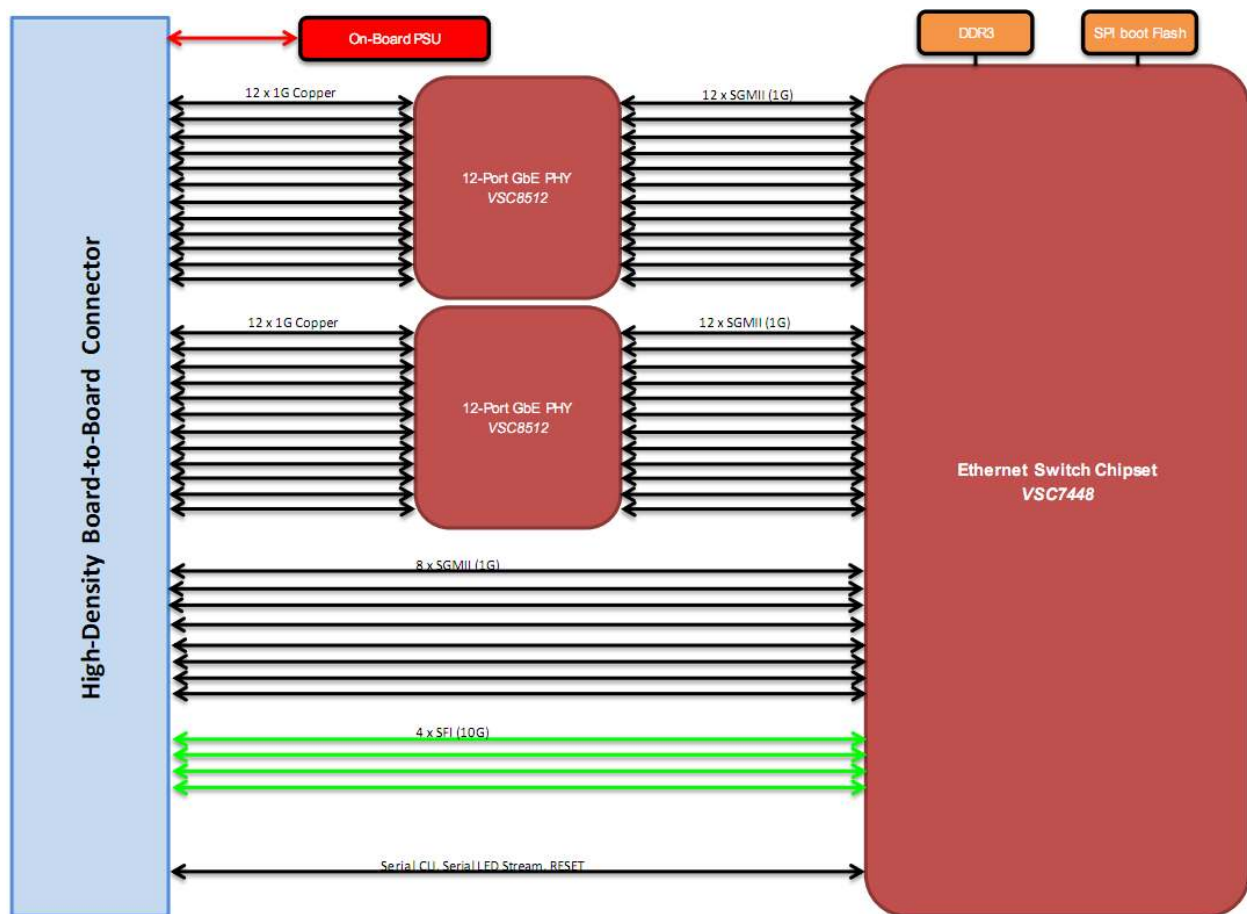

Connector Locations

Top Side

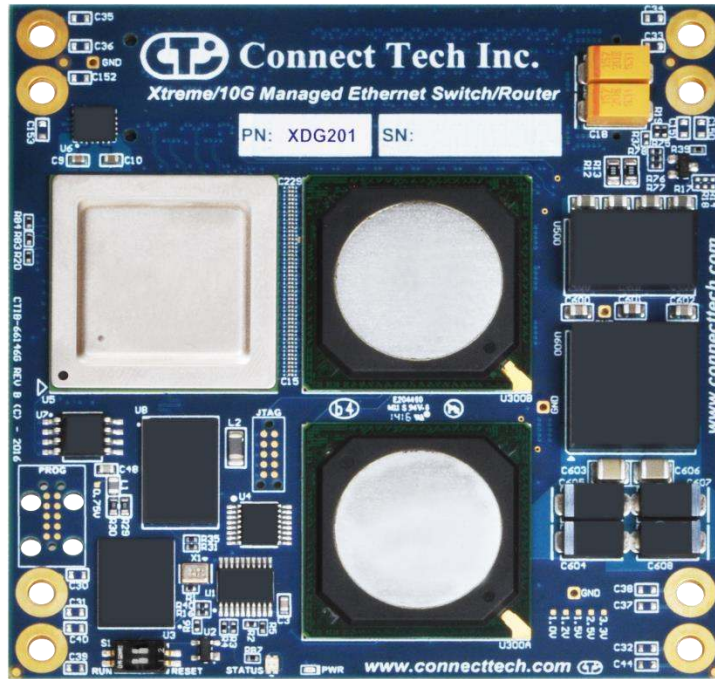

Config Switch (S1)

Bottom Side

Main Board-to-Board (P1)

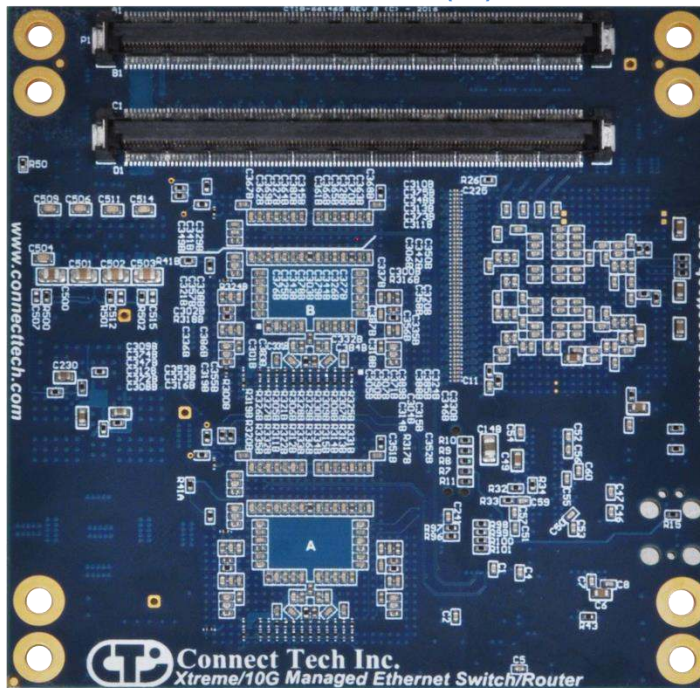

Connector Summary

Designator	Connector	Description
P1	Main Board-to-Board	Primary Signal and Power Breakout Connector

Switch Summary & Locations

Designator	Function	Description
S1	Config Switch	Used to Put Switch in to Manual Reset Mode

Detailed Feature Description

Main Board-to-Board Connector

The Main Board-to-Board connector carries:

- Input power from the carrier to the module
- Power control and reset signals
- **24x 1G** copper pairs, for termination to RJ-45s on carrier board
- **4x 10G** for connection to SFP+ on the carrier board
- **8x 1G** for connection to SFP on the carrier board
- LED management signal chain
- SFP detection and control chain

LED and SFP management signals chains required specific circuitry on the carrier; see the reference design for details.

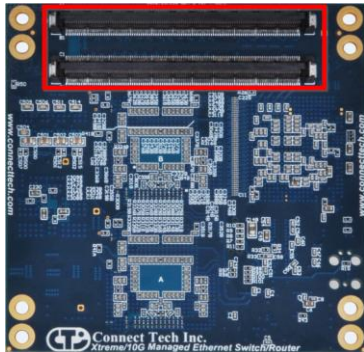
Function	Primary Signal and Power Breakout	
Location	P1	
XDG201 Module Connector	<p>Primary Part Manufacturer: TE Connectivity Part Number: 3-1827231-6</p> <p>Cross Reference 1 Manufacturer: FCI Part Number: TBD</p>	
Carrier Board Mating Connector	<p>Primary Part Manufacturer: TE Connectivity Part Number: 3-5353652-6</p> <p>Cross Reference 1 Manufacturer: FCI Part Number: TBD</p>	



Pinout Table

GND	A110	B110	GND	GND	C110	D110	GND
1GF-P7-RXD P	A109	B109	1GF-P7-TXD P	GND	C109	D109	GND
1GF-P7-RXD N	A108	B108	1GF-P7-TXD N	10G-P3-RXD P	C108	D108	10G-P3-TXD P
GND	A107	B107	GND	10G-P3-RXD N	C107	D107	10G-P3-TXD N
1GF-P6-RXD P	A105	B105	1GF-P6-TXD P	GND	C106	D106	GND
1GF-P6-RXD N	A105	B105	1GF-P6-TXD N	GND	C105	D105	GND
GND	A104	B104	GND	10G-P2-RXD P	C104	D104	10G-P2-TXD P
1GF-P5-RXD P	A103	B103	1GF-P5-TXD P	10G-P2-RXD N	C103	D103	10G-P2-TXD N
1GF-P5-RXD N	A102	B102	1GF-P5-TXD N	GND	C102	D102	GND
GND	A101	B101	GND	GND	C101	D101	GND
GND	A100	B100	GND	GND	C100	D100	GND
1GF-P4-RXD P	A99	B99	1GF-P4-TXD P	GND	C99	D99	GND
1GF-P4-RXD N	A98	B98	1GF-P4-TXD N	10G-P1-RXD P	C98	D98	10G-P1-TXD P
GND	A97	B97	GND	10G-P1-RXD N	C97	D97	10G-P1-TXD N
1GF-P3-RXD P	A96	B96	1GF-P3-TXD P	GND	C96	D96	GND
1GF-P3-RXD N	A95	B95	1GF-P3-TXD N	GND	C95	D95	GND
GND	A94	B94	GND	10G-P0-RXD P	C94	D94	10G-P0-TXD P
1GF-P2-RXD P	A93	B93	1GF-P2-TXD P	10G-P0-RXD N	C93	D93	10G-P0-TXD N
1GF-P2-RXD N	A92	B92	1GF-P2-TXD N	GND	C92	D92	GND
GND	A91	B91	GND	GND	C91	D91	GND
GND	A90	B90	GND	GND	C90	D90	GND
1GF-P1-RXD P	A89	B89	1GF-P1-TXD P	SGPIO2_DI	C89	D89	I2C_SDA
1GF-P1-RXD N	A88	B88	1GF-P1-TXD N	SGPIO2_LD	C88	D88	I2C_SCL
GND	A87	B87	GND	SGPIO2_DO	C87	D87	MUX_SEL2
1GF-P0-RXD P	A86	B86	1GF-P0-TXD P	SGPIO2_CLK	C86	D86	MUX_SEL1
1GF-P0-RXD N	A85	B85	1GF-P0-TXD N	SFP+D_SCL	C85	D85	MUX_SEL0
GND	A84	B84	GND	SFP+C_SCL	C84	D84	SLED1_DO
RESET#_IN	A83	B83	UART_TX	SFP+B_SCL	C83	D83	SLED1_CLK
RESET#_OUT	A82	B82	UART_RX	SFP+A_SCL	C82	D82	SLEDO_DO
PWROK_IN	A81	B81	PWROK_OUT	PUSHBUTTON#	C81	D81	SLEDO_CLK
GND	A80	B80	GND	GND	C80	D80	GND
EE_WP#	A79	B79	Reserved	Reserved	C79	D79	Reserved
MAND_WP#	A78	B78	Reserved	Reserved	C78	D78	Reserved
Reserved	A77	B77	Reserved	Reserved	C77	D77	Reserved
Reserved	A76	B76	Reserved	Reserved	C76	D76	Reserved
Reserved	A75	B75	Reserved	Reserved	C75	D75	Reserved
Reserved	A74	B74	Reserved	Reserved	C74	D74	Reserved
Reserved	A73	B73	Reserved	Reserved	C73	D73	Reserved
Reserved	A72	B72	Reserved	Reserved	C72	D72	Reserved
Reserved	A71	B71	Reserved	Reserved	C71	D71	Reserved
GND	A70	B70	GND	GND	C70	D70	GND
1GC-P15-D3 P	A69	B69	1GC-P13-D3 P	1GC-P3-D3 P	C69	D69	1GC-P0-D3 P
1GC-P15-D3 N	A68	B68	1GC-P13-D3 N	1GC-P3-D3 N	C68	D68	1GC-P0-D3 N
1GC-P15-D2 P	A67	B67	1GC-P13-D2 P	1GC-P3-D2 P	C67	D67	1GC-P0-D2 P
1GC-P15-D2 N	A66	B66	1GC-P13-D2 N	1GC-P3-D2 N	C66	D66	1GC-P0-D2 N
1GC-P15-D1 P	A65	B65	1GC-P13-D1 P	1GC-P3-D1 P	C65	D65	1GC-P0-D1 P
1GC-P15-D1 N	A64	B64	1GC-P13-D1 N	1GC-P3-D1 N	C64	D64	1GC-P0-D1 N
1GC-P15-D0 P	A63	B63	1GC-P13-D0 P	1GC-P3-D0 P	C63	D63	1GC-P0-D0 P
1GC-P15-D0 N	A62	B62	1GC-P13-D0 N	1GC-P3-D0 N	C62	D62	1GC-P0-D0 N
GND	A61	B61	GND	GND	C61	D61	GND
GND	A60	B60	GND	GND	C60	D60	GND
1GC-P16-D3 P	A59	B59	1GC-P13-D3 P	1GC-P4-D3 P	C59	D59	1GC-P1-D3 P
1GC-P16-D3 N	A58	B58	1GC-P13-D3 N	1GC-P4-D3 N	C58	D58	1GC-P1-D3 N
1GC-P16-D2 P	A57	B57	1GC-P13-D2 P	1GC-P4-D2 P	C57	D57	1GC-P1-D2 P
1GC-P16-D2 N	A56	B56	1GC-P13-D2 N	1GC-P4-D2 N	C56	D56	1GC-P1-D2 N
1GC-P16-D1 P	A55	B55	1GC-P13-D1 P	1GC-P4-D1 P	C55	D55	1GC-P1-D1 P
1GC-P16-D1 N	A54	B54	1GC-P13-D1 N	1GC-P4-D1 N	C54	D54	1GC-P1-D1 N
1GC-P16-D0 P	A53	B53	1GC-P13-D0 P	1GC-P4-D0 P	C53	D53	1GC-P1-D0 P
1GC-P16-D0 N	A52	B52	1GC-P13-D0 N	1GC-P4-D0 N	C52	D52	1GC-P1-D0 N
GND	A51	B51	GND	GND	C51	D51	GND
1GC-P17-D3 P	A50	B50	1GC-P14-D3 P	1GC-P5-D3 P	C50	D50	1GC-P2-D3 P
1GC-P17-D3 N	A49	B49	1GC-P14-D3 N	1GC-P5-D3 N	C49	D49	1GC-P2-D3 N
1GC-P17-D2 P	A48	B48	1GC-P14-D2 P	1GC-P5-D2 P	C48	D48	1GC-P2-D2 P
1GC-P17-D2 N	A47	B47	1GC-P14-D2 N	1GC-P5-D2 N	C47	D47	1GC-P2-D2 N
1GC-P17-D1 P	A46	B46	1GC-P14-D1 P	1GC-P5-D1 P	C46	D46	1GC-P2-D1 P
1GC-P17-D1 N	A45	B45	1GC-P14-D1 N	1GC-P5-D1 N	C45	D45	1GC-P2-D1 N
1GC-P17-D0 P	A44	B44	1GC-P14-D0 P	1GC-P5-D0 P	C44	D44	1GC-P2-D0 P
1GC-P17-D0 N	A43	B43	1GC-P14-D0 N	1GC-P5-D0 N	C43	D43	1GC-P2-D0 N
GND	A42	B42	GND	GND	C42	D42	GND
GND	A41	B41	GND	GND	C41	D41	GND
1GC-P18-D3 P	A40	B40	1GC-P21-D3 P	1GC-P6-D3 P	C40	D40	1GC-P9-D3 P
1GC-P18-D3 N	A39	B39	1GC-P21-D3 N	1GC-P6-D3 N	C39	D39	1GC-P9-D3 N
1GC-P18-D2 P	A38	B38	1GC-P21-D2 P	1GC-P6-D2 P	C38	D38	1GC-P9-D2 P
1GC-P18-D2 N	A37	B37	1GC-P21-D2 N	1GC-P6-D2 N	C37	D37	1GC-P9-D2 N
1GC-P18-D1 P	A36	B36	1GC-P21-D1 P	1GC-P6-D1 P	C36	D36	1GC-P9-D1 P
1GC-P18-D1 N	A35	B35	1GC-P21-D1 N	1GC-P6-D1 N	C35	D35	1GC-P9-D1 N
1GC-P18-D0 P	A34	B34	1GC-P21-D0 P	1GC-P6-D0 P	C34	D34	1GC-P9-D0 P
1GC-P18-D0 N	A33	B33	1GC-P21-D0 N	1GC-P6-D0 N	C33	D33	1GC-P9-D0 N
GND	A32	B32	GND	GND	C32	D32	GND
GND	A31	B31	GND	GND	C31	D31	GND
1GC-P19-D3 P	A30	B30	1GC-P22-D3 P	1GC-P7-D3 P	C30	D30	1GC-P10-D3 P
1GC-P19-D3 N	A29	B29	1GC-P22-D3 N	1GC-P7-D3 N	C29	D29	1GC-P10-D3 N
1GC-P19-D2 P	A28	B28	1GC-P22-D2 P	1GC-P7-D2 P	C28	D28	1GC-P10-D2 P
1GC-P19-D2 N	A27	B27	1GC-P22-D2 N	1GC-P7-D2 N	C27	D27	1GC-P10-D2 N
1GC-P19-D1 P	A26	B26	1GC-P22-D1 P	1GC-P7-D1 P	C26	D26	1GC-P10-D1 P
1GC-P19-D1 N	A25	B25	1GC-P22-D1 N	1GC-P7-D1 N	C25	D25	1GC-P10-D1 N
1GC-P19-D0 P	A24	B24	1GC-P22-D0 P	1GC-P7-D0 P	C24	D24	1GC-P10-D0 P
1GC-P19-D0 N	A23	B23	1GC-P22-D0 N	1GC-P7-D0 N	C23	D23	1GC-P10-D0 N
GND	A22	B22	GND	GND	C22	D22	GND
GND	A21	B21	GND	GND	C21	D21	GND
1GC-P20-D3 P	A20	B20	1GC-P23-D3 P	1GC-P8-D3 P	C20	D20	1GC-P11-D3 P
1GC-P20-D3 N	A19	B19	1GC-P23-D3 N	1GC-P8-D3 N	C19	D19	1GC-P11-D3 N
1GC-P20-D2 P	A18	B18	1GC-P23-D2 P	1GC-P8-D2 P	C18	D18	1GC-P11-D2 P
1GC-P20-D2 N	A17	B17	1GC-P23-D2 N	1GC-P8-D2 N	C17	D17	1GC-P11-D2 N
1GC-P20-D1 P	A16	B16	1GC-P23-D1 P	1GC-P8-D1 P	C16	D16	1GC-P11-D1 P
1GC-P20-D1 N	A15	B15	1GC-P23-D1 N	1GC-P8-D1 N	C15	D15	1GC-P11-D1 N
1GC-P20-D0 P	A14	B14	1GC-P23-D0 P	1GC-P8-D0 P	C14	D14	1GC-P11-D0 P
1GC-P20-D0 N	A13	B13	1GC-P23-D0 N	1GC-P8-D0 N	C13	D13	1GC-P11-D0 N
GND	A12	B12	GND	GND	C12	D12	GND
GND	A11	B11	GND	GND	C11	D11	GND
+3V3_OUT	A10	B10	+3V3_OUT	+3V3_OUT	C10	D10	+3V3_OUT
+3V3_OUT	A9	B9	+3V3_OUT	+3V3_OUT	C9	D9	+3V3_OUT
GND	A8	B8	GND	GND	C8	D8	GND
+VIN	A7	B7	+VIN	+VIN	C7	D7	+VIN
+VIN	A6	B6	+VIN	+VIN	C6	D6	+VIN
+VIN	A5	B5	+VIN	+VIN	C5	D5	+VIN
+VIN	A4	B4	+VIN	+VIN	C4	D4	+VIN
+VIN	A3	B3	+VIN	+VIN	C3	D3	+VIN
+VIN	A2	B2	+VIN	+VIN	C2	D2	+VIN
GND	A1	B1	GND	GND	C1	D1	GND

Board-to-Board Reference Design Package

Connect Tech Product a complete reference design package for the XBG301 breakout board. This details how to properly interface to the XDG201 Switch.

This package contains the following for the XBG301 Breakout Board:

- Altium Designer ECAD Source Files
- PDF Schematic Files
- Gerbers / Manufacturing Files
- Bill of Materials
- Tech Data / B2B Pinout Information
- 3D Models (as well for the Switch Module and Heatspreader)

The Reference Design Package can be downloaded here:

http://www.connecttech.com/ftp/Reference_Designs/XBG301_Reference_Design_Package.zip

SFP and SFP+ CU Transceiver Support

The XDG201 has support for the CISCO Compatible/ Equivalent GLC-T, additional support for CU transceivers can be found in the following link.

<http://connecttech.com/resource-center/kdb360-xtreme10g-managed-ethernet-switchrouter-sfpsfp-transceiver-modules/>

Switch Details

DIP Switch Details (S1)

Ensure – S1 Lower Switch Position is set to “RUN” at all times.

Moving the switch to “RESET” will hold the entire device in RESET and will prevent the board from booting.

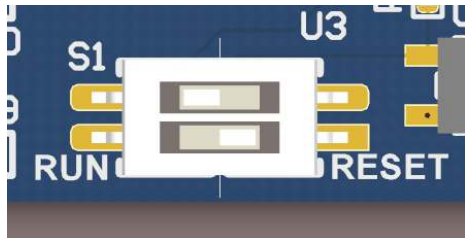

Typical Installation

1. Install XHG201 heatplate to XDG201 module.
2. Prepare breakout/carrier board with 4 x M3 8mm standoffs.
3. Ensure breakout/carrier board will be supplying module with +12V DC.
4. Mate board-to-board connector from XDG201 module to that of the breakout/carrier board.
5. Turn power ON to breakout/carrier board, XDG201 will now boot up.

On-Board Indicator LED's

The XDG201 has 2 on-board indicator LEDs.

LED Designator	Description
PWR	Power Good Indicator - If this LED is ON, this indicates that all on-board power supplies are ON and at the proper level.
Status	System Status Indicator - Function TBD

CLI Management Interface

CLI Access via External Serial Port

To use the CLI management on the XDG you must connect to the external management serial port. Only TX, RX and GND connections are needed for operation. You then must open the serial port in a terminal program such as: RealTerm, Putty, HyperTerminal, minicom, etc. The COM port must be set up to run with a baud rate of **115200, 8 data bits, 1 stop bit and no parity**.

RS-232 Serial Parameter	Value
Baud Rate	115200 bps
Data Bits	8
Parity	None
Stop Bit	1

CLI Basics

Once opening the COM port attached to the management port, after boot up your terminal output should look like the output below. The **default login is admin** and **password is blank(“”)**. **So after typing admin** hit <ENTER> then hit <ENTER> again to login and “?” will display a list of the available commands.

Below is a list of common quick CLI commands. For a complete CLI reference please see the documents described below.

Common Task	CLI Command Syntax
What are the IP addresses used by my switch?	<code>show ip int br</code>
What ports are linked and at what speed?	<code>show int * status</code>
What software version is on my switch?	<code>show ver</code>
How do I save my configuration?	<code>copy running-config startup-config</code>
How do I setup my IP address for vlan1?	<code>conf t</code> <code>int vlan 1</code> <code>ip add xxx.xxx.xxx.xxx 255.255.255.0</code> <code>end</code>

Complete CLI and Protocol Configuration Reference Guide

The complete CLI and Protocol Configuration reference guide from Microsemi for the VSC7448 device can be **[downloaded here](#)**.

The following documents:

- AN1104-Software_Configuration_Guide_ICLI
- AN1115Layer2ProtocolConfigurationGuide

Will have the below mentioned copyright notice.

Copyright 2002-2015 Microsemi Corporation. All Rights Reserved. Unpublished rights reserved under the copyright laws of the United States of America, other countries and international treaties. Microsemi retains all ownership, copyright, trade secret and proprietary rights in the documentation.

Web Management Interface

The Xtreme/10G Managed Ethernet Switch/Router allows users to configure and monitor the device from any web enabled device. Below describes how to access this management interface as well as provides an overview on the web GUI itself.

Accessing the Web Management Interface

There are two ways to access the web interface for first time use.

Method #1 - Using the default shipping IP

This method DOES NOT require having access to the CLI interface. By default the Xtreme/10G will have an IP address of **10.10.10.1**, if you would like to connect to this address follow the steps below:

- Directly connect any port of Xtreme/10G to your host PC using a standard Cat5e ethernet cable
- Setup your host PC's IP address to be on the same subnet as Xtreme/10G (10.10.10.X)
- Open a web browser and go to the 10.10.10.1 address.
- Now you should see the login screen and from here you can setup the Xtreme/10G to an IP address on your network.

Method #2 – Changing the Xtreme/10G IP to one on your network via the CLI

This method requires having access to the CLI interface through means of the external management serial port or the PCIe/104 bus

- Login to the CLI interface
- Type in the following commands
- configure terminal
- interface vlan 1
- ip address xxx.xxx.xxx.xxx 255.255.255.0
- end
- Now connect Xtreme/10G to any place on your network.
- Once the system is up simply go to your specified address of xxx.xxx.xxx.xxx in a web browser of your choice and you will see the login screen for the web interface

Login Screen of Web Management Interface

To login into the web management interface, the default login is **admin** and the password is blank.
(See below)

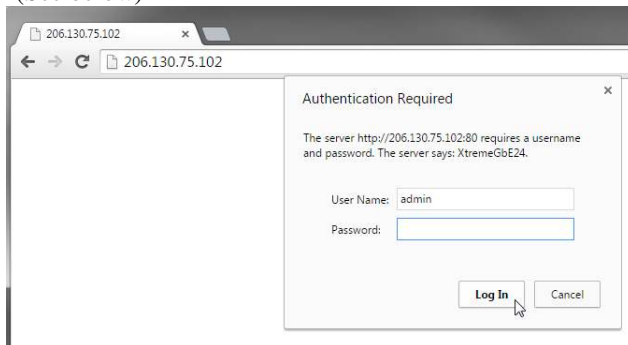

Web Management Interface Overview

<Complete Details Coming Soon>

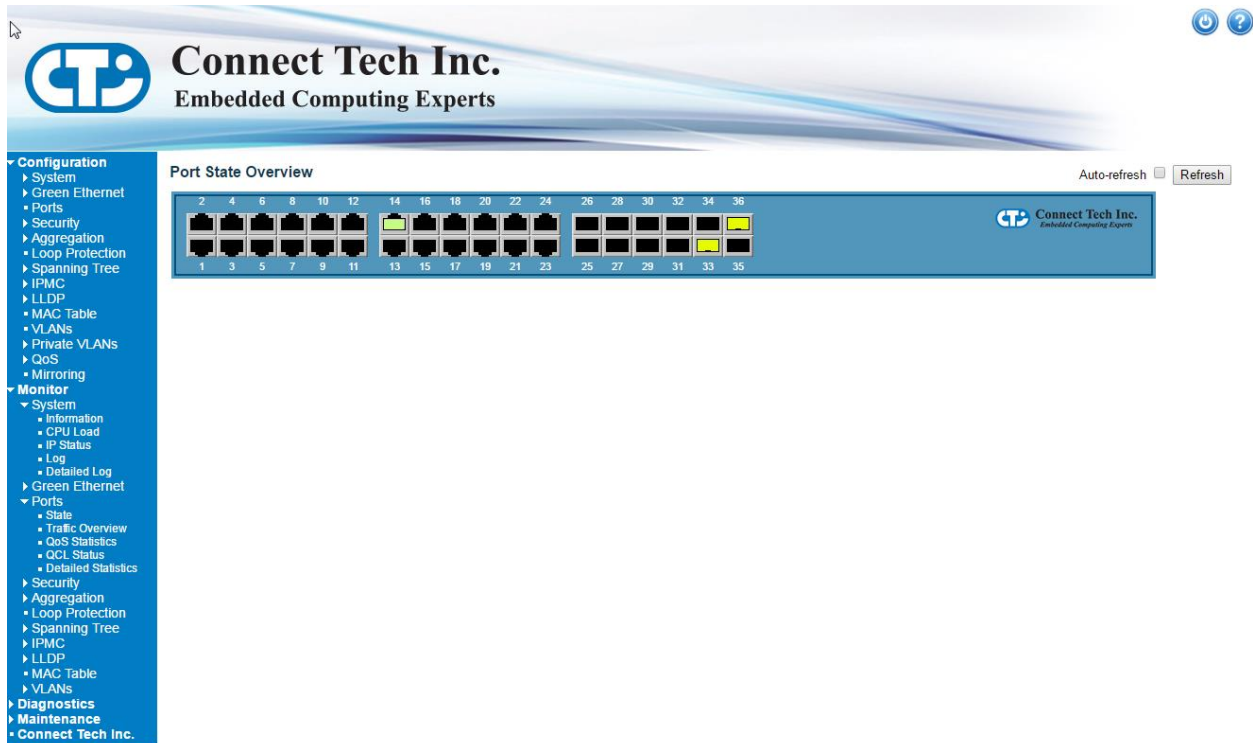

Complete Web Protocol Configuration Reference Guide

As mentioned in the CLI section, the complete Protocol Configuration reference guide from Microsemi for the VSC7429 device can be [downloaded here](#). It will have CLI and Web configuration methods listed.

The following document:

- **AN1115Layer2ProtocolConfigurationGuide**

Will have the below mentioned copyright notice.

Copyright 2002-2015 Microsemi Corporation. All Rights Reserved. Unpublished rights reserved under the copyright laws of the United States of America, other countries and international treaties. Microsemi retains all ownership, copyright, trade secret and proprietary rights in the documentation.

Breakout Boards

The XDG201 product can be integrated into any custom designed motherboard, or custom design breakout specifically for the XDG201. It can also be used with CTI's line of COTS breakout boards as well, so that no additional development is needed. These COTS breakout boards can be used for proof of concept or for direct field deployment.

XBG301 – Embedded Carrier

CTI has developed the XBG301, which is a COTS breakout board solution for the XDG201 switch. This breakout board is also meant to serve as a Reference Design platform for customers to use for their own development purposes. CTI provides full Bill of Materials, Schematics, Layout files and user documentation for the XBG301 embedded carrier in a Reference Design Package.

The Reference Design Package for this breakout board be downloaded here:

http://www.connecttech.com/ftp/Reference_Designs/XBG301_Reference_Design_Package.zip

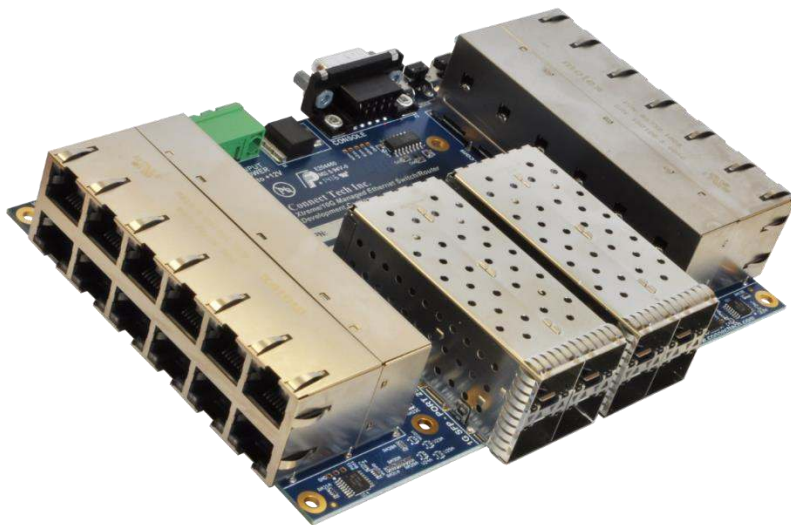

XBG301 – Embedded Carrier Specifications

Feature	Description
Ports	4x 10G (SFP+) 4x 1G (SFP) 24x 1G (RJ-45)
Console	1x RS-232 (via DB-9)
Input Voltage	+5V to +14V DC (4-pin 5mm pitch terminal header)
Dimensions	167.07mm x 125.84mm x 49.10mm (when XDG201 + XHG201 heat spreader are installed)
Console	1x RS-232 (via DB-9)



XBG301 + XDG201 + XHG201 – Dimensioned Drawing

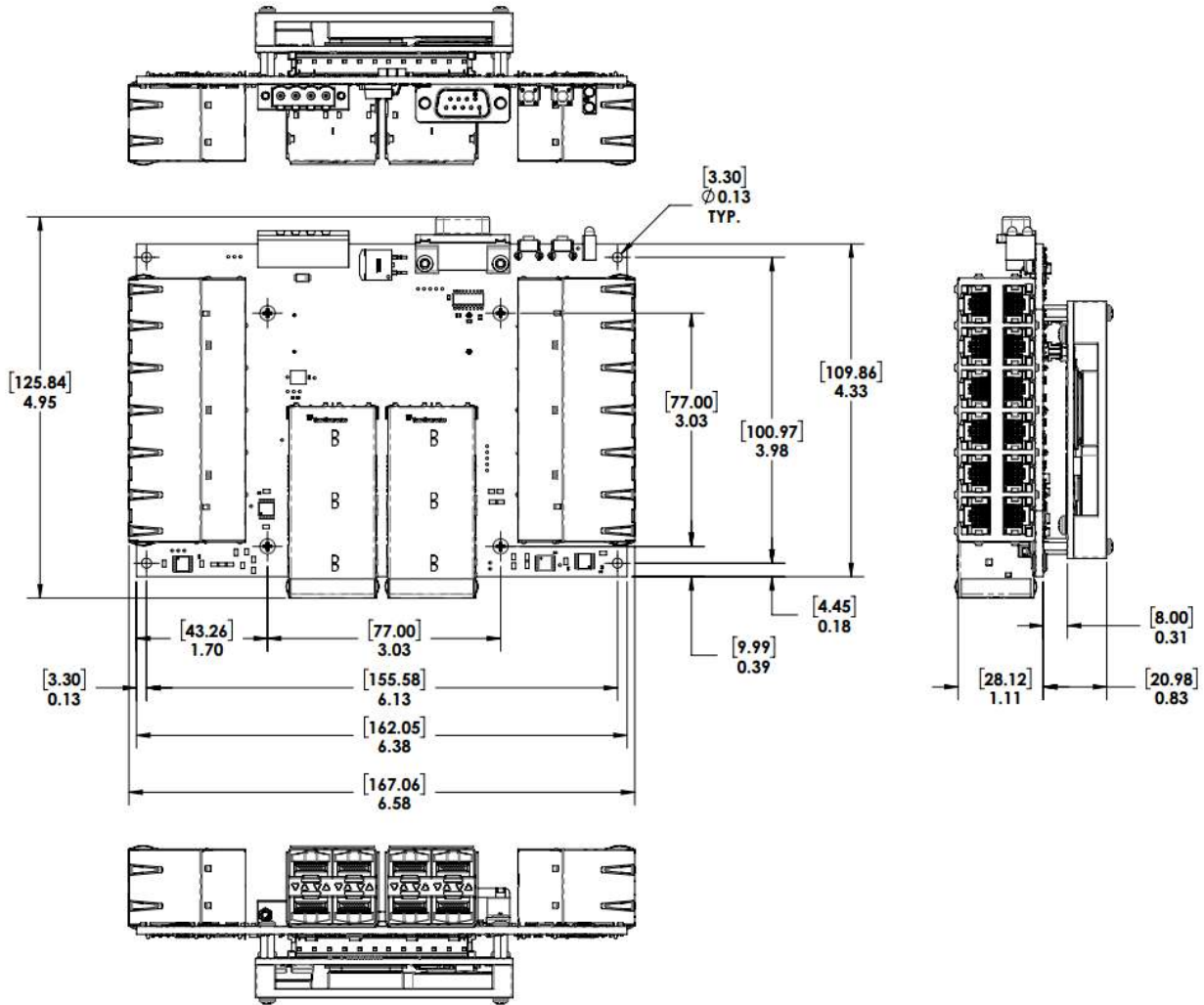



XBG301 + XDG201 + XHG201 – Assembly Drawing

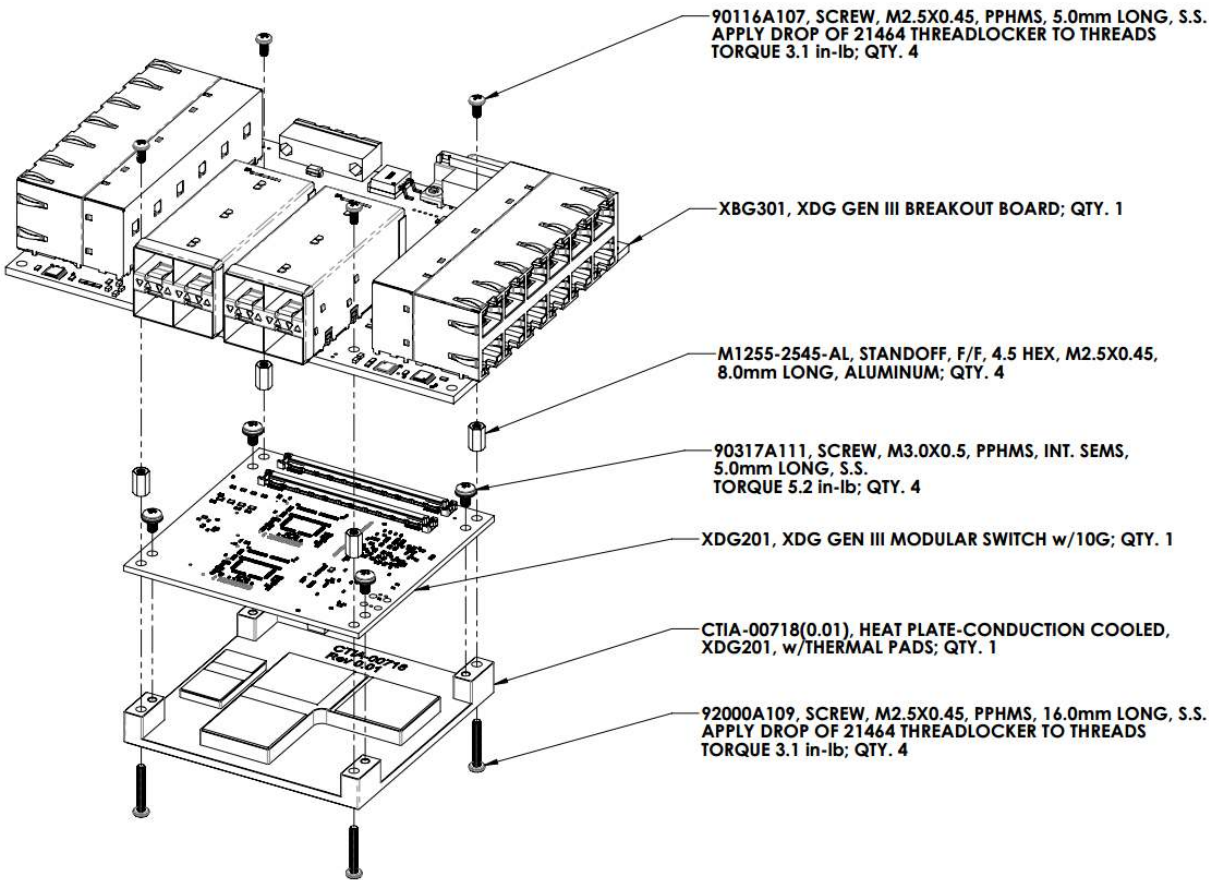

Thermal Details

XDG201 Thermal Parameters

Thermal Parameter	Value
Minimum Ambient Operating Temperature	-40 °C
Maximum Operating Junction Temperature of all chipsets	125 °C
Total Solution TDP	24 W
Die junction to package case top (SoC/PHY)	3.27 °C/W
Die junction to PCB (SoC/PHY)	6.03 °C/W
Die junction to Ambient (SoC/PHY)	12.14 °C/W
Die junction to moving air @ 1 m/s (SoC/PHY)	9.42 °C/W

XHG201 – Conduction Cooled Heatplate

The XHG201 is a flat heatplate that can be used to interface the XDG201 to another thermal extraction layer (chassis wall, finned heat sink etc). It is not intended to be used in a standalone application. [View the heatplate drawing.](#)

Current Consumption Details

Below are the maximum ratings of the XDG201 Switch.

Theoretical Maximum	Amps	Watts
Theoretical absolute maximum total draw of all functionality on the board	2.00	24

Below are measurements taken with the XDG201 Switch running in various configurations.
All measurements below are used with **+12V applied** to the Input Power Connector.

Actual Measurements	Amps	Watts
Idle No Links Up	1.17	14.04
1x 1G Link Up	1.20	14.40
24 x 1G Links Up	1.76	21.12
24 x 1G, 4 x 1G SFP, 4 x 10G SFP+ Up	1.81	21.72

Mechanical Details

3D Model

Download Link: http://www.connecttech.com/ftp/3d_models/XDG201_3D_MODEL.zip

2D Drawing (Top Side)

Dimensions in millimeters

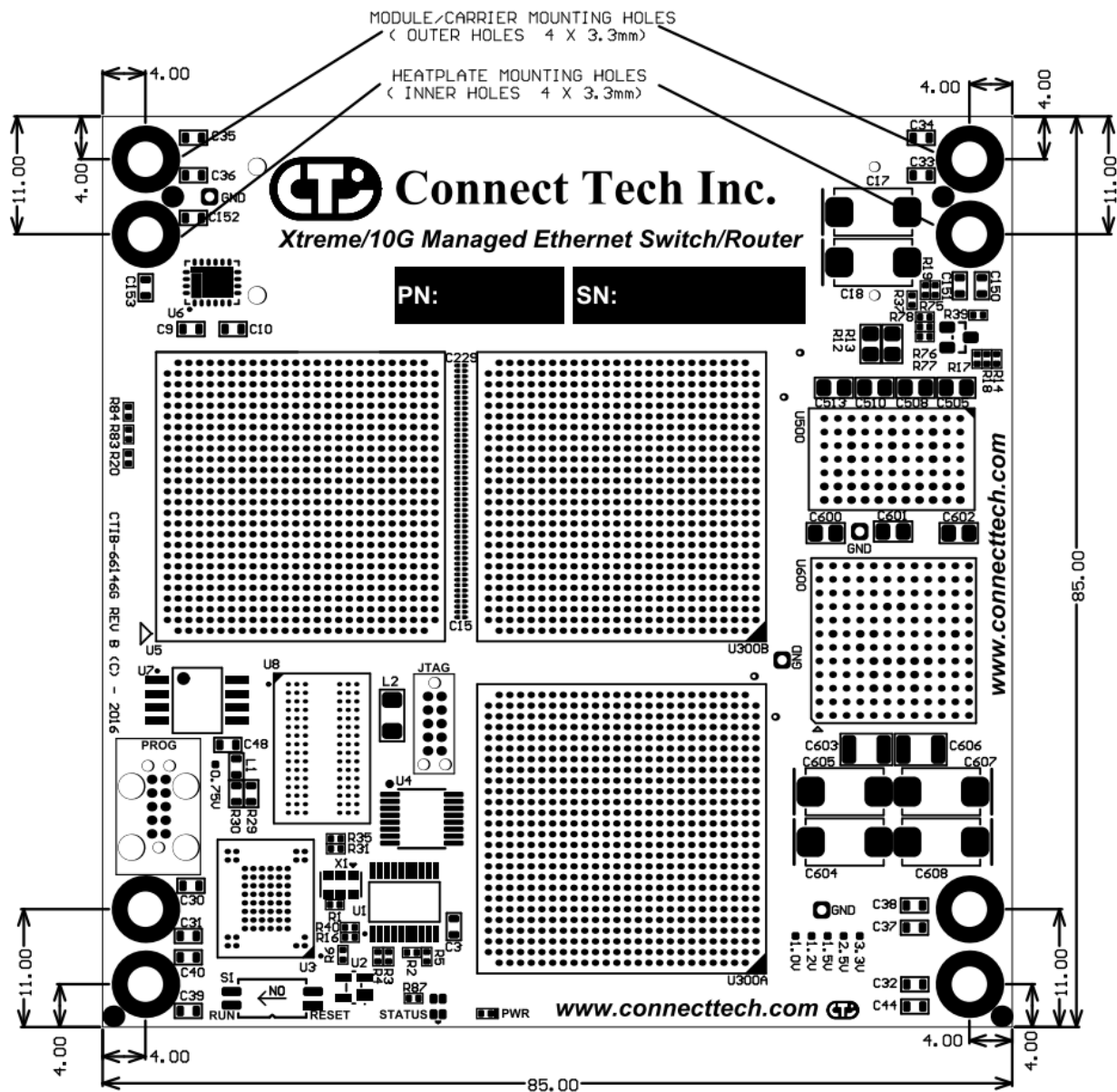



2D Drawing (Bottom Side)

Dimensions in millimeters – Location of Pin 1 detailed below

