



ADVANCED 2.4GHZ RADIO CONTROL SYSTEM

Download the other languages here..

Téléchargez ici les autres langues.

Download de andere talen hier.

Hier können Sie die anderen Sprachen herunterladen.



Version : 2021-06-04

INSTRUCTION MANUAL

WARNING and SAFETY PRECAUTION

The following terms are used throughout the product literature to indicate various levels of potential harm when operating this product.

CAUTION: Procedures, which if not be properly followed, is able to create a possibility of physical property damage AND or possibility of injury.

ATTENTION: Read the ENTIRE instruction manual to become familiar with the features of the product before operating. Fail to operate the product correctly can result in damage to the product, personal property and cause serious injury.

ATTENTION: This is a sophisticated hobby product and NOT a toy. It must be operated with caution and common sense and requires some basic mechanical ability. Fail to operate this Product in a safe and responsible manner could result in injury or damage to the product or other property. This product is not intended for use by children without direct adult supervision. Do not attempt to disassemble, use with incompatible components or augment product in any way without the approval of Corally. This manual contains instructions for safety, operation and maintenance. It is essential to read and follow all the instructions and warnings in the manual, prior to assembly, setup or use, in order to operate correctly and avoid damage or serious injury.

SPECIFICATIONS

- 2CH Transmitter with 3-channel receiver.
- The device has an integrated 2.4GHz antenna.
- Steering DUAL RATE (D/R).
- Steering and throttle Trims.
- Steering and throttle Reverse
- Fail Safe

TRANSMITTER

Model Type: Car/Boat
RF power: <20dBm
Modulation: GFSK
Sensitivity: 1024
Low Voltage Warning: <4,5V
Power: 6 VDC (1.5V AA x4)
Range: 400m
Size: 220 x 150 x 100 mm
Weight: 328 g
Certificate: CE0678 - FCC

RECEIVER

Channels: 3
Model type: car/boat
Frequency band: 2.4 GHz
Modulation: GFSK
Sensitivity: 1024
RF receiver sensitivity: -100 dbm
Power: 4.5–7.2 vdc
Weight:5 g
ANT length:26 mm
Size: 37.6 x 22.3 x 13 mm
Certificate: CE0678 FCC

TRANSMITTER

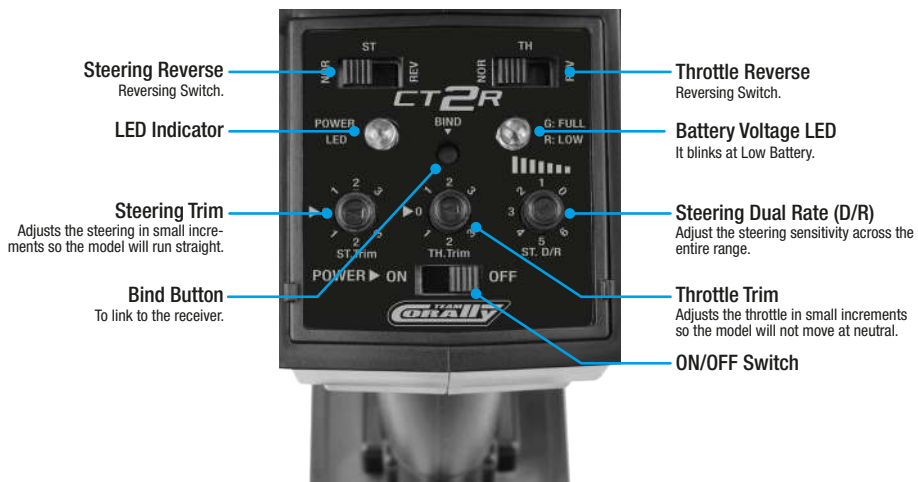

WARNING : Do not cover/hold the built-in antenna part of the transmitter by your hand during running. Do not put any conductive plate/sticker on the antenna part. Otherwise, the operating range may become shorter.

BATTERY INSTALLATION / REPLACEMENT



Remove the cover and insert 4 AA size batteries.
Observe the polarity markings and insert accordingly. Power ON the transmitter and check the Led status.
Battery Voltage LED - SOLID GREEN = OK
Battery Voltage LED -SOLID RED = Low Voltage (Replace batteries)

TRANSMITTER FUNCTIONS

ON/OFF SWITCH



Slide LEFT to turn ON the transmitter

LED Status



SOLID RED = OK
FLASHING RED = Low Voltage (Replace batteries)

SERVO REVERSE SWITCHES



ST.REV (Steering Reverse) :This function reverses the rotation direction of the STEERING servo.

TH.REV (Throttle Reverse) :This function reverses the rotation direction of the THROTTLE servo.

TRANSMITTER FUNCTIONS

STEERING TRIM

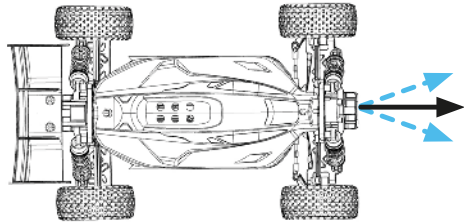

The steering trim is used to adjust the steering setting so that the car moves in a straight line without using the steering wheel to compensate.

THROTTLE TRIM

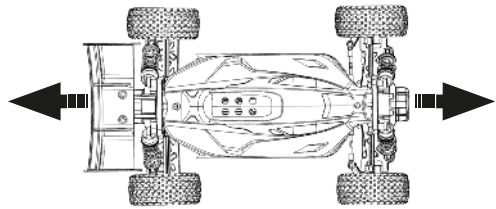

The throttle trim is used to adjust the setting of the neutral position of the throttle without using the throttle/brake trigger to compensate.

STEERING DUAL RATE (D/R)

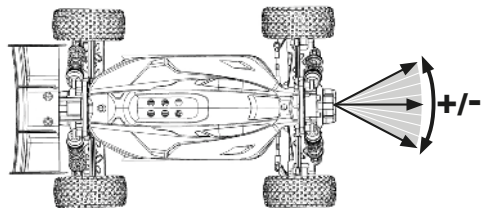

Use this function to adjust the steering travel of your model. If the model understeers while cornering, add steering by turning CW of the D/R button. When the model oversteers, take away steering by turning CCW of the D/R button.

OPERATE YOUR MODEL

MOVE YOUR MODEL

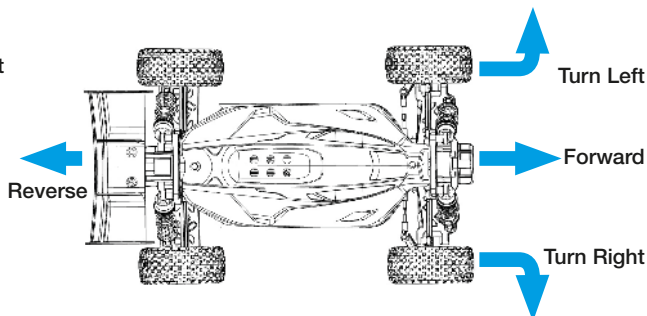
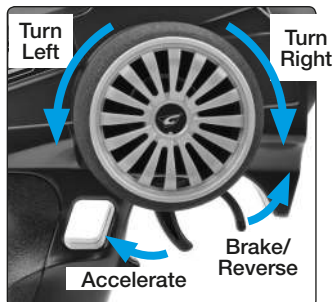

1. Gently pull the trigger to move your model forward.
The speed is proportional, the more you pull the trigger, the faster the model moves forward.
2. Release the trigger in neutral position to slow down your model.
3. Pull the trigger forward to brake your model.
For reverse, after stopping the model, release the trigger to neutral position then pull the trigger forward again to activate reverse.

RECEIVER

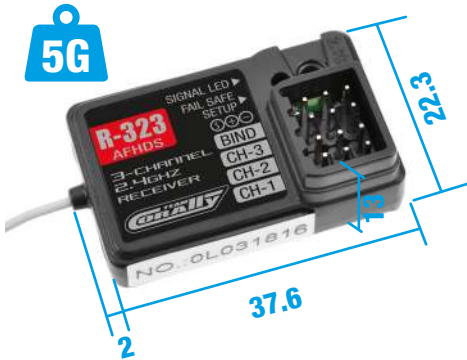

PLEASE NOTE: The channels "BIND" and "CH3" are not switched to reach a higher transmission rate.

RECEIVER CONNECTION

CONNECTION WITH A ESC

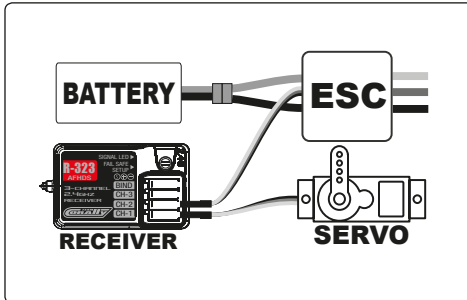

GAS POWERED MODEL

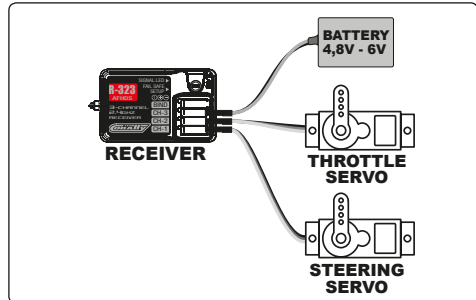

Install the Receiver in your model using double-sided Velcro. Velcro will hold the receiver in place and protect it from vibrations. Mount the antenna up and away from the vehicle in an antenna tube. The higher up the antenna is, the better signal it will receive.

Install and connect the receiver, servos and other components in accordance with the "Assembly Precautions".

CAUTION: NEVER CUT THE ANTENNA

BINDING / LINKING THE RECEIVER AND TRANSMITTER



The transmitter and receiver are already paired at the factory and you do not have to do anything. If you wish to connect the receiver with another transmitter or connect a new receiver, or if you have a problem with the link, follow the steps below to re-pair.

LINKING/BINDING PROCEDURE:

1. Install the batteries in the 2.4 GHz radio. Transmitter on OFF.
2. Connect the supplied pairing cable to the "BIND" channel of the receiver.
3. Connect the battery to the receiver on one of its VCC ports, the red LED flashes: the receiver is in pairing status.
4. Press and hold the BIND button on the transmitter and turn it ON. (about 5 seconds)
5. Observe the LED on the receiver. If the LED stops flashing, the binding process is successful.
(This process takes up to 5 sec.).
6. Release the BIND button on the transmitter, remove the pairing cable from the receiver.
7. Perform a function test.
8. If the test is not successful, repeat the above steps.



FAIL SAFE SETUP

The "Fail Safe" mode is the ideal protection for your RC car, it prevents the loss of control of the car if there is a lack of connection between the transmitter and the receiver. This means that a position for channel 2 (Forward/Reverse) is determined, normally the NEUTRAL position is chosen for an electric car and the BRAKE position for a nitro car.

FAIL SAFE PROCEDURE

1. Turn ON the transmitter
2. Power up the receiver, the LED should be lit solid.
3. Position and hold the throttle trigger in the desired position;
NEUTRAL for an electric car, BRAKE for a nitro engine car.
4. Press the "FAIL SAFE SETUP" button on the receiver with the plastic pin provided.
The LED will flash for 3 seconds.
5. The setting is now stored.

TEST

1. Switch on the transmitter and then the receiver.
2. Switch off the transmitter.
3. The car must not move (electric car), the gas/brake servo must be in brake mode (nitro car).
4. If the test is not successful, repeat the above steps.

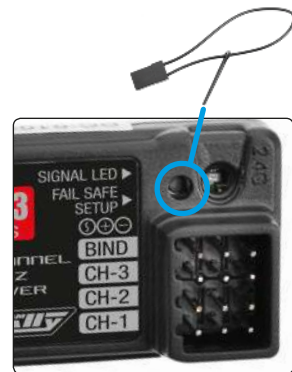

CAUTION

FCC Statement

This equipment has been tested and found to comply with the limits for a Class B digital device, pursuant to Part 15 of the FCC Rules. These limits are designed to provide reasonable protection against harmful interference in a residential installation. This equipment generates uses and can radiate radio frequency energy and, if not installed and used in accordance with the instructions, may cause harmful interference to radio communications. However, there is no guarantee that interference will not occur in a particular installation. If this equipment does cause harmful interference to radio or television reception, which can be determined by turning the equipment off and on, the user is encouraged to try to correct the interference by one or more of the following measures:

- Reorient or relocate the receiving antenna.
- Increase the separation between the equipment and receiver.
- Connect the equipment into an outlet on a circuit different from that to which the receiver is connected.
- Consult the dealer or an experienced radio/TV technician for help.

This device complies with part 15 of the FCC Rules. Operation is subject to the following two conditions:

(1) This device may not cause harmful interference, and (2) this device must accept any interference received, including interference that may cause undesired operation.

Changes or modifications not expressly approved by the party responsible for compliance could void the user's authority to operate the equipment.

PRECAUTIONS

- ❗ Check the receiver, servos, and battery connectors, to be sure they are firmly connected. If a connector is not fully inserted, vibration may cause the connector to work loose while the model is operating. This will result in loss of control.
- ❗ Operate each servo horn over its full stroke and check to see that the linkage does not bind or is not too loose. Excessive force applied to the servo horn by binding or poor installation may lead to servo problems and result in loss of control.
- ❗ **Electric Cars and Boats** : Isolate the receiver from vibration by attaching to the chassis or mounting plate with thick double sided tape.
Gas Powered Cars and Boats : Isolate the receiver from vibration by wrapping it in foam rubber or similar type cushioning material. Protect the unit from water damage by placing it in a plastic bag or waterproof radio box.
The receiver contains precision electronic parts. These parts are vulnerable to vibration and shock. Any contact with moisture (water or condensation) may cause receiver malfunction and loss of control.
- ❗ Keep all devices that emit high frequency noise, such as motors, batteries, and wiring that handles heavy current loads, at least 1/2 inch away from the receiver and the receiver antenna. High frequency noise will cause a decrease in operating range and could cause loss of control.
- ❗ Install electronic speed control heat sinks as well as other components that conduct electricity so they can not come in contact with aluminium, carbon fibre or other materials that conduct electricity.
If, for example, the speed control came loose while the model was running and touched an aluminium chassis, a short circuit may occur that would cause irreparable damage to the system as well as loss of control.
- ❗ Noise suppression capacitors should be installed on almost all motors. If the proper capacitors are not installed, high frequency noise will reduce range and cause loss of control along with various other problems.
- ❗ Inspect all linkage installations and any point where metal could come in contact with other metal parts. Make sure these parts do not touch other metal parts under vibration. Should a linkage or other metal parts come in contact with other metal parts under vibration, the high frequency noise generated by this contact will cause interference and possible loss of control.
- ❗ Do Not disassemble any part of this system that is not specified in the instruction manual. Corally will not be responsible for any damage due to improper disassembly of any part of the radio control system.

WARRANTY CONDITIONS & LIABILITY DISCLAIMER

If material defects or manufacturing faults should arise in a product distributed or manufactured by Team Corally / JSP Group Intl bvba, and purchased by a consumer, we Team Corally / JSP Group Intl bvba acknowledge the obligation to correct those faults or defects within the limitations described below. This manufacturer's warranty is in addition to, and does not affect, the legal or contractual rights of the consumer which arise from the purchase of such products. Team Corally / JSP Group Intl bvba guarantees the consumer that its products are free from material, manufacturing, and construction faults, as determined by the general state of knowledge and technology valid at the time of manufacturing. The fault responsible for causing the damage must be proven to have been present in the product at this time. Claims for compensation arising from consequential damage or product liability will not be considered valid unless they fall under peremptory provisions of the law. If material defects or manufacturing faults should arise in a product distributed or manufactured by Team Corally / JSP Group Intl bvba in the European community (EC) and purchased by a consumer, then Team Corally / JSP Group Intl bvba undertakes to correct those defects within the limitations described below. This manufacturer's declaration does not affect the consumer's legal or contractual rights regarding defects arising from the purchase contract between the consumer and the dealer or reseller. **Extend of the Warranty**

If a claim is made under warranty, we take at our discretion to repair or replace the defective goods. We will not consider supplementary claims, especially for reimbursement of costs relating to the defect (e.g. installation / removal costs) and compensation for consequent damages unless they are allowed by statute. This does not affect claims on legal regulations, especially according to the product liability law.

Provisions of the Warranty

The purchaser is required to make the warranty claim in writing, and must enclose original proof of purchase (e.g. invoice, receipt, delivery note) and the appropriate warranty card. He must send the defective goods to our local representatives or directly to Team Corally / JSP Group Intl bvba, Geelseweg 80, 2250 Olen, Belgium at his own risk and cost.

The purchaser should state the material defect or manufacturing fault, or symptoms of the fault, as accurate as possible, so that we can check if our warranty obligation is applicable. The goods are transported from the consumer to us, and from us to the consumer, entirely at the risk and cost of the consumer.

Invalidation of the Warranty

The consumer cannot make a claim under warranty when the fault is affecting the use of the product arising from natural wear, competition use, or improper use (including installation) or external forces. The consumer's adherence to the building and operating instructions relevant to the model, including the installation, operation, use of, and maintenance of, model-related components cannot be supervised by Team Corally / JSP Group Intl bvba. Therefore Team Corally / JSP Group Intl bvba is in no way liable for loss, damage, or costs resulting from improper use, or behaviour in any way connected to the above described provisions. Unless otherwise required by law, Team Corally / JSP Group Intl bvba is in no way whatever liable to provide compensation for damages arising from the improper use of the model (including personal injury, death, damage to buildings, loss of turnover, loss of business, or interruption of business, or any other direct, or indirectly caused, consequential damage).

Duration of Validity

The claim period is 24 months from the date of purchase of the product by the consumer from a dealer in the European Community (EC) counted from the date of purchase. The claim period is 12 months from the date of purchase of the product by the consumer from a dealer outside the European Community (EC) counted from the date of purchase. If a defect arises after the end of the claim period, or if evidence or documents required according to this declaration in order to make the claim valid are not presented until after this period, then the consumer forfeits any rights or claims from this declaration. The guarantee period is not prolonged by the granting of any claims within the framework of this warranty, especially in the case of repair or replacement. The guarantee period also does not restart in such cases.

Warranty Expiration

If we do not acknowledge the validity of a claim based on this declaration within the claim period, all claims based on this declaration will expire after six months from the time of registering the claim; however this cannot occur prior to the end of the claim period.

For any support, you can contact us by email at info@corally.com



WEEE: At the end of this device's useful life, please remove all the batteries and dispose of them separately. Take electrical appliances to the local collection points for waste electrical and electronic equipment. Other components can be disposed of in domestic refuse. Thank you for your co-operation!

DECLARATION OF CONFORMITY

EU-Konformitätserklärung • Déclaration de Conformité UE •

EU-Verklaring van Overeenstemming

(in accordance with ISO/IEC 17050-1) / (in Übereinstimmung mit ISO/IEC 17050-1) / (Conformément à la norme ISO/IEC 17050-1) / (In overeenstemming met ISO/IEC 17050-1)

Type Name/ Typ Name/ Nom/ Type Naam: **CT2R**

Description/ Beschreibung/ Description/ Beschrijving: **Transmitter**

Item Number/ Artikel Nummer/ Numéro d'article/ Artikel Nummer: **C-59060**

This declaration is issued under the sole responsibility of the manufacturer.

Die alleinige Verantwortung für die Ausstellung dieser Erklärung trägt der Hersteller.

La présente déclaration est établie sous la seule responsabilité du fabricant.

Deze verklaring wordt afgelegd onder de uitsluitende verantwoordelijkheid van de fabrikant.

Product(s)/Produkt(e)/Produit(s)/Product(en): **Corally CT2R**

-The object of declaration described above is in conformity with the relevant Union harmonization Legislation, specifically the requirements of the specifications listed below, following the provisions of the European RED Directive 2014/53/EU, 2011/65/EU (RoHS):

-Der Gegenstand dieser Erklärung ist konform mit den Harmonisierungsrechtsvorschriften der Europäischen Union, insbesondere mit den unten aufgeführten Bestimmungen, und folgt der europäischen RED Direktive 2014/53/EU, 2011/65/EU (RoHS)

-L'objet de la déclaration décrit ci-dessus est conforme à la législation pertinente en matière d'harmonisation de l'Union européenne, en particulier les exigences des spécifications énumérées ci-dessous, conformément aux dispositions des directives européennes RED 2014/53/EU, 2011/65/EU (RoHS)

-Het voorwerp van de hierboven beschreven verklaring voldoet aan de relevante EU-harmonisatiewetgeving, met name aan de eisen van de hieronder vermelde specificaties, in overeenstemming met de bepalingen van de EU-richtlijnen RED 2014/53/EU, 2011/65/EU (RoHS):

EMC: EN 301 489-1 V2.1.1

EN 301 489-17 V3.1.1

RADIO: EN 300 328 V2.1.1

SAFETY: EN 62479: 2010

EN 60950-1:2006+A11:2009+A1:2010+A12:2011+A2:2013

RoHS: EN 50581:2012

Signed for and on behalf of/ *Unterzeichnet für und im Namen von/* Signé pour et au nom de: */ Ondertekend voor en namens :*

JSP GROUP INTL • Geelseweg, 80 • 2250 Olen • Belgium

Place and Date/ *Ort und Datum/* Lieu et date/ *Plaats en datum:* **Olen, Belgium, 05 Juni 2021**

Name/ *Name/* Nom/ *Naam:* **Stefan Engelen**

Signature/ *Unterschrift/* Signature/ *Handtekening:*

Title/ *Titel/* Titre/ *Titel:* **Ceo**



WWW.CORALLY.COM

TEAM
CORALLY

WORLD CHAMPIONS



WWW.CORALLY.COM

Team Corally is a registered trademark licensed to
JSP Group Intl bvba • Geelseweg 80 • B-2250 OLEN • Belgium
Tel: +32 14 25 92 94 • Info@corally.com

FCC ID: 2A2FS-C59060

