

2 Dining Chairs & 2-Seater Bench
2 Chaises à Manger & Banc à 2 Places

THIS INSTRUCTION BOOKLET CONTAINS **IMPORTANT** SAFETY INFORMATION.
PLEASE READ AND KEEP FOR FUTURE REFERENCE.

EN



Before You Start

- ⚠ Please read all instructions carefully.
- ⚠ Retain instructions for future reference.
- ⚠ Separate and count all parts and hardware.
- ⚠ Read through each step carefully and follow the proper order.
- ⚠ We recommend that, where possible, all items are assembled near to the area in which they will be placed in use, to avoid moving the product unnecessarily once assembled.
- ⚠ Always place the product on a flat, steady and stable surface.
- ⚠ Keep all small parts and packaging materials for this product away from babies and children as they potentially pose a serious choking hazard.

FR



Avant de Commencer

- ⚠ Veuillez lire attentivement toutes les instructions.
- ⚠ Conservez les instructions pour vous y référer ultérieurement.
- ⚠ Vérifiez toutes les pièces et les accessoires.
- ⚠ Lisez attentivement chaque étape et suivez l'ordre correct.
- ⚠ Nous recommandons que, dans la mesure du possible, tous les produits soient assemblés à proximité de la zone où ils seront utilisés, afin d'éviter tout déplacement inutile du produit une fois assemblé.
- ⚠ Placez toujours le produit sur une surface plane et stable.
- ⚠ Conservez toutes les petites pièces de ce produit et les matériaux d'emballage hors de portée des bébés et des enfants, car ils pourraient présenter un risque d'étouffement.

Part List/Liste des Pièces

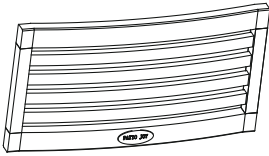

1 x2
Chair-Backrest
/Chaise - Dossier

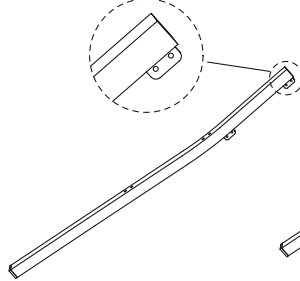

2 x3
Back- Right Chair Leg
/Arrière - Pied
de Chaise Droit

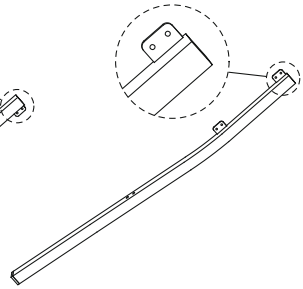

3 x3
Back- Left Chair Leg
/Arrière - Pied
de Chaise Gauche

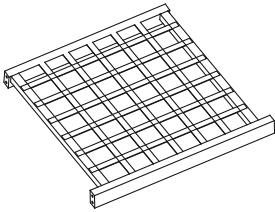

4 x2
Chair Seat
/Siège de Chaise

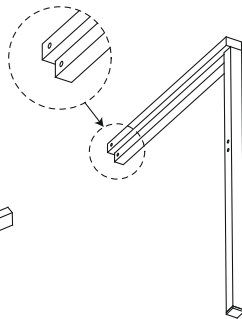

5 x3
Front- Right Chair Leg
/Avant - Pied de
Chaise Droit

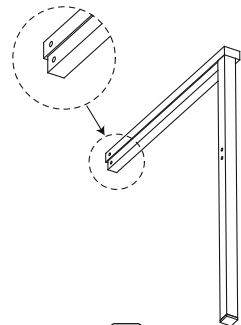

6 x3
Front- Left Chair Leg
/Avant - Pied de
Chaise Gauche

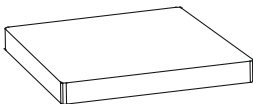

7 x2
Chair-Seat Cushion
/Chaise - Coussin de Siège

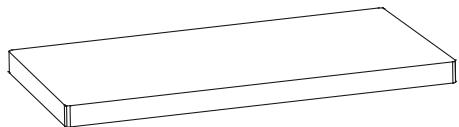

8 x1
Bench-Seat Cushion
/Banc - Coussin de Siège

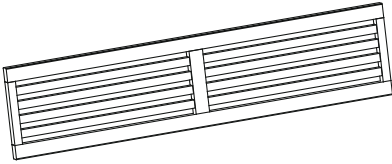

9 x1

Bench Backrest
/Dossier de Banc

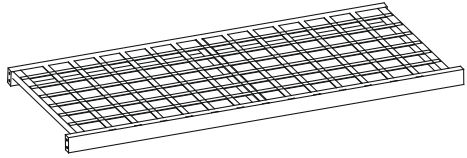

10 x1

Bench Seat
/Siège de Banc

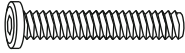

M6x40mm
Bolt/Boulon

A x30

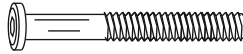

M6x55mm
Bolt/Boulon

B x6



M4x15mm
Screw/Vis

C x24



M6x16x2mm
Metal washer
/Rondelle en Métal

D x30



M6x16x5mm
Plastic Washer
/Rondelle en Plastique

E x12

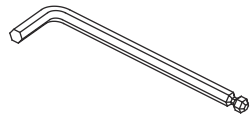

Allen key
/Clé Allen

F x2

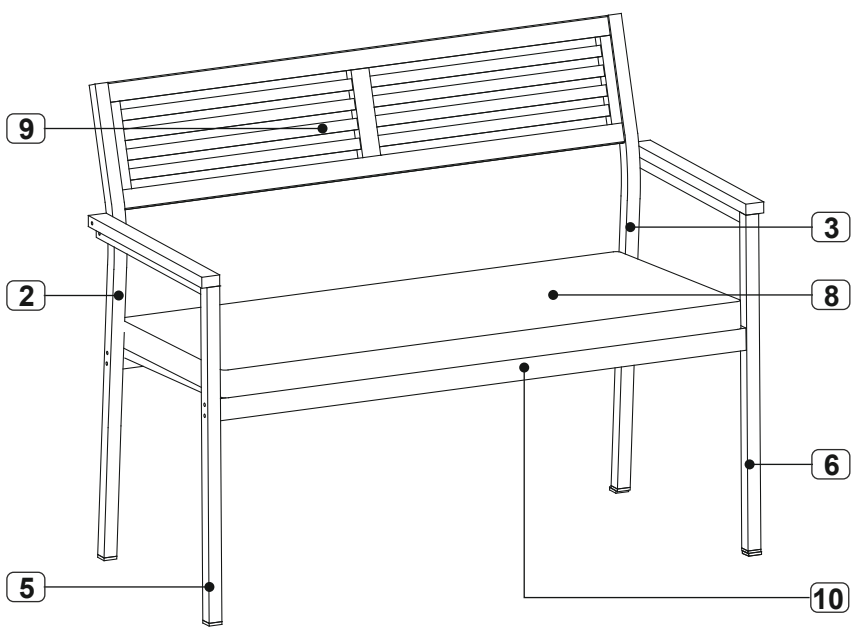
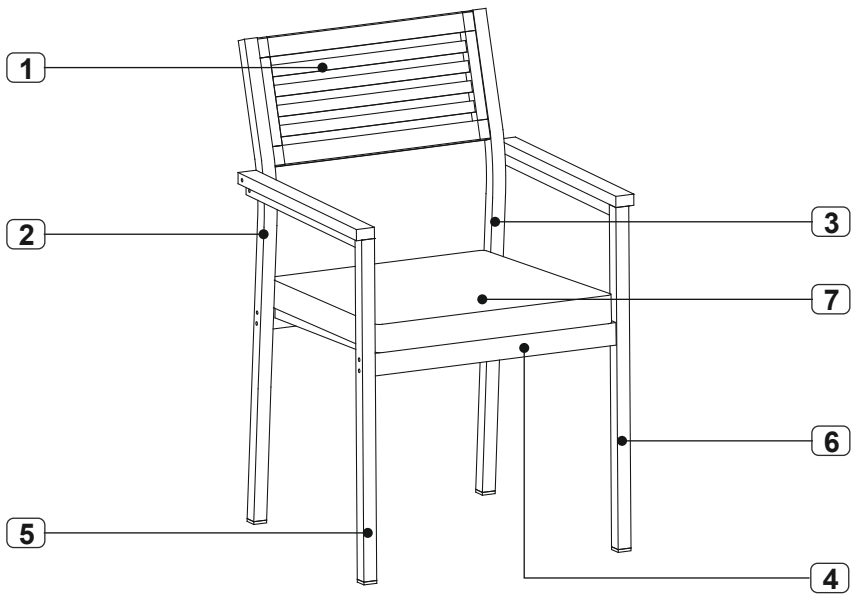

STEP 1/ÉTAPE 1

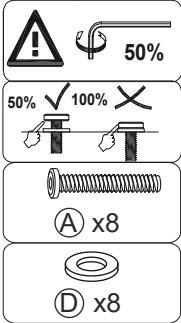

X2

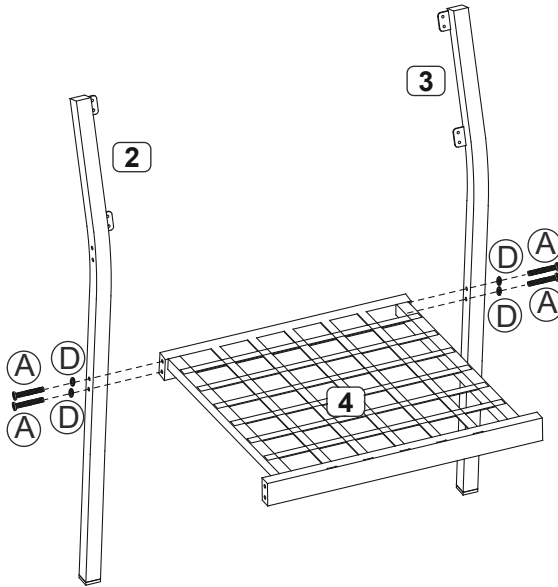

STEP 2/ÉTAPE 2

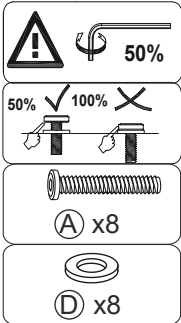

X2

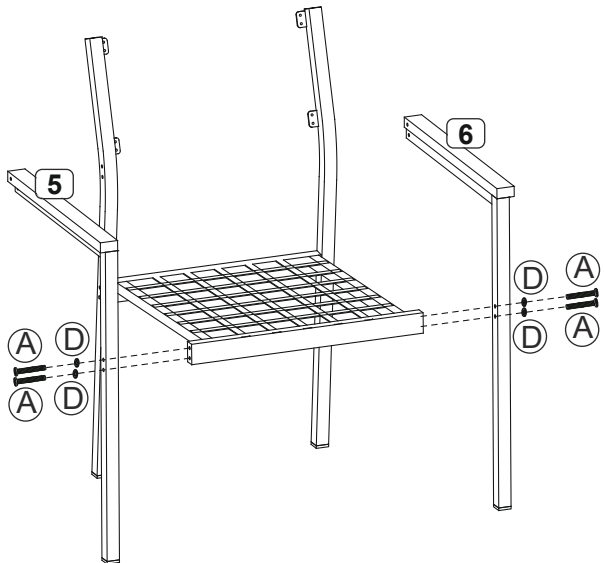

STEP 3/ÉTAPE 3

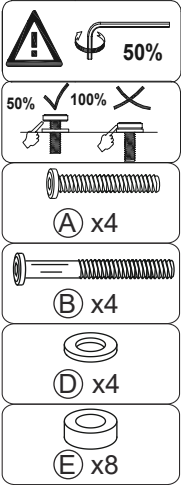

X2

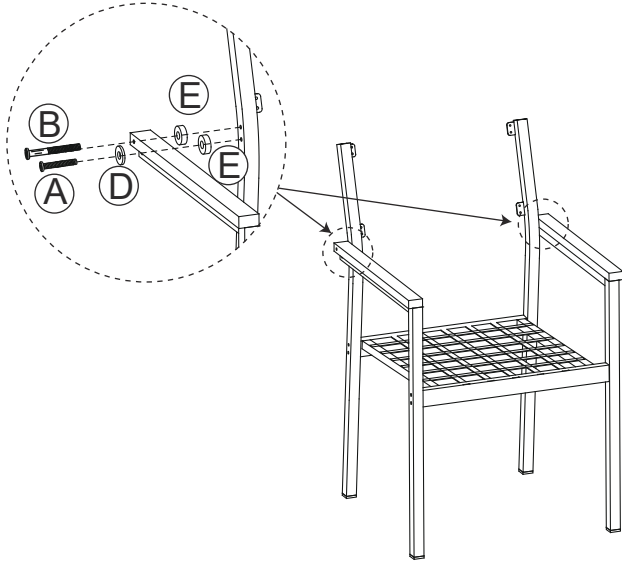

STEP 4/ÉTAPE 4

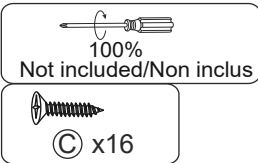

X2

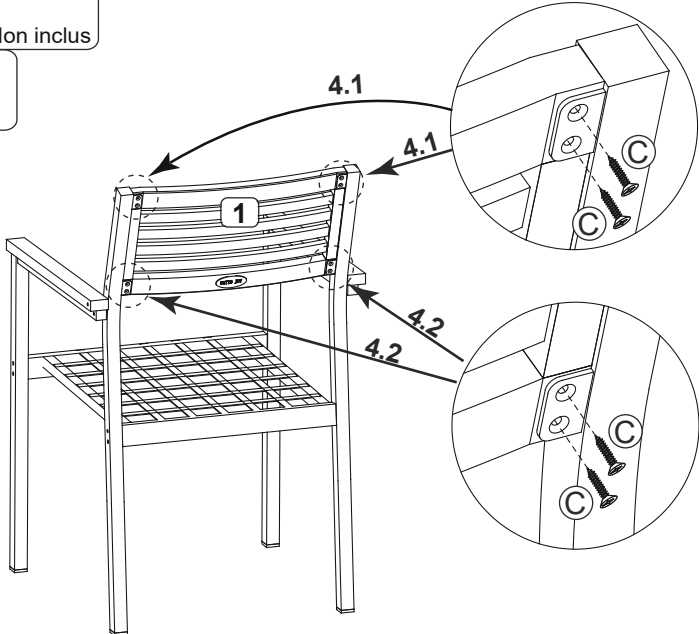

STEP 5/ÉTAPE 5

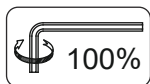

X2

Fully tighten all screws/bolts before placing the cushion seat and use!!!
/Serrez complètement toutes les vis/boulons avant de placer le coussin du siège et de l'utiliser !!!

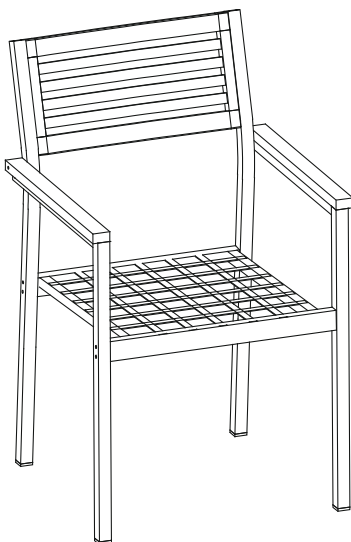

STEP 6/ÉTAPE 6

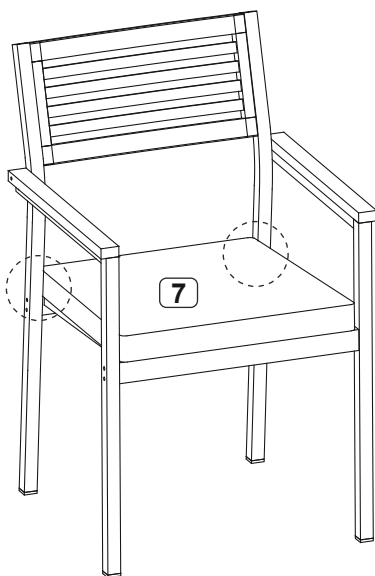
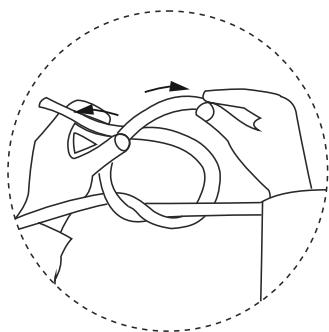

X2

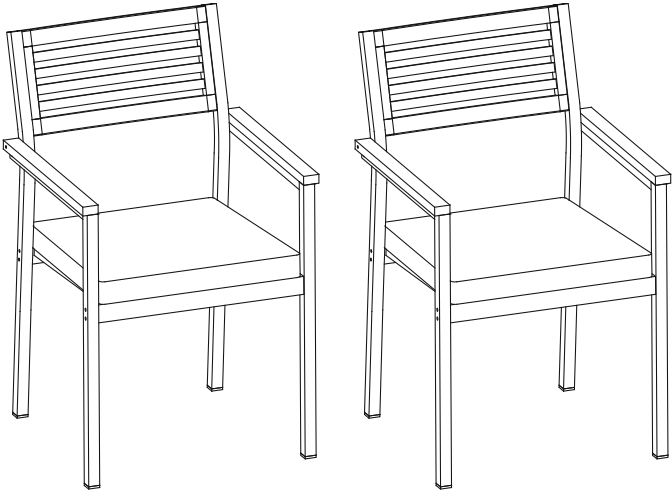

STEP 7/ÉTAPE 7



STEP 8/ÉTAPE 8

  50%

50% ✓ 100% ✗

 (A) x4

 (D) x4

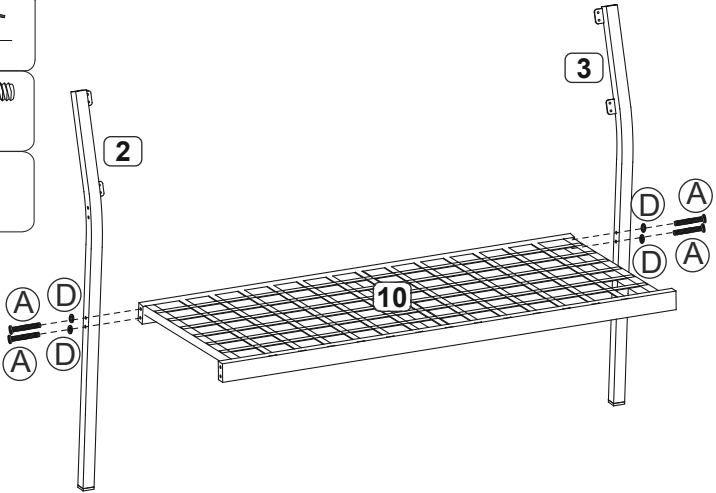

STEP 9/ÉTAPE 9

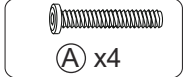
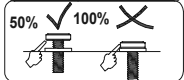

(A) x4

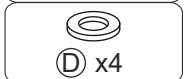

(D) x4

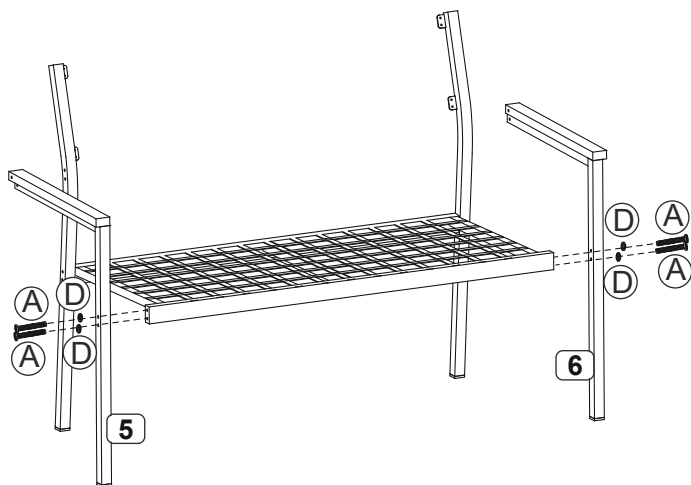

STEP 10/ÉTAPE 10

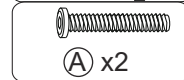
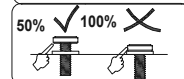
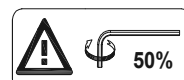

(A) x2

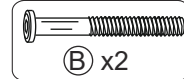

(B) x2

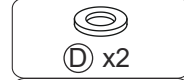

(D) x2



(E) x4

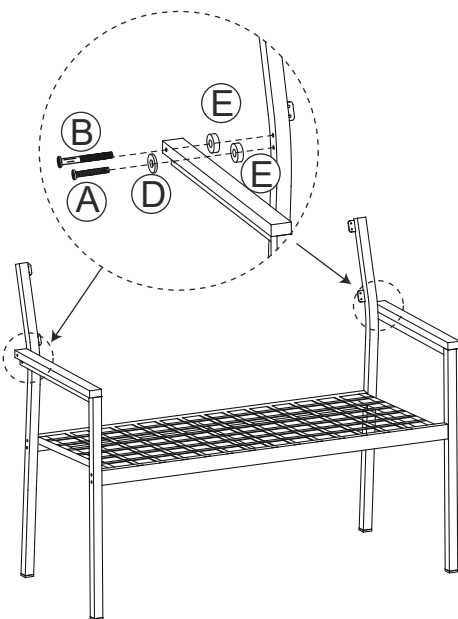

STEP 11/ÉTAPE 11

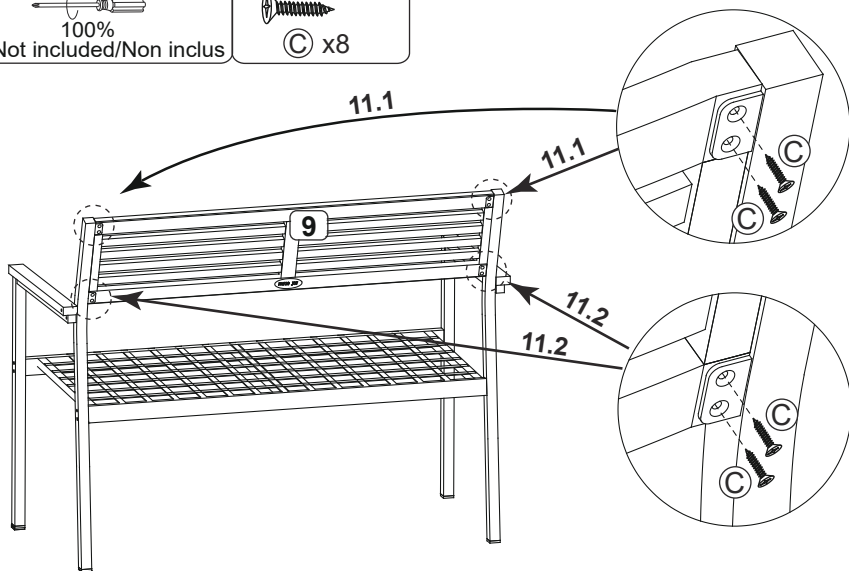
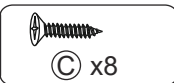
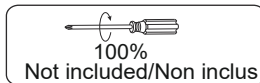

STEP 12/ÉTAPE 12

Fully tighten all
screws/bolts before
placing the cushion
seat and use!!!

/Serrez
complètement
toutes les
vis/boulons avant
de placer le coussin
du siège et de
l'utiliser !!!

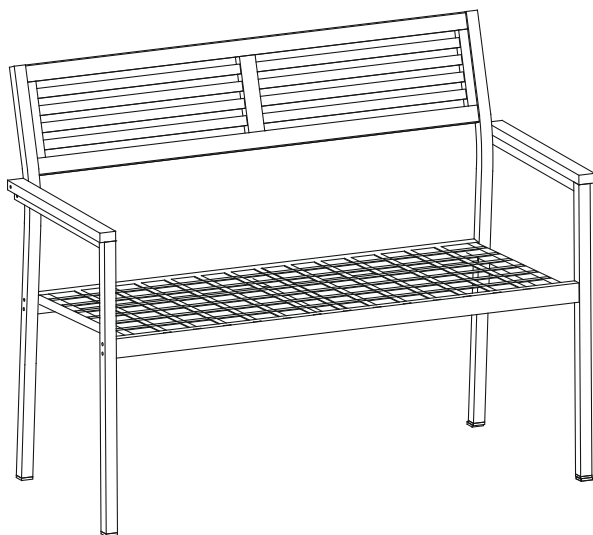

STEP 13/ÉTAPE 13

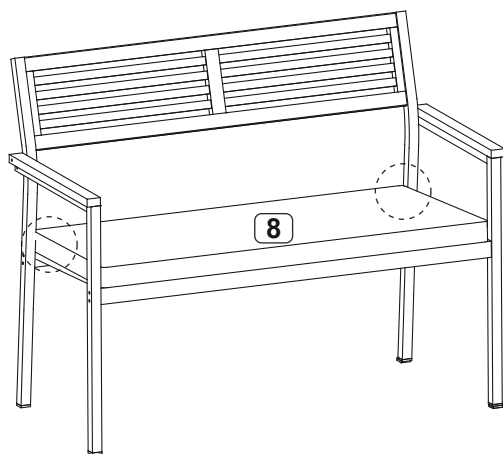
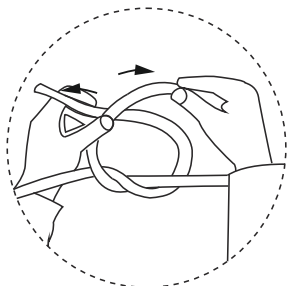

STEP 14/ÉTAPE 14

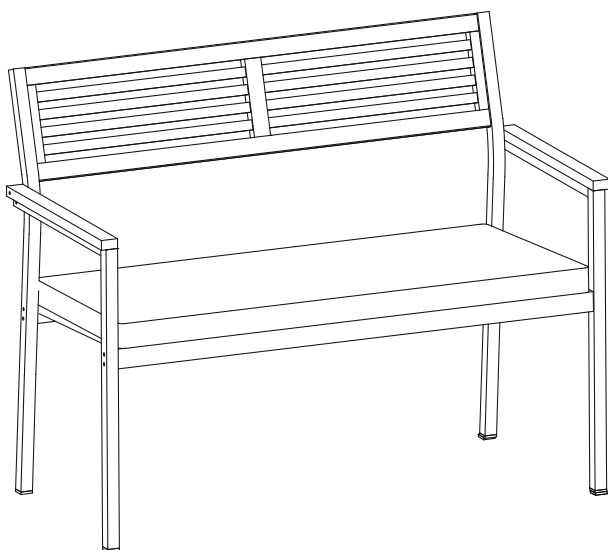

STACKING FUNCTION / FONCTION D'EMPILAGE

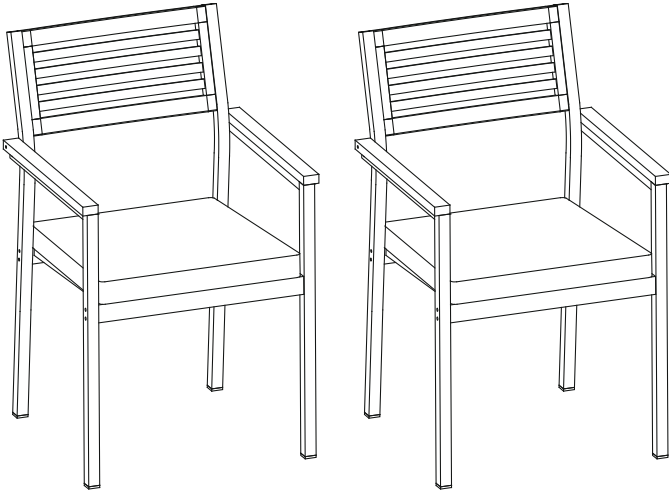

STACKING FUNCTION / FONCTION D'EMPILAGE

The chair can be stacked when not in use.
The cushions must be uninstalled before using the stacking function.
/La chaise peut être empilée lorsqu'elle n'est pas utilisée.
Les coussins doivent être désinstallés avant d'utiliser la fonction d'empilage.

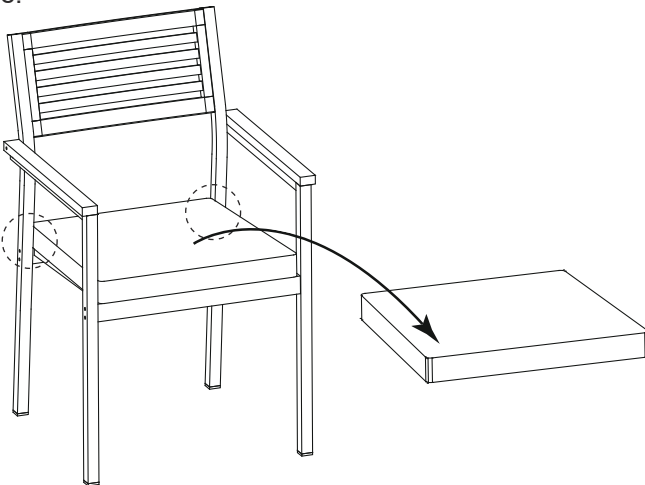

STACKING FUNCTION/FONCTION D'EMPILAGE

Then stack the chair on other chair one by one
/Empilez ensuite la chaise sur une autre
chaise, l'une après l'autre.

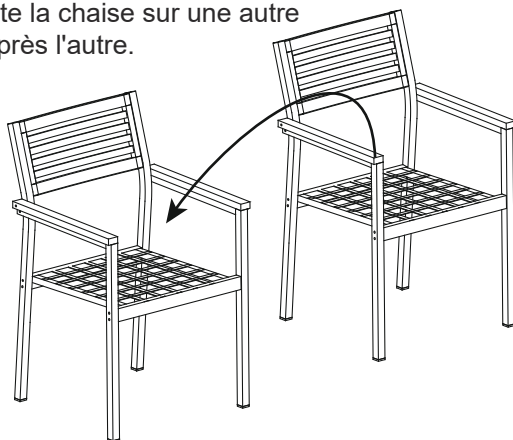

STACKING FUNCTION/FONCTION D'EMPILAGE

Lay 2 cushions on the upper chair then store.

The products should be covered with a cover before being stored to avoid dust, rust, and dirt while not in use for a long time.

/Poser 2 coussins sur la chaise supérieure, puis ranger.

Les produits doivent être recouverts d'une housse avant d'être stockés afin d'éviter la poussière, la rouille et la saleté lorsqu'ils ne sont pas utilisés pendant une longue période.

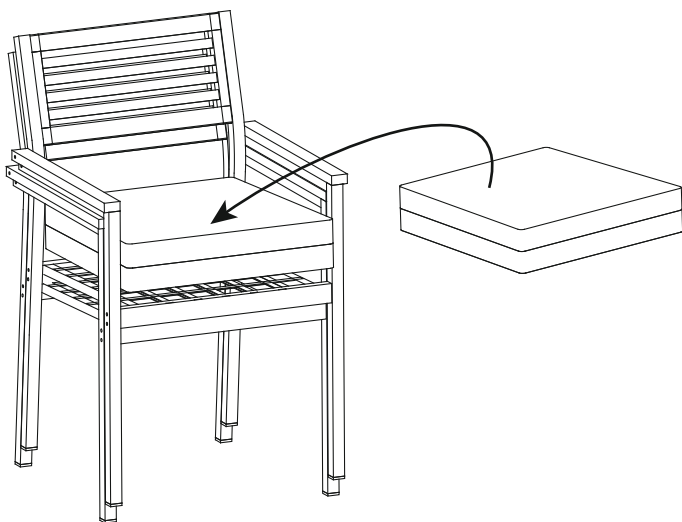



Return / Damage Claim Instructions

- ⚠ **DO NOT discard the box / original packaging.**
In case a return is required, the item must be returned in original box. Without this your return will not be accepted.
- ⚠ **Take a photo of the box markings.**
A photo of the markings (text) on the side of the box is required in case a part is needed for replacement. This helps our staff identify your product number to ensure you receive the correct parts.
- ⚠ **Take a photo of the damaged part (if applicable).**
A photo of the damage is always required to file a claim and get your replacement or refund processed quickly. Please make sure you have the box even if it is damaged.
- ⚠ **Send us an email with the images requested.**
Email us directly from marketplace where your item was purchased with the attached images and a description of your claim.



Instructions De Retour / Réclamation De Dommages

- ⚠ **NE PAS jeter la boîte/l'emballage d'origine.**
Dans le cas où un retour est requis, l'article doit être retourné dans sa boîte d'origine. Sans cela, votre retour ne sera pas accepté.
- ⚠ **Prenez une photo des marquages de la boîte.**
Une photo des marquages (texte) sur le côté de la boîte est requise au cas où une pièce serait nécessaire pour le remplacement. Cela aide notre personnel à identifier votre numéro de produit pour s'assurer que vous recevez les bonnes pièces.
- ⚠ **Prenez une photo des dommages (le cas échéant).**
Une photo des dommages est toujours requise pour déposer une réclamation et obtenir rapidement votre remplacement ou votre remboursement. Assurez-vous d'avoir la boîte même si elle est endommagée.
- ⚠ **Envoyez-nous un e-mail avec les images demandées.**
Envoyez-nous un e-mail directement depuis le marché où votre article a été acheté avec les images ci-jointes et une description de votre réclamation.



If you're having difficulty, our friendly customer team is always here to help.

