

CREALITY

Creality Laser Module Quick Start Guide Creality Laser Module 快速使用指南

V1.0



深圳市创想三维科技股份有限公司
SHENZHEN CREALITY 3D TECHNOLOGY CO., LTD.

3D打印产业布道者
3D Printing Evangelists

尊敬的用户：

感谢您选择创想三维的产品。为了您使用方便，请您在使用之前仔细阅读本快速使用指南，并严格按照快速使用指南的指示进行操作。

创想三维团队时刻准备为您提供优质的服务。在使用过程中无论遇到什么问题，请按照快速使用指南结尾所提供的电话、邮箱与我们进行联系。为了您能够更好地体验我们的产品，您还可以从以下方式获取设备操作知识：

随机使用说明：您可以在 TF 卡内找到相关使用说明及视频。

您还可以登陆创想三维官网 (www.cxsw3d.com) 寻找相关软硬件、联系方式、设备操作、设备保养等信息。

Dear Consumers:

Thank you for choosing our products. For the best experience, please read the instructions before operating the machine. Our teams always be ready to render you the best services. Please contact us via the phone number or e-mail address provided at the end when you encounter any problem .

For a better experience in using our product, you can also learn how to use the engraving machine in the following ways:

View the accompanied instructions and videos in the TF card.

Visit our official website www.creality.com to find relevant software/hardware information, contact details, operation and maintenance instructions.

固件升级

从 <https://www.creality.com/pages/download-cr-laser-falcon-laser-engraver> 下载最新固件，保存 bin 文件至 TF 卡根目录，并删除 TF 卡中的其它文件。断电状态下将 TF 卡插入控制盒的卡槽，机器通电自动更新。更新过程蜂鸣器会一直发出响声，响声结束则更新完成(期间不可断电)。

Firmware Upgrade

Download the latest firmware from <https://www.creality.com/pages/download-cr-laser-falcon-laser-engraver>, save the ".bin" file in the root directory of the TF card, back up any other files you need from the TF card then delete them, leaving only the firmware file on the card. Insert the TF card into the machine when it's powered off, then turn on the machine and it will update automatically. The buzzer will sound in the update process. When the update is completed, the sound will stop (do not power off in the update process).

使用安全须知

激光雕刻机在雕刻或切割材料时使用高密度激光束照射材料,使材料表面产生高温,目的是在不燃烧的情况下使材料气化。但大多数材料本质上是易燃的,可能被点燃并形成明火,明火可能烧毁机器及其周围环境。

请遵循以下操作原则:

1. 请勿将本产品放置在易燃易爆物品、挥发性溶剂或高热源附近,请将本产品放置在通风、阴凉、少尘的环境内。
2. 请勿在安装过程中使用其他产品电源线代替,请使用本产品附带的电源线。
3. 定期在断电的情况下,用干布清洁机身及激光模组。
4. 激光工作环境温度在 5°C-35°C,避免在潮湿环境下使用本产品,切勿在雷雨天气下使用本产品。
5. 如长时间不使用本产品,请关闭本产品,并断开电源线。
6. 本产品已连接电源时,请勿用手或其他工具触碰电子相关区域。严禁带电插拔激光模组线。
7. 本产品运行时,请勿触碰正在运动的机械机构及激光模组。
8. 务必在加工材料下方放置激光无法穿透的平面物体,如铝合金或不锈钢板。
9. 激光雕刻过程中,请务必佩戴护目镜,避免直视激光光斑带来的视力损伤。
10. 激光雕刻、切割过程中可能会产生少许烟雾或气味,建议在通风良好的环境下操作。
11. 严禁 10 岁以下的儿童在没有成人监督的情况下使用本产品,以免造成人身伤害。
12. 准备好灭火器备用,并定期维护和检查灭火器;
13. 激光模组工作时,严禁无人看管;
14. 使用者应遵守设备所在地(使用地)相应国家、地区的法律法规,恪守职业道德,注意安全义务,严禁将我司的产品或设备使用在任何非法用途上。如有违反,相关法律责任我司概不负责。

Safety Precautions

Using the high-density laser beam to heat up the workpiece surface when engraving or cutting aims to gasify without combustion. But most workpieces are essentially combustible, which may be ignited, leading to open fire and consequently to the machine breakdown and environmental contamination.

Please follow the following operating principles.

1. It is prohibited to store the machine in areas close to combustible and explosive substances, volatile solvents or source of heat. Instead, store it in a well-ventilated, cool and dust-free environment;
2. Make sure only use the provided power cord rather than other similar power cords during installation.
3. Regularly clean the body and laser module with a dry cloth when the power is off.
4. Ensure to run the laser at 0°C-35°C, it is prohibited to run the machine under a humidified environment or in thunderstorm weather.
5. Switch off the machine if it is going to be unused for an extended period of time, and unplug the power cord.
6. It is prohibited to come in contact with electronic areas with hands or other tools when the machine is connected to power supply; It is strictly forbidden to plug and unplug the power wires of the laser module under power.
7. Touching any moving parts and laser module while the machine is running is prohibited;
8. Be sure to place a laser-impenetrable flat object, such as an aluminum alloy or stainless steel plate, under the processing material.
9. Wear goggles to prevent vision damage arising from exposure to the laser spot during laser operation.
10. It is advisable to run the machine under a well ventilated environment as laser engraving may generate a small amount of fume or gas.
11. Children under age of 10 are not allowed to run the machine without adult supervision, which otherwise may lead to personal injury.
12. Prepare fire extinguishers in case of use, which shall be regularly checked.
13. It is prohibited to keep the machine unattended while it is running
14. Users should comply with the laws and regulations of the corresponding countries and regions where the equipment is located (used), abide by professional ethics, pay attention to safety obligations, and strictly prohibit the use of our products or equipment for any illegal purposes. Creality will not be responsible for any violators' legal liability under any circumstance.

产品参数 Parameters

产品名称 Product Name	Creality Laser module 1.6W	Creality Laser module 5W	Creality Laser module 10W
激光源 Laser Source	半导体激光器 semiconductor laser		
激光功率 Laser Power	1.6W	5W	10W
激光波长 Laser Wavelength	450±5nm	455±5nm	
净重 Net Weight	1.0kg	1.1kg	1.1kg
毛重 Gross Weight	1.3kg	1.4kg	1.4kg
输入电压 Input Voltage	100–240V~ 50–60Hz		
输出电压 Output Voltage	DC 24.0V 3.0A		
安全等级 Safety Level	Class IV(FDA 分类标准) Class IV (FDA classification standard)		
激光雕刻软件 Laser Engraving Software	LightBurn、LaserGRBL		
文件格式 File Format	jpeg, jpg, png, bmp, svg, dxf, etc.		
工作温度范围 Operating Temperature Range	0°C–35°C		
支持材料类型 Support Material Type	纸板、木板、竹板、橡胶板、皮革、织物、亚克力、塑料 Cardboard, wood, bamboo, rubber, leather, fabric, acrylic, plastic, etc.		
支持机器型号 Supported Printer Models	Ender–2 pro, Ender–3, Ender–3 pro, Ender–3 neo, Ender–3 max neo, Ender–3 s1, Ender–3 s1 pro, Ender–3 s1 max, Ender–3 V2, Ender–3 V2 neo, CR–10, CR–10 mini 等		

产品简介 Parts List

10W 激光模组线框图

10W laser module wireframe

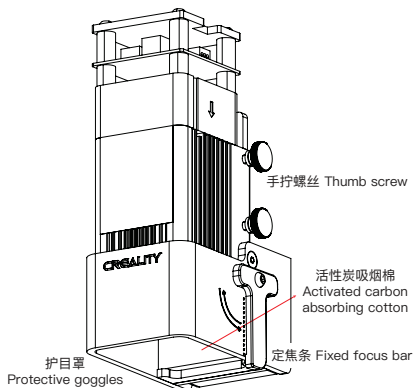
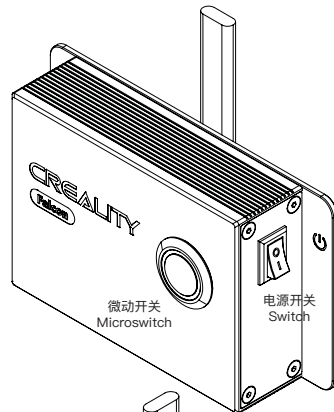
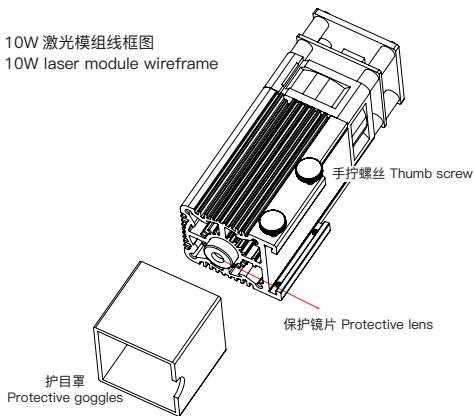

1.6W、5W 激光模组线框图

1.6W、5W laser module wireframes

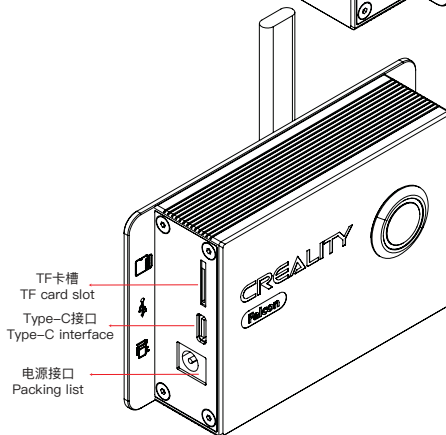

零部件清单 Parts List

1. 激光模组*1 1. Laser module*1	 <p>or</p>	8. 内六角扳手*1 8. Allen wrench*1	
2. 激光模组固定板*1 2. Laser module fixing plate*1		9. 多级定焦条*1 (仅限10W激光模组) 9. Multi-level fixed focus bar*1 (Only for 10W laser module)	
3. 控制盒组件*1 3. Control box kit*1		10. 黑色尼龙扎带*3 10. Black nylon cable tie*3	
4. Type-C数据线*1 4. Type-C data cable*1		11. TF卡&读卡器*1 11. TF card & card reader*1	
5. 内六角螺丝*1 5. Hexagon socket head screw*1		12. 无尘布*1 12. Cleaning cloth*1	
6. 黑色理线带*5 6. Black cable management belt*5		13. 防护眼镜*1 13. Protective goggles*1	
7. 快速使用指南*1 7. Quick start guide*1		14. 电源适配器*1 14. Power adapter*1	
		15. 电源线*1 15. Power cord*1	

组装说明 Assemble directions

以 Ender-3 V2 为例：

Take Ender-3 V2 as an example:

1. 从打印机上拔出 X 轴电机线、Y 轴电机线、X 轴限位开关线、Y 轴限位开关线 (Ender-3 v2、Ender-3 v2 neo、Ender-3 max neo 需要先拆卸 Y 轴限位开关保护罩,再进行接线);

1. Pull out the X-axis motor cable, Y-axis motor cable, X-axis limit switch cable, and Y-axis limit switch cable from the printer (Ender-3 v2, Ender-3 v2 neo, Ender-3 max neo need to remove the Y-axis limit switch protective cover before wiring).



拔出X轴电机线、X轴限位开关线
Pull out the X-axis motor cable and the X-axis limit switch cable



拔出Y轴电机线
Pull out the Y-axis motor cable



拆卸Y轴限位开关保护罩
Remove the Y-axis limit switch protective cover



拔出Y轴限位开关线
Pull out the Y-axis limit switch cable

2. 连接控制盒与打印机,注意排线上的 X、Y 标识; Z 对应激光模组线;

2. Connect the control box to the printer and pay attention to the "X" and "Y" labels on the cable. The "Z" corresponds to the laser module cable.



插入Y轴电机线
Insert the Y-axis motor cable



插入Y轴限位开关线
Insert the Y-axis limit switch cable



安装Y轴限位开关保护罩
Install the Y-axis limit switch protective cover



插入X轴电机线
Insert the X-axis motor cable

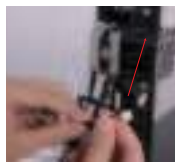

插入X轴限位开关线
Insert the X-axis limit switch cable

3. 调整 Z 轴高度;

3. Adjust the height of the Z axis;

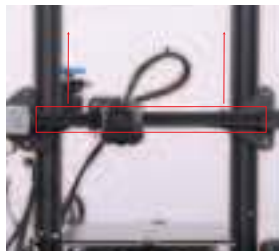

4. 安装激光模组固定板(安装时固定板应竖直), 锁紧螺丝;

4. Install the laser module fixing plate (It should be vertical) and lock the screw;



5. 安装激光模组, 使用两颗手拧螺丝锁紧, 并插上带有 Z 标识的激光模组线:

5. Install the laser module, use two thumbscrews to lock it, and plug in the laser module cable with "Z":

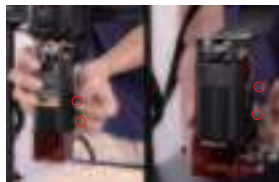

6. 使用扎带以及理线带整理排线；

6. Use cable ties and cable management belt to arrange the cables;



注意： Notes:

①.Ender-3 s1、Ender-3 s1 pro、Ender-3 s1 plus 的 Y 轴电机线需要侧绕，以防卡线。另安装激光模组固定板前需要先卸下喷头组件 (松开四颗螺丝即可)；

①.The Y-axis motor cable of Ender-3 s1, Ender-3 s1 pro, Ender-3 s1 plus needs to be placed on the side to prevent the cable from being pulled; Before installing the laser module fixing plate, you need to remove the extruder (loosen four screws);



- ②. Ender-3 neo, Ender-3 v2 neo, Ender-3 max neo 安装激光模组固定板时, 需要将其略微倾斜才能安装到合适位置;
- ②. For Ender-3 neo, Ender-3 v2 neo, and Ender-3 max neo, when installing the laser module fixing plate it needs to be slightly tilted before it can be installed in the suitable position;



- ③. 部分机器在雕刻过程中 Z 轴可能会下降, 您需要开启打印机或使用其它方式锁定 Z 轴;
- ③. The Z axis of some machines may move during engraving, you need to lock the Z axis by turning on the printer or in other ways;
- ④. 所有排线必须在机器断电状态下才能进行插拔。
- ④. All cables must be plugged and unplugged when the machine is powered off.

软件安装及使用 Software installation and usage guide

机器可通过 Type-C 数据线进行在线工作, 也可通过 TF 卡进行离线工作 (只能使用 LightBurn 生成雕刻文件)。详细的软件教程请参考 TF 卡中的随机资料。

The machine can be controlled through Type-C data cable, or offline through TF card (you can only use LightBurn to generate engraving files). For detailed software tutorials, please refer to the information in the TF card.

准备工作 Preparation

在开始雕刻前, 您需要完成以下准备工作:

Before starting to engrave, you need to complete the following preparations:

1. 再次仔细阅读使用安全须知中的内容。

1. Read the contents in the "Safety precautions" again carefully.

2. 确保激光模组的保护镜片干净, 并正确调节激光模组焦距。

2. Make sure the protective lens of the laser module is clean and adjust the focal length of the laser module correctly.

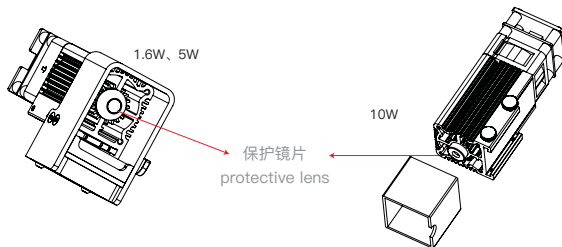

1.6W、5W 激光模组：定焦条自然垂直向下时应与雕刻材料表面互相接触, 最后使用右侧的手拧螺丝将其锁紧, 并顺时针拨动定焦条直至被磁铁吸住, 最后插上激光模组线。

1.6W、5W laser module: The fixed focus bar should contact with the surface of the processed material when it is naturally vertical downward. Finally lock it with two hand screws on the right and turn the fixed focus bar clockwise until it is attracted by the magnet. Finally plug in the laser module cord.

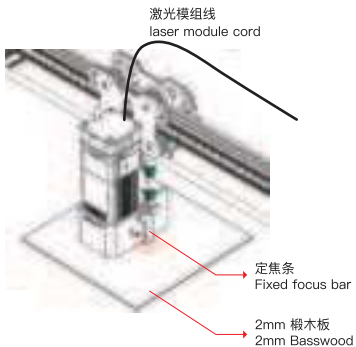

10W 激光模组：请将多级定焦条放置在模组与加工材料之间，按照定焦条表面的镗雕提示，使激光模组护目罩底部与多级定焦条对应位置相接触，最后使用右侧的手拧螺丝将其锁紧。例如雕刻或者切割 2mm 厚的椴木板或其它材料：

10W laser module: Please place the multi-level fixed focus bar between the laser module and the processed material. Follow the tips and make the bottom of the laser module contact with the corresponding surface of the multi-level fixed focus bar. Finally lock it with two hand screws on the right. For example, if you engrave or cut a 2mm basswood or other material:

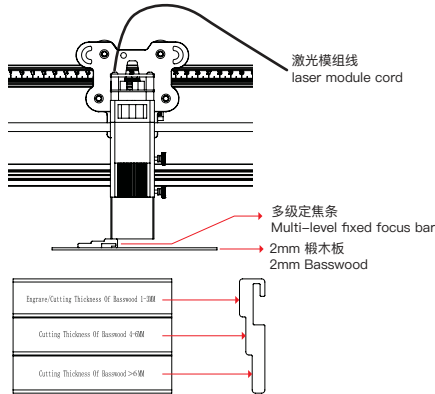

3. 修改 GRBL 配置参数。

3. Modify GRBL configuration parameters.

安装 LightBurn 软件，成功添加机器后，如果您机器的 X、Y 打印尺寸不是 220mm，则需要在控制台中修改 \$130、\$131 这两个配置参数，详情请参考 TF 卡“LightBurn 用户指南”。

Install the LightBurn software, after adding the printer successfully, if the X and Y axis of your printer is not 220mm, you need to modify the two configuration parameters of \$130 and \$131 in the console. For details, please refer to the TF card file "User manual for LightBurn".

配置参数 Configuration parameter 机器型号 Machine model	\$130	\$131
Ender-2 pro	165	165
Ender-3	220	220
Ender-3 Pro	220	220
Ender-3 neo	220	220
Ender-3 max neo	300	300
Ender-3 s1	220	220
Ender-3 s1 pro	220	220
Ender-3 s1 plus	300	300
Ender-3 V2	220	220
Ender-3 v2 neo	220	220
CR-10	300	300
CR-10 mini	300	220

在线工作 Online operation

通过 Type-C 数据线, 实时连接控制盒与软件, 详情请参考 TF 卡中的随机资料。注意: 在线工作时, 请不要插入 TF 卡, 不要按控制盒上的微动开关。

Connect the control box and use the software to operate the machine real time through the Type-C cable. For details, please refer to the information in the TF card. Note: When operating through Type-C, please do not insert the TF card, and do not press the micro switch on the control box.

离线工作 Offline working

1. 首先通过 LightBurn 软件生成雕刻文件 (.gcode/.gc/.g/.nc/.ngc), 将文件保存至 TF 卡的根目录中 (机器默认读取 TF 卡第一级目录中最新的雕刻文件, 建议删除第一级目录中其它雕刻文件), 上电前将 TF 卡插入机器。然后使用配套的电源适配器和电源线连接机器, 最后打开控制盒左侧的红色电源开关。

1. First generate the engraving file (.gcode/.gc/.g/.nc/.ngc) through LightBurn software, and save the file to the root directory of the TF card (the machine reads the engraving file with the latest system modification date in the root directory of the TF card by default. It is recommended to delete other engraving files in the root directory), insert the TF card into the machine before powering on. Then use the power adapter and power cord to connect the control box, and finally turn on the red power switch on the right side of the control box.

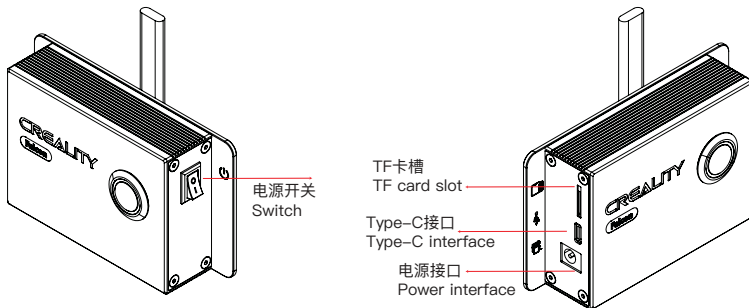

电源接通后, 机器发出“滴 ... 滴 ... 滴”三声, 机器进行初始化后进入待机模式, 指示灯变成呼吸灯效果。

After the power is turned on, the machine emits three beeps of "di...di...di", the machine enters standby mode after initialization, and the indicator light turns into a flashing light.

2. 按下微动开关, 机器从待机模式进入预览模式, 激光头会发出弱光, 并围绕所加工图片的最大 X、Y 边缘重复运动, 指示灯常亮。此时可以调整材料至合适位置。

2. Press the microswitch, it will enter preview mode from standby mode, the laser head will emit a weak laser, and repeat movement around the largest X, Y border of the processed engraving/cutting area with indicator light on. At this time, adjust the material to a suitable position.

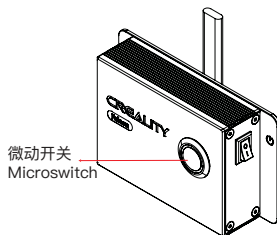

预览模式下,再次按下微动开关,机器进入雕刻模式,此时激光头会发出强光,机器开始雕刻,指示灯常亮。

如果需要暂停雕刻,请按下微动开关,此时指示灯变成呼吸灯效果,再次按下微动开关可以继续雕刻。

如果需要取消雕刻,请长按微动开关 3 秒,机器会发出“滴”一声,随后机器复位,复位完成机器发出“滴 ... 滴”两声,进入待机模式,指示灯变成呼吸灯效果。

In preview mode, press microswitch again, it will enter engraving mode. At this time, the laser head will emit a corresponding level of laser power, the machine will start engraving with indicator light on.

If you need to cancel the engraving, please press and hold the microswitch for 3 seconds, it will "beep" once, then it will return to home position, and "beep" twice after reset is completed. Enter standby mode, the indicator light returns into flashing light.

If you need to cancel the engraving, please press and hold the microswitch for 3 seconds, it will "beep" once, then it will return to home position, and "beep" twice after reset is completed. Enter standby mode, the indicator light returns into flashing light.

3. 雕刻完成后,机器会长“滴”三声,随后机器复位,复位完成机器发出“滴 ... 滴”两声,进入待机模式,指示灯变成呼吸灯效果。

3. After engraving is completed, it will "beep" three times and return to home position then it "beeps" twice, enters standby mode, and the indicator light turns into flashing light .

指示灯状态说明 Indicator Status

1. 指示灯灭: 机器处于断电状态,或上电异常。

2. 呼吸灯效果: 机器处于待机模式,可按下微动开关进入预览模式或雕刻模式。

3. 指示灯闪烁: 机器处于升级模式,同时蜂鸣器发出急促的响声,等待升级完成后自动进入待机模式。

4. 指示灯常亮: 机器处于预览模式或雕刻模式,此时激光头处于出光状态,需格外注意安全。

1. Light off: The machine is in a power-off state, or the power is abnormal.

2. Slow Flashing light: The machine is in standby mode, you can press the microswitch to enter preview mode or engraving mode.

3. Fast Light flashes: the machine is in upgrade mode, and the buzzer beeps quickly, and it will automatically enter standby mode after the upgrade is completed.

4. Light always on: the machine is in preview mode or engraving mode. The laser head is working, please pay attention to safety.

离线工作 Offline operation

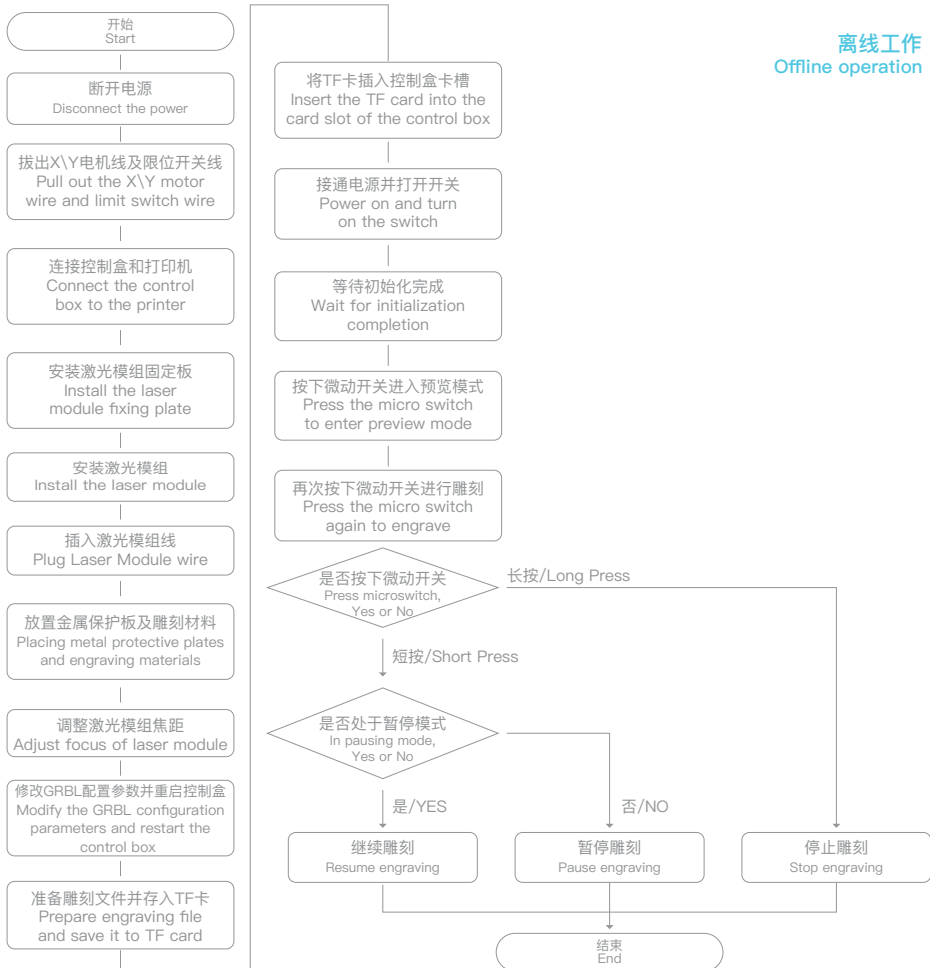





产品保修卡

产品寄回前请先联系售后专员，为正常进行售后处理，请务必填写此卡，并随机器寄回。

返修

换货

退货

客户名称：_____ 联系电话：_____ 故障描述或退、换货原因和建议：
收件地址：_____ _____
_____ _____
_____ _____
机器制造编码：_____ 订单编号：_____ 维修情况记录：
购买渠道：电商平台 线下 _____
购买日期：____年____月____日 _____

温馨提示：基本信息及返厂原因为客户必填项，维修情况记录部分为维修人员填写项。



WARRANTY

Before returning the product and filling in a warranty, please contact after-sale person for going through after-sale formality. And attach this warranty card along with the returned machine.

Repair

Change

Return

Name: _____ Telephone: _____ Malfunction And Damage Depiction Or Return
Address: _____ And Change Reasons\Suggestions:
_____ _____
_____ _____
Serial Number: _____ Order Number: _____ Repair Records:
Channel: Platform Offline _____
Date of purchase Day _____ Mon. _____ Year _____

Note: Client need filling in basic infor. and return reasons. Repair records shall retain for technicians.



※ 使用者应遵守设备所在地(使用地)相应国家、地区法律法规,恪守职业道德,注意安全义务,严禁将我司的产品或设备使用在任何非法用途上。如有违反者所应承担的相关法律责任我司概不负责。

※ 因每款机型不同,实物与图可能有所差异,请以实物为准,最终解释权归深圳市创想三维科技股份有限公司所有。

※ Users should abide by the laws and regulations of the country and region where the equipment is located (place of use), abide by professional ethics, and pay attention to safety obligations. It is strictly forbidden to use our products or equipment for any illegal purpose. Our company is not responsible for the relevant legal responsibilities that the violator should bear.

Since each model is different, the actual product may be different from the picture. Please refer to the actual product. The final interpretation right belongs to Shenzhen Chuangxiang 3D Technology Co., Ltd.

3D打印产业布道者 3D Printing Evangelists

以布道者的精神传递,让千家万户享受科技带来的便捷

With the spirit of evangelists, we want to share the convenience of technology with everyone.



深圳市创想三维科技股份有限公司

深圳市龙华区民治街道新牛社区梅龙大道锦绣鸿都大厦18F

公司网站: www.cxsw3d.com

服务热线: 400 6133 882

0755-8523 4565



SHENZHEN CREALITY 3D TECHNOLOGY CO.,LTD.

18F, JinXiuHongDu Building, Meilong Blvd., Longhua Dist., Shenzhen, China 518131

Official Website: www.creality.com

Tel: +86 755-8523 4565

E-mail: info@creality.com cs@creality.com