



# DAKE 10- & 20-Ton Floor/Bench Utility Press

## INSTRUCTIONAL MANUAL



(This is a F-20 model so there may be slight differences)



**WARNING!** Read and understand all instructions and responsibilities before operating. Failure to follow safety instructions and labels could result in serious injury.

Dake Corporation  
1809 Industrial Park Dr  
Grand Haven, MI 49417

Phone: 800.937.3253  
Fax: 800.846.3253

[www.dakecorp.com](http://www.dakecorp.com)  
[customerservice@dakecorp.com](mailto:customerservice@dakecorp.com)





## Table of Contents

DAKE Standard Limited Warranty.....	3
Return & Refund Policy.....	5
Specifications.....	7
Safety Warnings.....	8
Assembly Instructions: 10 Ton Bench Model .....	10
Assembly Instructions: 10 / 20 Ton Floor Model .....	12
Operation .....	14
How to Add Fluid to Hydraulic Pump:.....	15
Trouble Shooting.....	15
Gauge Conversions .....	16
Parts List.....	17
10 Ton Bench Press:.....	17
10 Ton Floor Utility Press: .....	19
20 Ton Floor Utility Press: .....	21
Order Information.....	23



## DAKE Standard Limited Warranty

### Finished Machines

- Dake warrants to the original purchaser the finished machine manufactured or distributed by it to be free from defects in material and workmanship under normal use and service within 1 year (12 months) from the delivery date to the end user.

### Parts

Dake warrants to the original purchaser the component part manufactured or distributed by it to be free from defects in material and workmanship under normal use and service within 30 days from the delivery date to the end user.

The standard limited warranty includes the replacement of the defective component part at no cost to the end user.

### Sale of Service (Repairs)

Dake warrants to the original purchaser the component part repaired by Dake Corporation at the manufacturing facility to be free from defects in material and workmanship under normal use and service within 90 days from the return date to the end user, as it pertains to the repair work completed. The standard limited warranty includes repair of the defective component part, at no cost to the end user.

### Warranty Process

Subject to the conditions hereinafter set forth, the manufacturer will repair or replace any portion of the product that proves defective in materials or workmanship. The manufacturer retains the sole right and option, after inspection, to determine whether to repair or replace defective equipment, parts, or components. The manufacturer will assume ownership of any defective parts replaced under this warranty.

All requested warranty claims must be communicated to the distributor or representative responsible for the sale. Once communication has been initiated, Dake Customer Service must be contacted for approval:

- Phone: (800) 937-3253
- Email: [customerservice@dakecorp.com](mailto:customerservice@dakecorp.com)

When contacting Dake, please have the following information readily available:

1. Model #
2. Serial #
3. Sales Order #

Purchasers who notify Dake within the warranty period will be issued a Case number and/or a Return Material Authorization (RMA) number. If the item is to be returned per Dake's request, the RMA number must be clearly written on the exterior packaging. Any item shipped to Dake without an RMA will not be processed.



### Warranty Exceptions

The following conditions are not applicable to the standard limited warranty:

- (a) Part installation or machine service was not completed by a certified professional, and is not in accordance with applicable local codes, ordinances, and good trade practices.
- (b) Defects or malfunctions resulting from improper installation or failure to operate or maintain the unit in accordance with the printed instructions provided.
- (c) Defects or malfunctions resulting from abuse, accident, neglect, or damage outside of prepaid freight terms.
- (d) Normal maintenance service or preventative maintenance, and the parts used in connection with such service.
- (e) Units and parts which have been altered or repaired, other than by the manufacturer or as specifically authorized by the manufacturer.
- (f) Alterations made to the machine that were not previously approved by the manufacturer, or that are used for purposes other than the original design of the machine.



## Return & Refund Policy

Thank you for purchasing from Dake! If you are not entirely satisfied with your purchase, we are here to help.

### Returns

All Dake manufactured / distributed machines, parts and couplings include a 30-day return option. These policies are valid from the date of final shipment to the end user.

To be eligible for a return, the item must be unused and in the same condition as received.

All requested warranty claims must be communicated to the distributor or representative responsible for the sale. Once communication has been initiated, Dake Customer Service must be contacted for approval:

Phone: (800) 937-3253

Email: [customerservice@dakecorp.com](mailto:customerservice@dakecorp.com)

Once the return request has been approved by Customer Service, a representative will supply a Return Material Authorization (RMA) number. The returned item must have the provided RMA number clearly marked on the outside packaging. Any item received without an RMA number clearly visible on the packaging will not be processed.

An RMA number can only be provided by the Dake Customer Service team and must be obtained prior to the return shipment.

### Refunds

Once the item has been received and inspected for damages, a representative will notify the requestor referencing the provided RMA number.

If the return is approved, a refund will be issued to the original method of payment, less a 20% restocking fee. The restocking fee may be waived if an order is placed at the time of return with like-value merchandise.

Transportation costs are the responsibility of the end user and will not be credited upon return approval.

Any item that is returned after the initial 30 days or has excessive/obvious use will not be considered for a full refund.



## **SAFEGUARDING THE POINT OF OPERATION**

### ANSI B11.2 – Hydraulic Power Presses

#### **Safety Requirements for Construction, Care and Use**

It is important that Dake press users have a clear understanding of their responsibility involving the care and use of their Dake hydraulic press, including point-of-operation safeguards. Dake strongly recommends that Dake press users obtain a copy of the current American National Standard Institute (ANSI) B11.2 standard, for a more complete understanding of their responsibilities.

ANSI B11.2 states the following, relative to point of operation safeguarding:

“Normally, only the employer (press user) can determine the requirements of the press productions system components, including the dies and methods for feeding. Therefore, the employer is ultimately responsible to designate and provide the point-of-operation safeguarding system”.

The standard also discusses additional responsibilities of the employer. Some of the key responsibilities are:

The employer is responsible for the safety, use and care of the hydraulic power press production system.

The employer is responsible to consider the sources of hazards for all tasks to be implemented on the hydraulic power press production system.

The employer is required to eliminate, or control identified hazards in the scope of their work activity.

The employer is responsible for the training of personnel, caring for, inspecting, maintaining, and operating hydraulic press production systems to ensure their competence.

The employer is responsible to provide and ensure that point-of-operation safeguarding is used, checked, maintained and where applicable, adjusted on ever production operation performed on a press production system.

A complete and current copy of the ANSI B11.2 standard can be obtained by contacting the following:

American National Standards Institute  
1430 Broadway  
New York, NY 10018



AMT – The Association for Manufacturing Technology  
 7901 Westpark Drive  
 Mclean, VA 22102

## Specifications

### Machine Specifications:

	<b>10 Ton Bench</b>	<b>10 Ton Floor</b>	<b>20 Ton Floor</b>
<b>Press Type</b>	Manual 10-ton Bench	Manual 10-ton Floor	Manual 20-ton floor
<b>Cylinder Type</b>	Single Acting	Single Acting	Single Acting
<b>Max. Press Capacity</b>	10 Ton	10 Ton	20 Ton
<b>Ram Diameter</b>	1- 1/2"	1- 1/2"	2"
<b>Ram Stroke</b>	6"	8"	8"
<b>Head Travel</b>	Left / Right of center	Left / Right of center	Left / Right of center
<b>Ram Travel Per Stroke</b>	1/8" approx.	1/8" approx.	3/16" approx.
<b>Width Between Uprights</b>	16-3/4"	16-3/4"	23"
<b>Width Between Channels</b>	3"	3"	4"
<b>Max. Ram to Table</b>	16"	38"	39"
<b>Overall Height</b>	36"	60"	74"
<b>Weight</b>	132 lbs.	149 lbs.	283 lbs.

- In the space provided record the serial number and model number of the machine. This information is only found on the black Dake tag. If contacting Dake this information must be provided to assist in identifying the specific machine.

**Model No:**

---

**Part No:**

---

**Serial No:**

---

**Date of Purchase:**

---

## Safety Warnings

### BEFORE USE, ALL SAFETY INSTRUCTIONS MUST BE READ

- Before the PRESS is used, the instruction manual with this machine must be read and understood. This manual offers safe operation instructions. Offered below are safety instructions designed for the press and general safety instructions that apply to most machinery.
- As will all machinery there are certain hazards involved with operation and use of the machine. Using the machine with respect and caution will considerably lessen the possibility or personal injury. However, if normal safety precautions are overlooked or ignored, personal injury to the operator may result.
- This machine was designed for certain applications only. We strongly recommend that this machine NOT be modified and/or used for any application other than for which it was designed. If you have any questions relative to its application DO NOT use the machine until you contact with us and we have advised, you

### Practice Safe Operation

- Keep hands out of point of operation.
- Never hold part while pressing.
- Always wear the eye protection.
- Clamp work piece or brace when pressing.
- Never place fingers in pin holes.
- Always use nose piece when pressing. Never press using the end of the ram, damage to ram or threads can occur.
- Never use a press that is not fastened securely to the floor or workbench.
- Always used table pins and accessories furnished with press.
- Always have firm footing when operating press.
- Do not use press if parts are damaged or missing. (Hoses, structural components)



**This is the safety alert symbol.** When you see this symbol on your press be alert to the potential for personal injury.

Employer is responsible to perform a hazard/PPE assessment before work activity.



WARNING: This product contains Nickel, a chemical known to the State of California to cause cancer. For more information go to [www.P65Warnings.ca.gov](http://www.P65Warnings.ca.gov)



Label Part # 300168



Label Part # 84399

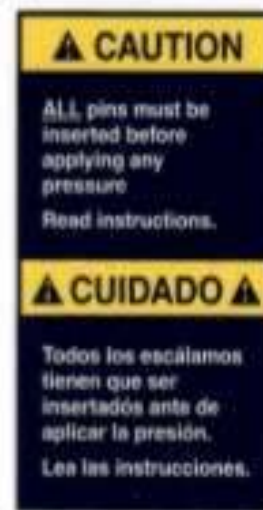

Label Part # 84487

Follow recommended precautions and safe operating practices.

<p><b>Carefully read all safety messages in these instructions and on your press safety signs.</b> Keep safety labels in good condition. Replace missing or damaged safety labels.</p>	<p><b>This machine is intended to be operated by one person.</b> This person should be conscious of the press ram movement not only for themselves but also for persons in the immediate area of the machine.</p>	<p><b>Under no circumstances increase the leverage ratio of the press by using a longer handle or by placing a pipe over the handle.</b> Never hammer on top of the ram.</p>
----------------------------------------------------------------------------------------------------------------------------------------------------------------------------------------	-------------------------------------------------------------------------------------------------------------------------------------------------------------------------------------------------------------------	------------------------------------------------------------------------------------------------------------------------------------------------------------------------------

## Assembly Instructions: 10 Ton Bench Model

### Step 1 (Bench Model Only):

- Using (2) M8 x 20mm bolts, nuts and washers install the union support to the bottom from of the upright channels. (Pump hanger bracket on the right-hand side of the upright.) The union support is to face outward. See drawing below.

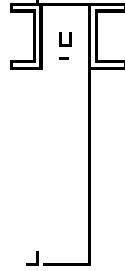
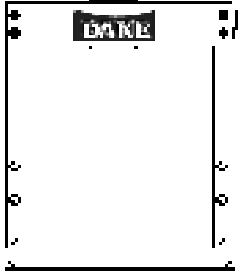

### Step 2:

- Carefully stand the unit upright. Making sure all components are square to each other, tighten all nuts and bolts securely.

### Step 3:

- Mount the head ram transverse plates. The side with two bars welded to them go inside the frame, with the threaded plate on the bottom. Using 10mm x 120 mm bolts, washers, and nuts, tighten only enough to allow plate to travel.

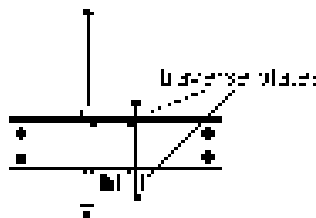

### Step 4:

- With press standing upright and all bolts tightened install the worktable. Insert two table pins in the two lowest holes.
- Take the worktable and tilt it at a sharp angle and insert it in the uprights.
- NOTE: The gussets welded to the table are at slight angles. The narrowest dimension of these gussets goes down. See drawing below for guidance. (Step 1) Once worktable is in the uprights turn it level and lower down and set it on the table pins. (Step 2)
- Take care when doing this, a helper would be advised.

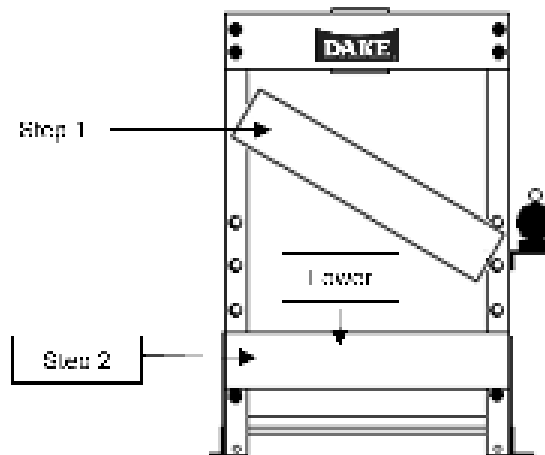
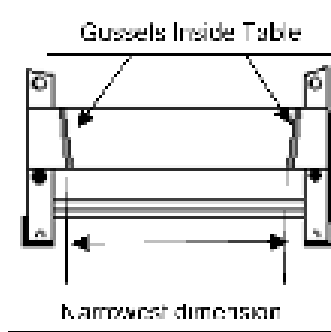

### Step 5:

- Locate the cylinder and remove the plastic protective cap on the end of the ram. (If applicable) Carefully screw the cylinder from the top into the head traverse ram plate. Screw this in as tight as possible while keeping the cylinder's hydraulic hose fitting facing to the right or pump side.
- NOTE: Cylinder may not be totally tight while keeping the fitting facing this way, but it will not affect the presses operation
- Using Teflon tape install the gauge to the top of the cylinder facing forward. When gauge and hose fittings is in correct position, install the spanner nut on the bottom of cylinder and snug up.

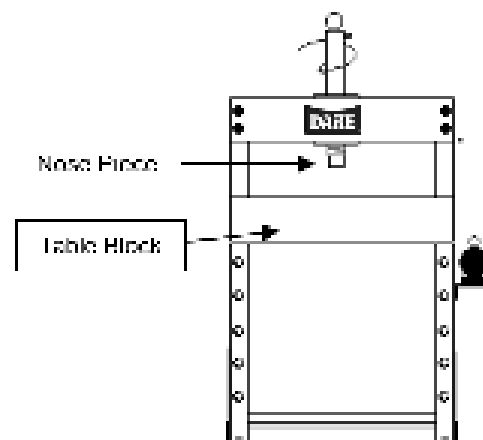

## Assembly Instructions: 10 / 20 Ton Floor Model

### Step 1:

- Install the union support to the inside of the upright channels and base angles, using the 4 of the M8 x 25mm bolts, nuts and washers provided.

### Step 2:

- Place union support in-between the channels and install the 2 base angles to the frame through the union support and install nuts. Base angles face outward (See drawing below) Hand tighten.

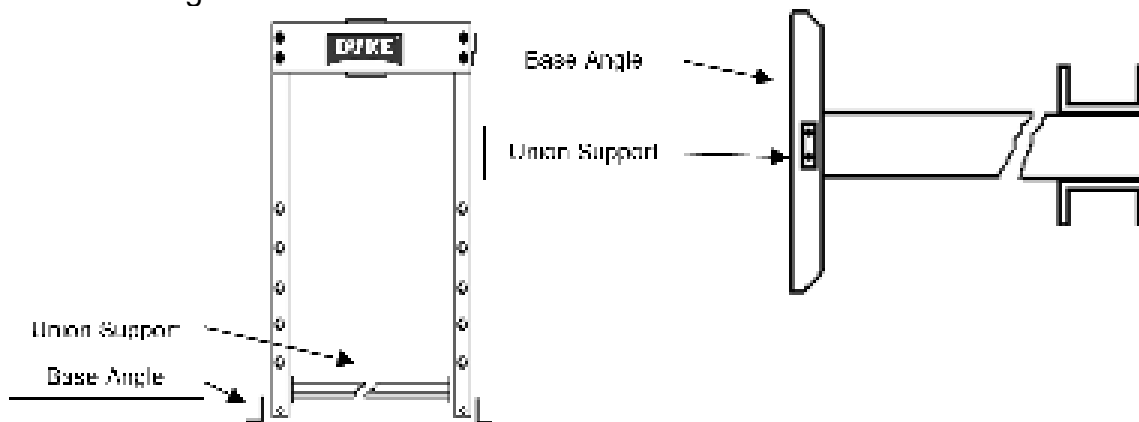

### Step 3:

- Carefully stand the unit upright. Making sure all components are square to each other, tighten all nuts and bolts securely.
- Install pump mounting plate on the side of the upright channel using the 3 M10 x 25mm bolts, nuts, and washers.

### Step 4:

- This step is installing the Mount Head Ram Traverse Plates. The side with two bars welded to the plate go inside the frame with the thick threaded plate on the bottom side

Step 5:

- Using two 10mm x 120 mm bolts, washers, and nuts, snug only enough to allow plate to travel.

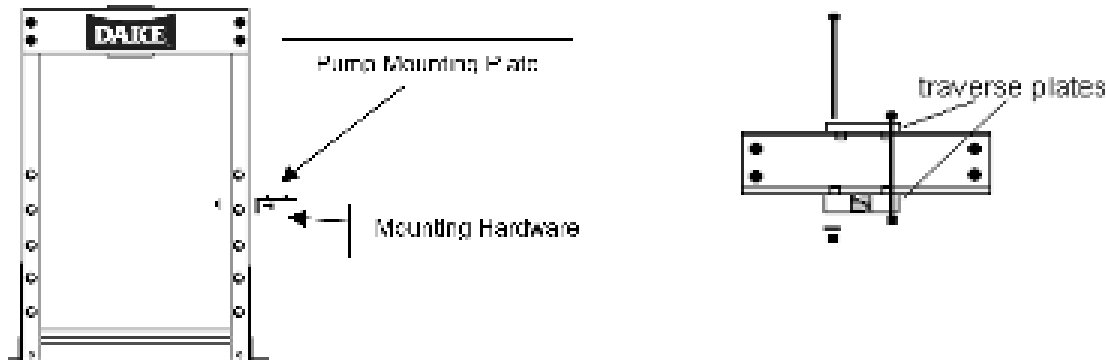

Step 6:

- Install the pumping device to the mounting plate using 2 M10 x 25mm bolts, nuts, and washers. Make sure pump is aligned in the center on this mounting plate for proper installation.

Step 7:

- With press standing upright and all bolts tightened install the worktable. Insert two table pins in the two lowest holes. Take the worktable and tilt it at a sharp angle and insert it in the uprights. (NOTE: The gussets welded to the table are at slight angles. The narrowest dimension of these gussets goes down. See drawing) (Step 1) Once worktable is in the uprights turn it level and lower down and set it on the table pins. (Step 2) Take care when doing this, a helper would be advised.

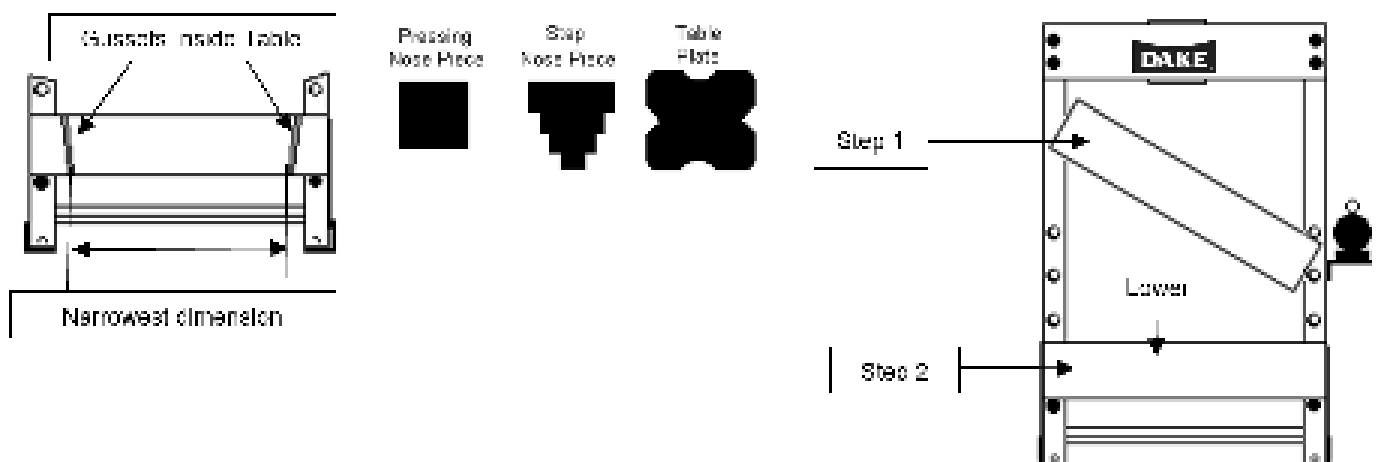

## Operation

### Procedure

- Always use the supplied nose pieces. The flat nose piece will be good for most pressing and flattening operations. The step style nose piece will work well for pressing bearing, bushing and parts that have a hole that the nose piece will fit into. This nose piece will help support or hold the piece during pressing operations.
- There are two table plates that should always be used as a backing plate during pressing operations. You will find notches in these table plates to allow you to use the press as a straightening press for axles, shafts, etc. and most round stock.
- When using your press always use the highest table setting to minimize the stroke distance of the ram.

**NOTE:** Only use supplied table pins. Do not weld or pin table.

- Once a part is put in the press and is clamped or braced securely, close the pumping unit release valve handle. (Clockwise).
- Pump the handle to lower the ram. Pump until pressing operation is completed. If you need to maintain pressure leave the valve on the pumping unit closed.
- When operation is complete, turn the valve counterclockwise to release pressure and raise the ram. Once the ram has been raising just above the work close valve again and repeat operation on the next part. There is no need to raise the ram all the way to the top each time.
- If pressing application requires a certain tonnage, press until the gauge reads the appropriate tonnage then stop. Release pressure and repeat operation.

**NOTE:** Never pump the ram down fully and dead head the ram in the cylinder. Only build pressure when using the table plates or a part is being pressed. Failure to do this may cause ram seal damage and leaking.

- If the application requires off center pressing, loosen the head ram traverse plate bolts and slide head left or right to the area where pressing is required. You may now proceed with the operation. When head is returned to the center position snug these bolts up to prevent unexpected movement.

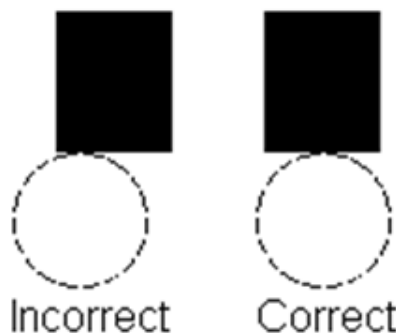
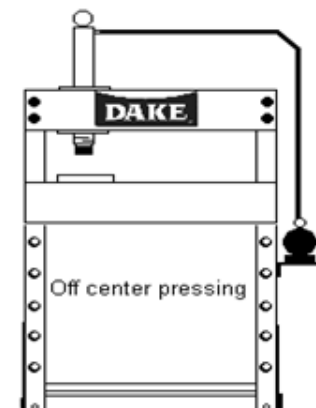

Always make sure that the center of the ram is in contact with the center of the part. If not, this can cause serious injury by projectile of part, or damaging the ram.



### How to Add Fluid to Hydraulic Pump:

1. Retract the ram that is connected to the pump.
2. Place the pump on a smooth, level surface so that that handle is in the up position.
3. Remove filler plug (small plug near the top).
4. Lift the plug end of the pump  $\frac{3}{8}$  to  $\frac{3}{4}$  of an inch off the ground to properly fill the reservoir.
5. Replace the plug to ensure quality sealing.
6. Reinstall pump on press.
7. Open the valve and pump continuously to properly bleed the system.

## Trouble Shooting

### Oil leaking around the ram?

Using the table plates secure the ram under pressure (4-6 ton) for 1 hour. This will put pressure on the main seal causing it to stretch and properly seal. If this does not work the seals more than likely need to be changed. Press may lose pressure during the 1-hour time period,

### Ram is jerky or sluggish?

With the valve open, repeatedly pump the handle to allow air to be released from the lines. If this does not work may need to replace the O-rings and seals in the pump.

### Ram does not return to the starting position at the top of the stroke?

Open and close the valve multiple times. If no progress has been made, the return spring may be broken and in need of replacing.

### What should I do if the pump will not build pressure?

Check and see if the release valve is in the closed position. Check oil fluid level. If low, add fluid and bleed to maximize efficiency. May need to change the O-rings and seals in the pump.

### My pressure gauge on the press is leaking?

Apply thread sealer (Teflon Tape) following the flow of the threads on the gauge. Do not apply Teflon Tape against the direction of the threads, this will not allow the gauge to seal properly.

### Leaking oil around the hoses?

Make sure to check all fittings. Tighten if they are loose, and check for any damage on the hose itself.

### The press will not reach the maximum allowable tonnage?

Check the valve to make sure it is fully in the closed position. You may have to bleed the system to maximize efficiency. May need to replace the seals in the head and the pump.

### The press will not hold pressure?

Check the valve and make sure it is in the closed position. Some cases, press will naturally bleed itself. If not, bleed the system. Important: the press itself is not designed to hold pressure for any amount of time. The press is designed to create pressure up to 10 tons and then retract.



## Gauge Conversions

### 10 Ton:

<b>10 Ton</b>		
45MM Bore = 1.77 Inch Bore		
<u>Tons</u>	<u>Bar</u>	<u>PSI(lbs/in<sup>2</sup>)</u>
1	55	799
2	110	1598
3	165	2397
4	220	3196
5	275	3996
10	551	7992

### 20 Ton:

<b>20 Ton</b>			
65MM Bore = 2.56 Inch Bore			
<u>Tons (1-10)</u>	<u>PSI (lbs/in<sup>2</sup>)</u>	<u>Tons (11- 20)</u>	<u>PSI (lbs/in<sup>2</sup>)</u>
1	388.86	11	4277.51
2	777.73	12	4666.38
3	1166.59	13	5055.25
4	1555.46	14	5444.11
5	1944.32	15	5832.97
6	2333.19	16	6221.84
7	2722.06	17	6610.70
8	3110.92	18	6999.57
9	3493.78	19	7388.43
10	3888.65	20	7777.30

## Parts List

### 10 Ton Bench Press:

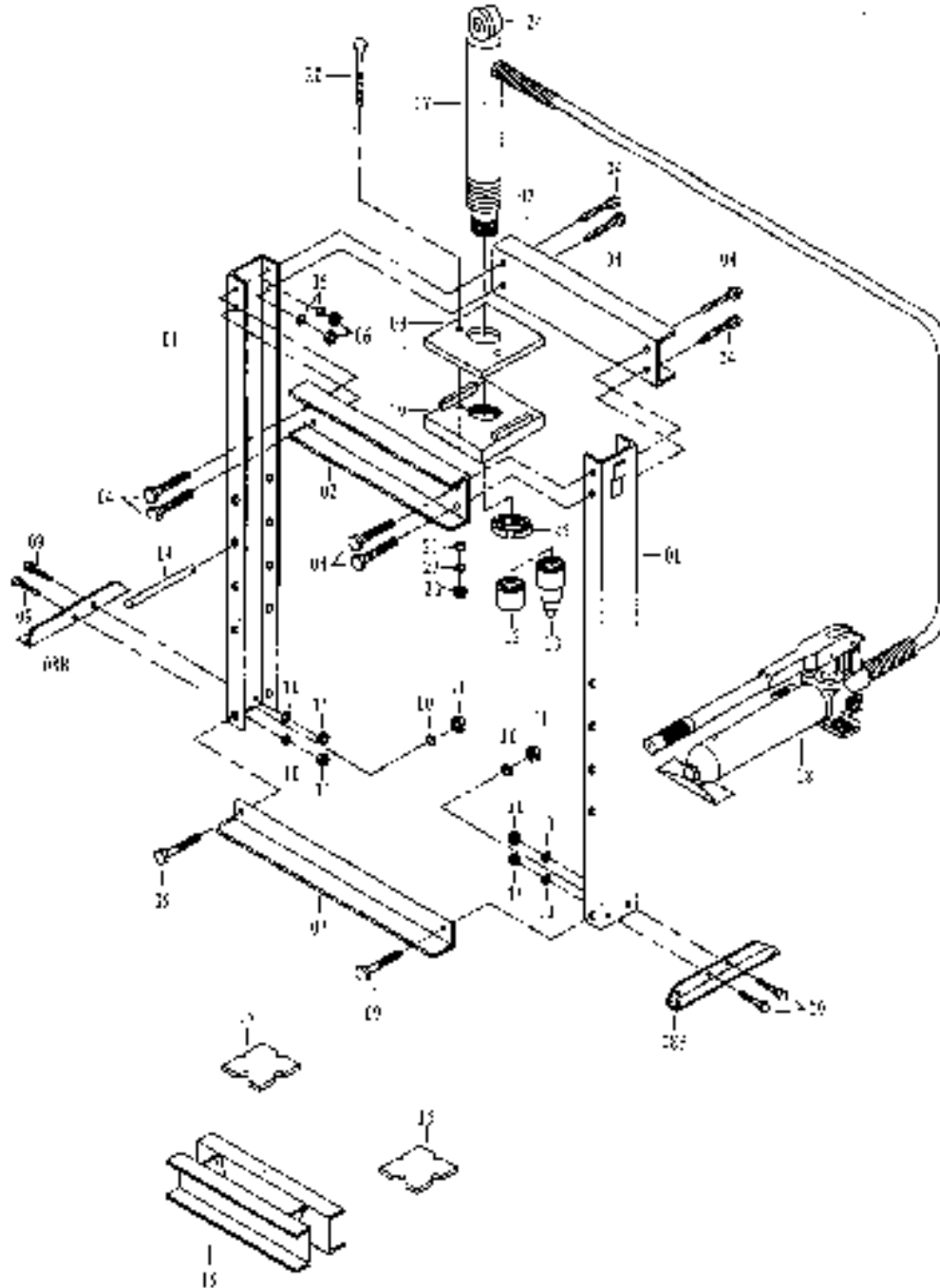



<b>10 Ton Bench Press Parts List</b>			
<b>Ref #</b>	<b>Part #</b>	<b>Description</b>	<b>Quantity</b>
1	301139	Frame Upright Channel	2
2	301138	Head Frame Channel	2
3	301137	Head Ram Traverse Plate	1
4	301136	Bolt M12 x 110mm	6
5	301135	Lock washer 12mm	6
6	301134	Nut M12 x 4	6
7	301132	Union Support	1
8	301131	Base Angle	2
9	301130	Bolt M8 x 20	6
10	301129	Lock Washer 8mm	6
11	301128	Nut M8	6
12	301127	Flat Nose Piece	1
13	301126	Step Nose Piece	1
14	301125	Table Pin	2
15	301124	Table Plate	2
16	301123	Worktable	1
17	301122	Ram / Cylinder	1
17A	302382	Cylinder Spring	1
18	301121	Pump Unit	1
19	301133	Head Ram Traverse Plate	1
20	301150	Bolt M10 x 140	2
21	302277	Washer 10mm	2
22	301149	Lock Washer 10mm	2
23	301141	Nut 10mm	2
24	302019	Gauge (Original)	1
25	302276	Ring	1

<b>Items Not Shown</b>	
<b>Part #</b>	<b>Description</b>
302318	Cylinder Seal kit
302382	Spring for cylinder
302310	Fitting Nipple
302309	Fitting Coupler
302554	Pump repair kit
302508	Hydraulic hose w/Coupling
302019	10 Ton Gauge
302019C	10 Ton Certified Gauge
302596	0-5000lbs. Gauge
302777	Max Hand Gauge 1-10 Ton

10 Ton Floor Utility Press:

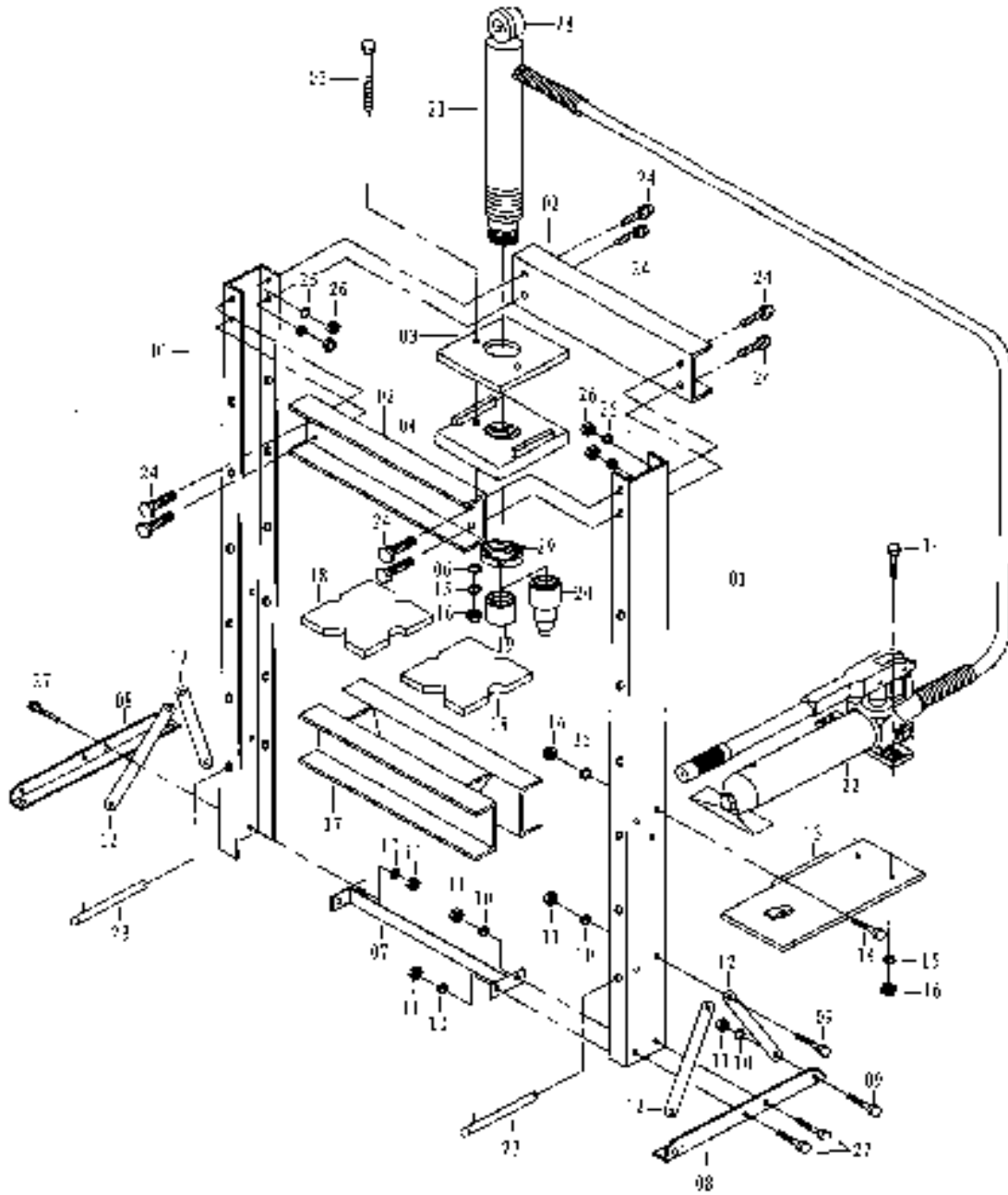



<b>10 Ton Floor Press Parts List</b>			
<b>Ref #</b>	<b>Part #</b>	<b>Description</b>	<b>Quantity</b>
1	301154	Frame Upright Channel	2
2	301153	Head Frame Channel	2
3	301152	Head Ram Traverse Plate (Upper)	1
4	301151	Head Ram Traverse Plates (Lower)	1
5	301150	Bolt M10 x 120mm	2
6	301149	Lock Washer 10mm	2
7	301148	Union Support	1
8	301147	Base Angle	2
9	301146	Bolt M8 x 25	12
10	301129	Lock Washer 8mm	12
11	301128	Nut M8	12
12	301145	Angle Support Strap	4
13	301144	Pump Support Bracket	1
14	301143	Bolt M10 x 25	5
15	301142	Lock Washer 10mm	4
16	301141	Nut M10	4
17	301123	Worktable	1
18	301124	Table Plate	2
19	301127	Flat Nose Piece	1
20	301126	Step Nose Piece	1
21	301140	Ram / Cylinder	1
21A	302383	Cylinder Spring	1
22	301121	Pumping Unit	1
23	301125	Table Pin	2
24	301136	Bolt M12 x 110mm	4
25	301135	Lock Washer 12mm	4
26	301134	Nut M12	4
27	302274	Bolt M8 x 25	4
28	302019	Gauge (Original)	1
29	302275	Ring	1
<b>Additional Parts Not Shown</b>			
<b>Part #</b>	<b>Description</b>		
302318	Seal Kit		
302383	Cylinder Spring (21A)		
302310	Fitting Nipple		
302309	Fitting Coupler		
302554	Pump Repair kit		
302508	Hydraulic Hose w/Coupling		
302019	10 Ton Gauge		
302019C	10 Ton Certified Gauge		
302596	0-5000lbs. Gauge		
302777	Max Hand Gauge 1-10 Ton		

20 Ton Floor Utility Press:

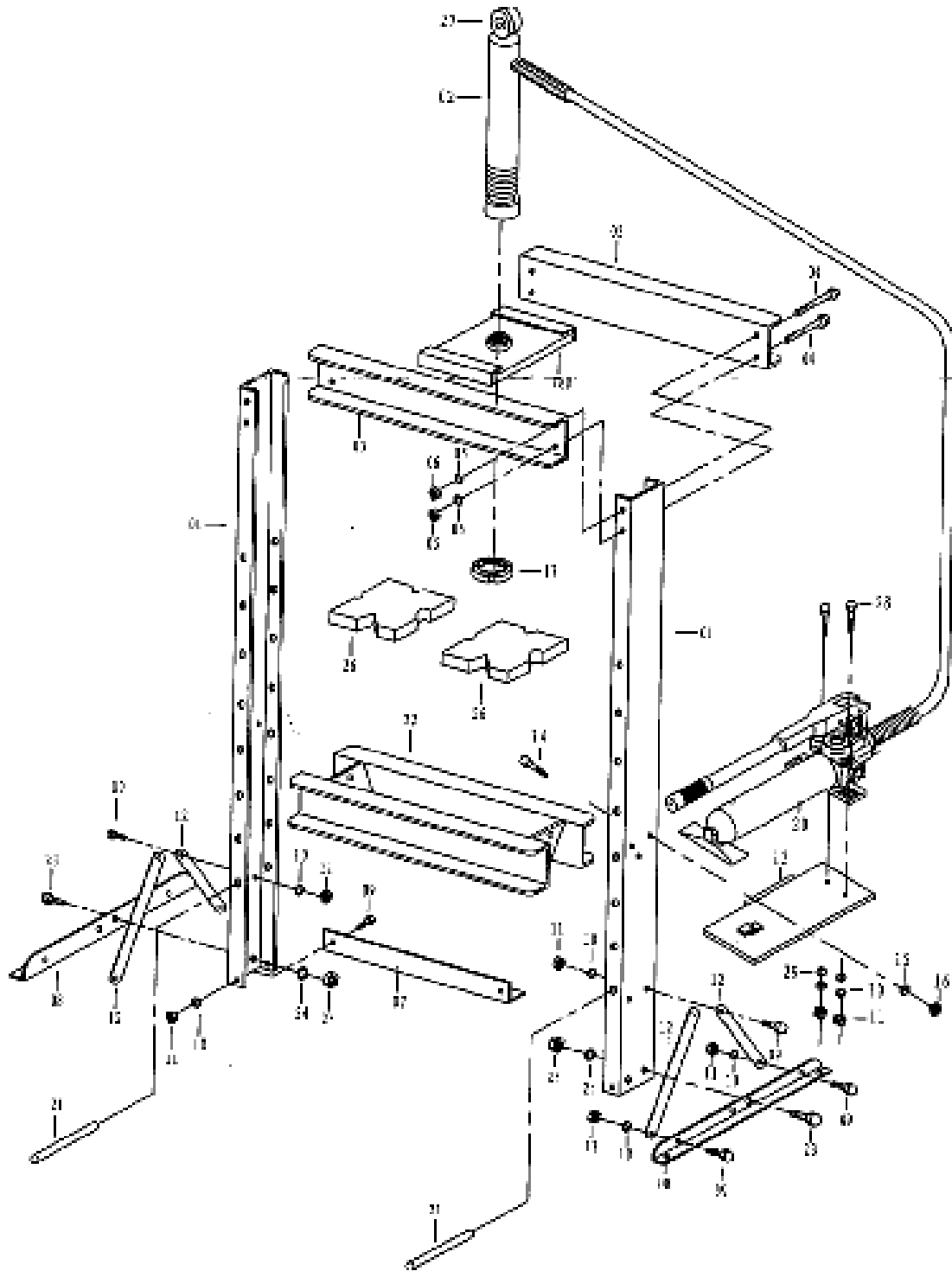



<b>20 Ton Floor Press Parts List</b>			
<b><u>Ref #</u></b>	<b><u>Dake Part #</u></b>	<b><u>Description</u></b>	<b><u>Quantity</u></b>
1	303183	Frame Upright Channel	2
2	303184	Ram Cylinder	2
3	303208	Head Frame Channel	2
4	303204	Bolt M18 x 140mm	4
5	303203	Lock Washer 18mm	4
6	303205	Nut 18mm	4
7	303186	Union Support	1
8	303207	Base Angle	2
9	301146	Bolt M8 x 25mm	10
10	301129	Lock Washer 8mm	12
11	301128	Nut 8mm	12
12	301145	Angle Support Strap	4
13	301144	Pump Support Bracket	1
14	301143	Bolt M10 x 25mm	3
15	301142	Lock Washer 10mm	3
16	301141	Nut 10mm	3
17	303187	Spanner Nut	1
18	303202	Head Traverse Plate	1
20	303192	2 Stage Pumping Unit	1
21	303194	Table Pin	2
22	303197	Table	1
23	78754	Bolt M12 x 30mm	4
24	301135	Washer 12mm	4
25	301134	Nut 12mm	4
26	303193	Pressing plates	2
27	303198	Gauge	1
28	78786	Bolt M8 x 30mm	2
29	303206	Washer 8mm	2

<b>Items Not Shown</b>	
<b><u>Part #</u></b>	<b><u>Description</u></b>
303199	Seal Kit
303200	Cylinder Spring
302508	Fitting Nipple
302309	Fitting Coupler
303201	Pump Repair Kit
302508	Hydraulic Hose w/Coupling
303191	Flat Nose Piece
303190	Stepped Nose Piece



## Order Information

- *Please contact factory for current prices*
- Parts are available for direct purchase from Dake or through a distributor. When placing a parts order, you will need to provide the part number, name of part, and model number. All parts shipped F.O.B. Factory in Grand Haven, MI.
- If a customer has any questions or concerns regarding a Dake product that was purchased, please email customer service at [customerservice@dakecorp.com](mailto:customerservice@dakecorp.com)