

Operating Guide

AME 140X

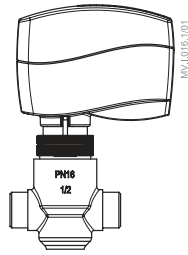

AME 140X +
VZ 2, VZL 2

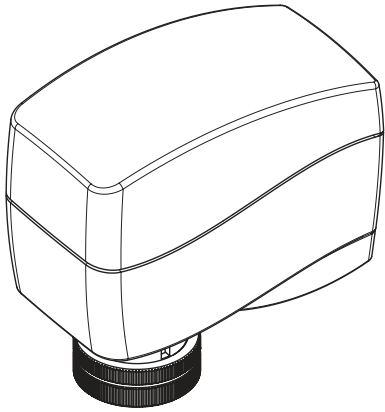
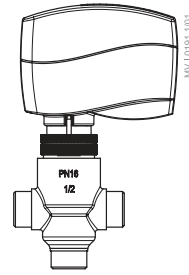

AME 140X +
VZ 3, VZL 3

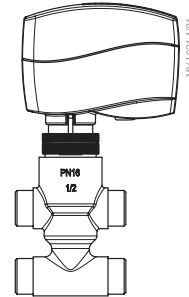

AME 140X +
VZ 4, VZL 4

AME 140X

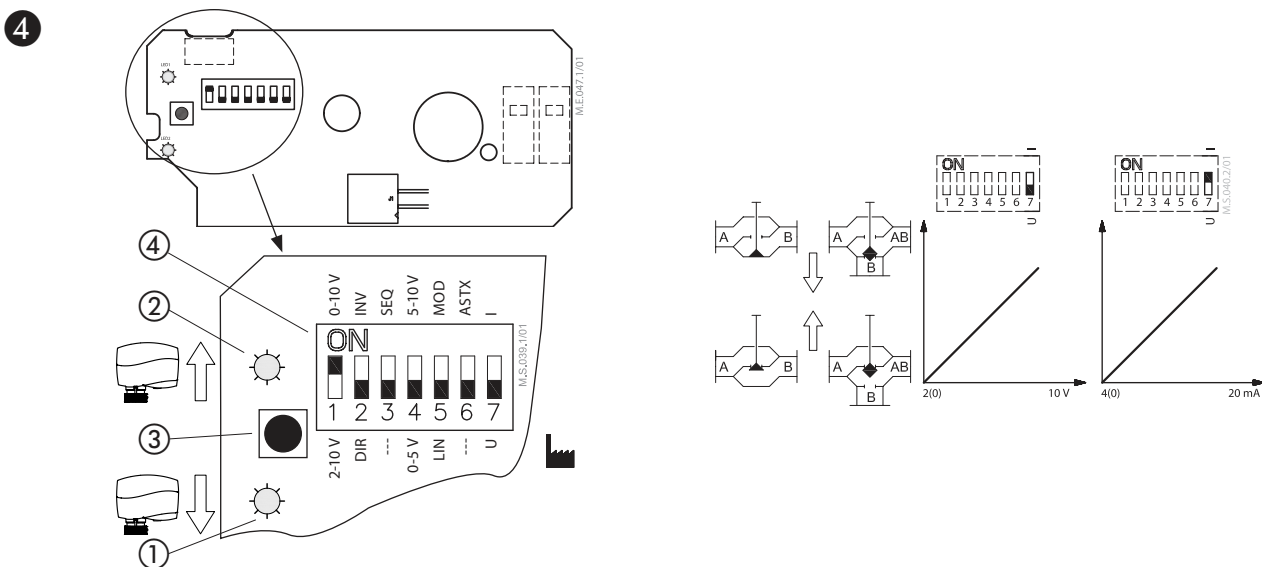
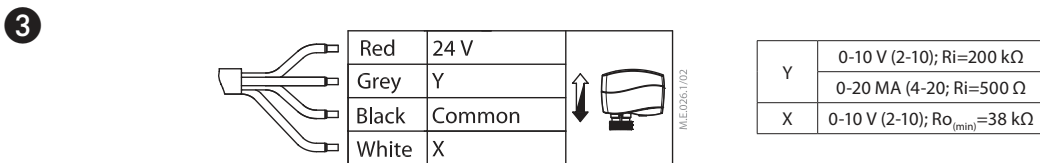
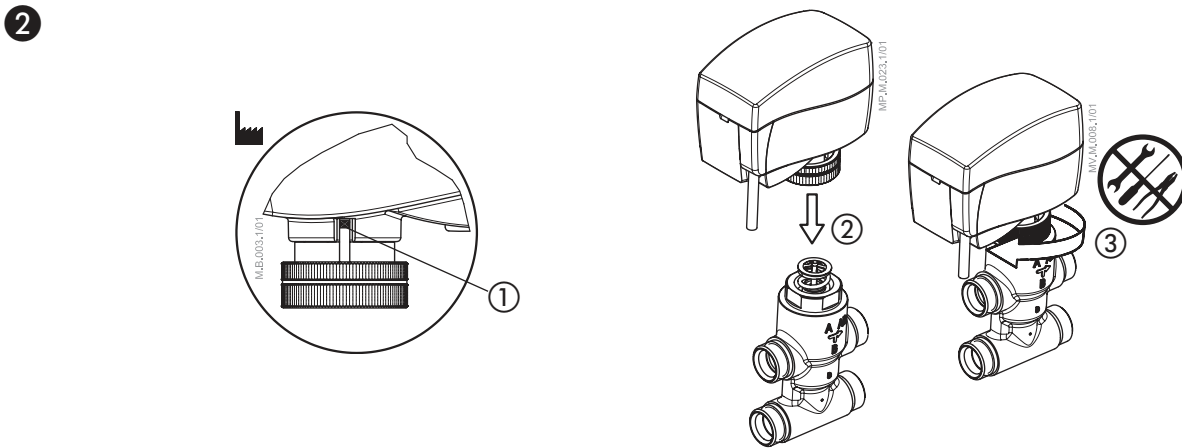
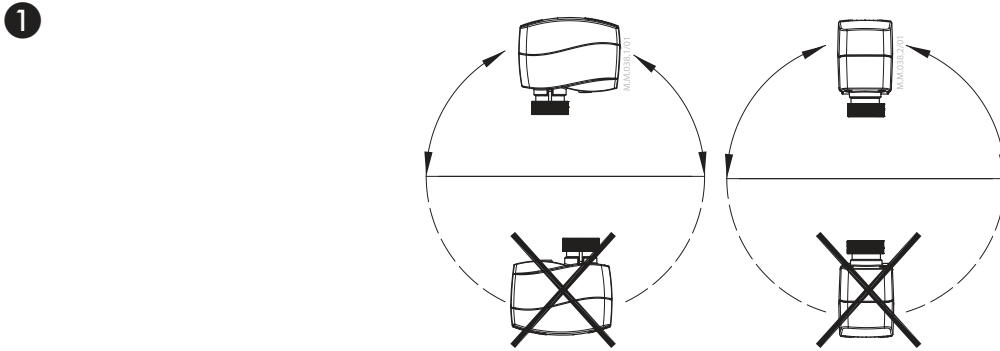

AME 140X

4

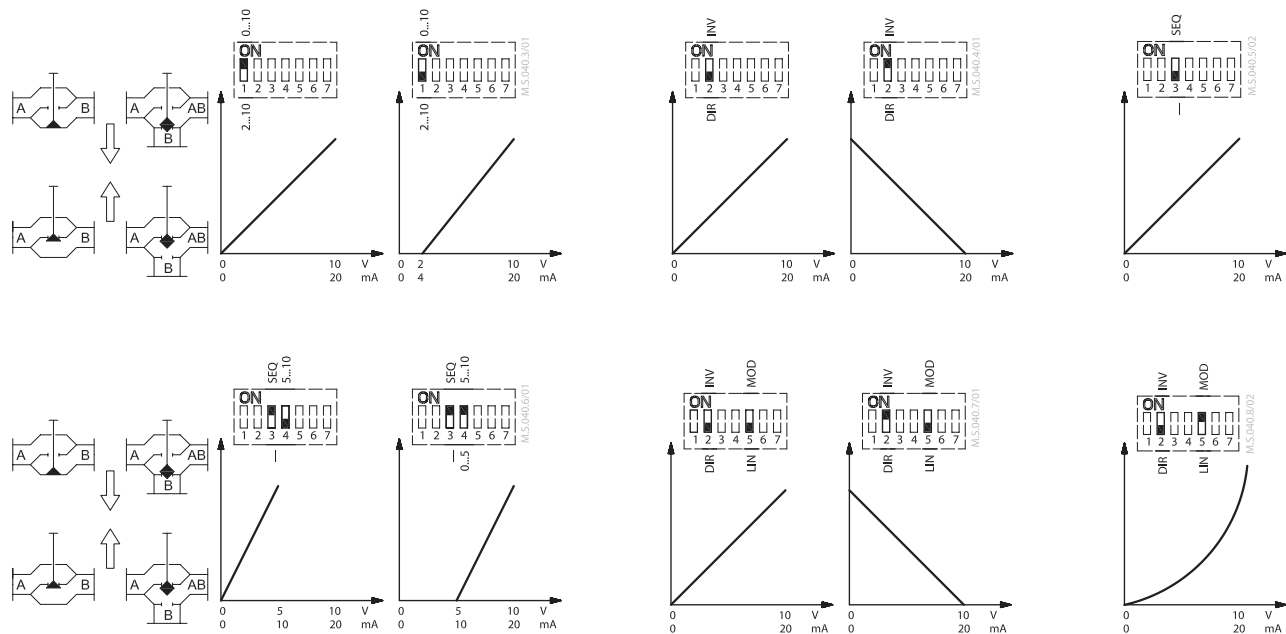

5

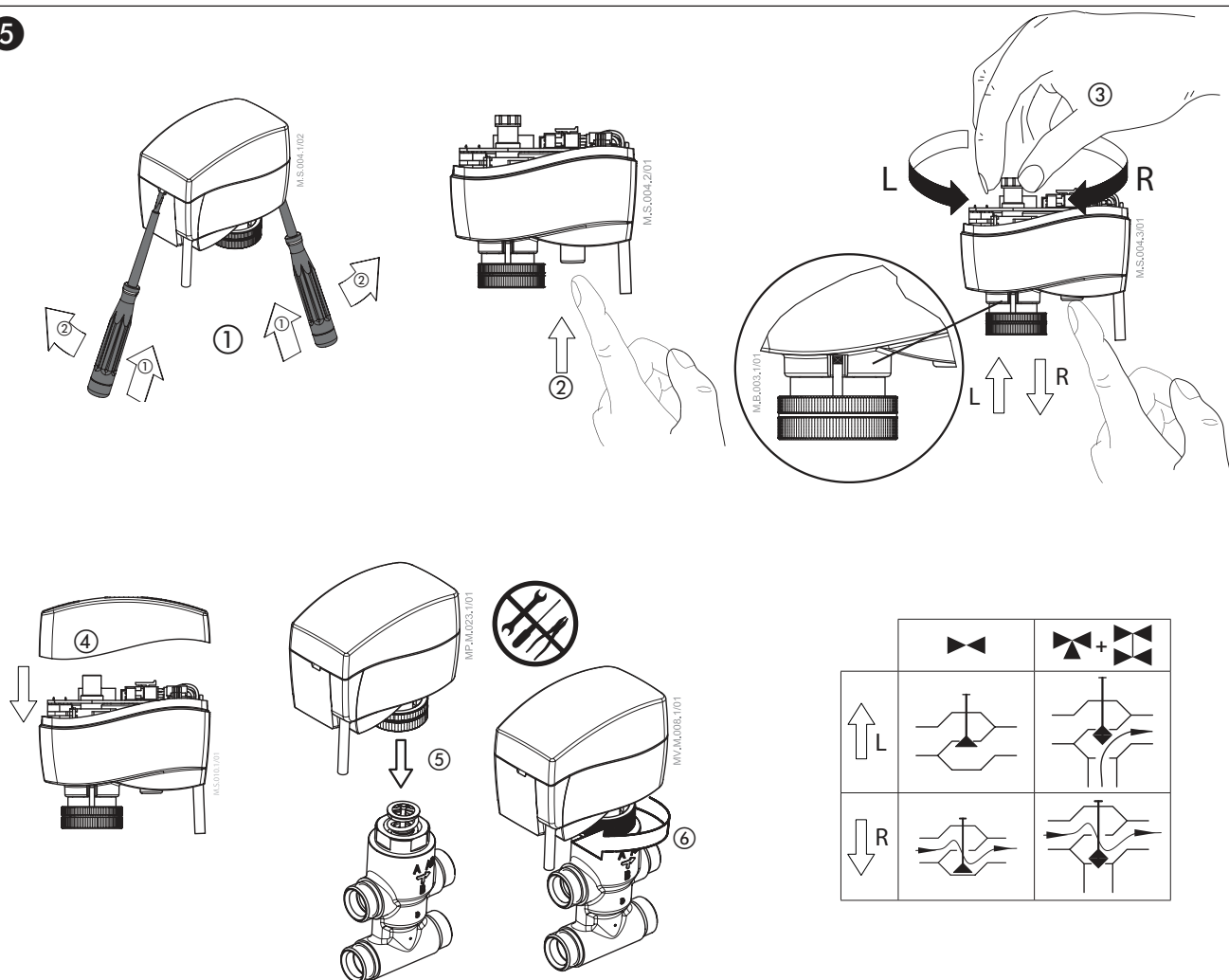

AME 140X

6	LED	Indication type	Operating mode
Green		Constantly lit	Positioning mode - Actuator is retracting the stem
		Constantly lit	
		Constantly lit	Positioning mode - Actuator is extracting the stem
		Constantly lit	
		Flashing (1 s cycle)	Self stroking mode - Actuator is retracting the stem
		Flashing (1 s cycle)	
	Flashing (1 s cycle)	Self stroking mode - Actuator is extracting the stem	
	Flashing (1 s cycle)		
Yellow		Constantly lit	Stationary mode - Actuator has reached upper end position (retracted stem)
		Constantly lit	
		Constantly lit	Stationary mode - Actuator has reached bottom end position (extracted stem)
		Constantly lit	
	Flashing (2.5 s cycle)	Stationary mode	
	Flashing (2.5 s cycle)		
Red		Flashing (1 s cycle)	Error Mode
Dark	No indication		No power supply

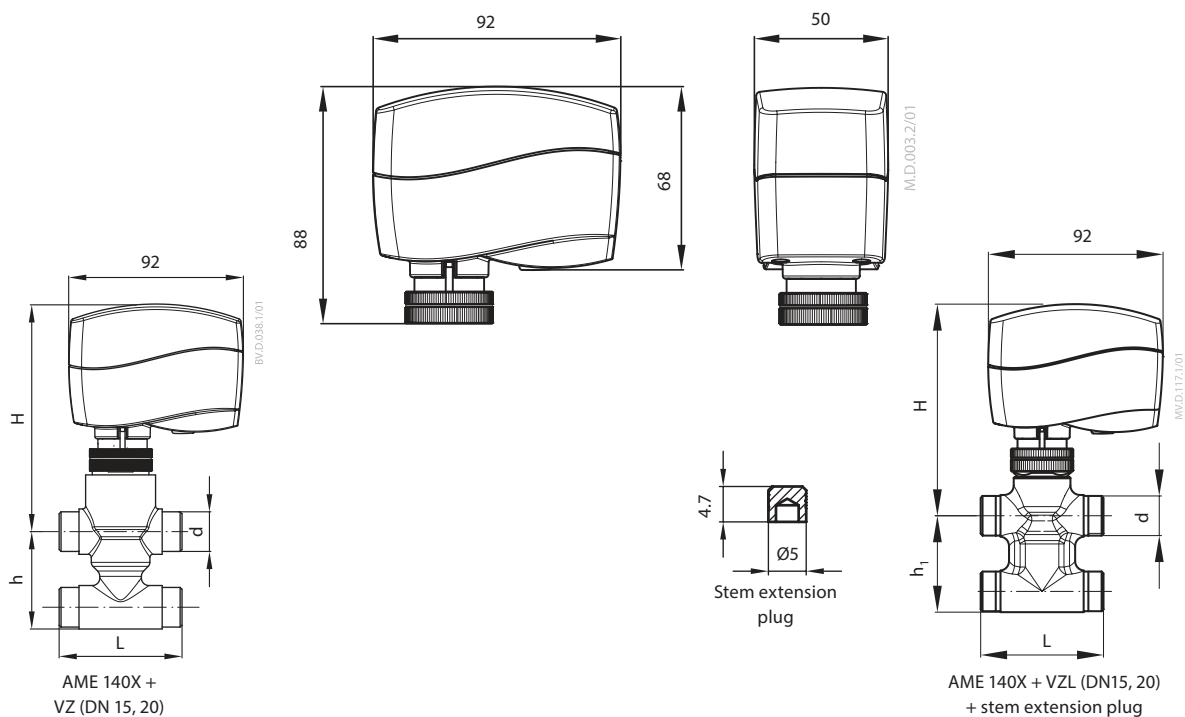
7

Valve type	d	mm			
		L	H	H ₁	h
VZ 2 / DN 15	G 1/2"	65	119	125	26.5
VZ 2 / DN 20	G 3/4"	77			
VZ 3 / DN 15	G 1/2"	65			35
VZ 3 / DN 20	G 3/4"	77			
VZ 4 / DN 15	G 1/2"	65	65		
VZ 4 / DN 20	G 3/4"	77			

Valve type	d	mm			
		L	H	H ₁	h ₁
VZL 2 DN 15	G 1/2"	65	111	117	29.5
VZL 2 DN 20*	G 3/4"	77	117	123	34.0
VZL 3 DN 15	G 1/2"	65	111	117	35.0
VZL 3 DN 20	G 3/4"	77	117	123	35.0
VZL 4 DN 15	G 1/2"	65	111	117	51.0
VZL 4 DN 20*	G 3/4"	77	117	123	65.0

*conex valves DN 20 - G 1 1/8" 14 TPI

ENGLISH

Safety Notes



To avoid injury of persons and damages to the device, it is absolutely necessary to read and observe these instructions carefully.

Necessary assembly, start-up, and maintenance work must be performed by qualified and authorized personnel only.

Please comply with the instructions of the system manufacturer or system operator.



Do not remove the cover before the power supply is fully switched off.



AC24 V
Connect via safety isolating transformer.

Disposal instruction



This product should be dismantled and its components sorted, if possible, in various groups before recycling or disposal.

Always follow the local disposal regulations.

Mounting ①

The actuator should be mounted with the valve stem in either horizontal position or pointing upwards.

Installation ②

- Check the valve neck.
- The actuator should be in steam up position (factory setting) ①.
- Ensure that the actuator is mounted securely on the valve body ②, ③.
The actuator is fixed to the valve body by means of a ribbed nut which requires no tools for mounting. The ribbed nut should be tightened by hand.
- Wire the actuator according to the wiring diagram ③.
- The direction of stem movement can be observed on the position indicator ①.

Auto sleep mode

1. If actuator is not mounted to the valve but connected to the power supply, it will first run to its extracted end position (buzz noise from the motor will appear). This behavior will last for max 3 minutes when power supply will be automatically cut off from electro motor and LED indicators.

2. It is mandatory to drive the spindle of the actuator to upper position before it will be installed on valve (please refer to manual override drawings)!
3. Auto sleep mode switches back to learning mode by pressing RESET button or by cycling power supply.

Wiring ③



Do not touch anything on the PCB! Switch off the power line before wire the actuator! Lethal voltage!
Wire the actuator according to the wiring diagram.

DIP switch settings ④

Factory settings:
ALL switches (except SW 1 which is in ON position) are in OFF position! ④



NOTE:
All combinations of DIP switches are allowed. All functions that are selected are added consecutively.

SW 1: 0/2 - Input signal range selector

If set to OFF position, the input signal is in the range from 2-10 V (voltage input) or from 4-20 mA (current input).

If set to ON position, the input signal is in the range from 0-10 V (voltage input) or from 0-20 mA (current input).

SW 2: D/I - Direct or inverse acting selector

If set to OFF position, the actuator is direct acting (stem lowers as voltage increases).

If the actuator is set to ON position, the actuator is inverse acting (stem raises as voltage increases).

SW 3: ---/Seq - Normal or sequential mode selector

If set to OFF position, the actuator is working in range 0(2)-10 V or 0(4)-20 mA.

If set to ON position, the actuator is working in sequential range; 0(2)-5(6) V or (0(4)-10(12) mA) or (5(6)-10 V) or (10(12)-20 mA).

SW 4: 0-5 V/5-10 V - Input signal range in sequential mode

If set to OFF position, the actuator is working in sequential range 0(2)-5(6) V or 0(4)-10(12) mA.

If set to ON position, the actuator is working in sequential range; 5(6)-10 V or 10(12)-20 mA.

SW 5: LIN/MOD - Linear or modified flow through the VZL valves

If set to ON position, the flow through the LINEAR characterized VZL valve will modify to equal percentage-wise equals the control signal.

If set to OFF position, the flow through the valve VZ or VZL remains same as is valve characteristic in accordance to the control signal.

SW 6: ---/ASTK - Anti-blocking function

Exercises the valve to avoid blocking in periods when the heating/cooling is off.

If set to ON position (ASTK), the valve motion is switched on. The actuator opens and closes the valve every 7 days.

If set to OFF position (---), the function is disabled.

SW 7: U/I - Input signal type selector

If set to OFF position, voltage input is selected.

If set to ON position, current input is selected

Reset button ④③

Press the reset button will cause the actuator to go through a self stroking cycle (press it for 2 s).

Manual override ⑤



Do not manually operate the drive if power is connected!
Do not dismount the actuator from the valve when it is in a stem down position!

If dismounted in a stem down position, there is a high risk that the actuator gets stuck.

- Remove cover ①
- Press and hold the button (on the bottom side of the actuator) ② during manual override ③
- Replace cover ④
- Install actuator on valve ⑤, ⑥



Remark:
A 'click' sound after energising the actuator indicates that the gear wheel has jumped into normal position.

LED signalisation ⑥

- - lit
- - no
- ⚙ - flashing

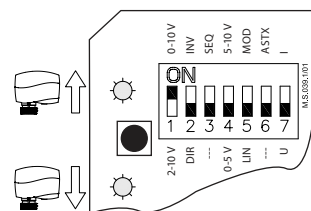

Dimensions ⑦

Part Name 部件名称	Hazardous Substances Table/有害物质含量表					
	Lead (Pb) 铅 (Pb)	Mercury (Hg) 汞 (Hg)	Cadmium (Cd) 镉 (Cd)	Hexavalent Chromium (Cr(VI)) 六价铬 (Cr(VI))	Polybrominated biphenyls (PBB) 多溴联苯 (PBB)	Polybrominated diphenyl ethers (PBDE) 多溴二苯醚 (PBDE)
Connecting nut/ 连接螺母	X	O	O	O	O	O
<p>O: Indicates that this hazardous substance contained in all of the homogeneous material for this part is below the limit requirement in GB/T 26572; O: 表示该有害物质在该部件所有均质材料中的含量均在GB/T 26572规定的限量要求以下。</p> <p>X: Indicates that this hazardous substance contained in at least one of the homogeneous material for this part is above the limit requirement in GB/T 26572; X: 表示该有害物质至少在该部件的某一均质材料中的含量超出GB/T 26572规定的限量要求。</p>						

