



Controller for temperature control - EKC 201C with double thermostat

Introduction

Application

- Controller used for temperature control of refrigeration appliances in supermarkets
- On account of the plug connections the controller's mounting is primarily intended for OEM's in the refrigeration appliance industry.

Principle

The controller contains a temperature control with a double thermostat function. The thermostat sensors are placed in the cold air current after the evaporator and in the hot air current right in front of the evaporator, respectively. Not until both thermostats call for refrigeration will the relay operate. When a "night lid" is placed on the appliance the controller will adapt itself to the changed circumstances. Another option is that only the S_{out} thermostat is selected to be active while the S_{in} temperature is selected for the display or that the S_{in} sensor is left out altogether.

Connection

The controller is provided with plug connections so that a quick connection can be made without use of screw terminals. Sensors with plug connections can be supplied in given lengths.

Advantages

- The controller can itself register whether the night lid is on or not.
- The controller has integrated refrigeration-technical functions so that it can replace a collection of thermostats and timers.
- Temperatures, times, operating conditions, parameter codes and alarm and error codes can be read on the display.
- Three LED's show the system's actual function:
 - refrigeration
 - defrost
 - fan operating
- When there is an alarm, all three LED's will flash.
- Easy to install data communication at a later date.

Functions

- Double thermostat function. (The S_{in} thermostat can be opted out).
- Changed alarm limits when night lid is on.
- Relay outputs for
 - refrigeration (compressor)
 - fan
 - defrost
 - alarm
- Digital inputs for, e.g.:
 - Coordinated defrost
 - start of defrost
 - retransmission of contact position via the data communication

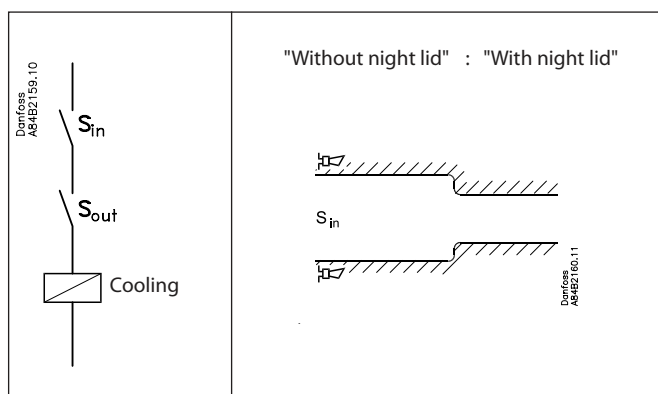
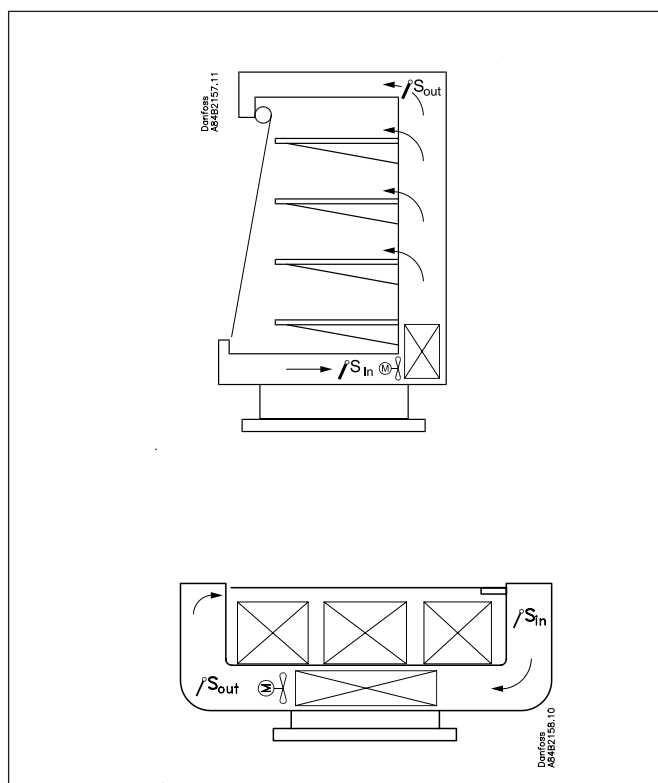
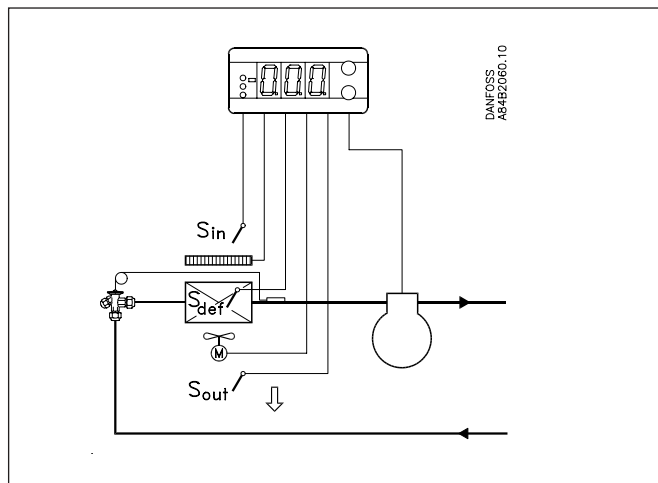

Function

The thermostat

The two temperatures S_{in} and S_{out} have their own thermostat function with belonging differential. Not until both thermostats call for cold temperatures will refrigeration be started.

The setting of the two thermostats is based on the following principle:

- The S_{in} thermostat is set so low that it will always call for refrigeration when the night lid is off
- S_{out} is set, so that it will be the controlling thermostat
- When the night lid is put on, the S_{in} temperature will fall and form part of the regulation
- If the refrigerating system works with a higher suction pressure during the night, the S_{out} thermostat will all the time call for cold, and accordingly the S_{in} thermostat will be the controlling thermostat.

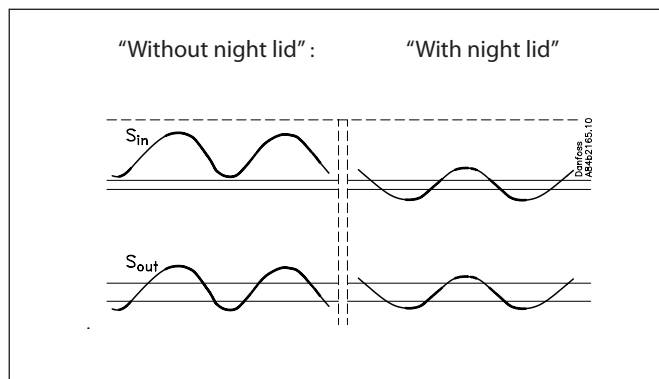

Coordinated defrost

Coordinated defrost can be carried out in two ways. Either with cable connections between the controllers or via data communication.

Wire connections

One of the controllers is defined as main controller, and a clock module may be mounted in it, if required. The other controllers are defined as secondary controllers.

The main controller can now start a defrost of all controllers simultaneously. The individual controllers will carry out the defrost and then go in waiting position until all controllers have concluded the defrost. The main controller will subsequently release all controllers to normal regulation.

Defrost via data communication

All controllers are fitted with a data communication module and via the override function from a gateway the defrost can be coordinated.

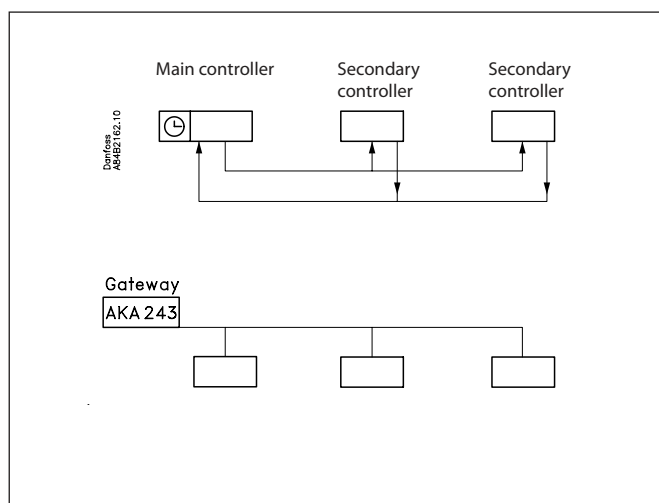

Extra options

- If it is required that the temperature has to be shown on the refrigeration appliance, a display can be mounted. This display will show the same values that are shown on the controller's display, but it contains no buttons for operation.
- The controller can be mounted at a later date with one plug module, if required by the application. The controller is prepared with a plug so that the module just has to be pushed in.
 - If it is required that the periodic defrost may be changed so that defrost can be performed at specific times of the day, a clock module may be mounted. It will then be possible to set up to six defrost times per day and night. The module is provided with battery backup.
 - If it is required that operation is to take place from a PC, a data communication module must be placed in the controller. Read more about data communication on page 14.

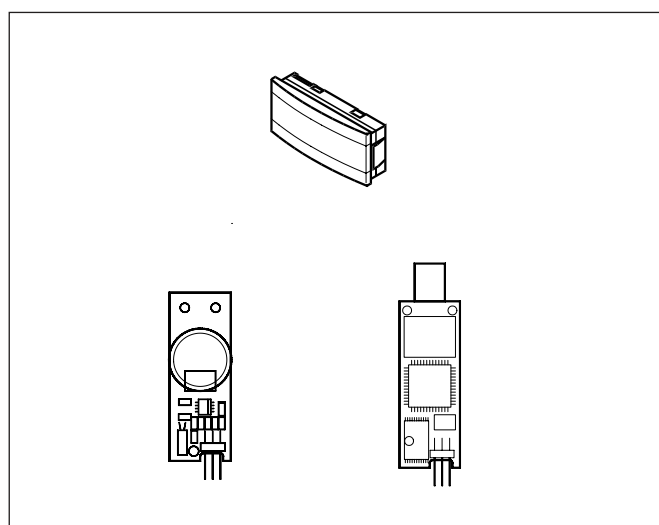

Survey of functions

Function	Parameter	Parameter by operation via data communication
Normal display		
Normally the temperature value is displayed from one of the two thermostat sensors S_{in} or S_{out} . In o17 is determined which one.		Sin Temp Sout Temp
Thermostat		Thermostat
Reference Regulation is based on the set value. See also pages 3 and 15.	Out	Sout Setpoint (Shown in all menu displays)
Temperature unit Here you select whether the controller is to indicate the temperature values in °C or in °F.	r05	T. Unit °C=0 °F=1 (In AKM only °C is displayed, whatever the setting).
Differential S_{out} When the S_{out} temperature is higher than the S_{out} reference plus the set differential, the thermostat function will call for refrigeration. The controller will not operate the compressor relay until both thermostats call for refrigeration.	r07	Sout Diff.
Differential S_{in} When the S_{in} temperature is higher than the S_{in} reference plus the set differential, the thermostat function will call for refrigeration. The controller will not operate the compressor relay until both thermostats call for refrigeration. (The setting/function can be opted out in O14).	r08	Sin Diff
Correction of signal from S_{out} (Compensation possibility through long sensor cable)	r09	Sout Offset
Correction of signal from S_{in} (Compensation possibility through long sensor cable)	r10	Sin Offset
S_{in} thermostat reference Here you set the number of degrees the S_{in} reference has to higher than the S_{out} reference. (See also page 15). (The set value represents the characteristic cold loss of the appliance).	r20	Delta Sin Sout
Alarm		Alarm settings
The controller can give alarm in different situations. When there is an alarm all the light-emitting diodes (LED) will flash on the controller front panel, and the alarm relay will be activated.		
Alarm delay If one of the two limit values is exceeded, a timer function will commence. The alarm will not become active until the set time delay has been passed. The time delay is set in minutes.	A03	Temp Alarm Del
Alarm delay for door alarm The time delay is set in minutes.	A04	Door Alarm Del
Upper deviation for S_{out} Here you set when the alarm for high temperature is to commence. The value is set in Kelvin The alarm will start if the temperature exceeds the set reference plus the upper deviation.	A05	Sout Upper Dev.
Lower deviation for S_{out} Here you set when the alarm for low temperature is to commence. The value is set in K. The alarm will start if the temperature goes further down than the set reference minus the lower deviation.	A06	Sout Lower Dev.
Upper deviation for S_{in} Here you set when the alarm for high temperature is to commence. The value is set in Kelvin. The alarm will start if the temperature exceeds the set reference plus the upper deviation.	A07	Sin Upper Dev.
Lower deviation for S_{in} Here you set when the alarm for low temperature is to commence. The value is set in Kelvin. The alarm will start if the temperature goes further down than the set reference minus the lower deviation.	A08	Sin Lower Dev.

Displacement of S_{in} alarms when the night lid is on This setting will displace the two alarm limits for S_{in} when the night lid has been put on. The value will be added to A07 and A08. (If a positive value is set, the limits will be extended. A negative value will narrow the limits).	A09	Sin Night Offset
		With data communication the importance of the individual alarms can be defined. Setting is carried out in the "Alarm destinations" menu. See also page 14.
		Alarm stat / relay Here you can read the alarm relay's status or you may force-control the relay in "Manual control" mode. ON = operating situation with alarm.
Compressor		Compressor
The compressor relay works in conjunction with the two thermostats. Only when both thermostats call for refrigeration will the compressor relay be operated.		
Running times To prevent irregular operation, values can be set for the time the compressor is to run once it has been started. And for how long it at least has to be stopped. The running times are not respected when defrosts are started.		
Min. ON-time (in minutes)	c01	Min. ON Time
Min. OFF-time (in minutes)	c02	Min. OFF Time
Safety functions for sensor defects If the room sensor becomes defective (is short-circuited or interrupted), the controller will start a control frequency of the compressor at the same time as an alarm will be given for the sensor defect. If the controller has been working for so long that the compressor relay has been operated 72 times, the controller will remember the different ON/OFF times of the compressor relay. The regulation will then continue with the established average ON/OFF period. If the controller has however not accomplished 72 operations, the regulation will use a time period of 20 minutes. During these 20 minutes the compressor will be started and stopped by this percentage setting. A setting of, say, 40% will operate the relay in eight of the 20 minutes.	c03	Cutin Freq
Compressor stop at open door If the digital input is used for a door monitoring function (see definition in the "Miscellaneous" section) the compressor can be stopped when the door is opened. With the setting Yes (ON) the compressor will be stopped.	c04	Cutout At Door
The LED on the controller's front panel will show whether refrigeration is in progress.		Comp Relay Here you can read the alarm relay's status or you may force-control the relay in "Manual control" mode.
Defrost		Defrost
The controller contains a timer function so that defrost is started periodically, e.g. every eight hours. If defrost is to be carried out at certain times of the day, the setting must be made accordingly, but the controller can also be fitted with a module containing a real-time clock. When this clock is mounted, defrost can be started at certain times of the day. You must set whether defrost is to be made with electricity or hotgas. The actual defrost is stopped on temperature.		
Compressor ON during defrost Here you have to set whether defrost is to be carried out with electricity or hotgas. During defrost the defrost relay will be operated. The setting will have an influence on the compressor relay's function during defrost. If "no" is selected, the compressor relay will not be activated. If "yes" is selected, the relay will be operated.	d01	Cut In at Def
Defrost stop temperature Defrost is stopped at a given temperature at the S_{def} sensor (or S_{out} cf. d10). The temperature value is set.	d02	Def Stop Temp

<p>Interval between defrost starts There are two setting options here. You either set the function in pos. OFF, or you set an interval. Set in pos. OFF if you arrange the defrost start by using input DI or if you mount a real-time module in the controller. Interval: Here you simply set how often defrost is to be started. If master/slave defrost without clock function is used, it will be the interval that determines the defrosts. If a defrost start via the data communication does not materialise, the interval will be used as max. time between defrosts.</p>	d03	Def Interval (0=off)
<p>Max. defrost duration This setting is a safety period, so that defrost will be stopped if there has not already been a stop based on temperature.</p>	d04	Max Def Time
<p>Time displacement of defrost cutins during start-up The function is only relevant, if you have several refrigeration appliances or groups where you would like the defrost to be displaced. This function is also only relevant if you have selected defrost with interval start (d03). The function delays the defrost by the set number of minutes, but for the very first defrost it only does it when the controller has been energised.</p>	d05	Time Stagger
<p>Drip-off time Here you set the time that is to elapse from the end of a defrost and until compressor is to be resumed. (The time when water is dripping off the evaporator).</p>	d06	Drip Off Time
<p>Fan start delay after defrost Here you set the time that is to elapse from the compressor is started after a defrost and until the fan may resume operation. (The time where the water is "bound" to the evaporator).</p>	d07	Fan Start Del
<p>Fan start temperature The fan may also be started a little earlier than mentioned under "Delayed fan start after defrost" if the defrost sensor registers a permissible value. Here you can set the value for when the fan may start.</p>	d08	Fan Start Temp
<p>Fan cut in during defrost Here you set whether the fan is to operate during defrost.</p>	d09	Fan During Def
<p>Defrost sensor Here you set whether the defrost sensor is to be S_{def} or S_{out}</p>	d10	Def Sen Out=0 1 = S_{def}
<p>Delayed temperature alarm after defrost During and immediately after a defrost the temperature is "too high". The "high temperature alarm" can be suppressed right after a defrost. Here you must set for how long the alarm is to be suppressed.</p>	d11	Def Alarm Del
<p>Delay of display view after defrost During and immediately after a defrost the temperature is "too high". The display of this "too high" temperature is cancelled during the defrost and may furthermore be suppressed right after a defrost. Here you set for how long the exact measurement may be suppressed. During and immediately after a defrost the display will show "-d-".</p>	d12	Delay Display
<p>Defrost at power up Here you set whether the controller is to start with a defrost, if there has been a power failure.</p>	d13	Def At Power Up
<p>If you wish to see the temperature at the S_{def} sensor, push the controller's lower button.</p>		Defrost temp.
<p>If you wish to start an extra defrost, push the controller's lower button for 20 seconds. You can stop an on-going defrost in the same way.</p>		Def Start Here you can start a manual defrost
<p>The LED on the controller's front panel will show whether a defrost is in progress.</p>		Defrost Relay Here you can read the defrost relay status, or you can force-control the relay in "Manual control" mode.

Realtime clock		
The controller has room for one plug module which may either be a data communication module or a real-time module. When a data communication module is mounted, the controller can be connected to a Danfoss gateway type AKA 243. Operation of the controller can now take place via the data communication. Please cf. separate literature.		
Real time clock With this module up to six individual times can be set for defrost starts per day and night. Defrost start, time setting	t01-t06	
Defrost start, minute setting (1 and 11 belongs together etc.)	t11-t16	
Setting of hours	t07	
Setting of minutes	t08	
Fan		Fan
In addition to the fan functions during defrost the fans may also be stopped as a function of the compressor operation.		
Fan stop on compressor cut out Here you can select whether the fan must be stopped when the compressor is cut out.	F01	Fan Stp Comp (ON = stopped fan)
Delayed fan stop when compressor is cut out If you have chosen to stop the fan when the compressor is cut out you can delay the fan stop after the compressor has stopped. Here you set the time delay.	F02	Fan Del At Comp
Fan stop at open door If you have selected the DI input for monitoring of a door switch you can also have the fan stopped when the door is registered open. Select Yes or No to the function.	F03	FanStpAtDoor
The LED on the controller's front panel will show whether the fan is operating.		Fan Relay Here you can read the fan relay's status or you may force-control the relay in "Manual control" mode.
Miscellaneous		Miscellaneous
Delay of output signal after start-up After start-up or a power failure the controller's functions can be delayed so that overloading of the electricity supply network is avoided. Here you can set the time delay	o01	Delay Of Out
Digital input control The controller has a digital input "DI" which can be used for one of the following functions: Off: Input not used. 1) Data communication. If a module with data communication is mounted, this setting 1 should be selected, but settings/ functions 3 and 4 are also allowed. 2) Defrost. A contact function with return spring is fitted. The controller will register when the DI input is activated. The controller will then start a defrost cycle. If the signal is to be received by several controllers it is important that ALL connections are mounted the same way (DI to DI and GND to GND). It is also a requirement that all controllers are supplied with power from their own separate power supply units. 3) Night lid. When the input is short-circuited this is a signal that the night lid has been put on. 4) Main switch. Regulation is carried out when the input is short-circuited, and regulation is stopped when the input is put in pos. OFF. 5) Coordinated defrost with wire connections. (However, if coordinated defrost via data communication is used, setting 5 must not be used). 6) Door. When the input is shortcircuited it signals that the door is open.	o02	DI Config Definition takes place with the numerical value shown to the left. (0 = off) DI State (Measurement) The DI input's present status is shown here. ON or OFF.
Address If the controller is built into a network with data communication, it must have an address, and the master gateway of the data communication must then know this address. These settings can only be madewhen a data communication modulehas been mounted in the controller and the installation of the data communication cable has been completed. This installation is mentioned in a separate document "RC.8A.C".. The address is set between 1 and 60 The address is sent to the gateway when the menu is set in pos. ON		Following installation of a data communication module, the controller can be operated on a par with the other controllers in ADAP-KOOL® refrigeration controls.
	o03	
	o04	

<p>Access code If the settings in the controller are to be protected with an access code you can set a numerical value between 0 and 100. If not, you can cancel the function with setting OFF.</p>	o05	-
<p>Used sensor type Normally a Pt 1000 sensor with great signal accuracy is used. But you may also use a PTC sensor (R25 = 1000) in special situations. When a PT 1000 sensor is used, the temperature is shown with one decimal. If you use a PTC sensor the temperature will be displayed in whole figures.</p>	o06	Sens Typ Pt=0 PTC = 1
<p>Coordinated defrost with wire connections Connections to the controller must be made as described on page 13. Off: No coordinated defrost with wire connections 1: Main controller (only one controller in the group can be master) 2: Secondary controller If there is coordinated defrost via data communication, the setting must be OFF. If the function is set in the secondary controller prior to being set in the main controller, this will start a defrost. This can be avoided by setting the main controller before the secondary controller.</p>	o13	DO Config Off = 0 Main controller = 1 Secondary controller = 2
<p>Active thermostat (Active sensor) Normally regulation is carried out with both thermostats, but the S_{in} thermostat may be left out, if desired. Aut: Both thermostats participate in the regulation. Out: Only the S_{out} thermostat is used. If S_{in} is also opted out in o17 the sensor may be left out altogether.</p>	o14	Act. Sen. AUT=0 Sout = 1
<p>Display step Normally the temperature is shown with 1° steps if PTC sensors are used, and with 0.1° steps if PT sensors are used. These 0.1° steps may be raised to 0.5°, if required. Yes: Gives steps of 0.5° No: Gives steps of 0.1° The 1° step for PTC sensors cannot be changed.</p>	o15	Disp Step = 0.5
<p>Max. standby time after coordinated defrost When a controller has completed a defrost it will wait for a signal which tells that the refrigeration may be resumed. If this signal fails to appear for one reason or another, the controller will itself start the refrigeration when this standby time has elapsed.</p>	o16	Max Hold Time
<p>Select sensor signal for the display Automatic changeover between S_{out} and S_{in}. S_{out} is shown when the night lid is off, and S_{in} when the night lid is on. Sout: Always S_{out} Sin: Always S_{in}</p>	o17	Dis Sen AUT=0 Sout = 1 Sin = 2
<p>Manual control of outputs In connection with service the individual relay outputs and the digital output can be changed to pos. ON. Off: No override 1: Compressor relay is ON 2: Defrost relay is ON 3: Fan relay is ON 4: Alarm relay is ON 5: Signal to slave controllers that defrost is required</p>	o18	Manual Contr (Shown in all menu displays) Set in pos. ON whereafter the relevant relay can be controlled by force. Remember to reset the function to OFF.
<p>Alarm/light Here you define whether the relay on terminals 20-21 is to be used for an alarm relay or for a light function. 1=alarm. The relay cuts out when there is an alarm. 2=light. The relay cuts in during periods with light. (daytime).</p>	o36	AuxRelConfig
		DO State Here you can read the output's status or you can force-control the output in "Manual control" mode.
		Hold After Def Shows ON if the controller is operating with coordinated defrost.
		- - - Night Setback 0=Day 1=Night (as 414C)

Fault message		Alarms
<p>In an error situation the LED's on the front panel will flash and the relay will be activated. If you push the top button in this situation you can see the alarm report in the display.</p> <p>There are two kinds of error reports - it can either be an alarm occurring during the daily operation, or there may be a defect in the installation.</p> <p>A-alarms will not become visible until the set time delay has expired.</p> <p>E-alarms, on the other hand, will become visible the moment the error occurs.</p> <p>Here are the messages that may appear:</p>		
A4: Door alarm		Door Alarm
A5: Information. Parameter o16 has expired		Max Hold Time
A6: High-temperature alarm S_{out}		Sout High Temp.
A7: Low-temperature alarm S_{out}		Sout Low Temp.
A8: High-temperature alarm S_{in}		Sin High Temp.
A9: Low-temperature alarm S_{in}		Sin Low Temp.
E1: Fault in controller		Contr Fault
E4: S_{def} disconnected		Def Sensor Err.
E5: Short-circuited S_{def}		Def Sensor Err.
E6: Error in real-time clock. Check battery/ Reset clock.		-
E7: S_{out} disconnected		Sout Sensor Err.
E8: Short-circuited S_{out}		Sout Sensor Err.
E9: S_{in} disconnected		Sin Sensor Err.
E10: Short-circuited S_{in}		Sin Sensor Err.

Menu survey

SW = 1.2x

Function	Parameter	Min.	Max.
Normal display			
Shows the temperature at the selected sensor	-		°C
Give the lower button a brief push to see the temperature at the defrost sensor	-		°C
Give both buttons a brief push simultaneously to see the temperature at the other thermostat sensor	-		°C
Thermostat			
Cutout value for S_{out}	Out	-50°C	50°C
Temperature unit	r05	°C	°F
Differential S_{out}	r07	0.1 K	20 K
Differential S_{in}	r08	0.1 K	20 K
Correction of the signal from S_{out}	r09	-20.0 K	20.0 K
Correction of the signal from S_{in}	r10	-20.0 K	20.0 K
Delta $S_{in} S_{out}$ (S_{in} reference)	r20	0	10 K
Alarm			
Delay for temperature alarm	A03	0	90 min
Door alarm delay.	A04	0	60 min
Upper deviation for S_{out} (above the temp. setting)	A05	0 K	50 K
Lower deviation for S_{out} (below the temp. setting)	A06	-50 K	0 K
Upper deviation for S_{in} (above the temp. setting)	A07	0 K	50K
Lower deviation for S_{in} (below the temp. setting)	A08	-50 K	0 K
Displacement of S_{in} alarms when night lid is on	A09	-50 K	50 K
Compressor			
Min. ON-time	c01	0 min	15 min
Min. OFF-time	c02	0 min	15 min
Cutin frequency on sensor fault	c03	0 %	100 %
Compressor stop at door alarm (Yes/No)	c04	No	Yes
Defrost			
Compressor ON during defrost	d01	No	Yes
Defrost stop temperature	d02	0	25°C
Interval between defrost starts	d03	OFF	48 hours
Max. defrost duration	d04	0	180 min
Time displacements for defrost cutins during start-up	d05	0	60 min
Drip-off time	d06	0	20 min
Delay for fan start or defrost	d07	0	20 min
Fan start temperature(>25°C =OFF)	d08	-25	26°C
Fan cut in during defrost (yes/no)	d09	no	yes
Defrost sensor Out: S_{out} used. Def: S_{def} used	d10	Out	Def
Delay for temperature alarm after defrost	d11	0	200 min
Delay of display view after defrost	d12	0	30 min.
Defrost at power up	d13	no	yes
Realtime clock (if mounted)			
1. Defrost start. Hours	t01	OFF	23hours
1. Defrost start. Minutes	t11	0	59 min
2. Defrost start. Hours	t02	OFF	23hours
2. Defrost start. Minutes	t12	0	59 min
3. Defrost start. Hours	t03	OFF	23hours
3. Defrost start. Minutes	t13	0	59 min
4. Defrost start. Hours	t04	OFF	23hours
4. Defrost start. Minutes	t14	0	59 min
5. Defrost start. Hours	t05	OFF	23hours
5. Defrost start. Minutes	t15	0	59 min
6. Defrost start. Hours	t06	OFF	23hours
6. Defrost start. Minutes	t16	0	59 min
Setting of Hours	t07	0	23hours
Setting of Minutes	t08	0	59 min
Fan			
Fan stop on compressor cut out	F01	no	yes
Delay for fan stop when compressor cuts out	F02	0	15 min
Fan stop at open door (yes/no)	F03	No	Yes

Miscellaneous			
Delay of output signal after start-up	o01	0	600 sec
Digital input signal: OFF=not used, 1=Data communication, 2=Defrost, 3=Night cover, 4=External start/stop, 5=Coordinated defrost with wire connections 6=Door switch	o02	OFF	5
Network address (range = 0-60)	o03*	0	990
ON/OFF switch (service-pin message)	o04*	OFF	100
Access code	o05	OFF	100
Used sensor type (Pt / PTC)	o06	Pt	PTC
Coordinated defrost with wire connections OFF= not used, 1=Main controller, 2=Secondary controller	o13	OFF	2
Active thermostat (active sensor) Aut: Both thermostats Out: only S_{out}	o14	Aut	Out
Display step = 0.5 (only if Pt sensor) no=0.1 , yes=0.5	o15	no	yes
Max. Hold time after coordinated defrost	o16	1	30 min
Select sensor signal for the display Aut: Automatic S_{out}/S_{in} changeover Out: Always S_{out} , In: Always S_{in}	o17	Aut	In
Manual control of outputs OFF=No manual control 1: Compressor output selected ON 2: Defrost output selected ON 3: Fan output selected ON 4: Alarm output selected ON 5: DO output selected ON When manual control is finished, the setting must be changed to OFF.	o18	OFF	5
Relay used (Alarm/light)	o36	1	2

*) This setting will only be possible if a data communication module has been installed in the controller.

Factory setting

If you need to return to the factory-set values, it can be done in this way:

- Cut out the supply voltage to the controller
- Keep both buttons depressed at the same time as you reconnect the supply voltage

Data

Supply voltage	12 V a.c./d.c. +15/-15 %	
Power consumption	2,5 VA The controllers must be connected to separate transformer of min. 3 VA	
Sensors (3)	Pt 1000 or PTC (R25 = 1000 ohm)	
Controller sensor system	Measuring range	-60 to +50°C
	Accuracy	±0,5°C for sensor temperature -35 to +25°C; ±1°C for sensor temperature -60 to -35°C and +25 to +50°C
Display	LED, 3-digits	
Digital input	Signal from contact function	
Electric connecting cable	Max. 1.5 mm ² multi-wire cable	
Relays	Refr. relays	SPST NC, I _{max.} = 6 A ohmic/ 3 A AC 15* inductive
	Defrost relays	SPST NO, I _{max.} = 6 A ohmic/ 3 A AC 15* inductive
	Fan motor relays	SPST NC, I _{max.} = 6 A ohmic/ 3 A AC 15* inductive
	Common terminal	Max. 11 A in the common connection
	Alarm relays	SPST NO, I _{max.} = 4 A ohmic/ 1 A AC 15* inductive I _{min.} = 1 mA at 100 mV**
Ambient temperature	Dur. operation	0 - 55°C
	Dur. transport	-40 - 70°C
Density	IP 54	
Approvals	EU Low Voltage Directive and EMC demands re CE-marking complied with. LVD-tested acc. to EN 60730-1 and EN 60730-2-9, A1, A2 EMC-tested acc. to EN50082-1 and EN 60730-2-9, A	

* AC 15 load acc. to EN 60947-5-1

** Gold coating ensures cutin function at small contact loads

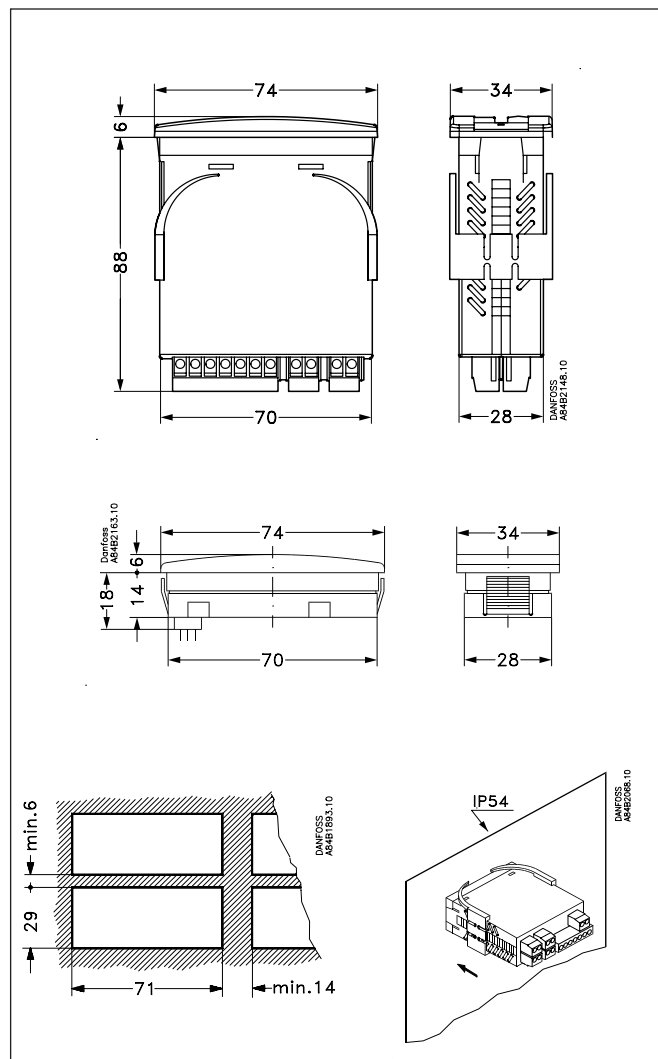

Product survey



Ordering

Type	Function	Code no.
EKC 201C	Temperature controller with coordinated defrost via wire connections	084B7068
EKA 172	Real time clock	084B7070
EKA 171C	Data communication module (FTT 10 module)	084B7255
	Data communication module (RS 485 module)	084B7256
EKA 161	Display unit	084B7019
-	Wire for the display unit (2 m with plug, 24 pcs.)	084B7179

Connections

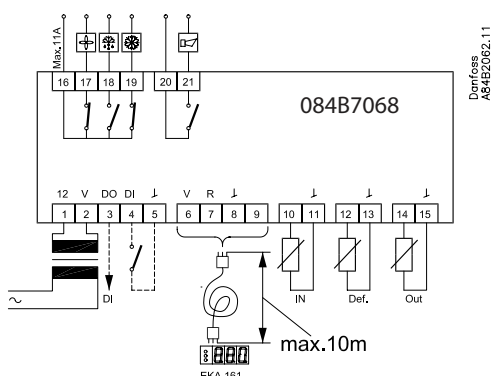

Posterior view of controller



The cable length between the external display types EKA 161 and EKC 201 must be max. 10 m

Relais terminals	Alarm relais	Room for data communication or clock
Supply voltage and digital inputs	External display, if applicable	Sensors S_{in} , S_{def} , S_{out}

Plug

The belonging plugs are not bypacked.

• The green plugs (light on photo) are of the type Phöenix.

The opposite plugs are with screw terminals and called:

- MVSTBW 2,5/4 - ST - 5,08

- MVSTBW 2,5/2 - ST - 5,08

- MCVW 1,5/5 - ST - 3,81

• The black plugs are of the type AMP module 2 (4-poled and 2-poled)

(Danfoss can supply sensors with plug)

Sensors

S_{out} sensor must be connected. S_{def} is optional.

S_{in} sensor must be connected, if $\phi 14 = \text{Aut}$ and $\phi 17$ differs from Out (=Aut/=In)

Alarm relais

There is no connection between the contacts in alarm situations and when the controller is de-energised. The contacts are closed during normal operation without alarm.

Data communication

If a data communication module has been mounted, it is important that the installation of the data communication cable be done correctly.

Cf. separate literature No. RC.8A.C...

Coordinated defrost via wire connections

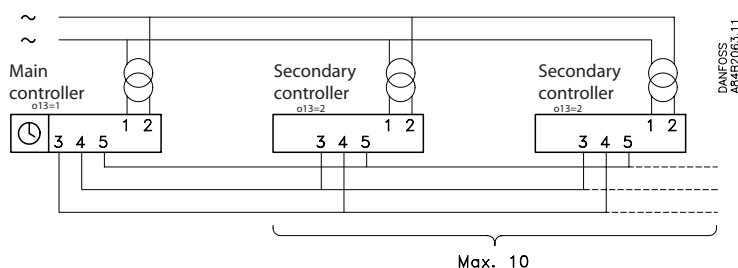

Coordinated defrost via data communication

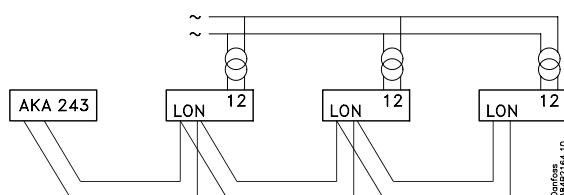

Data communication

This page contains a description of a few of the possibilities you will have when the controller is provided with data communication.

If you want to know more about operation of controllers via PC, you may order additional literature.

Examples

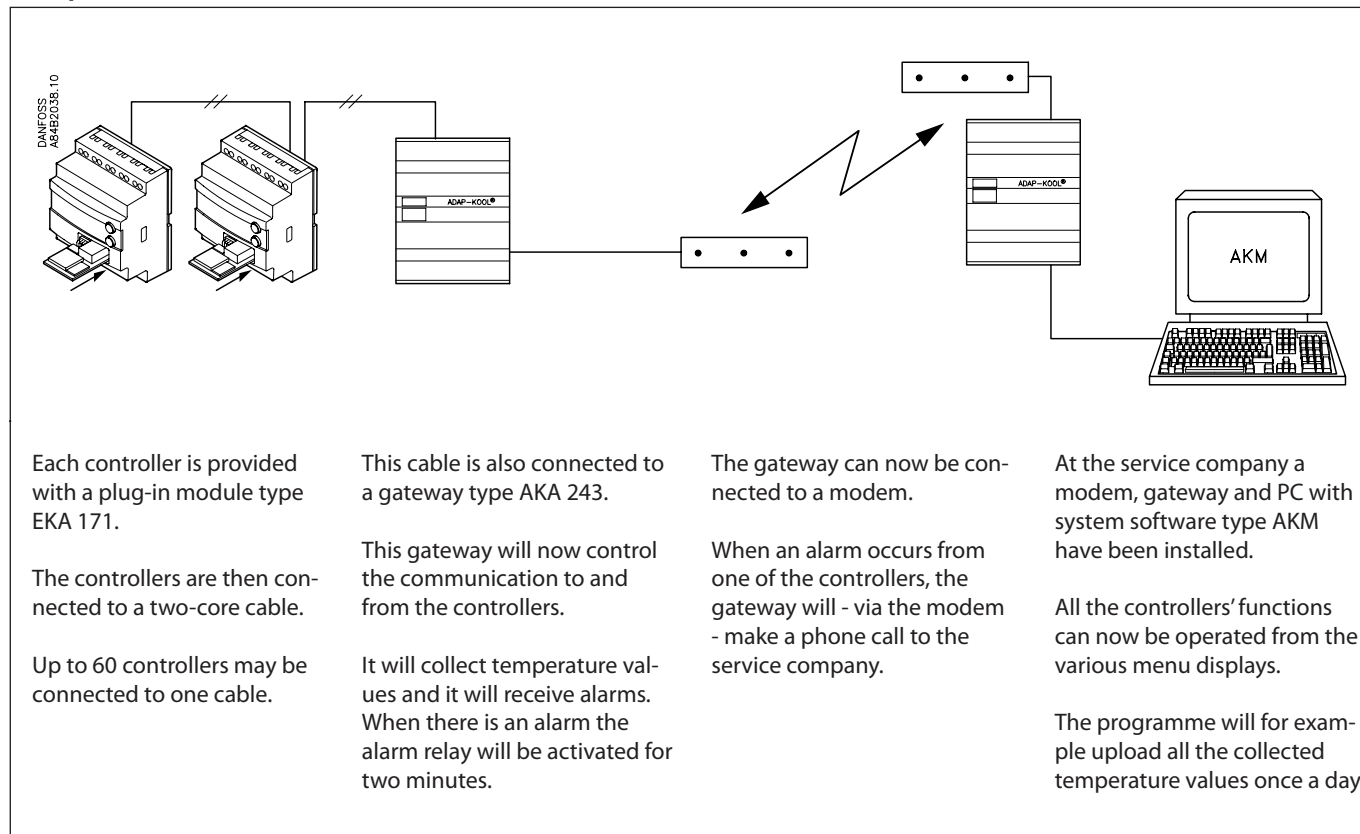

Each controller is provided with a plug-in module type EKA 171.

The controllers are then connected to a two-core cable.

Up to 60 controllers may be connected to one cable.

This cable is also connected to a gateway type AKA 243.

This gateway will now control the communication to and from the controllers.

It will collect temperature values and it will receive alarms. When there is an alarm the alarm relay will be activated for two minutes.

The gateway can now be connected to a modem.

When an alarm occurs from one of the controllers, the gateway will - via the modem - make a phone call to the service company.

At the service company a modem, gateway and PC with system software type AKM have been installed.

All the controllers' functions can now be operated from the various menu displays.

The programme will for example upload all the collected temperature values once a day.

Example of menu display

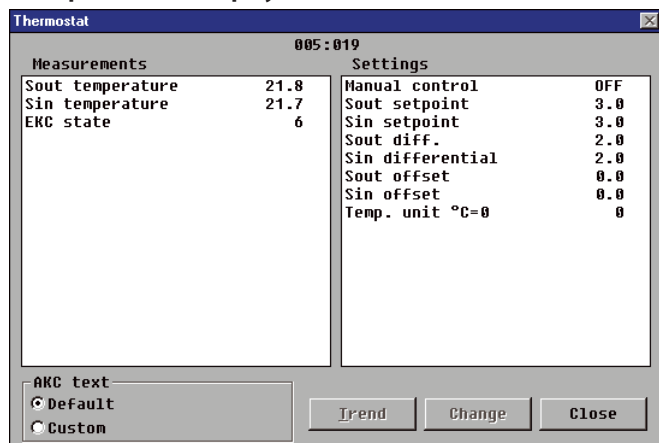

• Measurements are shown at one side and settings at the other.

• You will also be able to see the parameter names of the functions on page 4-9.

• With a simple change-over the values can also be shown in a trend diagram.

• If you wish to check earlier temperature measurements, you can see them in the log collection.

Alarms

If the controller is extended with data communication, it will be possible to define the importance of the transmitted alarms.

The importance is defined with the setting: 1, 2, 3 or 0. When the alarm then arises at some time, it will result in one of the following activities:

1 = Alarm

The alarm message is sent off with alarm status 1. This means that the gateway with address 125 in the system will have its alarm relay output activated for two minutes. Later, when the alarm ceases, the alarm text will be retransmitted, but now with status value 0.

2 = Message

The alarm text is transmitted with status value 2. Later, when the "message" lapses, the alarm text is retransmitted, but now with status value 0.

3 = Alarm

As "1", but the master gateway's relay output is not activated.

0 = Suppressed information

The alarm text is stopped at the controller. It is transmitted nowhere.

Appendix

Night lid on or off

The controller uses the function to indicate either the S_{out} temperature (night lid off) or the S_{in} temperature where it also uses other alarm limits (night lid on).

The situation is either determined by a contact function on the DI input or by the interaction between the two thermostat functions.

- If S_{in} constantly calls for refrigeration and S_{out} is the thermostat that cuts in and out, the night lid is off.
- If S_{in} participates in the thermostatic control together with S_{out} the night lid has been put on.

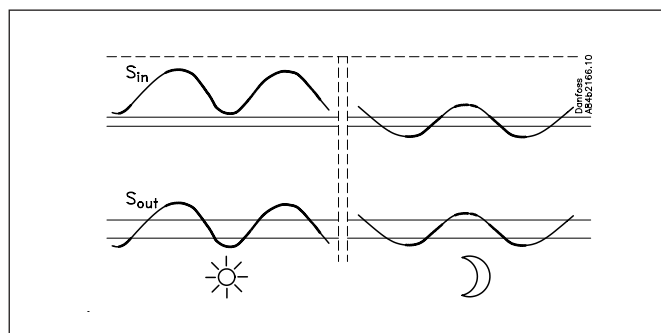

Temperature alarms

There are min. and max. limits for both the S_{in} temperature and S_{out} temperature. The values for S_{in} can be displaced when the regulation registers that the night lid has been put on, or if a signal is received at the DI-input and this input has been defined for setting 3.

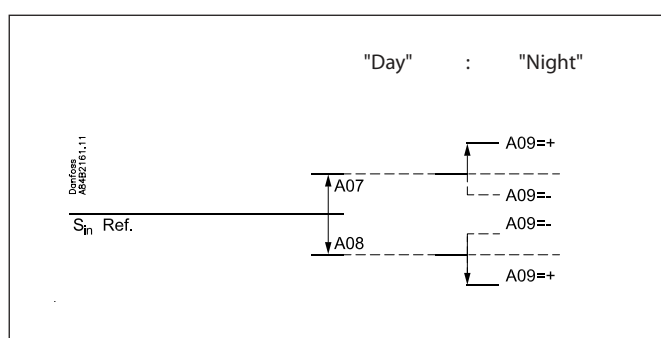

How to set the controller

1. Set the S_{out} thermostat to the expected temperature
2. Set r20, so that S_{in} thermostat will not cut out
3. Wait for the temperature to fall, and the S_{out} thermostat will cut out and in
4. Measure the S_{in} temperature (the product temperature will be a couple of degrees lower than the S_{in} temperature)
5. If the S_{in} temperature is satisfactory, proceed to the next point. If not, change the setting of the S_{out} thermostat and repeat the above procedure
6. When the setting of the S_{out} thermostat has been completed the S_{in} thermostat can be set.

Note the S_{in} temperature: it will fluctuate a couple of degrees depending on when the S_{out} thermostat cuts in and out. Register the lowest S_{in} temperature.

Set the S_{in} reference (r20) so that the reference plus the S_{in} differential will be one degree lower than the lowest S_{in} temperature. (The S_{in} differential is normally smaller than the S_{out} differential).

The S_{in} reference must be set higher than the highest S_{out} temperature.

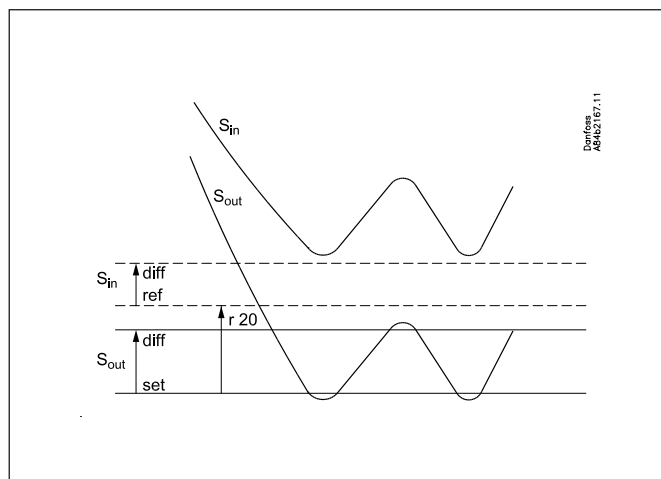

If you cannot start the controller

Check:

- that the sensors used are of the same type as the ones set in O06
- the S_{in} thermostat's setting
- the operating status of the controller

