

Luft-Wasser-Wärmepumpe

LIA 1316HXCF

1

electrical layout

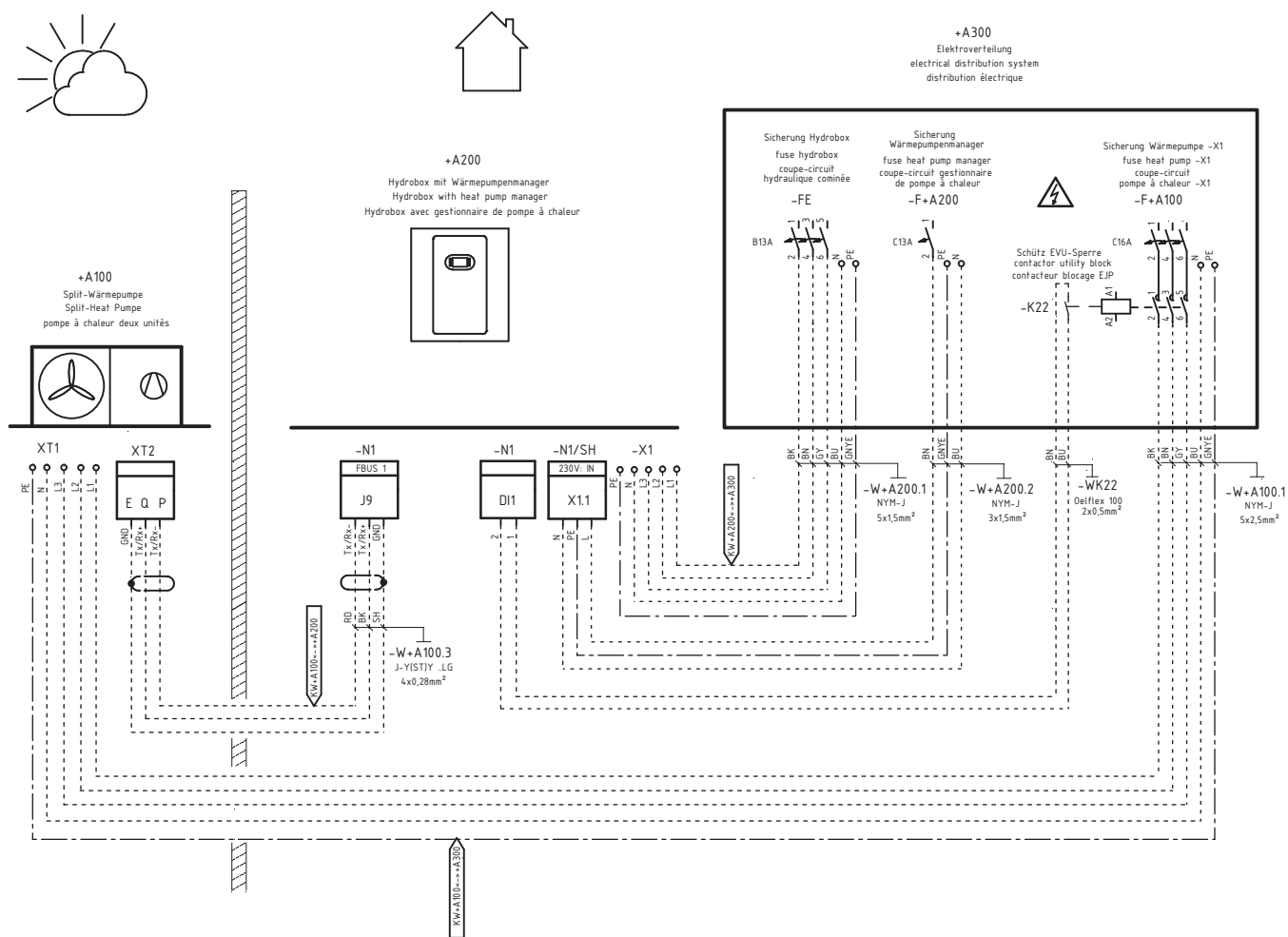



2

hydraulic

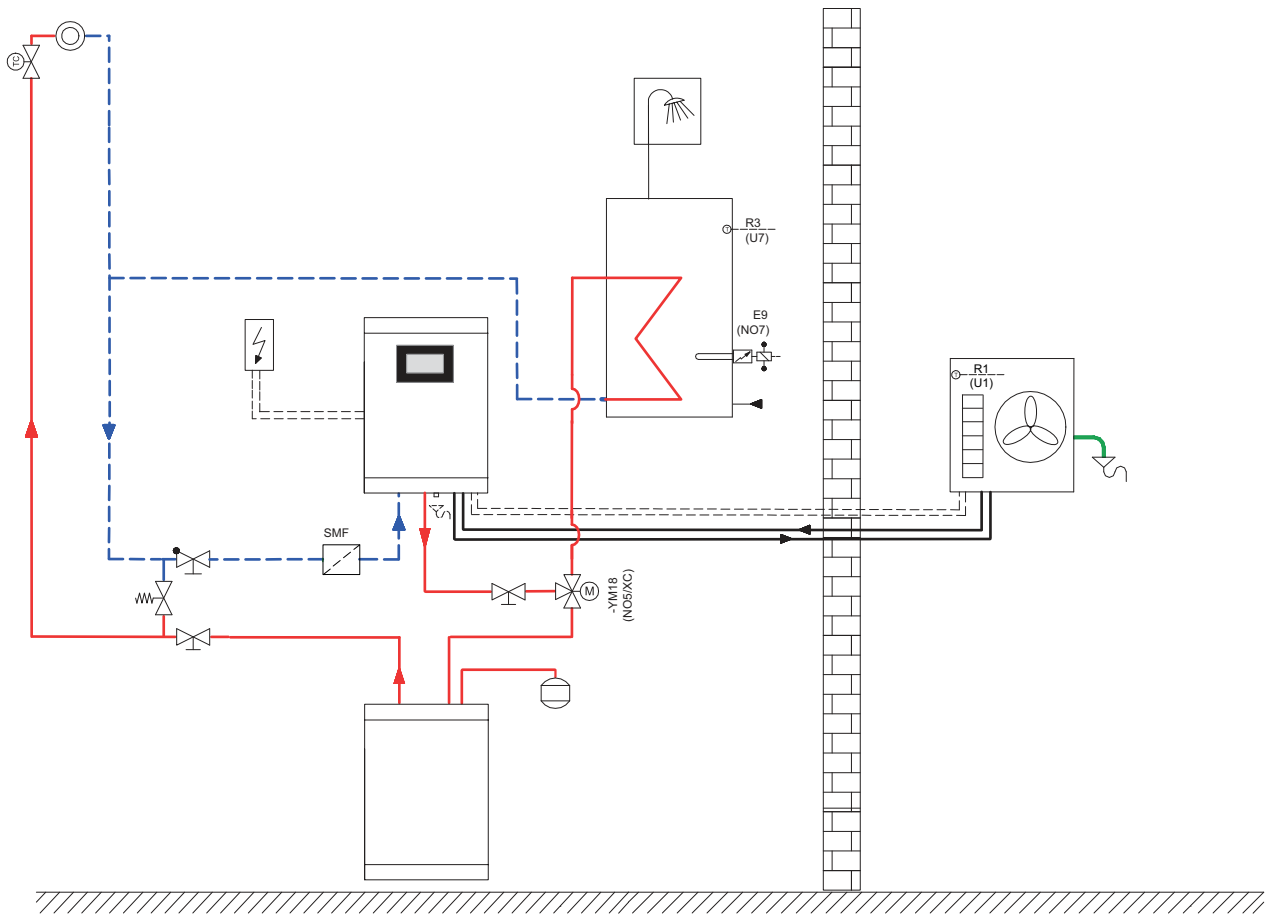

hydraulic 1

3

plug in

