

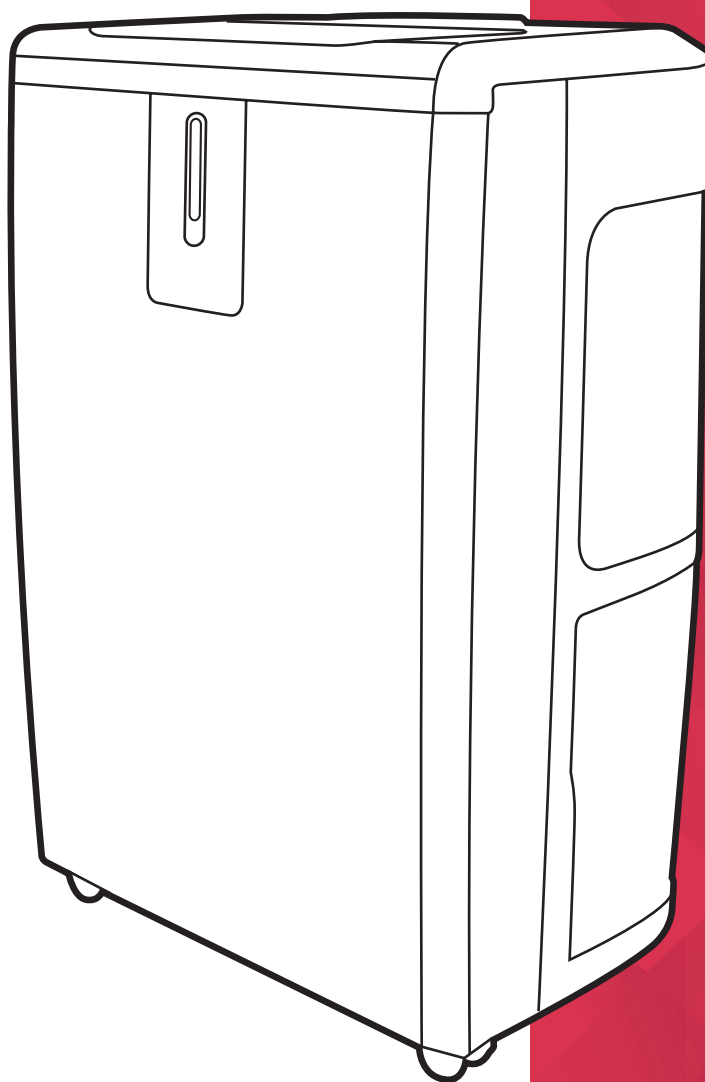

INSTRUCTION MANUAL



Dimplex
everdri

Models: 10/14 E and EL

For domestic household use only.



These products fully comply with all current European Safety Standard requirements for Dehumidifiers and are fully compliant with the Low Voltage Directive 2014/35/EU, the EMC Directive 2014/30/EU and the RoHS Directive 2015/863/EU.

08/80070/0 ISSUE: 5 Series: A



NB These symbols on your device mean:

- This appliance is filled with Propane gas R290. Follow strictly the manufacturer's instruction concerning use and repairs!
- Before using this appliance, you must carefully read the entire instruction manual.
- Do not install, operate or store the device in a room with a floor area smaller than 4m² for 10L models, and 7m² for 14L models.
- Repairs must be performed based on the recommendations from the manufacturing company.

SPECIFIC SAFETY NOTES RELATING TO REFRIGERANT R290:

- ENVIRONMENTAL INFORMATION: This unit contains fluorinated greenhouse gas covered by the Kyoto Protocol.
- This appliance contains the refrigerant R290.
- R290 is a refrigerant that complies with European ecological standards; nevertheless, it is recommended not to pierce the cooling circuit of the machine. At the end of its useful life, deliver the appliance to a special waste collection centre for disposal.
- GWP (Global Warming Potential) R290 = 3.
- If the appliance is installed, operated or stored in a non-ventilated area, the room must be designed to prevent the accumulation of refrigerant leaks resulting in a risk of fire or explosion due to ignition of the refrigerant caused by electric heaters, stoves, or other sources of ignition.
- When defrosting and cleaning the appliance, do not use any tools other than those recommended by the manufacturing company.
- The appliance must be placed in an area without any continuous sources of ignition (for example: open flames, gas or electrical appliances in operation).
- Do not pierce or burn any of the components of the cooling circuit of the unit. Do not set light to the unit.
- The appliance must be stored in such a way as to prevent mechanical failure or damage.
- Appliance must be installed, operated and stored in a room with a floor area larger than 4m² for 10L models, approximate room size 2m x 2m, and 7m² for 14L models, approximate room size 2.6m x 2.6m.
- Be aware that the refrigerant gases may be odourless, which means you cannot smell leaks.
- Compliance with national gas regulations must be observed.
- Individuals who operate or work on the refrigerant circuit must have the appropriate certification issued by an accredited organisation that ensures competence in handling refrigerants according to a specific evaluation recognised by national associations in the industry.
- Maintenance and repairs that require the assistance of other qualified personnel must be performed under the supervision of an individual specifically qualified in the use of flammable refrigerants. Keep ventilation openings clear of obstruction.



IMPORTANT

THESE INSTRUCTIONS SHOULD BE READ CAREFULLY AND RETAINED FOR FUTURE REFERENCE. **Note also the information presented on the appliance**

CAUTION: FAILURE TO FOLLOW THESE INSTRUCTIONS MAY CAUSE INJURY AND/OR DAMAGE AND MAY INVALIDATE YOUR GUARANTEE

Please read the operating instructions carefully before using your dehumidifier for the first time and keep them in a safe place.

WARNING – This appliance must not be used in a bathroom.

WARNING – Do not use this appliance in the immediate surroundings of a bath, a shower or a swimming pool.

- Never immerse the appliance in water or other liquids.
- Operate this unit only on a firm, flat surface to avoid the risk of water leakage or damage. Ensure that the unit is kept upright at all times (including during transport and storage). If it is overturned at any stage it should be left standing upright for 24 hours before use.
- Do not place on soft, unstable or non-horizontal/angled surfaces.
- Leave the unit to stand for 12 hours before connecting to the mains supply after transport or when it has been tilted (e.g. During cleaning).
- When the unit stops, you have to wait for 3 minutes before you can restart the unit to protect the compressor from damage.
- Never operate the appliance if a cable or connector has been damaged, after appliance malfunction or if the appliance was dropped or is otherwise damaged.
- If the mains lead is damaged it must only be replaced by the manufacturers service agent or a similarly qualified person in order to avoid a hazard.
- Please ask a professional service agent to repair the product. Improper repair may cause danger to users.
- Always switch off the unit and take the plug out of the socket
 - If you are not using the unit,
 - Before you clean or carry out maintenance on the unit,
 - If a fault occurs,
 - In the event of an electrical storm.
- Operate the appliance only at the voltage specified on the rating label.
- Only connect the unit to a properly installed and easily accessible socket so that you can quickly disconnect the plug if necessary.
- Do not connect this product to the mains using an extension lead.
- Do not connect the dehumidifier to a multiple socket outlet, which is also being used for other electrical appliances.
- This dehumidifier is only intended for **INDOOR RESIDENTIAL** applications. This dehumidifier should not be used for commercial or industrial or leisure applications or in small enclosed spaces.
- Never use the mains lead as a carrying strap or to pull the product when moving.
- To avoid a fire or electrocution hazard, **NEVER** put the cord near heat registers, radiator, stoves or heaters.

- **DO NOT** cover cord with carpeting, throw rugs, runners, or similar coverings.
- **DO NOT** route cord under furniture or appliances. Take care to position the cord away from traffic areas and where it will not be a tripping hazard.
- **DO NOT COVER.** Never cover or obstruct in any way the outlet at the top of the dehumidifier or the air inlet slots at the rear of the dehumidifier.
- Only operate this appliance with a minimum of 50cm clearance all around i.e. away from walls, furniture and overhanging objects such as curtains or a shelf.
- **IMPORTANT:** Do not use this unit where the ambient temperature is lower than 5°C, otherwise the evaporating coil will ice up heavily and this will affect the performance of the product and potentially cause a malfunction.
- Children aged from 3 years and less than 8 years shall only switch on/off the appliance provided that it has been placed or installed in its intended normal operating position and they have been given supervision or instruction concerning use of the appliance in a safe way and understand the hazards involved. Children aged from 3 years and less than 8 years shall not plug in, regulate and clean the appliance or perform user maintenance.
- Children of less than 3 years should be kept away unless continuously supervised.
- To prevent spillage, empty the water tank before lifting or relocating the appliance.
- Do not tip the appliance to any side as escaping water could damage the appliance.
- Do not use in cabinet, closet, boats, caravans or similar locations.
- Do not use the unit in a potentially explosive environment containing combustible liquids, gases or dusts. Do not use the appliance in the vicinity of flammable or explosive substances or fuels. Never use any paint, cleaning sprays, anti-insect sprays or similar near the unit; this could damage or deform the plastic, cause electrical damage or be a fire or explosion risk.
- Never leave this product running unsupervised.
- **WARNING:** Never leave water in the reservoir when the appliance is not in use, microorganisms can grow in stagnant water, the water tank should be emptied and cleaned regularly and properly. Empty the tank, clean and dry it when not in use and before putting into storage.
- **CAUTION:** Clean and empty the water tank at least every third day. Empty the water tank and clean it with fresh tap water or mild detergent. Remove any scale, deposits, or film that has formed on the sides of the water tank or on interior surfaces using soft non-abrasive cleaning agents (such as washing up liquid), wipe all surfaces dry on completion.
- **WARNING** – The water collected in the tank must never be used for drinking, it is not suitable for human, bird or animal consumption.
- Be aware that high humidity levels may encourage the growth of biological organisms in the environment.
- Monitor the area around the dehumidifier to ensure there is no damp or wet. Do not allow absorbent materials, such as carpeting, drapes, or tablecloths to become damp.
- Air inlet filter must be cleaned regularly to ensure correct operation and to avoid damage to the appliance.
- Never operate the product without the filter.
- **WARNING:** To avoid danger of suffocation please remove all packaging materials particularly plastic and EPS and keep these away from vulnerable people, children and babies.
- **WARNING:** To avoid the risk of accidental strangulation from the supply cord all children and vulnerable people must be supervised when in the vicinity of the product whether it is working or not.
- **NEVER** drop or insert any object into any openings.



Exposed to the weather outdoors



Near water



If the power cable wires are frayed or cut



Where small children may be left unattended

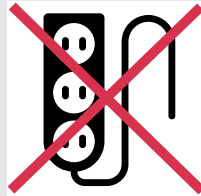

If an extension lead may become overload



Where the power cable may be damaged



On a slope or uneven surface



Where there is risk of fire or close to a naked flame



Where it may be damaged by chemicals



Where there is a risk of interference by foreign objects



This product is not made for DIY repair



If there is a risk of water falling on the unit

Specification

Model no.	10L	14L
Max Dehumidification capacity at 30°C, 80%	10L/day	14L/day
Max Dehumidification capacity at 21°C, 59%	3.3L/day	4.7L/day
Max Dehumidification capacity at 10°C, 59%	1.5L/day	1.5L/day
Working range	5 - 32°C	
Water tank	2.5 L	
Size (WxDxH)	300 x 204 x 459 mm	
N.W.	10.5 kg	11.5 kg
Power supply	220-240V~, 50Hz	
Standard Ampere consumption	1.5A	1.4A
Power Consumption (P) (W)	290W	280W
Standby Power Consumption (PSB) (W)	0.35W	0.35W
Sound Power Level (LWA) (dBA)	41.5dB(A)	41.5dB(A)
Maximum Air Velocity (c) (m/s)	19.1 m/s	19.1 m/s
Air volume (max.)	130M ³ /h	
Compressor	Reciprocating	
Maximum Suction Pressure (MPa)	0.85MPa	0.85MPa
Maximum Discharge Pressure (MPa)	2.2MPa	2.2MPa
Maximum Pressure of Coil (MPa)	9.6MPa	9.6MPa
Refrigerant	R290	
GWP	3	
Refrigerant Charge (kg)	0.035kg	0.065kg
CO ² Equivalent (tonnes)	0.000105 tonnes	0.000195 tonnes

Contains fluorinated greenhouse gases. Hermetically sealed system.

Contact details: **UK:** Glen Dimplex Heating & Ventilation, Grange Drive, Hedge End, Southampton SO30 2DF
ROI: Glen Dimplex Europe Limited, Airport Road, Cloghran, County Dublin, K67 VE08

- The data marked with * may vary for technical reasons. For greater precision, please refer to the rating label placed on the product.
- Test condition for data in our rating label is as per safety regulation: EN 60335-2-40
- Note that when the dehumidifier is in operation, the running compressor will produce heat, this is normal and may potentially raise the room temperature.

Quick start/ First time operation

1. Before switching on for first time please ensure unit has settled for 12 hours.
2. Please remove 'carbon filter' from its bag and locate between the anti- dust filter and air inlet on the body of the product (make sure carbon filter is lined up properly with guide locators on the air inlet).
3. Ensure pre filter and carbon filter is fitted securely to the product before switching on.

4. Plug product in.



5. Press on/off button.

6. Select the humidity control button and keep pressing until 'cont' lights up- this will set product to run continuously- leave to 3 minutes then adjust humidity control to your desired setting.

The lower the setting e.g 40% the product will try and target 40% relative humidity (ambient humidity) which is for drier conditions. Nearer 70% setting, the product will try and target 70% relative humidity e.g. more humid/ moist conditions. Unless this setting is changed, the product will now start controlling the ambient humidity in the room.

How It Works

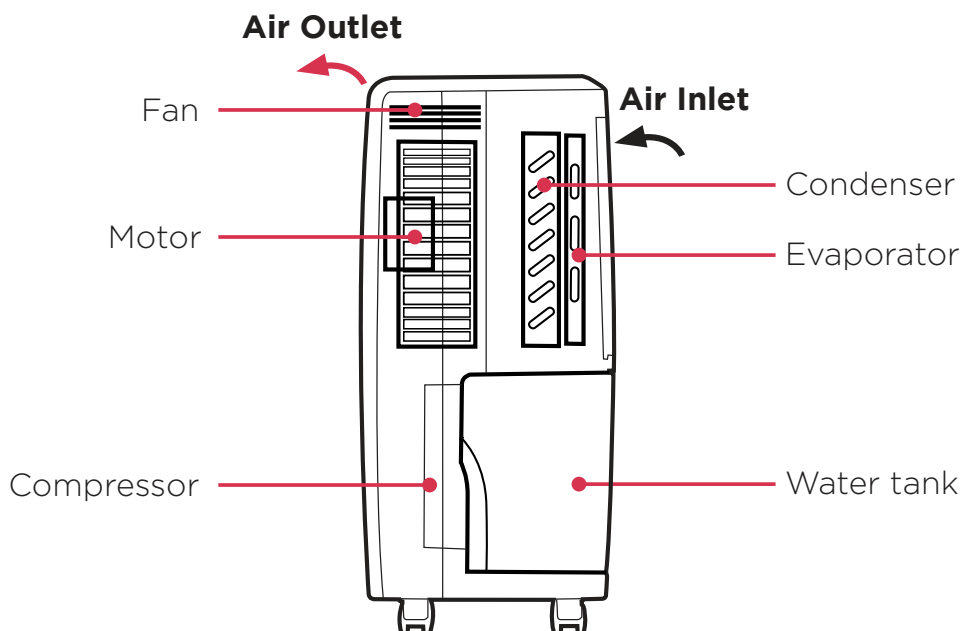

This product is a dehumidifier. It controls relative humidity by passing the air through the unit, forcing the excess moisture to condensate over the cooling elements.

Contact with this cold surface causes the moisture in the air to condense. This condensed water then drains safely into the water tank. The dried air then passes through the condenser where it is slightly warmed and re-enters the room at a slightly elevated temperature. N.B. As with all compressor type dehumidifiers their effectiveness is reduced the colder the ambient temperature is. Do not use where the ambient temperature is 5°C or lower.

Where To Position

Excess moisture will travel throughout your home, in the same way that cooking smells waft to every room in the house. For this reason, the dehumidifier should be positioned, so that it can draw this moist air towards it from all over the home.

Alternatively, if you have a serious problem in one area you can begin by positioning the dehumidifier close to this area and later moving it to a more central point.

When positioning the dehumidifier, ensure that it is placed on a level surface and that there is a minimum of 50 cm (20") of space on either side of the unit to allow for efficient airflow.

This dehumidifier is fitted with castors for extra mobility, if you move the unit, it should first be switched off and the water tank emptied. We do not recommend the use of an extension lead, so please try to ensure that the unit is sufficiently close to a fixed mains socket.

When the dehumidifier is in operation, outside doors and windows should be closed for most effective and efficient operation.

Parts

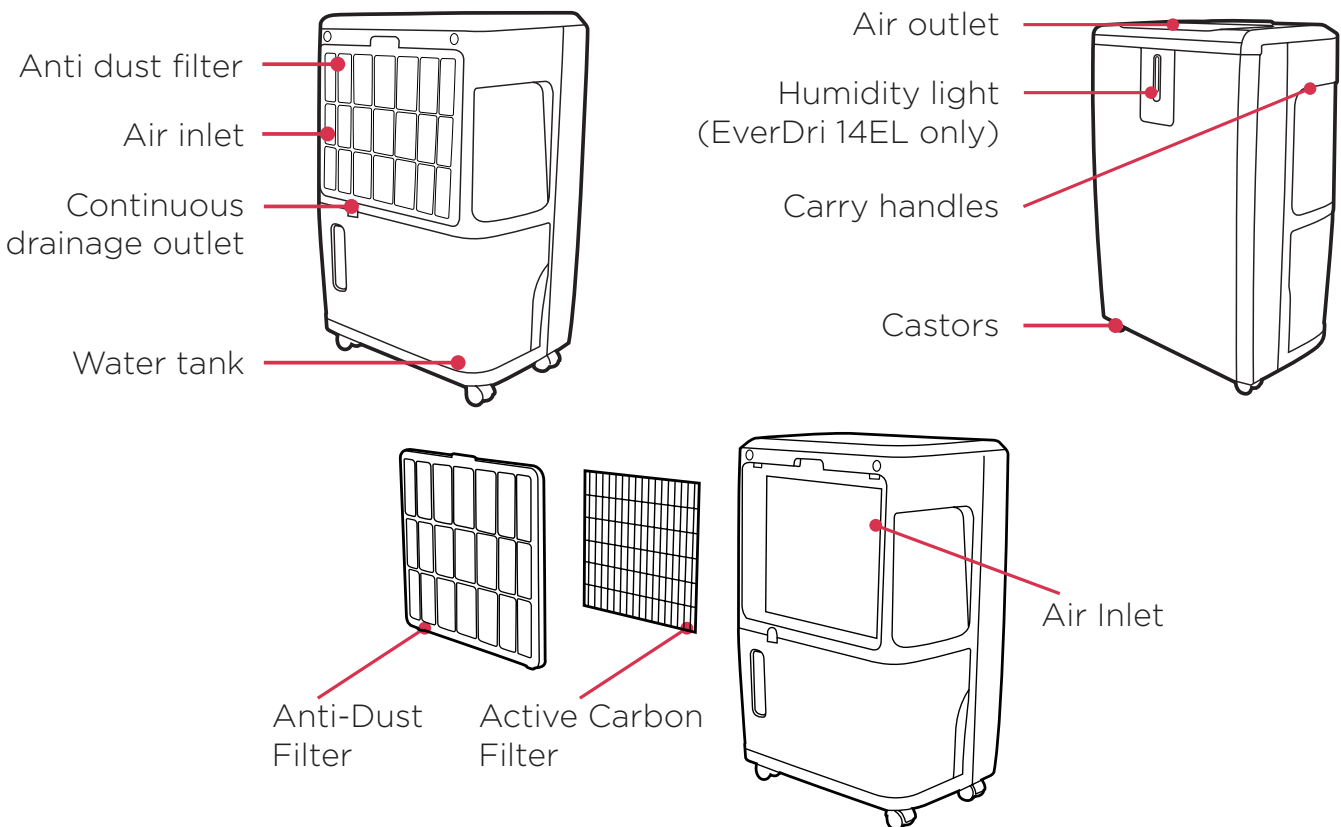

The Active Carbon Filter is used for capturing the smaller particles of dust suspended in the air and for tackling odours, absorbing formaldehyde, benzene and other noxious gases.

Comfort Humidity Light (EverDri14EL)

Blue light - room humidity > 70% (too moist)

Green light - room humidity 50-70% (Just right)

Red light - room humidity < 50% (Too dry)

Red light flashing - water tank full / tank not inserted correctly



EverDri14EL features a Comfort Humidity light on the front panel of the product. This is an extremely useful feature to provide a visual indicator as to the optimum 'comfort level' of humidity. It is designed to be a guide only, if you wish to keep the unit running when the light is red to tackle severe damp conditions then do so.

Control Panel and Operation (EverDri10E & EverDri14EL)

1. Power indicator
2. **ON/OFF** (power) button
3. Water tank “Full” indicator
4. Humidity setting button
5. Working mode indicator (continuous working, humidity 40%, 50%, 60%, 70%)
6. Timer operation indicator
7. Timer button

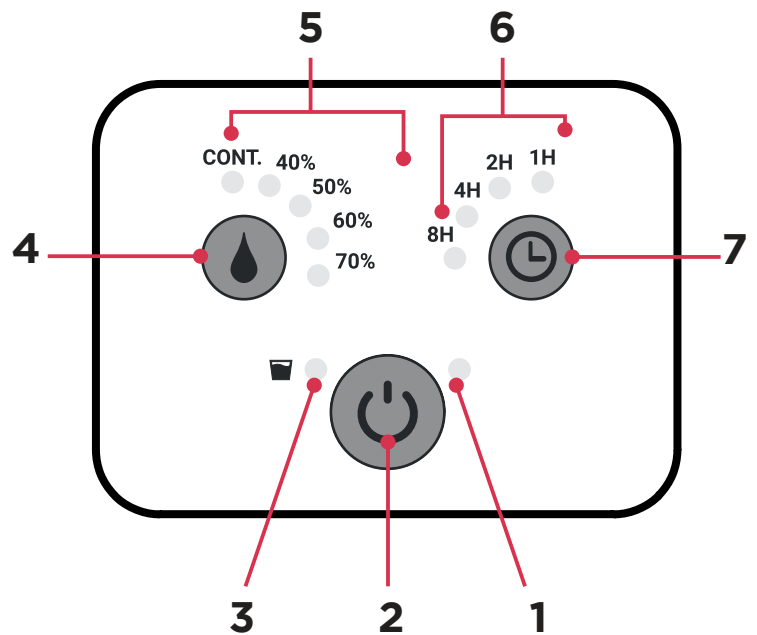

Steps:

1. Plug the unit into a correct mains socket. (Please refer to the rating label at the rear of the unit for correct voltage/frequency.)
2. Press **ON/OFF** button to turn on the unit. The power indicator will turn on and the compressor will start to work.
3. Press the humidity setting button to set the working mode you need: continuous working, humidity 40%, 50%, 60% or 70%. The relative indicator will light on. If you prefer dryer conditions (reduced humidity) set towards 40%. For more humid conditions set towards 70%. 'CONT' means the unit will be set to Continuous and will continue to run regardless of humidity level.
4. Press the **TIMER** button to set the operating time you need. There are 4 hour indicators above the **TIMER** button: 1, 2, 4, 8H. The time can be accumulated, so it's not just 4 different hours you could set. For example, choose 1 and 2 hours at the same time, the unit will work 3 hours continuously, choose 1, 2 and 4 hours at the same, it will work 7 hours. Thus, the timer could be set up to 15 hours. In this case all the hour indicator lights are illuminated. When the set time is reached, the dehumidifier will stop working automatically.
5. To turn off the unit, press **ON/OFF** button again.
6. Pre-setting function: By pressing the **TIMER** button without turning on the other functions (including **ON/OFF** button), you can **PRE-SET** the time for the product to switch on later. For example, if you press the timer to '2', the unit will switch on automatically after 2 hours.
7. When the water tank is full, the “Full Water” indicator will light up. Remove the water tank carefully, empty the water and replace securely ensuring snug fit.

Drainage

While the water tank is full, the compressor will stop for self-protection and the water tank full indicator light will turn red.

To move the water tank, pull it out squarely from the unit.

After emptying the water tank, place the water tank carefully back into its location into space. The tank must be properly located in order for the 'water full' light to go out and for your dehumidifier to start operating again.

Please note, if the water tank has not been positioned/located correctly, the water full indicator will stay red and the product will not operate.

CONTINUOUS DRAINAGE

When the dehumidifier is operated at very high humidity levels, the water tank will require more frequent emptying. In this situation, it may be more convenient to set the unit up for continuous drainage, this can be done as follows:

1. Pull out the water tank.
2. Connect a water drain tube of inner diameter 11 mm to the drain spout connection outlet at the top of the tank location area.

** Please note, the water tube is not supplied with the unit.*

3. Ensure the drain tube is fixed properly and that water will always drain away freely through the tube (the drain point/open end of the tube must be at a lower height than the drain outlet from the product).

Note! In very cold weather conditions, precautions should be taken to prevent the water tube from freezing.

4. Put the water tank back to its position.

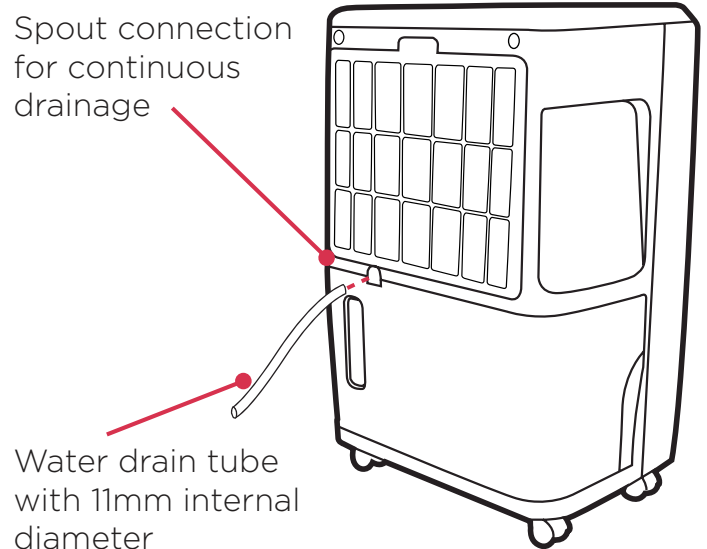

Always unplug the unit from the mains before carrying out any maintenance or cleaning of the unit.

CLEANING THE BODY

Use a soft damp cloth to wipe the unit clean.

Don't ever use volatile chemicals, gasoline, detergents, chemically treated clothes, or other cleansing solutions. These all could possibly damage the enclosure.

CLEANING THE FILTERS

This dehumidifier is equipped with 2 filters.

The plastic dust filter is washable and should be cleaned approximately every 2 weeks when in use (see instruction below).

The active carbon filter is not washable. The active carbon filter should be removed regularly and cleaned with a dry cloth. It should be placed in sunlight (on window sill) for a few hours every 3- 6 months to help re-charge the active carbon properties.

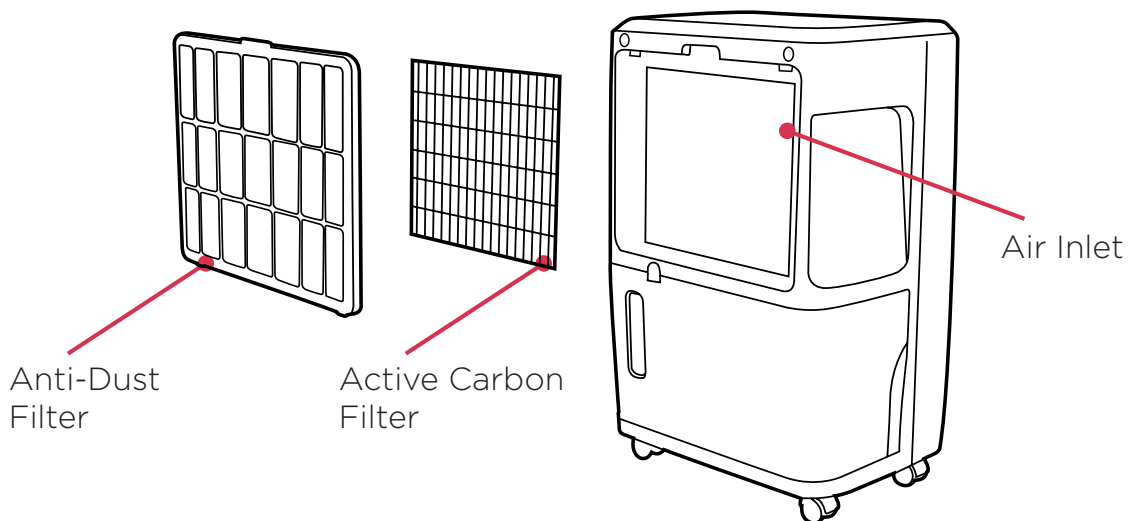

WASHING THE PLASTIC DUST FILTER

- Remove the anti-dust filter and separate the active carbon filter (not washable) and set it aside carefully.
- Use a vacuum cleaner or tap the plastic air filter lightly for easy cleaning. If the filter is particularly dirty, use warm water with a small amount of medium strength detergent to rinse the filter.
- Allow it to dry naturally and make sure the filter is completely dry before replacing.
- Do not expose the filter to sunlight.

STORAGE

If not using the unit for an extended period of time. Please:

- Turn the unit off, unplug and take care of the mains lead & plug.
- Completely empty the water tank and clean it thoroughly and wipe it dry.
- Cover the unit and store it upright in a location where it will not receive direct sunlight.
NB- Prolonged exposure to direct sunlight will discolour the enclosure.

THE UNIT DOES NOT OPERATE:

- Is the unit plugged in?
- Is the house electricity on?
- Is the room temperature below 5°C or above 32°C? If so, then it is out of the working range of the unit.
- Ensure the ON/OFF switch is turned on.
- Check the water tank is located properly in the unit and it is not full.
- Make sure the air inlet and outlet are not obstructed.

THE UNIT SEEMS TO DO NOTHING:

- Is the filter dusty, contaminated?
- Is the air intake or outlet blocked?
- Is the room humidity already quite low?

THE UNIT SEEMS TO DO LITTLE:

- Are too many windows or doors open?
- Is there something in the room producing lots of humidity?

THE UNIT IS TOO NOISY:

- Check whether the unit is sitting on a level surface.

THE UNIT IS LEAKING:

- Make sure the unit is on a level surface and the water tank is fitted correctly
- Check that the water tank is not damaged.

ERROR/ FAULT CODE MESSAGES ON DISPLAY:

- **1H** or **2H** Flashing – Sensor malfunction – Please stop using the product & Contact Customer Service.
- **4H** Flashing – Connection malfunction – Please stop using the product & Contact Customer Service.
- **8H** Flashing – Temperature elevated – Please disconnect from the mains for a few minutes and then reconnect, if the message reappears please stop using the product and contact Customer Service.

POWER LIGHT INDICATOR FLASHING:

Note: If the dehumidifier is continuously operating for long periods in an application where humidity levels are very high, or, the ambient temperature is very low, the evaporator coils (inside the back air inlet) may freeze up, when this happens a sensor will switch the product into defrost mode (turning off the compressor & leaving the fan running) and the power indicator light will flash on and off indicating the product is defrosting, once it has defrosted sufficiently the sensor will switch the compressor back on and the power indicator light will stop flashing.

Recycling

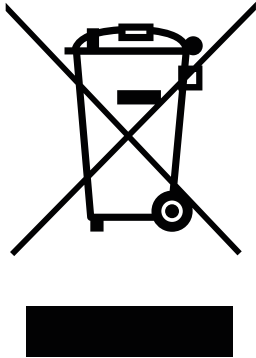

Recycling: For electrical products sold within the European Community. At the end of the electrical products useful life it should not be disposed of with household waste. Please recycle where facilities exist. Check with your Local Authority or retailer for recycling advice in your country.

If you don't intend to keep the packaging of this product for later use or storage, please dispose of it in an eco-friendly way, please dispose of it in your recycling bin or nearest recycling facility, thank you.

Spare parts

Selected replacement parts are available on www.dimplex.co.uk

What does a Dimplex Guarantee cover?

Dimplex products deliver reliable service for normal, household use in domestic settings. All Dimplex products are individually tested before leaving the factory.

If you are a consumer and you experience a problem with your Dimplex product, which is found to be defective due to faulty materials or workmanship within the guarantee period, this Dimplex guarantee will cover repair or - at the discretion of Dimplex - replacement with a functionally equivalent Dimplex product.

Your product is under guarantee for 1 year from the date of purchase or the date of delivery of the product, if later. The 1 year guarantee is extended for an additional 2 years when you register the product with Dimplex, within 28 days of purchase. If you do not register the product with Dimplex within 28 days, your product will remain guaranteed for 1 year only. To validate your extended guarantee register with us online at: <http://register.dimplex.co.uk>. N.B. Each qualifying product needs to be registered with Dimplex individually. Please note that the extended guarantee is only available in the UK and Ireland.

The Dimplex guarantee is conditional upon you providing the original purchase receipt as proof of purchase. Please therefore retain your receipt as proof of purchase.

If you do experience a problem with your Dimplex product please call the Helpline on +44 [0]344 879 3588 or visit <https://www.dimplex.co.uk/support>. For ROI please email serviceireland@glendimplex.com or call +353(0)1 842 4833. We will need details of your Dimplex product and a description of the fault which has occurred. Once we receive your information and proof of purchase we will contact you to make the necessary arrangements.

If your Dimplex product is not covered by this Dimplex guarantee there may be a charge to repair your product. However, we will contact you for agreement to any charges before any chargeable service is carried out.

What is not covered by a Dimplex Guarantee?

The Dimplex guarantee does not cover any of the following:

Any fault or damage to your Dimplex product due to faulty materials or workmanship occurring outside the guarantee period.

Normal wear and tear including parts that might wear out over time or consumables, such as filters. Any fault or damage occurring to any pre-owned Dimplex product or to any other equipment or property. Accidental damage to your Dimplex product or damage to your Dimplex product from external sources (for example, transit, weather, electrical outages or power surges). Fault or damage to your Dimplex product which is: Not due to faulty materials or workmanship or which is due to circumstances outside Dimplex's control. Caused by use of your Dimplex product for anything other than normal domestic household purposes in the country where it was purchased.

Caused by any misuse, abuse or negligent use of the Dimplex product, including but not limited to any failure to use it in accordance with the Operating Instructions supplied with the product. Caused by any failure to assemble, install clean and maintain your Dimplex product in accordance with the Operating Instructions supplied with the product unless this was carried out by Dimplex or its authorised dealers.

Caused by repairs or alterations to your Dimplex product not carried out by Dimplex service personnel or its authorised dealer(s). Caused by use of any consumables or spare parts for your Dimplex product which are not Dimplex specified.

Terms and Conditions

The Dimplex guarantee is valid for 1 calendar year, plus 2 if registered, from the date of purchase of your Dimplex product from a recognised retailer in the country of purchase and use, or the date of delivery of the product if later, always provided the original receipt has been retained and is produced as proof of purchase.

You must provide to Dimplex or its authorised agents on request the original receipt as proof of purchase and - if required by Dimplex - proof of delivery. If you are unable to provide this documentation, you will be required to pay for any repair work required. Any repair work under the Dimplex guarantee will be carried out by Dimplex or its authorised dealer(s) and any parts that are replaced will become the property of Dimplex. Any repairs performed under the Dimplex guarantee will not extend the guarantee period.

The Dimplex guarantee does not entitle you to recovery of any indirect or consequential loss or damage including but not limited to loss or damage to any other property.

The Dimplex guarantee is in addition to your statutory rights as a consumer and your statutory rights are not affected by this Dimplex guarantee.

Contact Dimplex A brand of the Glen Dimplex UK Limited, trading as Glen Dimplex Heating & Ventilation.

If you have any questions about what the Dimplex guarantee covers and does not cover or how to claim under the Dimplex guarantee, please contact us.

Customer Helpline: 0344 879 3588

www.dimplex.co.uk



UK: Glen Dimplex UK Ltd., Millbrook House, Grange Drive, Hedge End, Southampton SO30 2DF

ROI: Glen Dimplex Europe Limited, Airport Road, Cloghran, County Dublin, K67 VE08