

Contents

Contents	1		
Chapter 1. Summary.....	2	5.1 Input & Output Characteristics	11
1.1 General Description.....	2	5.1.1 Input Standby Power	11
1.2 Key Features	2	5.1.2 Power Conversion Efficiency at Different AC Line Input Voltage (PCB End).....	11
1.2.1 System Key Features	2	5.1.3 Output I – V Curve @ Board End.....	12
1.2.2 AP3302 Key Features.....	2		
1.2.3 APR34509 Key Features	2	5.2 Key Performance Waveforms	13
1.2.4 AP43331N Key Feature.....	2	5.2.1 18W QC3.0 System Start-up Time & Hold-up Time.....	13
1.3 Applications	2	5.2.2 Q1 and AP34509 Main Switching MOSFET Stress on at 12V/ 1.5A Loading @264Vac.....	13
1.4 Main Power Specifications (CV & CC Mode) ..	2	5.2.3 System Output Ripple & Noise with @ 1.2m Cable End.....	14
1.5 Evaluation Board Pictures.....	2		
Chapter 2. Power Supply Specification	3	5.3 Output Voltage Transition Time.....	15
2.1 Specification and Test Results.....	3	5.3.1 Dynamic load: The test condition	16
2.2 Compliance	3	5.3.2 Thermal Testing.....	17
		5.3.3 EMI (CE) Conductive Emission Testing	18
Chapter 3. Schematic.....	4		
3.1 EV1 Board Schematic.....	4		
3.2 Bill of Material (BOM)	5		
3.3 Transformer design.....	7		
3.4 Schematics Description	7		
3.4.1 AC Input Circuit & Differential Filter	7		
3.4.2 AP3302 PWM Controller	7		
3.4.3 APR34509 Mosfet Co-packaged Synchronous Rectification (SR) Switcher	7		
3.4.4 AP43331N QC3.0 Decoder Interface to Power Devices	8		
Chapter 4. The Evaluation Board (EVB) Connections.....	8		
4.1 EVB PCB Layout	8		
4.2 Quick Start Guide Before Connection.....	8		
4.3 System Setup	10		
4.3.1 QC 3.0 sample load connection + Test Kit.....	10		
4.3.2 QC3.0 test Kit test procedures .	10	Chapter 5.	
Testing the Evaluation Board	11		

Chapter 1. Summary

1.1 General Description

The 18W QC 3.0 charger Evaluation Board EV1 is composed of three main parts, AP3302 offers the QR/DCM PWM switching, APR34509 is an N-Mosfet SO-8EP co-packaged Synchronous Rectification Switcher, and the AP43331N performs QC 3.0 class A decoding function. Based on monitoring D+ & D- signals in USB Type A port, the AP43331N interprets desired voltage and current setting and provides the real time feedback information to primary side AP3302 controller for voltage regulation. The 18W QC3.0 quick charger reference design exemplifies the cost-effective performance-optimized QC3.0 charging solution.

1.2 Key Features

1.2.1 System Key Features

- SSR Topology Implementation with an Opto-coupler for Accurate Step Constant Voltage and Current Control
- QC 3.0 Compliance
- Meet DOE6 and CoC Tier 2 Efficiency Requirements
- <75mW No-Load Standby Power

1.2.2 AP3302 Key Features

- Quasi-Resonant Operation with Valley Lock under all Lines and Load Conditions
- Switching Frequency: 22kHz-120kHz
- Non-audible-noise QR Controlling
- Soft Start Process during the Start-up Turn-on Moment
- During the burst mode operation and Low start-up operating quiescent currents, 75mW standby power can be achieved
- Built-in Jittering Frequency Function which is the EMI emission can be improved
- Internal Auto Recovery OCP, OVP, OLP, OTP Power Protection, cycle by cycle current limit, also with DC polarity & transformer short and Brown out Protection

1.2.3 APR34509 Key Features

- Co-package (SO-8EP) N-Mosfet and synchronous rectification controller IC
- Synchronous Rectification supporting the DCM,CCM mode and QR Flyback
- Eliminate Resonant Ringing Interference
- Fewest External Components used & the total SR space reduced.

1.2.4 AP43331N Key Feature

- Supporting Qualcomm QC 3.0 and QC2.0
- Built in Shunt Regulator for Constant Voltage and Constant Current
- Programmable OVP/UVP/OCP/OTP
- Internal Discharge MOS
- Certified Qualcomm QC3.0 protocol spec (UL Report Number – 4787662260-1, 3/22/2017)
- Output cable voltage compensation

1.3 Applications

- 18W QC3.0 Quick Charge

1.4 Main Power Specifications (CV & CC Mode)

Parameter	Value
Input Voltage	90Vac to 264Vac
Input standby power	< 75mW
Main Output Vo / Io	QC2.0: 5V/3A, 9V/2A, 12V/1.5A, QC3.0: 3.6V ~12V, Io <3A,
Efficiency	87.5%
Voltage step	+ / - 0.2V
Total constant Output Power	<= 18W
Protections	OVP, UVP, OLP, BNO, FOCP, SSCP, OTP
XYZ Dimension	37 x 39 x 20 mm
ROHS Compliance	Yes

1.5 Evaluation Board Pictures



Figure 1: Top View



Figure 2: Bottom View

Chapter 2. Power Supply Specification

2.1 Specification and Test Results

Parameter	Test conditions	Min	Nom	Max	Eff / DoE VI	Eff / Tier2	Test Summary
V _{in} Input Voltage		90 V _{max}	115/230	264 V _{max}			
F _{in} Frequency		47 Hz	50/60	64 Hz			
I _{in} Input Current				0.8 A _{max}			Pass
No load Pin	At 230Vac _{in} , 50Hz, @ 5V, Pin < 75mW			75mW			Pass, the test result is 48mW
5V/3A @115Vac/230Vac Average efficiency	Board end		5V/3A		81.39%	81.84%	Pass, average efficiency is 86.4%
5V/3A @115Vac/230Vac 10% efficiency	Board end		5V/0.3A			72.48%	Pass, efficiency is 83.1%
9V/2A @115Vac/230Vac Average efficiency	Board end		9V/2A		85.0%	85.45%	Pass, average efficiency is 87.85%
9V/2A @115Vac/230Vac 10% efficiency	Board end		9V/0.2A			75.45%	Pass, efficiency is 83.4%
12V/1.5A @115Vac/230Vac Average efficiency	Board end		12V/1.5A		85.0%	85.45%	Pass, average efficiency is 88.89%
12V/1.5A @115Vac/230Vac 10% efficiency	Board end		12V/0.15A			75.45%	Pass, efficiency is 79.3%

2.2 Compliance

Parameter	Test conditions	Min	Nom	Max	Test Summary
Standby Power (mW)	5V Output			75m W	Pass
Output Voltage Tolerance	5V/0-3A	4.75V	5V	5.25V	Pass
Output Voltage Tolerance	9V/0-2A	8.55V	9V	9.45V	Pass
Output Voltage Tolerance	12V/0-1.5A	11.4V	12V	12.6V	Pass
Output Connector	USB Type A				
Temperature	90Vac, 9V / 2A				Pass
Dimensions (W/D/H)	37mm x 39mm x 20mm				
Safety	IEC/EN/UL 60950 Standard				
EMI/EMC	FCC/EN55022 Class B				Pass

Chapter 3. Schematic

3.1 EV1 Board Schematic

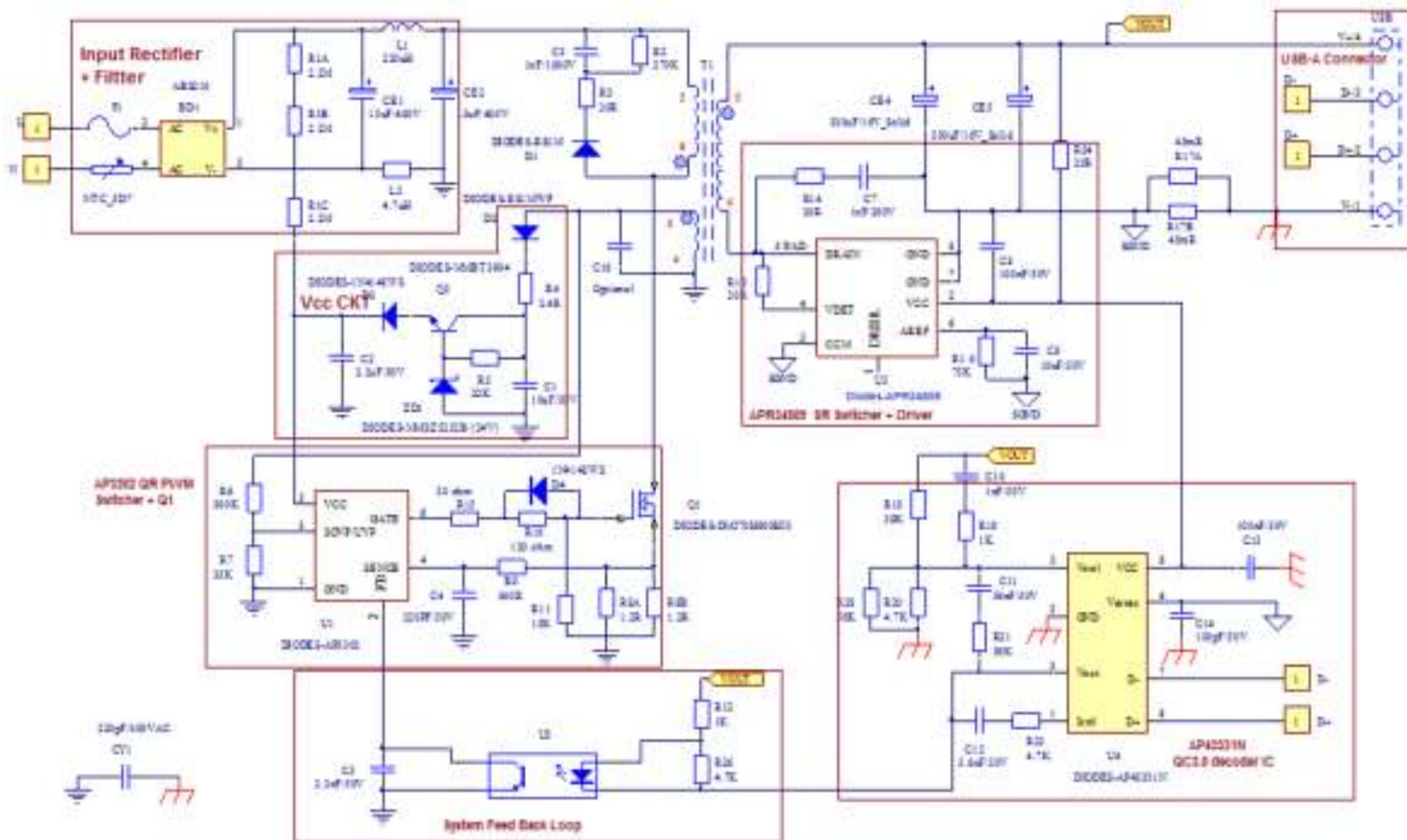

Figure 3: Evaluation Board Schematic

3.2 Bill of Material (BOM)

Designator	Comment	Footprint	Quantity	Remark
BD1	ABS210	D-46_6A	1	
C1	10uF/50V	0805	1	
C2	2.2uF	0805	1	
C3	1nF/1000V	0805	1	
C4	220PF/16V	0603	1	
C5	2.2nF/16V	0603	1	
C7	1nF/100V	0603	1	
C10	1nF/25V	0603	1	
C8, C13	100nF/25V	0603	2	
C9	10nF/25V	0603	1	
C11	56nF/25V	0603	1	
C12	5.6nF/25V	0603	1	
C14	100pF/16V	0603	1	
C16	Optional			
CE1, CE2	15uF/400V E-Cap	CE5-D10	2	
CE4	330uF/16V,Solid Cap	CE5-D5	1	
CE5	470uF/16V,Solid Cap	CE5-D5	1	
CY1	220pF	CY7.5	1	
D1	US1M	SMA	1	
D2	RS1MWF	SOD123F	1	
D3,D4	1N4148W	SOD323	2	
F1	3.15A/300VAC	Fuse-P5.0	1	
L1	DM Chock, D5, 220uH	LD-D4.5XP2.5	1	
L2	4.7uH	0805	1	
NTC	5D-7	C5-3X8	1	
Q1	DIODES-DMJ70H900HJ3 Vds=700VDC, Rds_on =0.9ohm	TO-251	1	DMJ70H900HJ



18W QC3.0 SSR Premium Charge EV1 Board User Guide

Designator	Comment	Footprint	Quantity	Remark
Q2	MMBT3904	SOT-23	1	
R1A, R1B, R1C	2.2M ohm	0805	3	
R2	270K	1206	1	
R3	20R	1206	1	
R4	2.4R	0805	1	
R5 , R11	15K	0603	2	
R6	300K	0603	1	
R7	33K	0603	1	
R8A,R8B	1.2R	0805	2	
R9	560R	0603	1	
R10	120 ohm	0603	1	
R15	20 ohm	0603	1	
R12, R19	1K	0603	2	
R13, R14, R24	20R	0603	3	
R16	75K	0603	1	
R17A, R17B	45 mohm	1206	2	
R18	39K	0603	1	
R20, R22, R26	4.7K	0603	3	
R21, R28	56K	0603	2	
U1	AP3302	SOT26	1	
U3	TCLT1006	OP817-SOD	1	Or PIC817
U4	AP43331N	SO-8	1	
U5	APR34509	SO-8EP	1	
ZD1	MMSZ5251B,24V Zener Doide	SOD123	1	
USB	USB CLASS A Connector	USB-A	1	
T1	PQ2016 Low Height Bobin ,H=12mm	PQ2016D	1	
PCB	37mm*39mm double-side		1	

3.3 Transformer design

PQ2016 (Ae=64mm²) Height=12mm						
NO	NAME	TERMINAL NO.		WINDING		
		START	FINISH	WIRE	TURNS	Layers
1	Np1	8	7	Φ 0.23*1	45	3
2	Na	3	4 (GND)	Φ 0.18*1	18	1
3	Shield	4 (GND)	NC	Φ 0.13*1	5	疏绕
4	Ns	5	6	Φ 0.65 TIW *1	6	2
5	Shield	4 (GND)	NC	Φ 0.13*1	Full	1
6	Np2	7	2 (VBUS)	Φ 0.23*1	20	2

Primary Inductance	Pin 8-2, all other windings open, measured at 1kHz, 0.4VRMS	950uH, ±5%
Primary Leakage Inductance	Pin 8-2, all other windings shorted, measured at 10kHz, 0.4VRMS	20 uH (Max.)

3.4 Schematics Description

3.4.1 AC Input Circuit & Differential Filter

There are three components in the section. The Fuse F1 protects against over-current conditions which occur when some main components failed. The line filter is consisted of L1, L2 & two bulk caps CE1 & CE2, it will block the switching noise back to AC line. The BD1 is rectifier, and basically converts alternating current & voltage into direct current & voltage.

3.4.2 AP3302 PWM Controller

The AP3302 PWM controller U1 & Opto-Coupler U3 and Q1 are the power converting core components. The R1A, R1B, R1C resistor path will provide start-up voltage and current during starting up through Vcc (Pin 5). The subsequent VCC power will be provided by voltage feedback from the auxiliary winding through D2, D3, Q2, R4, R5, ZD1 regulator circuit. This design is to accommodate with the required wide voltage range to support QC3.0 various protocols from 3.6V to 12V.

Based on feedback of secondary side from Pin 3 of AP43331N Decoder to primary side FB pin of AP3302 through Opto-coupler U3, the AP3302 PWM controller will switch Q1 ON and Off by certain duty cycle to regulate desired voltage and current on the secondary side.

3.4.3 APR34509 Mosfet Co-packaged Synchronous Rectification (SR) Switcher

APR34509 operates in DCM mode in this design and drive the internal MOSFET based on the secondary side transformer on/off duty cycle.

3.4.4 AP43331N QC3.0 Decoder Interface to Power Devices

AP43331N is highly integrated secondary side constant voltage (CV) and constant current (CC) controller with QC3.0 decoder.

- 1) **D+ & D- (Pin 7, 8):** D+ & D- pin voltage are defined by QC3.0 spec to provide the channel communication link between power AC source and sink devices.
- 2) **Constant Voltage (CV):** The CV is implemented by sensing the ratio of R20 & R18 voltage (pin 5) and comparing with internal reference voltage to generate a CV compensation signal on the pin 3. There is a voltage loop compensation circuit C11 & R21 between Pin5 & Pin3, the fast voltage response can be obtained by adjusting their value. The output voltages can be adjusted by firmware programming.
- 3) **Constant Current (CC):** The CC is implemented by sensing the voltage across current sense resistor (R17A & R18B) and current sense amplifier, then comparing with internal programmable reference voltage to generate a compensation signal on the pin3.
- 4) **CC Loop Compensation:** between Pin3 & Pin1's C12, R22 are for the current loop compensation circuit.
- 5) **Vout Pin 3:** It is the key interface link from secondary decoder (AP43331N) to primary regulation circuit (AP3302). It is connected to Opto-coupler through U3 for feedback information based all sensed D+ & D- voltage status for getting desired output charging voltage & current.

Chapter 4. The Evaluation Board (EVB) Connections

4.1 EVB PCB Layout

The thickness for both sides of PCB board trace cooper is 2 Oz.

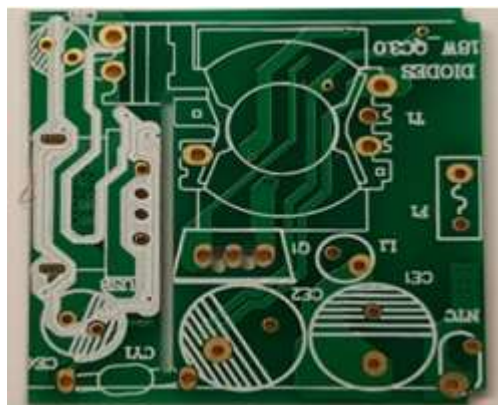

Figure 4: PCB Board Layout Top View

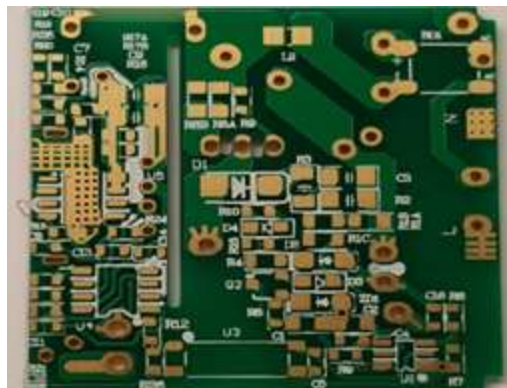

Figure 5: PCB Board Layout Bottom View

4.2 Quick Start Guide Before Connection

- 1) Before starting the 18W QC3.0 EVB test, the end user needs to prepare the following tool. For details,
 - Test Kit: Diodes 18W QC3.0 & 2.0 Test Kit

QC2.0 & QC3.0 test Kit

USB-A to Micro-B Cable

Connect to Charger output

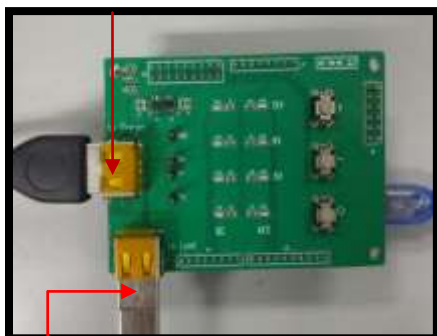

Connect to Load

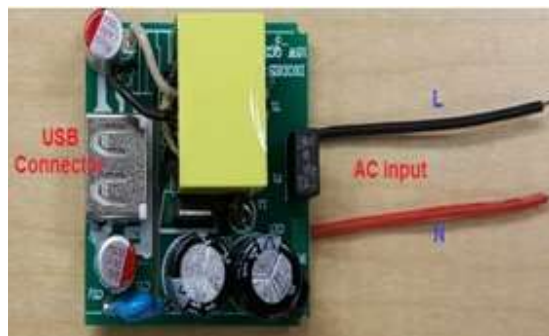

Figure 6: Test Kit

Figure 7 Test Cable

Figure 8: The QC3.0 Board Input & Output

- 2) Prepare a one-foot USB 3.0 - Micro B cable and a one side cut USB-3.0 Cable to the E-load.
- 3) Connect the sample input AC L & N wires to AC power supply output "L and N "wires.
- 4) Ensure that the AC source is switched OFF or disconnected before the connection steps.
- 5) Use 2 banana jack cables, one port of the cables are connected to E-load + & - terminals while the other port Of the cables
- 6) Or use a smart phone instead of E-load to connected with A Standard-A to Micro-B cable output



Figure 9: the connection between the 18W QC3.0 Evaluation Board to a QC3.0-equipped smart phone

4.3 System Setup

4.3.1 QC 3.0 sample load connection + Test Kit



Figure 10: The Test Kit Input & Output and E-load Connections

4.3.2 QC3.0 test Kit test procedures

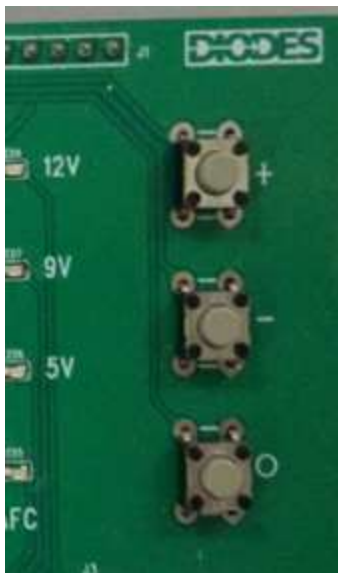

- The charger output default setting is 5V when was turned on
- Chose mode of QC2.0 or QC3.0 by pushing O button
- If in QC2.0 mode, the charger output will be increased To 9V or 12V when push the "+" button once time from 5V And the charger voltage will be decreased to 9V then to 5V from 12V when push the "-" button once time
- If in QC3.0 mode, the charger voltage will be increased by 200mV/per step when push the "+" button once time until from 3.6V to 12V
- If in QC3.0 mode, the charger voltage will be decreased by 200mV/per step when push the "-" button once time from 12V to 3.6V

Figure 11: The Test Kit test Buttons

Chapter 5. Testing the Evaluation Board

5.1 Input & Output Characteristics

5.1.1 Input Standby Power

Output Voltage	Input Voltage	Standby Power (mW)
5V	85	31
	115	33
	230	48
	264	62

5.1.2 Power Conversion Efficiency at Different AC Line Input Voltage (PCB End)

Vin	Vo	25%	50%	75%	100%	Average Efficiency	Energy Star Level VI	10% load efficiency
115VAC/60HZ	5.0V	87.67	87.5	86.02	84.47	86.42	>81.39%	86.83
230VAC/60HZ	5.0V	86.88	87.56	86.66	85.94	86.76		83.17
115VAC/60HZ	9.0V	88.07	88.2	87.82	87.34	87.85	>85.00%	85.84
230VAC/60HZ	9.0V	87.82	88.8	88.96	88.78	88.59		83.43
115VAC/60HZ	12.0V	87.06	88.09	87.95	87.85	87.74	>85.00%	81.17
230VAC/60HZ	12.0V	86.91	88.79	89.14	89.28	88.53		79.29

5.1.3 Output I – V Curve @ Board End

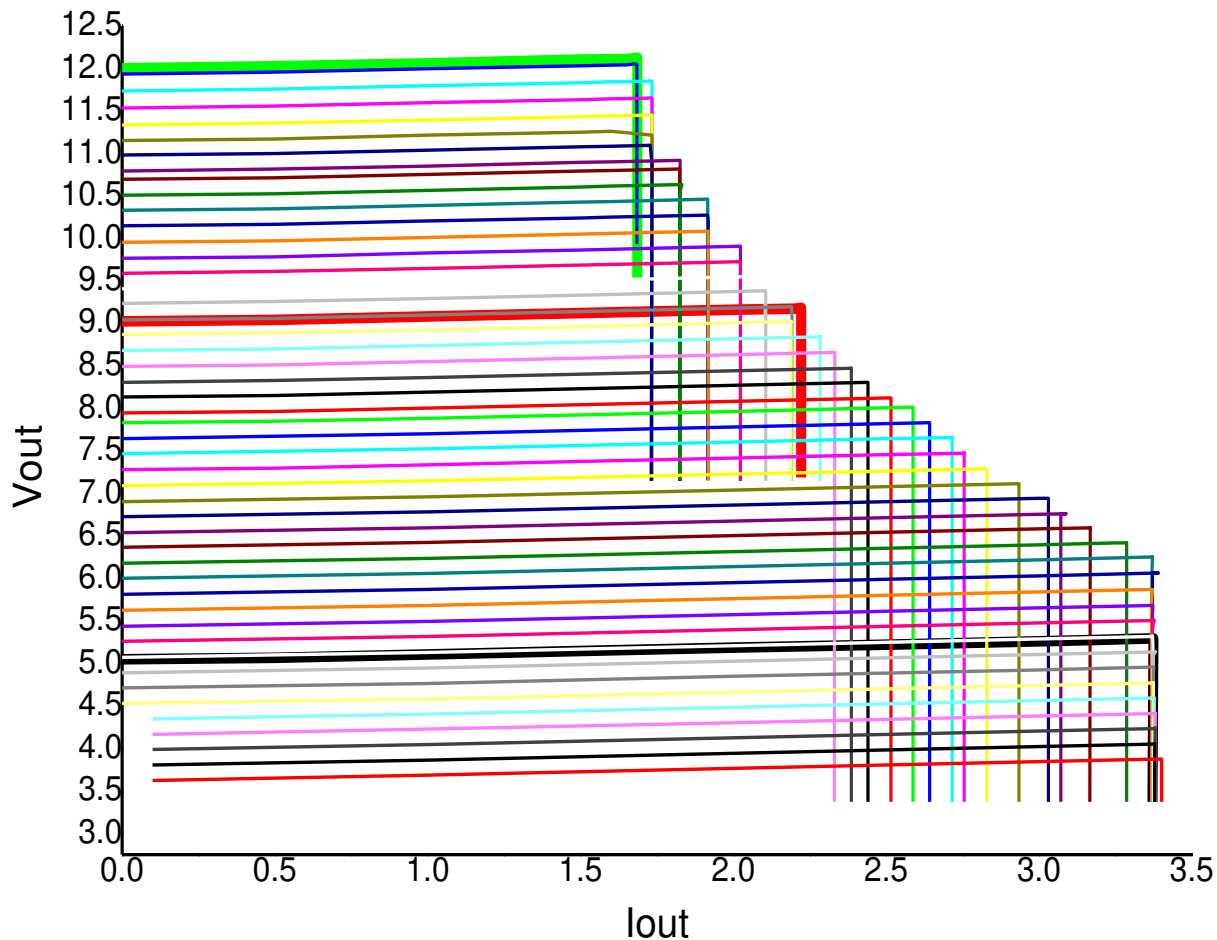

5.2 Key Performance Waveforms

5.2.1 18W QC3.0 System Start-up Time & Hold-up Time

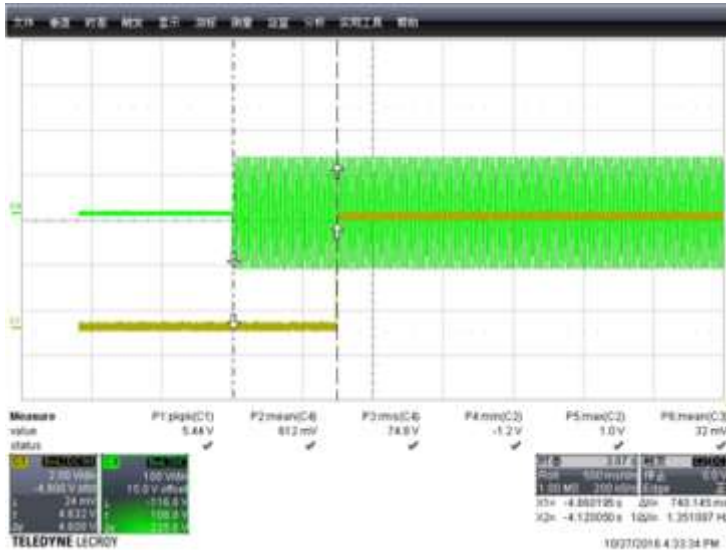

Figure 12: 18W QC 3.0 turn on time 0.27s 15V/3A at 90Vac

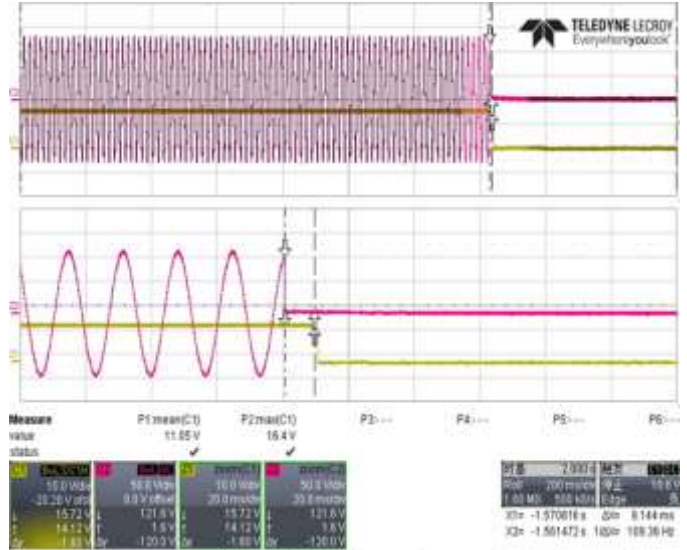

Figure 13: 18W QC3.0 hold time 9.14ms at 15V- 3A, at 90Vac

5.2.2 Q1 and AP34509 Main Switching MOSFET Stress on at 12V/ 1.5A Loading @264Vac

Primary side mosfet-Q1

Secondary side SR –AP34509 U3

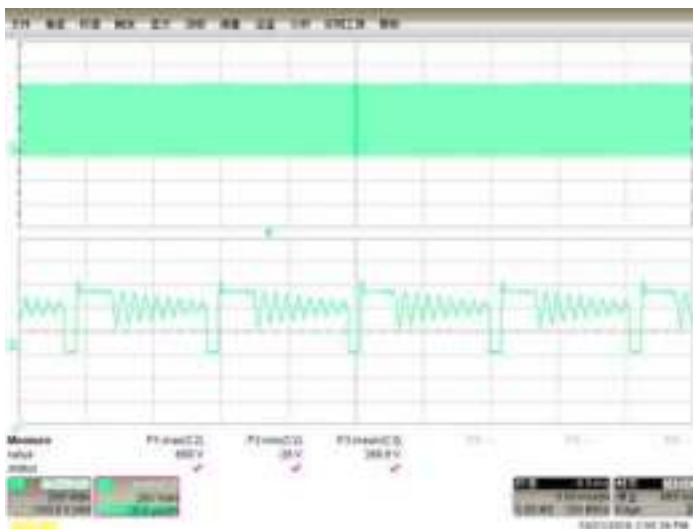

Figure 14

Vout	Vds(V)
12V	606 / 700V



Figure 15

Vout	Vdiode(V) peak
12V	55.7 / 60V

5.2.3 System Output Ripple & Noise with @ 1.2m Cable End

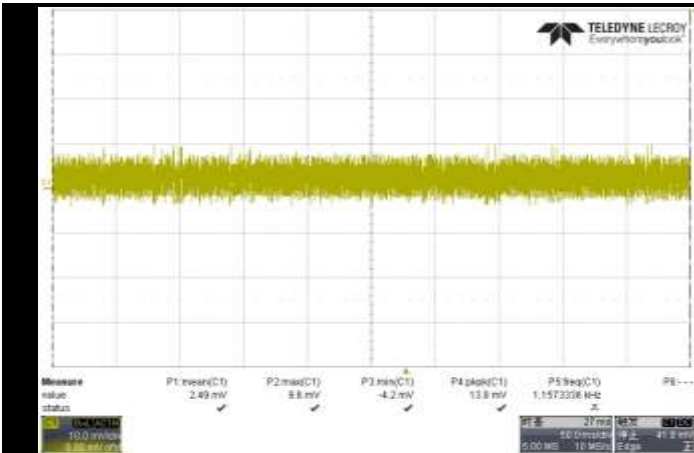

Figure 16: The Ripple at 90Vac/60Hz $\Delta V=14\text{mV}$ **5V/0A**

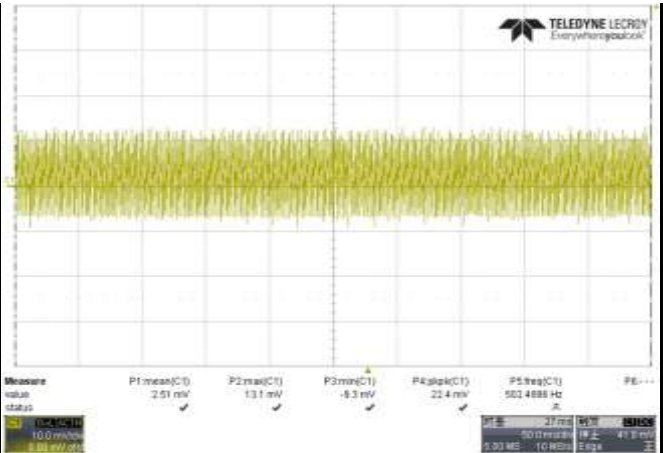

Figure 17: The Ripple at 264Vac/50Hz $\Delta V=23\text{mV}$ **5V/0A**

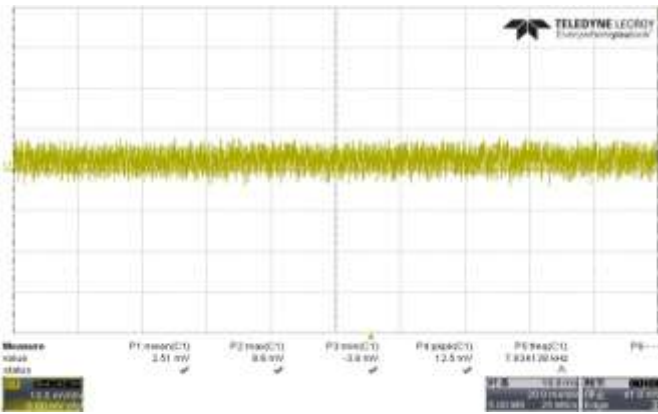

Figure 18: The Ripple at 90Vac/60Hz $\Delta V=13\text{mV}$ **9V/0A**

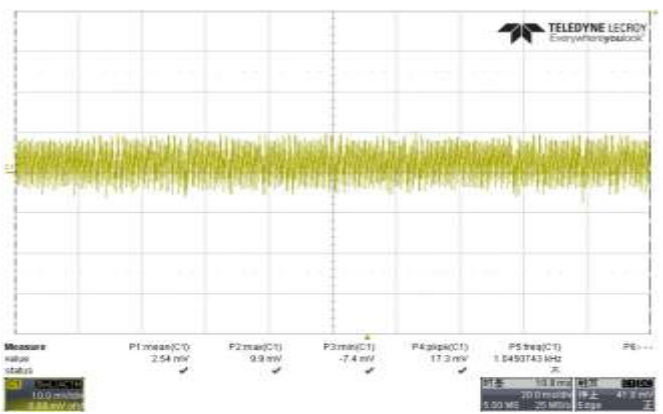

Figure 19: The Ripple at 264Vac/50Hz $\Delta V=18\text{mV}$ **9V/0A**

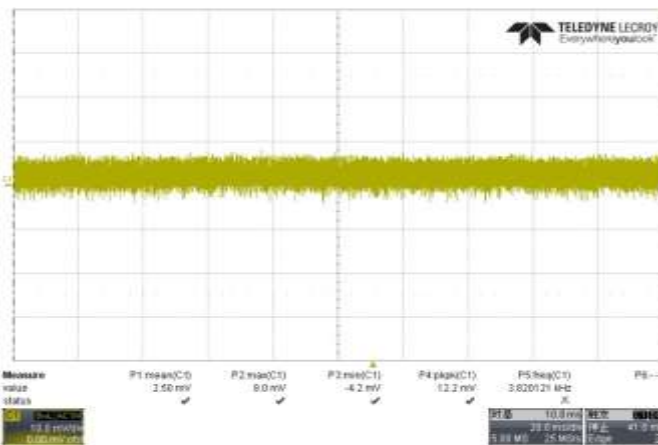

Figure 20: The Ripple at 90Vac/60Hz $\Delta V=12\text{mV}$ **12V/0A**

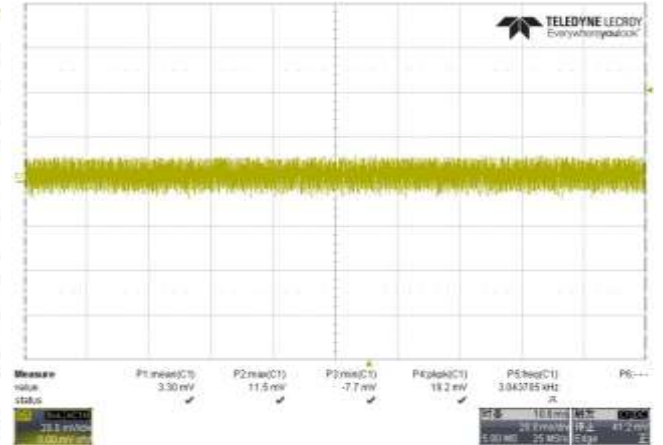

Figure 21: The Ripple at 264Vac/50Hz $\Delta V=19\text{mV}$ **12V/0A**

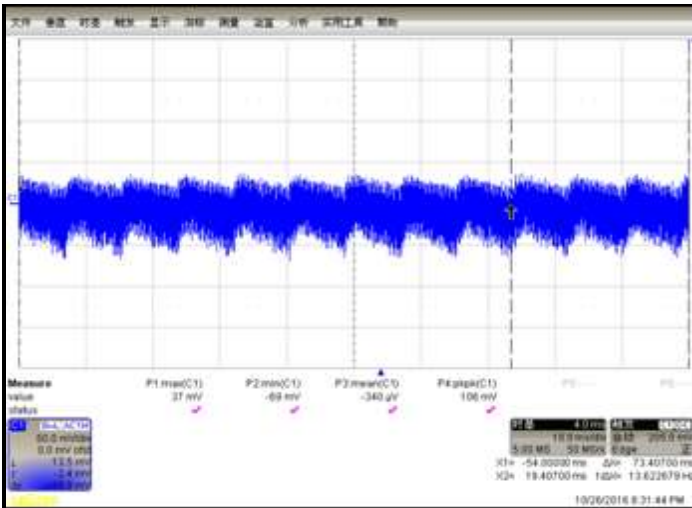

Figure 22: 90Vac/60Hz 5V/3A $\Delta V=106\text{mV}$

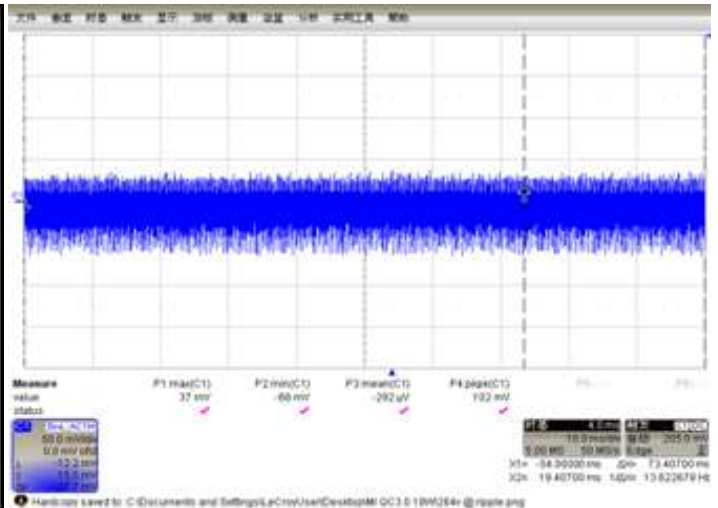

Figure 23: 264Vac/50Hz 5V/3A $\Delta V=102\text{mV}$

5.3 Output Voltage Transition Time

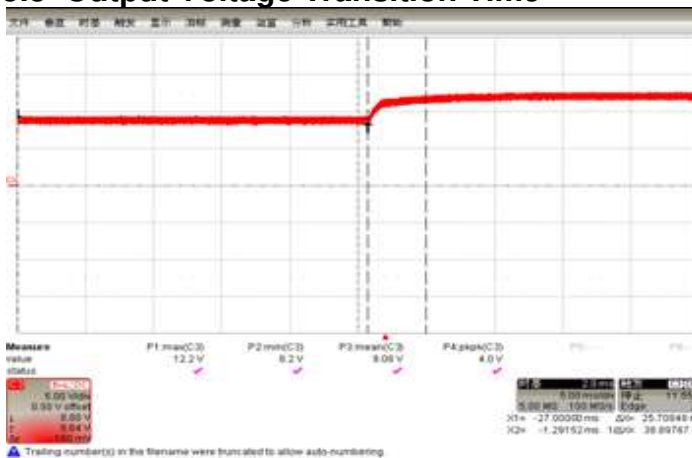

Figure 24: 90Vac/60Hz 5v – 9V

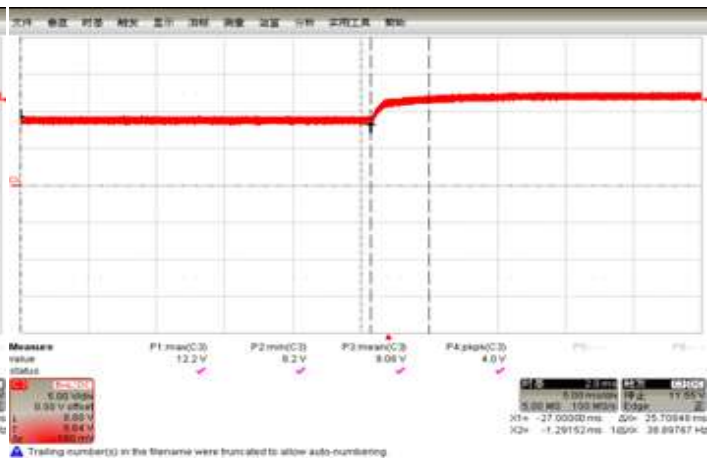

Figure 25: 90Vac/60Hz 9v – 12V

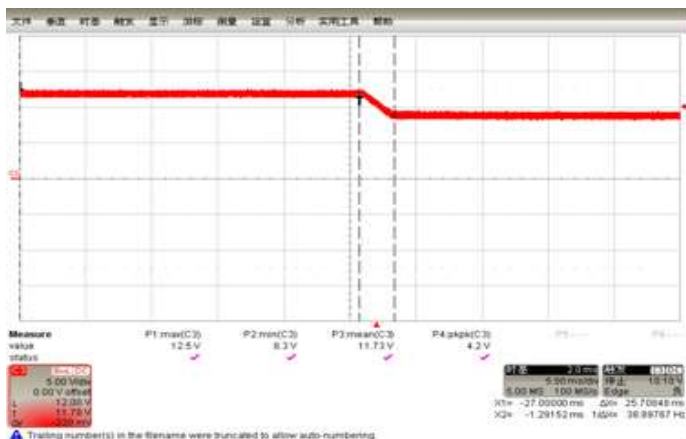

Figure 26: 90Vac/60Hz 12v – 9V

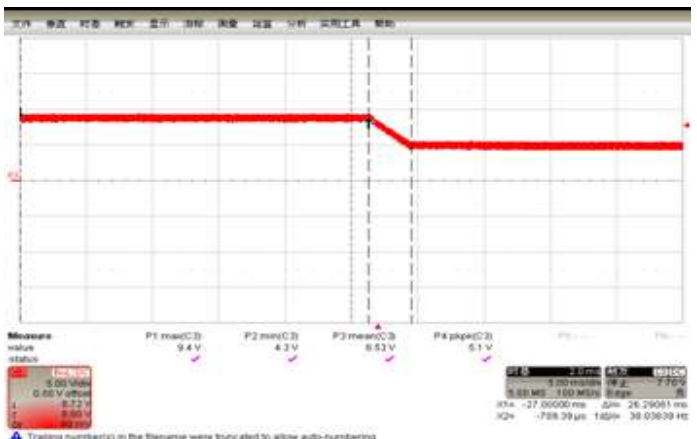

Figure 27: 90Vac/60Hz 9v – 5V

5.3.1 Dynamic load: The test condition

5V Dynamic loading between 10% ~ 90% of 3A, $F_d = 250\text{mA}/\mu\text{s}$ 50% duty $T_r = 1\text{ms}$

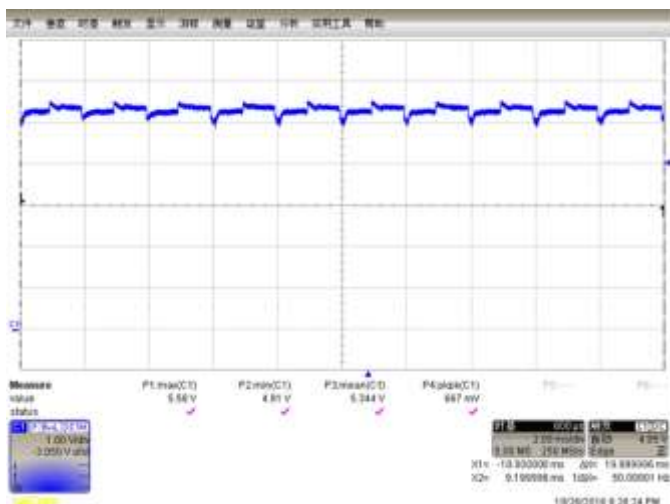

Fig 28: $V_{in} = 90\text{Vac}$ $V_{min} = 4.91\text{V}$ $V_{max} = 5.58\text{V}$

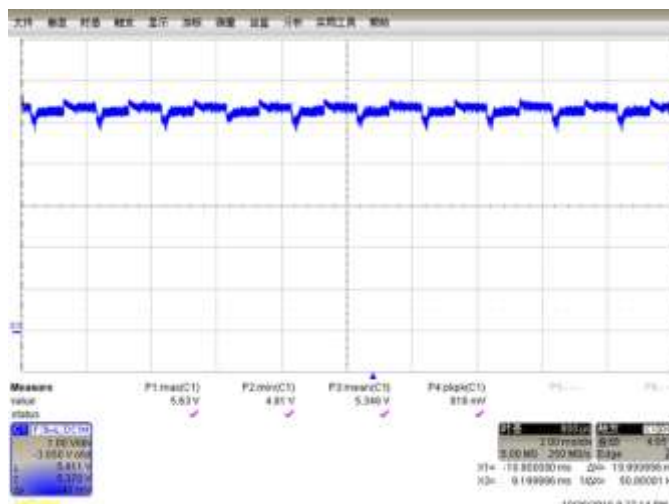

Fig 29: $V_{in} = 264\text{Vac}$ $V_{min} = 4.81\text{V}$ $V_{max} = 5.63\text{V}$

5V Dynamic Load

Loading	10ms-10ms		100ms-100ms		200ms-200ms	
	V_{o_min}	V_{o_max}	V_{o_min}	V_{o_max}	V_{o_min}	V_{o_max}
0-->100%	4.81	5.51	5.04	5.5	4.99	5.5
0-->50%	4.96	5.33	5.04	5.32	5.01	5.32
10-->90%	4.92	5.43	4.91	5.44	4.88	5.42

9V Dynamic Load

Loading	10ms-10ms		100ms-100ms		200ms-200ms	
	V_{o_min}	V_{o_max}	V_{o_min}	V_{o_max}	V_{o_min}	V_{o_max}
0-->100%	8.85	9.38	8.97	9.39	8.95	9.39
0-->50%	8.91	9.24	8.98	9.27	8.95	9.25
10-->90%	8.89	9.35	8.9	9.33	8.89	9.32

12V Dynamic Load

Loading	10ms-10ms		100ms-100ms		200ms-200ms	
	V_{o_min}	V_{o_max}	V_{o_min}	V_{o_max}	V_{o_min}	V_{o_max}
0-->100%	11.77	12.24	11.9	12.25	11.88	12.25
0-->50%	11.82	12.17	11.89	12.17	11.88	12.16
10-->90%	11.85	12.21	11.84	12.23	11.82	12.2

5.3.2 Thermal Testing

Test Condition: $V_{in}=90V_{ac}$ & $264V_{ac}$ $V_o=9.0V$ $I_o=2.0A$ Open Frame

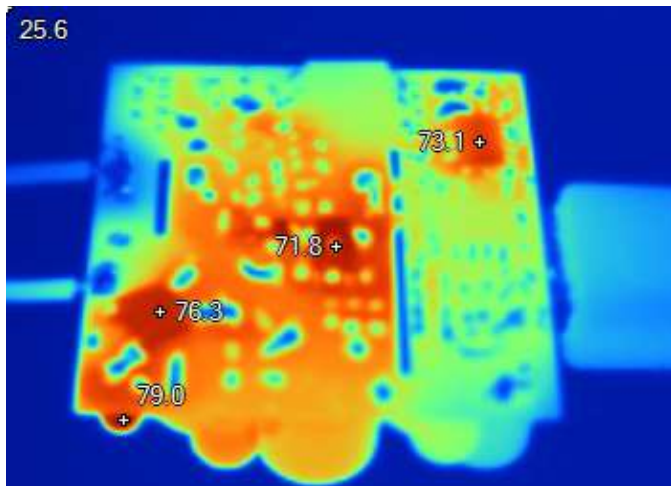

Figure 30: Surface Mount side at 90Vac 9V-2A

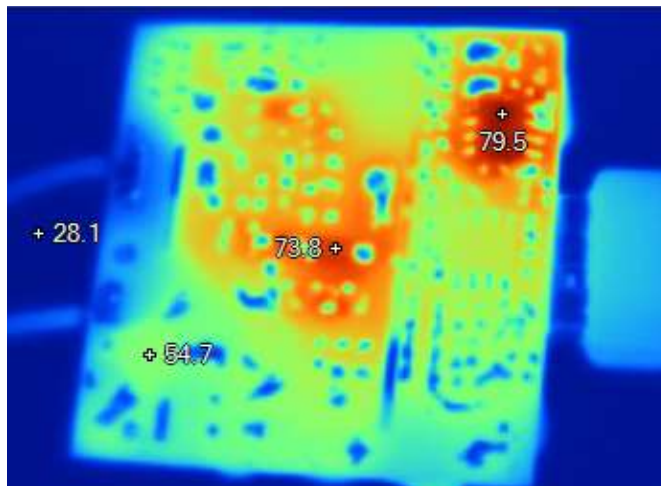

Figure 31: surface mount side at 264Vac 9V-2A

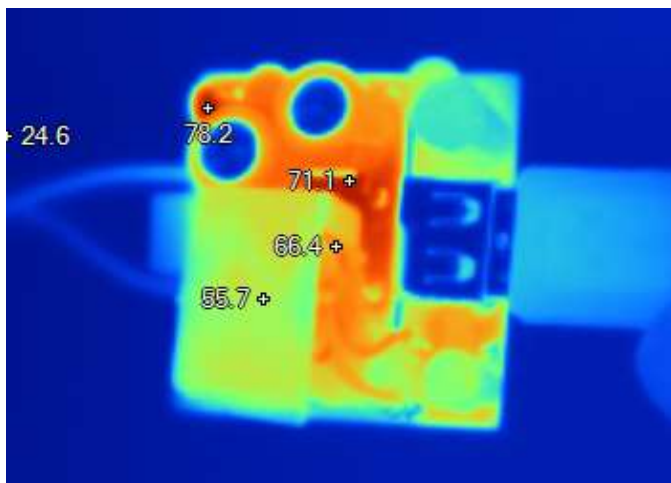

Figure 32: components side at 90Vac 9V-2A

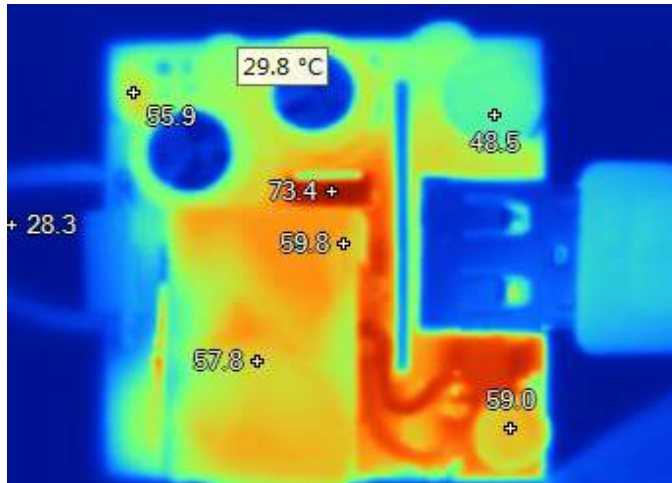

Figure 33: components side at 264Vac 9V-2A

Test Items	Unit	Temperature
Transformer wire	°C	66.6
Transformer core	°C	55.7
Primary Switching MOSFET	°C	71.1
Secondary Rectifier	°C	73.1
Ambient Temp	°C	25

Test Items	Unit	Temperature
Transformer wire	°C	59.8
Transformer core	°C	57.8
Primary Switching MOSFET	°C	73.4
Secondary Rectifier	°C	79.5
Ambient Temp	°C	25

5.3.3 EMI (CE) Conductive Emission Testing

Test Condition: $V_{in}=230V_{ac}$, $V_o=12V$, $I_o=1.5A$

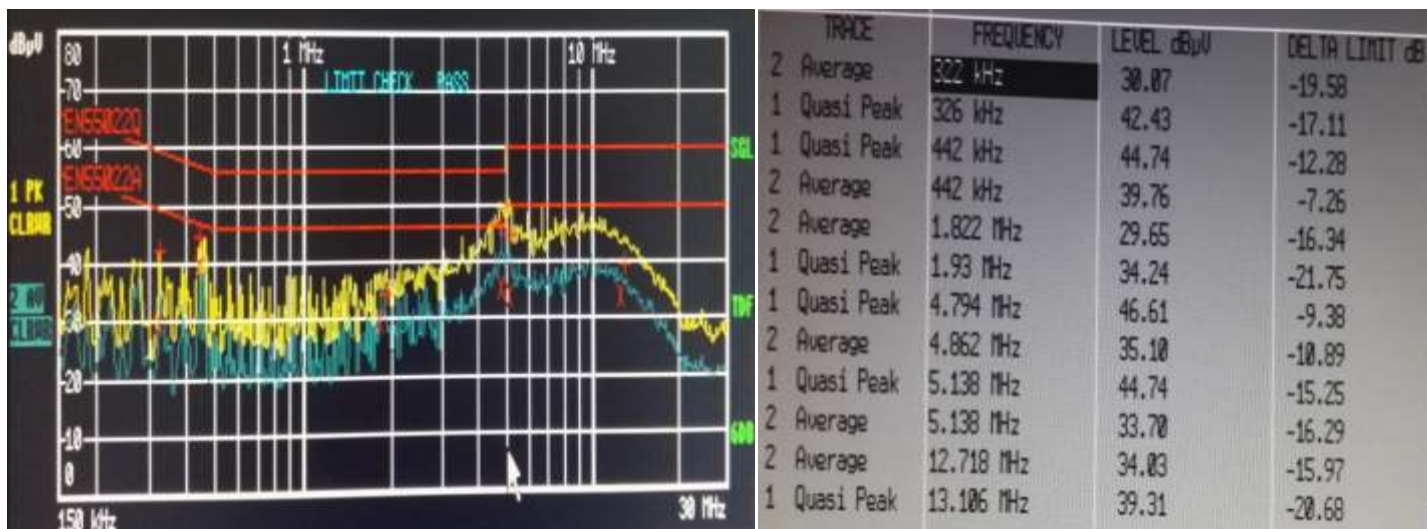

Figure 34: 230Vac/50Hz 12V/1.5A (L)

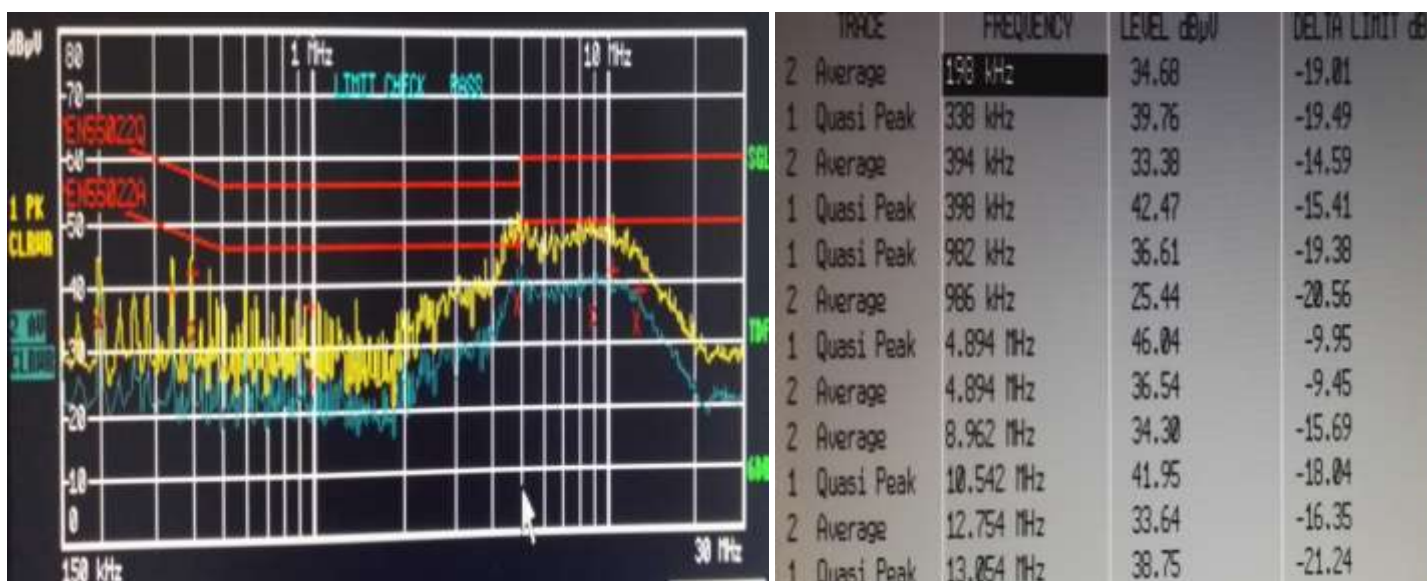

Figure 35: 230Vac/50Hz 12V/1.5A (N)

IMPORTANT NOTICE

DIODES INCORPORATED MAKES NO WARRANTY OF ANY KIND, EXPRESS OR IMPLIED, WITH REGARDS TO THIS DOCUMENT, INCLUDING, BUT NOT LIMITED TO, THE IMPLIED WARRANTIES OF MERCHANTABILITY AND FITNESS FOR A PARTICULAR PURPOSE (AND THEIR EQUIVALENTS UNDER THE LAWS OF ANY JURISDICTION).

Diodes Incorporated and its subsidiaries reserve the right to make modifications, enhancements, improvements, corrections or other changes without further notice to this document and any product described herein. Diodes Incorporated does not assume any liability arising out of the application or use of this document or any product described herein; neither does Diodes Incorporated convey any license under its patent or trademark rights, nor the rights of others. Any Customer or user of this document or products described herein in such applications shall assume all risks of such use and will agree to hold Diodes Incorporated and all the companies whose products are represented on Diodes Incorporated website, harmless against all damages.

Diodes Incorporated does not warrant or accept any liability whatsoever in respect of any products purchased through unauthorized sales channel. Should Customers purchase or use Diodes Incorporated products for any unintended or unauthorized application, Customers shall indemnify and hold Diodes Incorporated and its representatives harmless against all claims, damages, expenses, and attorney fees arising out of, directly or indirectly, any claim of personal injury or death associated with such unintended or unauthorized application.

Products described herein may be covered by one or more United States, international or foreign patents pending. Product names and markings noted herein may also be covered by one or more United States, international or foreign trademarks.

This document is written in English but may be translated into multiple languages for reference. Only the English version of this document is the final and determinative format released by Diodes Incorporated.

LIFE SUPPORT

Diodes Incorporated products are specifically not authorized for use as critical components in life support devices or systems without the express written approval of the Chief Executive Officer of Diodes Incorporated. As used herein:

- A. Life support devices or systems are devices or systems which:
1. are intended to implant into the body, or
 2. support or sustain life and whose failure to perform when properly used in accordance with instructions for use provided in the labeling can be reasonably expected to result in significant injury to the user.
- B. A critical component is any component in a life support device or system whose failure to perform can be reasonably expected to cause the failure of the life support device or to affect its safety or effectiveness.

Customers represent that they have all necessary expertise in the safety and regulatory ramifications of their life support devices or systems, and acknowledge and agree that they are solely responsible for all legal, regulatory and safety-related requirements concerning their products and any use of Diodes Incorporated products in such safety-critical, life support devices or systems, notwithstanding any devices- or systems-related information or support that may be provided by Diodes Incorporated. Further, Customers must fully indemnify Diodes Incorporated and its representatives against any damages arising out of the use of Diodes Incorporated products in such safety-critical, life support devices or systems.

Copyright © 2017, Diodes Incorporated

www.diodes.com