

**DRAPER**[®]

METAL, VOLTAGE & STUD DETECTOR

ENOriginal Instructions
Version 1**13818 - 501G** INSTRUCTIONS FOR USE

1. Preface

These are the original product instructions. This document is part of the product; retain it for the life of the product, passing it on to subsequent holders. Read this manual in full before attempting to assemble, operate, or maintain this product.

This Draper Tools manual describes the purpose of the product and contains all the necessary information to ensure its correct and safe use. Following all the instructions and guidance in this manual will ensure the safety of both the product and the operator and increase the lifespan of the product.

All photographs and drawings within this manual are supplied by Draper Tools to help illustrate correct operation of the product.

Every effort has been made to ensure the information contained in this manual is accurate. However, Draper Tools reserves the right to amend this document without prior warning. Always use the latest version of the product manual.

1.2 Revisions

Version 1: February 2018
First release

Version 2: June 2022
General content and formatting updates

Version 3: September 2023
Product specification update

As our manuals are continually updated, always ensure that the latest version is used.

Download the latest version from:
drapertools.com/manuals

1.3 Copyright © Notice

Copyright © Draper Tools Limited.

Permission is granted to reproduce this manual for personal and educational use **ONLY**. Commercial copying, redistribution, hiring, or lending is strictly prohibited.

No part of this manual may be stored in a retrieval system or transmitted in any other form or means without written permission from Draper Tools Limited.

In all cases, this copyright notice must remain intact.

1.4 Understanding the Safety Content

WARNING! – Situations or actions that may result in personal injury or death.

CAUTION! – Situations or actions that may result in damage to the product or surroundings.

Important: – Information or instructions of particular importance.

2. Warranty

Draper Tools products are carefully tested and inspected before shipment and are guaranteed to be free from defective materials and workmanship.

Should the tool develop a fault, return the complete tool to your nearest distributor or contact Draper Tools directly. Contact information can be found at the back of this manual.

Proof of purchase must be provided.

If, upon inspection, it is found that the fault occurring is due to defective materials or workmanship, repairs will be carried out free of charge. This warranty period covers parts and labour for 12 months from the date of purchase. Where tools have been hired out, the warranty period covers 90 days from the date of purchase.

This warranty does not apply to any consumable parts, batteries or normal wear and tear, nor does it cover any damage caused by misuse, careless or unsafe handling, alterations, accidents, or repairs attempted or made by any personnel other than the authorised Draper Tools repair agent.

In all cases, to make a claim for faulty workmanship or materials within the standard warranty period, please contact or return the product to the place of purchase. Proof of purchase may be required.

If the place of purchase is no longer trading or if you experience any difficulties with your warranty, please contact Customer Services with the product details and your proof of purchase. Contact details can be found at the back of this manual.

If the tool is not covered by the terms of this warranty, repairs and carriage charges will be quoted and charged accordingly.

This warranty supersedes any other guarantees expressed or implied and variations of its terms are not authorised.

Your Draper Tools guarantee is not effective until you can produce, upon request, a dated receipt or invoice to verify your purchase within the guarantee period.

Please note that this warranty is an additional benefit and does not affect your statutory rights.

Draper Tools Limited

3. Specification

Stock No.	13818
Part No.	501G
Maximum wood detecting depth	10mm
Maximum metal detecting depth	25mm
Maximum live wiring detecting depth	35mm
Ambient condition.	-20°C to 60°C below 80% RH
Battery	9V, PP3

4. Product Identification

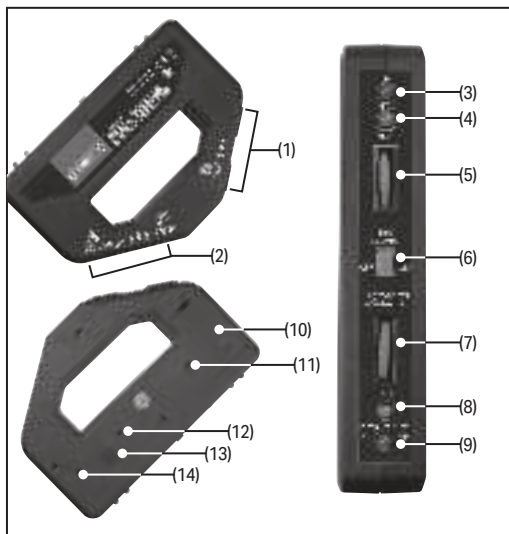

4.1 Product Overview

- (1) Stud detection face
- (2) Voltage/metal detection face
- (3) Stud indicator (red)
- (4) Stud indicator (green)
- (5) Stud sensitivity dial
- (6) Selector switch
- (7) Voltage/metal sensitivity dial

- (8) Power indicator (green)
- (9) Voltage/metal indicator (red)
- (10) Battery compartment cover
- (11) Stud detector trimmer
- (12) Voltage/metal detector trimmer
- (13) Buzzer
- (14) AC voltage detection adjuster (**Factory adjustment only; DO NOT tamper with this setting**)

5. Health and Safety Information

- Read this manual in full before using this product.
- This device is intended for use as a guide **ONLY**.
 - Lack of response from the detector does not guarantee the absence of metal, currents or wall studs.
 - Caution must still be exercised when working in walls and other blind surfaces.
- **DO NOT** immerse this device in water or allow the battery to come into contact with liquids.
- **DO NOT** abuse, mutilate or burn the battery.
- Check the device carefully before use.
 - **DO NOT** use this product if it is damaged in any way or there is evidence of battery leakage.

WARNING! This device emits a loud audible tone. Placing your ear over the buzzer openings may cause hearing damage.

6. Operation and Use

Install a 9V PP3 battery before use; see 7.2 Replacing the Battery.

6.1 AC Voltage and Metal Detection

1. Hold the unit and rotate the voltage/metal sensitivity dial (7) fully downwards.

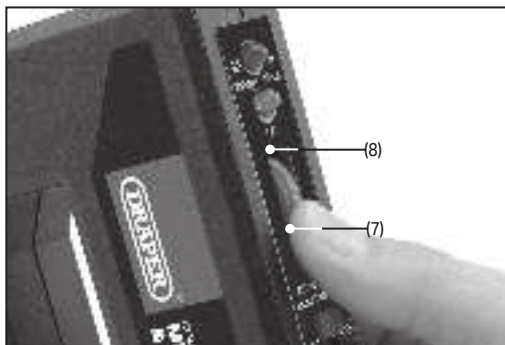

Fig. 1

2. Move the selector switch (6) to the **AC Voltage/Metal Detector** position; the power indicator (8) should illuminate.

Important: Ensure that the device is not positioned near any metal objects or current-carrying conductors when you switch it on.

3. Rotate the sensitivity dial (7) upwards until the metal/voltage indicator illuminates and the audible tone sounds, then reverse the dial gently until the indicators switch off.
4. Hold the device so that the voltage detection face (2) is flush with the wall and move it sideways across the surface.

5. The response of the indicators determines the object detected:

- **Constant LED and tone:** A metal object has been detected.
- **Intermittent LED and tone:** A current-carrying conductor has been detected.

Important: If the indicators do not function normally once the device is switched on, the device must be adjusted; see **6.4 Unit Adjustment**.

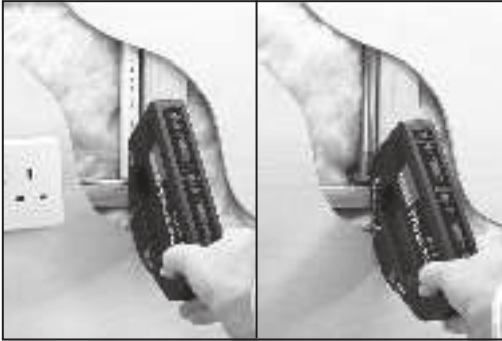

Fig. 2

Notes on Use

Important: ALWAYS test the device on a known voltage source before attempting to detect unfamiliar sources.

- This device cannot detect shielded current conductors, such as those in a metal conduit.
 - In this instance, only the presence of metal will be indicated.
- Some walls and surfaces may contain metallic fibres for fireproofing, such as foil-backed plasterboard, which may expand the area in which voltage is detected.
- Avoid touching the wall while it is being tested:
 - Sustained contact during the test may cancel out any detection by the device.
 - Rubbing or banging on the surface may generate static electricity and cause a false reading.

Important: The device is highly sensitive and may be triggered by very low currents, which may cause false readings to occur in some circumstances. For example, a conductor with poor insulation that is in contact with a damp wall may cause the device to indicate a voltage in the wall. When this occurs, the device is indicating a potential hazard that should be investigated by suitably qualified personnel before any additional work is carried out.

6.2 Wood Frame Detection

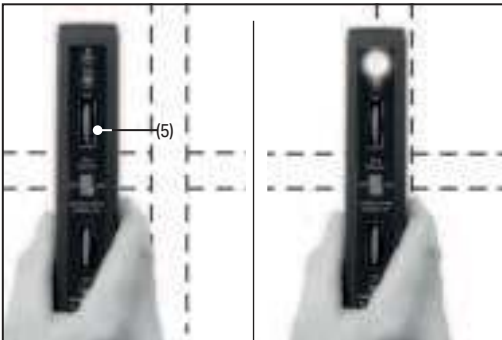

Fig. 3

To locate vertical battens or wall studs:

1. Hold the device so that the stud detection face (1) is flush with the wall.
2. Rotate the stud sensitivity dial (5) fully downwards.
3. Move the selector switch (6) to the **Stud Detector** position.
4. Turn the sensitivity dial until the red stud indicator (3) illuminates and the audible tone is heard.
5. Gently reverse the dial until the green stud indicator illuminates and the audible tone stops.

Important: If the indicators do not function normally once the device is switched on, the device must be adjusted; see **6.4 Unit Adjustment**.

6. Move the unit horizontally across the wall, ensuring that the stud detection face remains flush with the surface.
Important: If the device loses contact with the wall, the green indicator will go out and the procedure must be repeated from the beginning.
7. The red stud indicator will illuminate and the audible tone will start when the edge of a batten or wall stud is detected.
8. Resume the movement of the device and mark the position where the green stud indicator illuminates and the audible tone stops.

The marked positions indicate the edges of the batten or wall stud. The midpoint between the two marks represents the centre of the detected object.

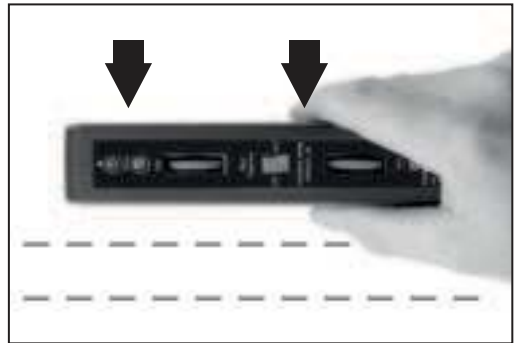

Fig. 4

Notes on Use

Important: While the device may be used to detect battens and wall studs within wallpapered walls, some foiled-backed or metallic fabric surfaces may cause incorrect readings.

- The device can be used to detect horizontal studs when held in a horizontal position and moved vertically along the wall face (Fig. 4).
- If the unit is placed against a stud or wall batten during configuration, readings may be inaccurate.
- Nails and other objects in a batten or wall stud may cause anomalous readings and change the apparent width of the detected object.
 - Take several readings along the length of a detected batten or wall stud to increase the reliability of the output.
- Draper Tools recommends recalibrating the device frequently during testing to increase the reliability of the output.
- Draper Tools recommends that metal/voltage detection is also carried out on any detected battens and wall studs to ensure that they are not pipes or cables.
Important: This process may detect small screws and nails. Consider all results in context.
- Where multiple studs are positioned adjacently, the device may appear to function incorrectly.

6.3 Maximizing Accuracy

The sensitivity of the unit can be pin-pointed to exactly identify the location place of pipes, cables, battens or studs.

1. Configure the device as normal (see 6.1 and 6.2 as appropriate) and sweep it across the surface so that the approximate location is detected.
2. Adjust the appropriate dial slightly downwards and perform the sweep again.
3. Repeat step 2 until the indicator and LED are no longer activated.
4. Adjust the dial slightly upwards and perform one final sweep to identify the exact location of the object.

6.4 Unit Adjustment

CAUTION! Any attempt to adjust the device must be made with the utmost care and only when absolutely necessary. Once it has been adjusted, it cannot be returned to the factory settings. DO NOT adjust the device unless you are confident in your actions; otherwise, contact Draper Tools for support.

The device is calibrated before shipment and should be ready for use. However, in the event that the device does not function as expected, it may require adjustment.



Fig. 5

AC Voltage and Metal Detection Adjustment:

1. Rotate the voltage/metal sensitivity dial (7) fully downwards, then rotate it upwards by a half turn.
2. Move the selector switch (6) to the "AC Voltage/Metal Detector" position.
3. Use the small screwdriver (15) to rotate the voltage/metal detector trimmer (12) as appropriate.

If **ONLY** the green power indicator (8) comes on:

- a. Slowly turn the trimmer **CLOCKWISE** and stop at the exact point at which the red voltage/metal indicator (9) and buzzer are activated.
- b. Slowly turn the trimmer **ANTICLOCKWISE** until the exact point at which the red indicator and buzzer stop.

If the green power indicator (8), the red voltage/metal indicator (9) and the buzzer, come on:

- a. Slowly turn the trimmer **ANTICLOCKWISE** until the exact point at which the red indicator and buzzer stop.

The device is now correctly adjusted.

Stud Detection Adjustment:

1. Rotate the stud sensitivity dial (5) fully downwards, then rotate it upwards by a half turn.
2. Move the selector switch (6) to the "Stud Detector" position.
3. Position the stud detection face (1) against the surface.
4. Use the small screwdriver (15) to rotate the stud detector trimmer (11) as appropriate.

If **ONLY** the green stud indicator (4) comes on:

- a. Slowly turn the trimmer **ANTICLOCKWISE** and stop at the exact point at which the red stud indicator (3) and buzzer are activated.
- b. Slowly turn the trimmer **CLOCKWISE** until the exact point at which the red indicator and buzzer stop.

If both the green (3) and red (4) stud indicators and the buzzer come on:

- a. Slowly turn the trimmer **ANTICLOCKWISE** until the exact point at which the red indicator and buzzer stop.

The device is now correctly adjusted.

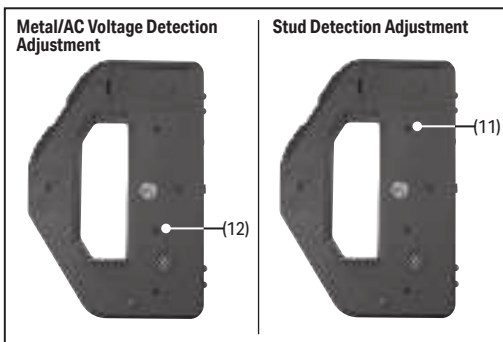

Fig. 6

Important: The adjustment mechanism is highly sensitive and only requires small amounts of rotation. If large adjustments are made, it may be very difficult to accurately recalibrate the unit. **Warranty claims will NOT be accepted if the device has been poorly adjusted by the user.**

A small screwdriver (15) is supplied for device adjustment and is located on the back of the battery compartment cover (10) (Fig. 5).

Maintenance and Disposal

7.1 Cleaning and Storage

- Clean the product regularly using a dry cloth.
CAUTION! NEVER use aggressive chemicals to clean the product as these may damage plastic or insulated parts.
- Remove the battery before storing the product for extended periods.
- Store the product in a clean and dry location, out of reach of children.

7.2 Replacing the Battery



Fig. 7

The detector is powered by a 9V PP3 type battery.

To connect or change a battery:

1. Unclip the battery compartment cover (10) on the back of the unit.
2. Remove the old battery from the compartment and disconnect it from the contacts.
3. Connect a new battery and insert it into the compartment.
4. Replace the compartment cover.

If the device is powered, the power indicator (8) will illuminate when the selector switch (6) is in the "AC Voltage/Metal Detector" position.

7.3 Disposal

At the end of its working life, or when it can no longer be repaired, dispose of this product according to local regulations.

Contact your local authority for details of collection schemes in your area.

In all circumstances:

- **DO NOT** dispose of this product with domestic waste.
- **DO NOT** incinerate.
- **DO NOT** abandon in the environment.
- Dispose of the battery in accordance with local regulations or return it to your warranty agent or stockist for recycling.
- **DO NOT** burn or mutilate batteries as this may release toxic or corrosive materials.

8. Explanation of Symbols



Read the instruction manual



Warning!



Do not abandon in the environment



Do not incinerate or throw onto fire



UK Conformity Assessed



European conformity

Contact Details

Draper Tools

Draper Tools Limited
Hursley Road
Chandler's Ford
Eastleigh
Hampshire
SO53 1YF
UK

Website: drapertools.com

Email: sales@drapertools.com

Product Helpline: +44 (0) 23 8049 4344

Telephone Sales Desk: +44 (0) 23 8049 4333

General Enquiries: +44 (0) 23 8026 6355

General Fax: +44 (0) 23 8026 0784

Delta International

Delta International BV
Oude Graaf 8
6002 NL
Weert
Netherlands

Service / Warranty Repair Agents

For aftersales servicing or warranty repairs, please contact the Draper Tools Product Helpline for details of an agent in your area.