

HORIZON[®]
H O B B Y

Eflite[®]
ADVANCING ELECTRIC FLIGHT

Extra 300 1.3m

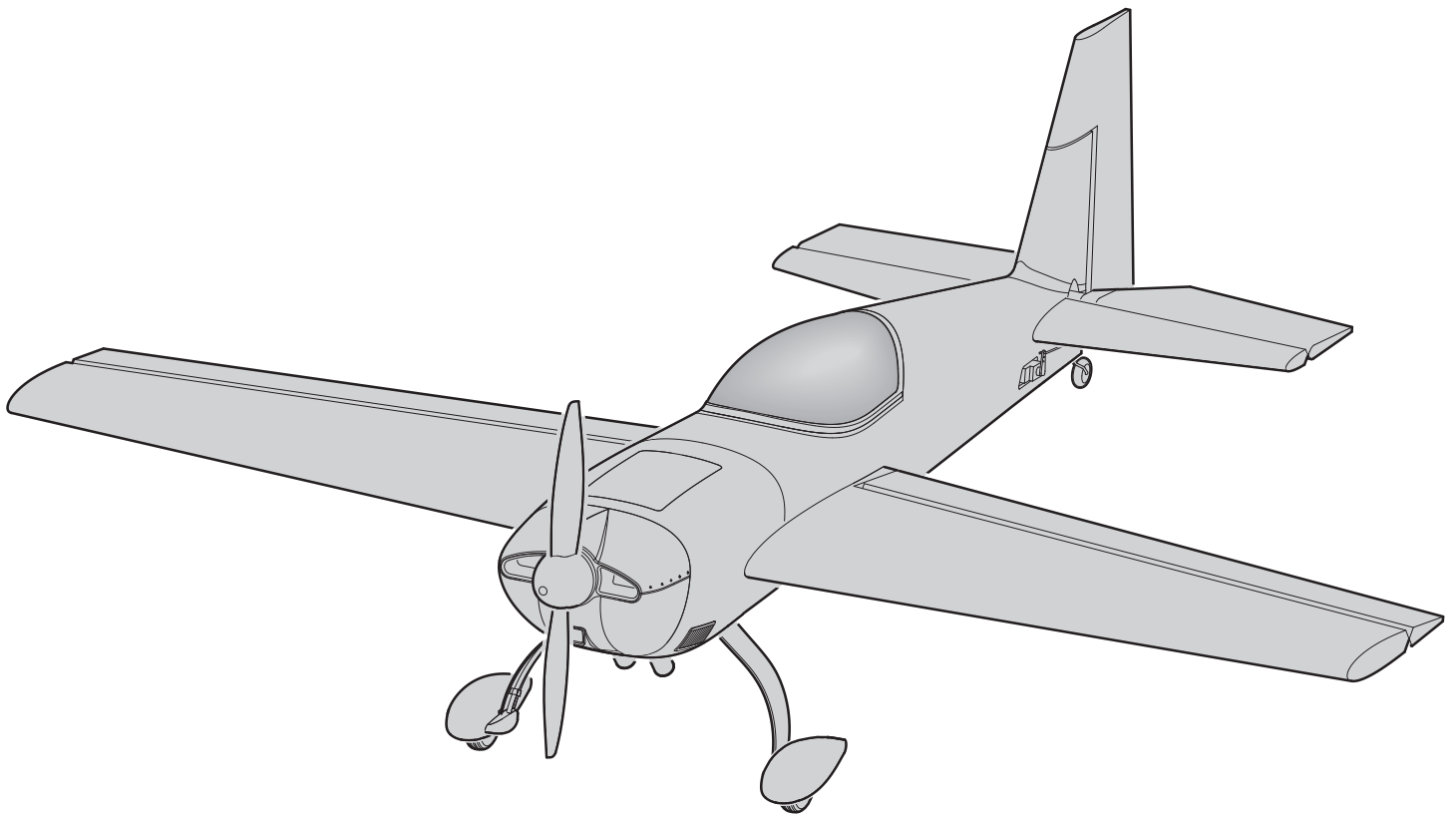

Instruction Manual
Bedienungsanleitung
Manuel d'utilisation
Manuale di Istruzioni

SAFE[®] 

SAFE[®] Select Technology, Optional Flight Envelope Protection

Bind-N-Fly[®] **Plug-N-Play**[®]
BASIC

NOTICE

All instructions, warranties and other collateral documents are subject to change at the sole discretion of Horizon Hobby, LLC. For up-to-date product literature, visit horizonhobby.com or towerhobbies.com and click on the support or resources tab for this product.

MEANING OF SPECIAL LANGUAGE

The following terms are used throughout the product literature to indicate various levels of potential harm when operating this product:

WARNING: Procedures, which if not properly followed, create the probability of property damage, collateral damage, and serious injury OR create a high probability of superficial injury.

CAUTION: Procedures, which if not properly followed, create the probability of physical property damage AND a possibility of serious injury.

NOTICE: Procedures, which if not properly followed, create a possibility of physical property damage AND little or no possibility of injury.



WARNING: Read the ENTIRE instruction manual to become familiar with the features of the product before operating. Failure to operate the product correctly can result in damage to the product, personal property and cause serious injury.

This is a sophisticated hobby product. It must be operated with caution and common sense and requires some basic mechanical ability. Failure to operate this Product in a safe and responsible manner could result in injury or damage to the product or other property. This product is not intended for use by children without direct adult supervision. Do not use with incompatible components or alter this product in any way outside of the instructions provided by Horizon Hobby, LLC. This manual contains instructions for safety, operation and maintenance. It is essential to read and follow all the instructions and warnings in the manual, prior to assembly, setup or use, in order to operate correctly and avoid damage or serious injury.

14+

AGE RECOMMENDATION:
Not for children under 14 years. This is not a toy.



WARNING AGAINST COUNTERFEIT PRODUCTS: If you ever need to replace your Spektrum receiver found in a Horizon Hobby product, always purchase from Horizon Hobby, LLC or a Horizon Hobby authorized dealer to ensure authentic high-quality Spektrum product. Horizon Hobby, LLC disclaims all support and warranty with regards, but not limited to, compatibility and performance of counterfeit products or products claiming compatibility with DSM or Spektrum technology.

Safety Precautions and Warnings

As the user of this product, you are solely responsible for operating in a manner that does not endanger yourself and others or result in damage to the product or the property of others.

- Always keep a safe distance in all directions around your model to avoid collisions or injury. This model is controlled by a radio signal subject to interference from many sources outside your control. Interference can cause momentary loss of control.
- Always operate your model in open spaces away from full-size vehicles, traffic and people.
- Always carefully follow the directions and warnings for this and any optional support equipment (chargers, rechargeable battery packs, etc.).
- Always keep all chemicals, small parts and anything electrical out of the reach of children.
- Always avoid water exposure to all equipment not specifically designed and protected for this purpose. Moisture causes damage to electronics.
- Never place any portion of the model in your mouth as it could cause serious injury or even death.
- Never operate your model with low transmitter batteries.
- Always keep aircraft in sight and under control.
- Always use fully charged batteries.
- Always keep transmitter powered on while aircraft is powered.
- Always remove batteries before disassembly.
- Always keep moving parts clean.
- Always keep parts dry.
- Always let parts cool after use before touching.
- Always remove batteries after use.
- Always ensure failsafe is properly set before flying.
- Never operate aircraft with damaged wiring.
- Never touch moving parts.

Box Contents

Quick Start Information			
Transmitter Setup	Set up your transmitter using the transmitter setup chart		
Travel and Dual Rates		Hi Rate 100%	Low Rate 70%
	Ail	50mm (2 in)	30mm (1.5 in)
	Ele	60mm (2.38 in)	45mm (1.75 in)
	Rud	100mm (4 in)	70mm (2.75 in)
Center of Gravity (CG)	3.5–4.0 in (90–100 mm) from leading edge of wing at the fuselage.		
Flight Timer Setting	3 minutes		

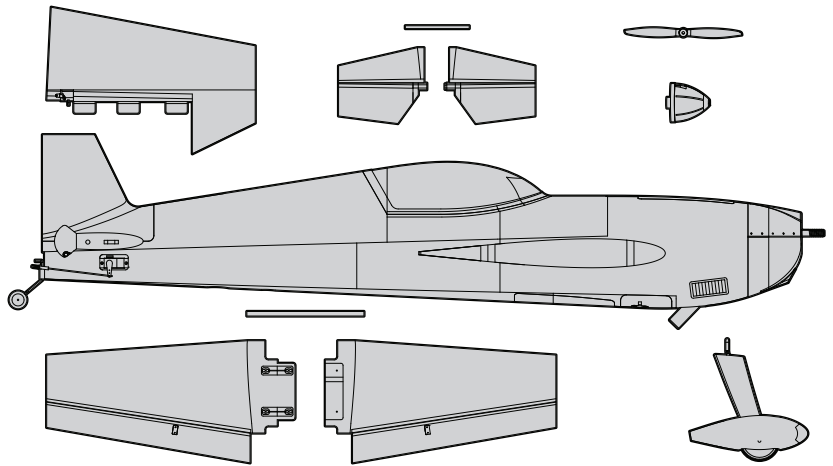

Components

		BNF BASIC	PNP PLUG-N-PLAY
	Motor: 4250-910Kv Motor (EFL11596)	Installed	Installed
	ESC: 60A ESC (EFL11597)	Installed	Installed
	Servo: 23 gram servo (EFL11598)	Installed	Installed
	Receiver: Spektrum™ AR631 6-Channel Receiver (SPMAR631)	Installed	Required to Complete
	Recommended Battery: 14.8V 4S 2200-3200mAh 30-40C Li-Po (SPMX22004S30, SPMX32004S30)	Required to Complete	Required to Complete
	Recommended Battery Charger: 4S LiPo Balancing Charger	Required to Complete	Required to Complete
	Recommended Transmitter: Full-Range 6 channel (or more) 2.4GHz with Spektrum DSM2®/DSMX® technology with adjustable Dual Rates	Required to Complete	Required to Complete

Table of Contents

Safety Precautions and Warnings	2
Box Contents	3
Components	3
Table of Contents	3
SAFE® Select Technology (BNF Basic)	4
Preflight	4
Transmitter Setup (BNF Basic)	4
Model Assembly	5
Transmitter and Receiver Binding / SAFE Select (BNF Basic)	8
Battery Installation and ESC Arming	9
SAFE® Select Switch Designation	10
Control Horn and Servo Arm Settings	10
Center of Gravity (CG)	11
AS3X Control Direction Test (BNF Basic)	11
In Flight Trimming (BNF Basic)	11
Flying Tips and Repairs	12
Post Flight	13
Motor Service	13
Troubleshooting Guide AS3X	13
Troubleshooting Guide	14
AMA National Model Aircraft Safety Code	15
Limited Warranty	16
Contact Information	17
FCC Information	17
IC Information	17
Compliance Information for the European Union	17
Replacement Parts	65
Optional Parts	66

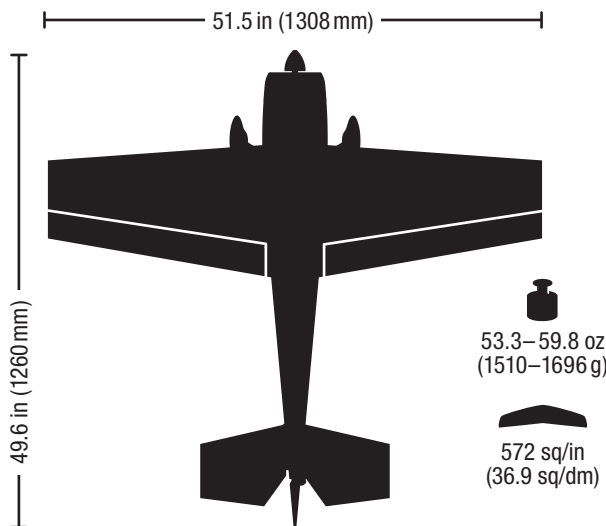

RECEIVER BIND INFORMATION	
Channels	6
Frequency	2404 – 2476 MHz
Compatibility	DSM2 and DSMX

If you own this product, you may be required to register with the FAA.

For up-to-date information on how to register with the FAA, visit <https://registermyuas.faa.gov/>.

For additional assistance on regulations and guidance on UAS usage, visit knowbeforeyoufly.org/.

To receive product updates, special offers and more, register your product at www.horizonhobby.com.

SAFE® Select Technology (BNF Basic)

The evolutionary SAFE® Select technology can offer an extra level of protection so you can perform the first flight with confidence. No complex transmitter programming is required. Just follow the simple bind process to make the SAFE Select system active. When activated, bank and pitch limitations keep you from over-controlling and automatic self-leveling makes recovery from risky or confusing attitudes as simple as releasing the sticks. In fact, with the aileron, elevator and rudder sticks in the neutral position, SAFE Select will automatically keep the airplane in a straight and level attitude.

Expand the advantage of what SAFE® Select technology offers by assigning it to a switch. No transmitter programming is required and you'll be able to turn the system ON and OFF with the flip of a switch. For example, turn SAFE select ON for takeoffs to counter the torque of the propeller. Turn it OFF in flight for unrestricted aerobatic performance, and turn it back ON when a buddy wants to try out your cool aircraft. Turn SAFE Select ON for landings. As you drop the flaps, SAFE Select reduces your workload by compensating for pitch changes automatically, regardless of throttle position. It will help keep the correct pitch attitude and wings level during the final approach. Whether you're a beginner or an expert, SAFE Select can make your flights a great experience.

When the normal bind process is followed, the SAFE Select system is disabled, leaving specially tuned AS3X® technology in place to deliver a pure, unrestricted flight experience.

Preflight

1. Remove and inspect contents.	9. Make sure linkages move freely.
2. Read this instruction manual thoroughly.	10. Test the flap operation.
3. Charge the flight battery.	11. Perform the Control Direction Test with the transmitter.
4. Setup Transmitter using transmitter setup chart.	12. Perform the AS3X Control Direction Test with the aircraft.
5. Fully assemble the airplane.	13. Adjust flight controls and transmitter.
6. Install the flight battery in the aircraft (once it has been fully charged).	14. Perform a radio system Range Test.
7. Check the Center of Gravity (CG).	15. Find a safe open area to fly.
8. Bind the aircraft to your transmitter.	16. Plan flight for flying field conditions.

Transmitter Setup (BNF Basic)

IMPORTANT: After you set up your model, always rebind the transmitter and receiver to set the desired failsafe positions.

Dual Rates

Take first flights in Low Rate. For landings, use high rate elevator.

NOTICE: To ensure AS3X® technology functions properly, do not lower rate values below 50%. If lower rates are desired, manually adjust the position of the pushrods on the servo arm.

NOTICE: If oscillation occurs at high speed, refer to the Troubleshooting Guide for more information.

Expo

If your radio is equipped with Exponential, the values listed in the chart below are a good starting point. After first flights, you may adjust expo in your transmitter.

	Exponential (Low) Rates	Exponential (High) Rates
Aileron	15%	30%
Elevator	15%	30%
Rudder	15%	30%

Model Assembly

Landing Gear Installation

1. Fit the landing gear into the slot.
2. Install the landing gear cover and secure using four 3 x 15 mm screws.

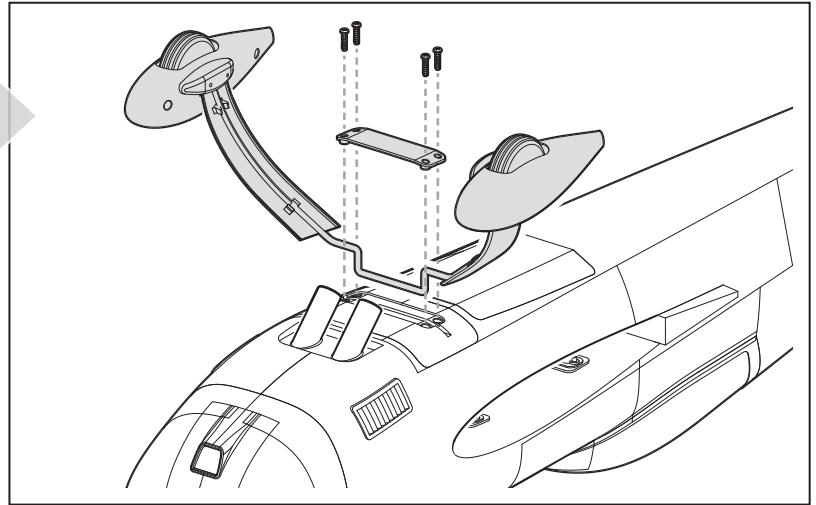

Tail Installation

Horizontal Stabilizer

1. Insert the horizontal stabilizer tube into one of the stab halves.
2. Slide the halves together into the fuselage. Key the mating elevator parts together snugly.
3. Install two 3 x 15 mm screws to secure the stab halves.
4. Insert the Z-Bend of the pushrod into the outside hole of the elevator servo arm and press the elevator pushrod end onto the elevator control horn ball.

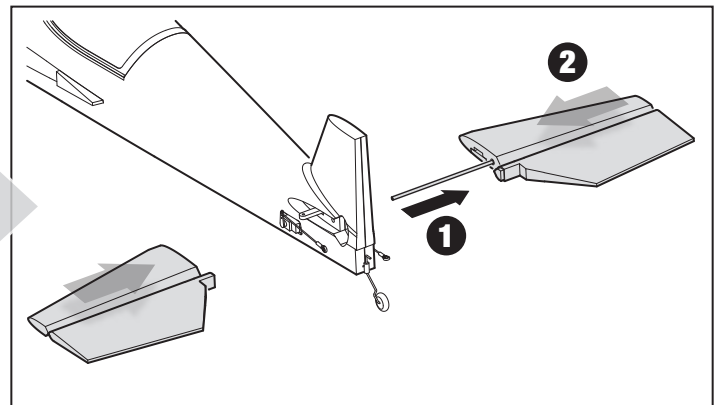

Vertical Fin

5. Apply epoxy or medium/thick CA glue to the rudder hinge tabs. Slide the hinges into the hinge slot while guiding the tail wheel wire into the bracket. **IMPORTANT:** Do not get glue near the hinge pins. Allow the glue to fully set before continuing.
6. Install the 2 x 8 mm flat head screws into the tail wire bracket on the rudder.
7. Insert the Z-Bend into the outside hole of the rudder servo arm and press the rudder pushrod end onto the rudder control horn ball.

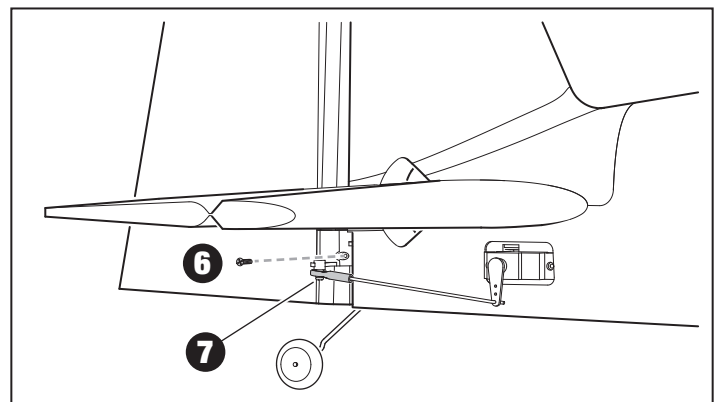
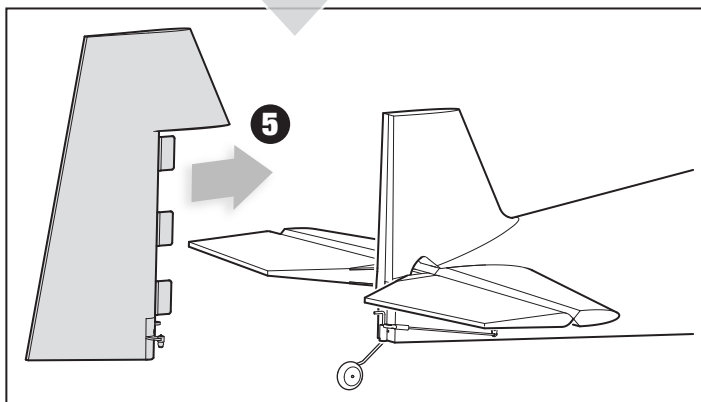
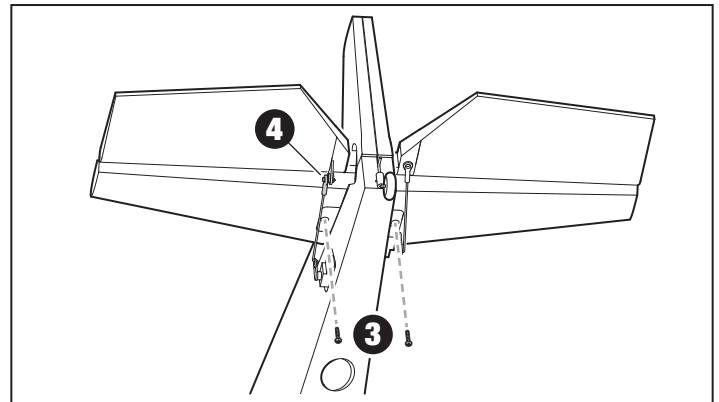

Model Assembly *Continued*

Wing Installation

1. Remove the magnetic bottom hatch cover.
2. Slide the wing joiner into one of the wing panels. Insert that panel into the wing opening in the fuselage and install the other wing panel onto the wing joiner. Make sure the aileron servo leads from each wing are routed inside the wing saddle and out the bottom hatch.

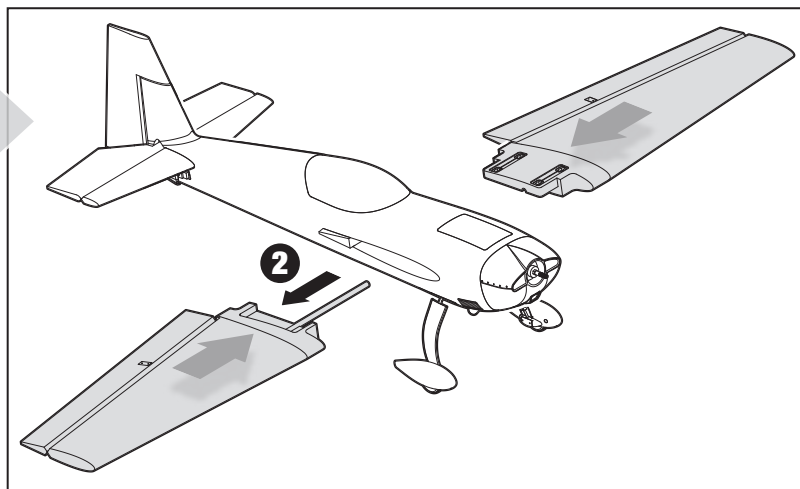

3. Secure the wing panels to the fuselage using four 3 x 30 mm screws.

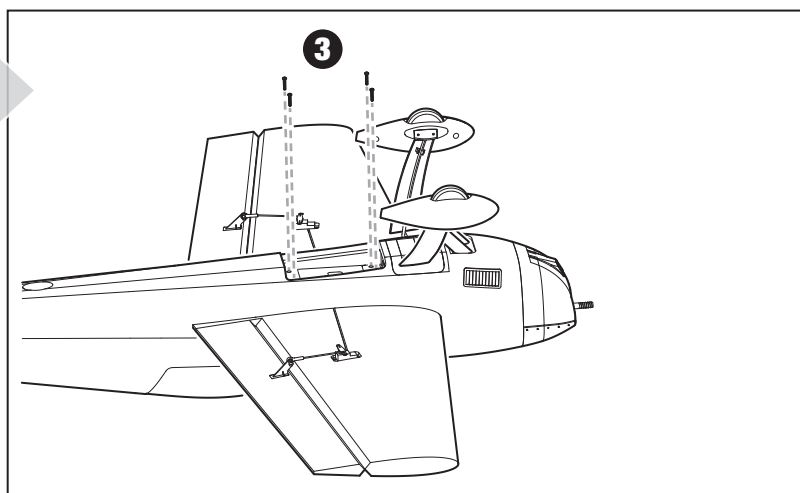

Propeller Installation

1. Install the spinner back plate, propeller, prop washer, and prop nut.
2. Tighten the prop nut until the propeller is installed on the motor shaft securely.
3. Secure the spinner with the 3 x 15 mm screw.

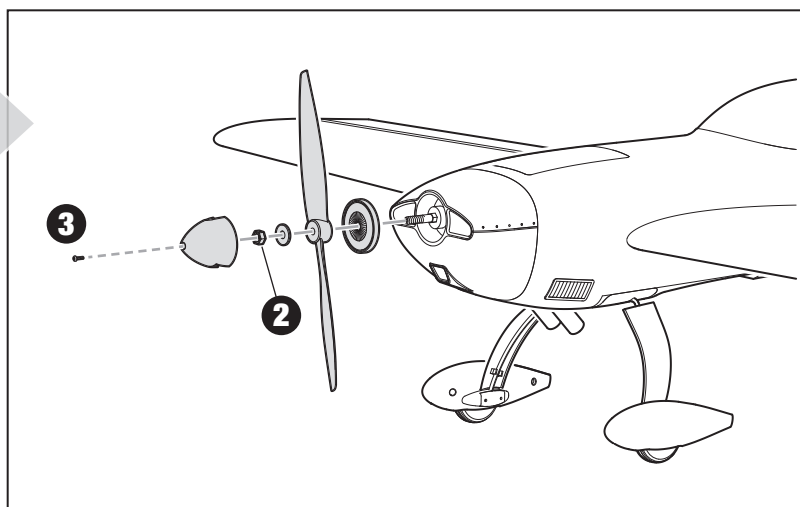

Model Assembly *Continued*

PNP Receiver Selection and Installation

The Spektrum™ AR631 receiver is recommended for this airplane.

If you choose to install another receiver, ensure that it is at least a 4-channel full range receiver. Refer to your receiver manual for correct installation and operation instructions.

Installation (AR631 shown)

1. Remove the magnetic bottom hatch cover.
2. Mount the receiver parallel to the length of the fuselage as shown. Use a small piece from the included hook and loop material.

NOTICE: Incorrect installation of the receiver could cause a crash.

3. Attach the appropriate ESC and servo leads to their respective ports on the receiver using the chart in the illustration.
4. Use the included Y-Harness to connect the two aileron servos.

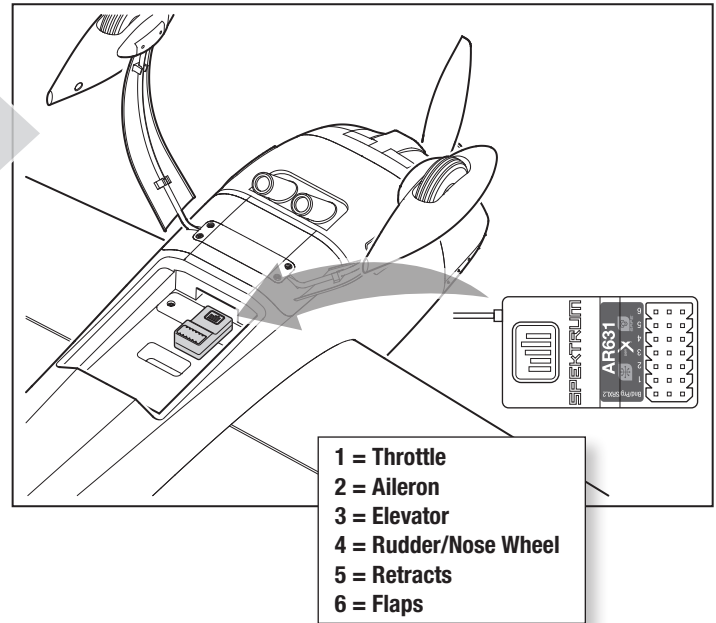

Control Surface Centering

After assembly and transmitter setup, bind a transmitter to the aircraft receiver and set the trims and sub-trims to 0.

If the control surfaces are not centered, adjust the linkages by turning the pushrod end on the linkage to change its length.

- Turn the pushrod end clockwise or counterclockwise until the control surface is centered.
- Attach the linkage to the servo arm or control horn after adjustment.

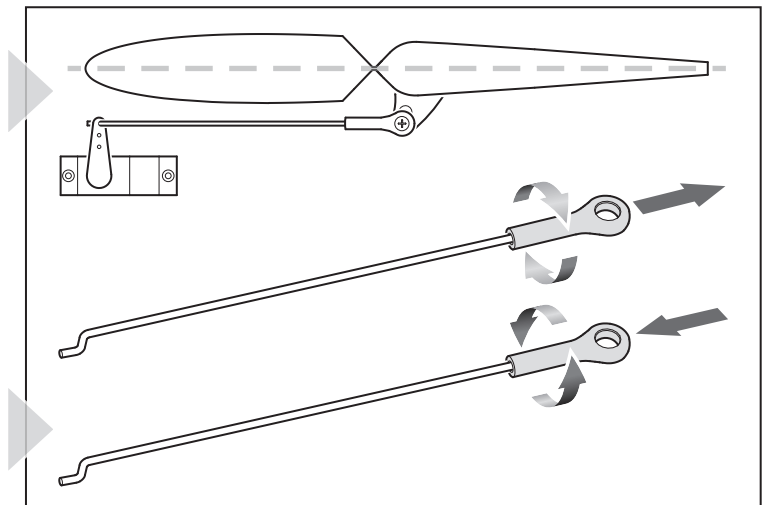

Transmitter and Receiver Binding / Enabling and Disabling SAFE Select (BNF Basic)

This product requires an approved Spektrum™ DSM2®/DSMX® compatible transmitter. Visit www.bindnfly.com for a complete list of approved transmitters.

The aircraft has an optional SAFE Select feature, which can be switched ON or OFF easily by binding in a specific manner as described below.

IMPORTANT: Before binding a transmitter, read the Transmitter Setup section of this manual to ensure that your transmitter is properly programmed for this aircraft.

Bind Plug Installation

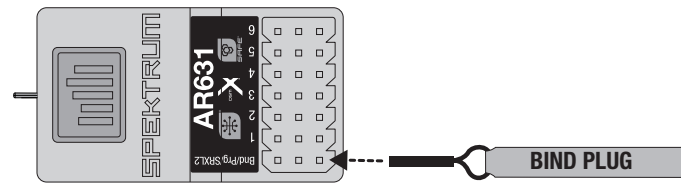

Binding Procedure / Switching ON SAFE Select

IMPORTANT: The included AR631 receiver has been programmed for operation specifically for this aircraft. Refer to the receiver manual for correct setup if the receiver is replaced or is used in another aircraft.

CAUTION: When using a Futaba® transmitter with a Spektrum DSM® module, you must reverse the throttle channel and rebind. Refer to your Spektrum module manual for binding and failsafe instructions. Refer to your Futaba transmitter manual for instructions on reversing the throttle channel.

1. Make sure the transmitter is powered off.
2. Move the transmitter controls to neutral (flight controls: rudder, elevators and ailerons) or to low positions (throttle, throttle trim).*
3. Install a bind plug in the receiver bind port.
4. Place the aircraft level on its wheels, then connect the flight battery to the ESC. The ESC will produce a series of sounds. Three flat tones followed immediately by two ascending tones confirm that the LVC is set correctly for the ESC. The orange bind LED on the receiver will begin to flash rapidly.
5. Remove the bind plug from the bind port.
6. Take three steps away from the aircraft /receiver and then power ON the transmitter while holding the transmitter bind button or switch. Refer to your transmitter's manual for specific binding instructions.
IMPORTANT: Do not point the transmitter's antenna directly at the receiver while binding.
IMPORTANT: Keep away from large metal objects while binding.
7. The receiver is bound to the transmitter when the orange bind light on the receiver stays orange. The ESC will produce a series of sounds. Three or four flat tones followed immediately by two ascending tones. The tones indicate the number of cells in the battery and that the ESC is armed, provided the throttle stick and throttle trim are low enough to trigger arming.

IMPORTANT: Once bound, the receiver will retain its bind settings for that transmitter until it has been intentionally changed, even when power is cycled ON and OFF. Repeat the binding process as necessary.

SAFE Select ON Indication

Every time the receiver is powered ON the surfaces will cycle back and forth **twice** with a slight pause at neutral position to indicate that SAFE Select is switched ON.

The throttle will not arm if the transmitter's throttle control is not put at the lowest position. If problems are encountered, follow the binding instructions and refer to the transmitter troubleshooting guide for other instructions. If needed, contact the appropriate Horizon Product Support office.

*Failsafe

If the receiver loses transmitter communication, the failsafe will activate. When activated, failsafe moves the throttle channel to its preset failsafe position (low throttle) that was set during binding. All other channels move to actively level the aircraft in flight.

Switching ON SAFE Select Binding Sequence

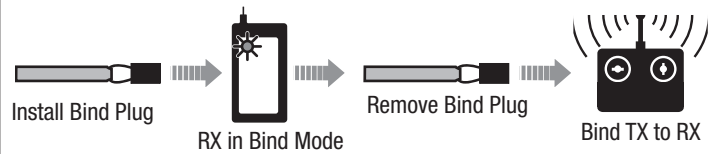

Switching OFF SAFE Select Binding Sequence

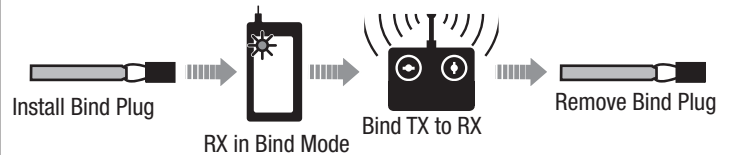

Binding Procedure / Switching OFF SAFE Select

IMPORTANT: The included AR631 receiver has been programmed for operation specifically for this aircraft. Refer to the receiver manual for correct setup if the receiver is replaced or is used in another aircraft.

CAUTION: When using a Futaba® transmitter with a Spektrum DSM® module, you must reverse the throttle channel and rebind. Refer to your Spektrum module manual for binding and failsafe instructions. Refer to your Futaba transmitter manual for instructions on reversing the throttle channel.

1. Make sure the transmitter is powered off.
2. Move the transmitter controls to neutral (flight controls: rudder, elevators and ailerons) or to low positions (throttle, throttle trim).*
3. Install a bind plug in the receiver bind port.
4. Place the aircraft level on its wheels, then connect the flight battery to the ESC. The ESC will produce a series of sounds. Three flat tones followed immediately by two ascending tones confirm that the LVC is set correctly for the ESC. The orange bind LED on the receiver will begin to flash rapidly. **DO NOT remove the bind plug at this time.**
5. Take three steps away from the aircraft /receiver and then power ON the transmitter while holding the transmitter bind button or switch. Refer to your transmitter's manual for specific binding instructions.
IMPORTANT: Do not point the transmitter's antenna directly at the receiver while binding.
IMPORTANT: Keep away from large metal objects while binding.
6. The receiver is bound to the transmitter when the orange bind light on the receiver stays orange. The ESC will produce a series of sounds. Three or four flat tones followed immediately by two ascending tones. The tones indicate the number of cells in the battery and that the ESC is armed, provided the throttle stick and throttle trim are low enough to trigger arming.

7. Remove the bind plug from the bind port.

IMPORTANT: Once bound, the receiver will retain its bind settings for that transmitter until it has been intentionally changed, even when power is cycled ON and OFF. Repeat the binding process as necessary.

SAFE Select OFF Indication

Every time the receiver is powered ON the surfaces will cycle back and forth **once** to indicate that SAFE Select has been switched OFF.

The throttle will not arm if the transmitter's throttle control is not put at the lowest position. If problems are encountered, follow the binding instructions and refer to the transmitter troubleshooting guide for other instructions. If needed, contact the appropriate Horizon Product Support office.

Battery Installation and ESC Arming

Battery Selection

The Spektrum™ 2200 mAh 14.8V 4S 30C Li-Po battery (SPMX22004S30) is recommended. Refer to the Optional Parts List for other recommended batteries. If using a battery other than those listed, the battery should be within the range of capacity, dimensions and weight of the Spektrum Li-Po battery packs to fit in the fuselage. Be sure the model balances at the recommended CG before flying.

1. Lower the throttle and throttle trim to the lowest settings. Power on the Transmitter, then wait 5 seconds.
2. Lift the hatch by the tab, to remove.
3. Apply the loop side (soft side) of the hook and loop tape to the bottom of your battery and the hook side to the battery tray.
4. Install the fully charged battery in the middle of the battery compartment, as shown. Secure using the hook and loop straps.
5. Connect the battery to the ESC (the ESC is now armed).
6. Keep the aircraft immobile and away from wind, upright and on flat surface or the system will not initialize.
 - The ESC will produce a series of sounds. A single tone followed immediately by three or four tones, which indicates cell count.
 - An LED will light on the receiver.
7. Reinstall the battery hatch.



CAUTION: Always keep hands away from the propeller. When armed, the motor will turn the propeller in response to any throttle movement.

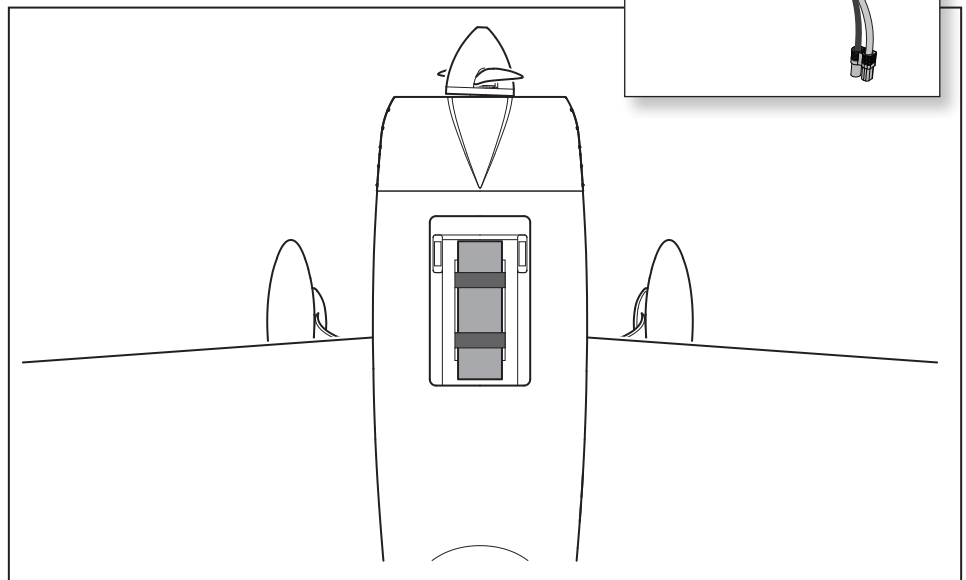
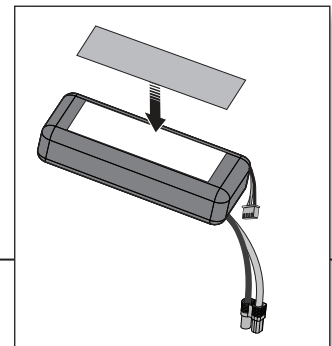
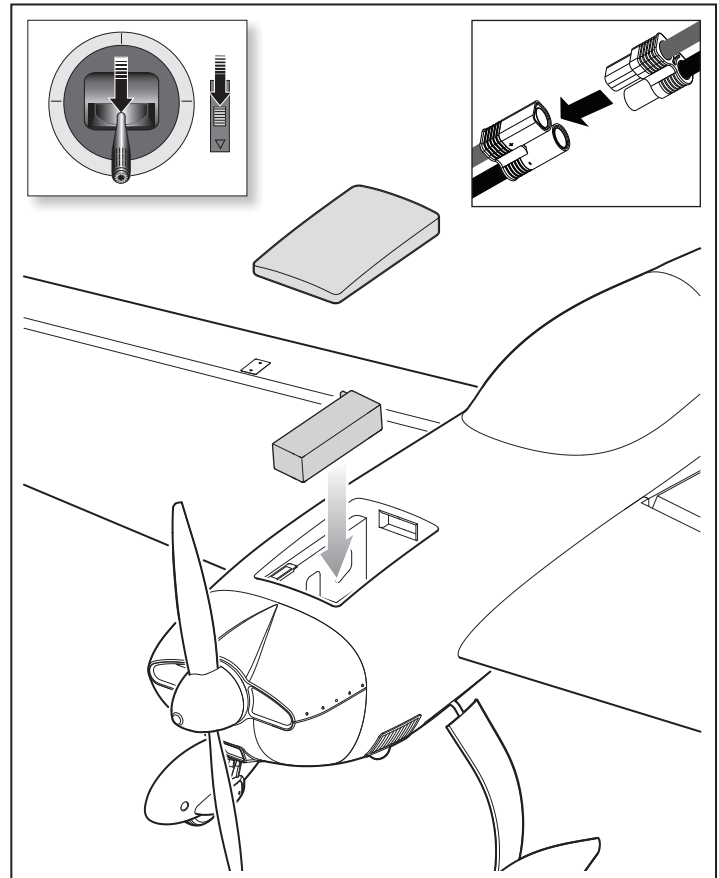

SAFE® Select Switch Designation

SAFE® Select technology can be easily assigned to any open switch (two or three position) on the transmitter. With this new feature, you now have the flexibility to switch SAFE On and Off while in flight.

IMPORTANT: Before assigning your desired switch, ensure that the travel for that channel is set at 100% in both direction.

Assigning a switch

1. Bind the aircraft correctly to activate SAFE Select. This will allow the system to be assigned to a switch.
2. Hold both transmitter sticks to the inside bottom corners and toggle the desired switch five times (one toggle = full up and down) to assign that switch. The control surfaces of the aircraft will move, indicating the switch has been selected.

Repeat the process to assign a different switch if desired.

TIP: SAFE Select is assignable on any unused Channels 5–9

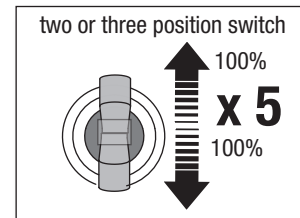
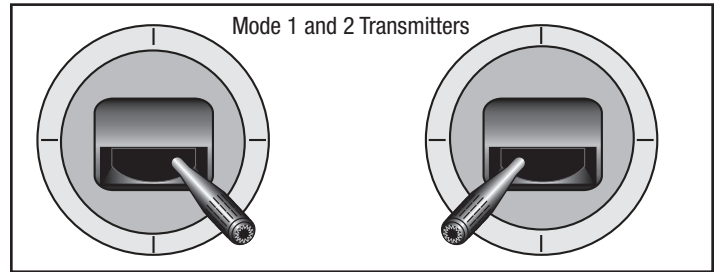

Control Horn and Servo Arm Settings

The table to the right shows the factory settings for the control horns and servo arms. Fly the aircraft at factory settings before making changes.

NOTICE: If control throws are changed from the factory settings, the AR631 gain values may need to be adjusted. Refer to the Spektrum AR631 manual for adjustment of gain values.

After flying, you may choose to adjust the linkage positions for the desired control response. See the table to the right.

Factory Setting	Control Horns	Servo Arms
Elevator		
Rudder		
Aileron		

Tuning	Horns	Arms
More control throw		
Less control throw		

Center of Gravity (CG)

The CG location is measured from the leading edge of the wing at the root. This CG location has been determined with the recommended Li-Po battery (SPMX22004S30).

Tip: Measure the CG with the aircraft inverted.

NOTICE: Install the battery but do not connect the ESC while checking the CG. Personal injury may result.

90–100 mm +/- 3mm
back from leading edge
of wing at the fuselage.

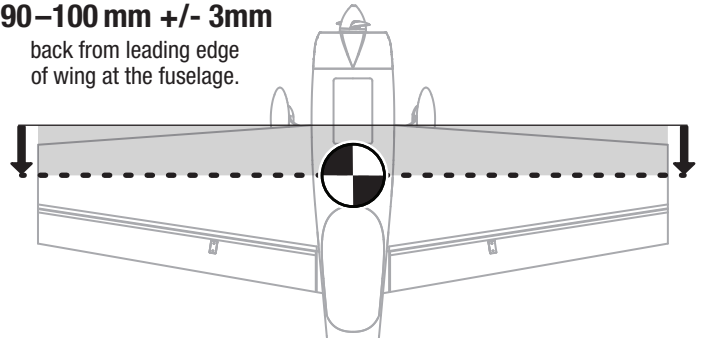

AS3X Control Direction Test (BNF Basic)

This test ensures that the AS3X® control system is functioning properly. Assemble the aircraft and bind your transmitter to the receiver before performing this test.

1. Raise the throttle just above 25%, then lower the throttle to activate AS3X technology.



CAUTION: Keep all body parts, hair and loose clothing away from a moving propeller, as these items could become entangled.

2. Move the entire aircraft as shown and ensure the control surfaces move in the direction indicated in the graphic. If the control surfaces do not respond as shown, do not fly the aircraft. Refer to the receiver manual for more information.

Once the AS3X system is active, control surfaces may move rapidly. This is normal. AS3X remains active until the battery is disconnected.

	Aircraft movement	AS3X Reaction
Elevator		
Aileron		
Rudder		

In Flight Trimming (BNF Basic)

During your first flight, trim the aircraft for level flight at 3/4 throttle. Make small trim adjustments with your transmitter's trim switches to straighten the aircraft's flight path.

After adjusting the trim, do not touch the control sticks for 3 seconds. This allows the receiver to learn the correct settings to optimize AS3X performance.

Failure to do so could affect flight performance.

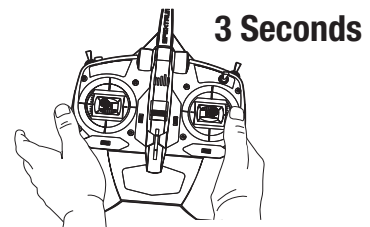

Flying Tips and Repairs

Consult local laws and ordinances before choosing a flying location.

Range Check your Radio System

Before you fly, range check the radio system. Refer to your specific transmitter instruction manual for range test information.

Oscillation

Once the AS3X system is active (after advancing the throttle for the first time), you will normally see the control surfaces react to aircraft movement. In some flight conditions you may see oscillation (the aircraft rocks back and forth on one axis due to overcontrol). If oscillation occurs, refer to the Troubleshooting Guide for more information.

Takeoff

Remember to take off into the wind. When you're ready, set your rudder control rates to high and point the model straight down the runway, hold a bit of up elevator to keep the tail on the ground to maintain tail wheel steering, then gradually advance the throttle. As the model gains speed, decrease up elevator allowing the tail to come off the ground. One of the most important things to remember with a tail dragger is to always be ready to apply right rudder to counteract engine torque. Gain as much speed as your runway and flying site will practically allow before gently applying up elevator, lifting the model into the air.

Flying

For your first flights with the recommended battery pack (SPMX22004S30), set your transmitter timer or a stopwatch to 3 minutes. After 3 minutes, land the aircraft. Adjust your timer for longer or shorter flights once you have flown the model. If at any time the motor power reduces, land the aircraft immediately to recharge the flight battery. See the Low Voltage Cutoff (LVC) section for more details on maximizing battery health and run time.

Landing

To initiate a landing approach, lower the throttle while on the downwind leg. Continue to lose altitude, but maintain airspeed by keeping the nose down as you turn onto the crosswind leg. Make your final turn toward the runway (into the wind) keeping the nose down to maintain airspeed and control. Level the attitude when the model reaches the runway threshold, modulating the throttle as necessary to maintain your glide path and airspeed. If you are going to overshoot, smoothly advance the throttle (always ready on the right rudder to counteract torque). Climb out to make another attempt. When the model is a foot or so off the runway, smoothly increase up elevator until it gently touches down. Once the model is on the runway and has lost flying speed, hold up elevator to place the tail on the ground, regaining tail wheel control.

NOTICE: If a crash is imminent, reduce the throttle and trim fully. Failure to do so could result in extra damage to the airframe, as well as damage to the ESC and motor.

NOTICE: After any impact, always ensure the receiver is secure in the fuselage. If you replace the receiver, install the new receiver in the same orientation as the original receiver or damage may result.

NOTICE: Crash damage is not covered under warranty.

NOTICE: When you are finished flying, never leave the aircraft in direct sunlight or in a hot, enclosed area such as a car. Doing so can damage the aircraft.

NOTICE: Always decrease throttle at propeller strike.

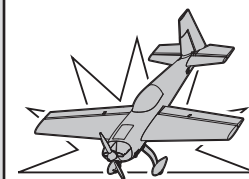

Low Voltage Cutoff (LVC)

When a Li-Po battery is discharged below 3V per cell, it will not hold a charge. The ESC protects the flight battery from over-discharge using Low Voltage Cutoff (LVC). Before the battery charge decreases too much, LVC removes power supplied to the motor. Power to the motor reduces, showing that some battery power is reserved for flight control and safe landing.

Disconnect and remove the Li-Po battery from the aircraft after use to prevent trickle discharge. Charge your Li-Po battery to about half capacity before storage. During storage, make sure the battery charge does not fall below 3V per cell. LVC does not prevent the battery from over-discharge during storage.

NOTICE: Repeated flying to LVC will damage the battery.

Tip: Monitor your aircraft battery's voltage before and after flying by using a Li-Po Cell Voltage Checker (SPMXBC100, sold separately).

Repairs

Thanks to the EPO foam material in this aircraft, repairs to the foam can be made using virtually any adhesive (hot glue, regular CA, epoxy, etc). When parts are not repairable, see the Replacement Parts List for ordering by item number. For a listing of all replacement and optional parts, refer to the list at the end of this manual.

NOTICE: Use of CA accelerant on your aircraft can damage paint. DO NOT handle the aircraft until accelerant fully dries.

Post Flight

- | | |
|---|---|
| 1. Disconnect the flight battery from the ESC (Required for Safety and battery life). | 5. Repair or replace all damaged parts. |
| 2. Power OFF the transmitter. | 6. Store the flight battery apart from the aircraft and monitor the battery charge. |
| 3. Remove the flight battery from the aircraft. | 7. Make note of the flight conditions and flight plan results, planning for future flights. |
| 4. Recharge the flight battery. | |

Motor Service



CAUTION: Always disconnect the flight battery before performing motor service.

Disassembly

1. Remove the spinner screw and spinner.
2. Use a tool to remove the propeller nut and then the prop washer and prop.
3. Pull off the magnetically held cowl.
4. Remove the four 3 x 15mm self tapping screws and the motor with the X-mount from the fuselage.
5. Disconnect the motor wires from the ESC wires.

Assembly

1. Assemble in reverse order.
 - Correctly align and connect the motor wire colors with the ESC wires.
 - Install the propeller with the numbers facing out from the motor.
 - Tighten the spinner screw to secure the propeller into place.

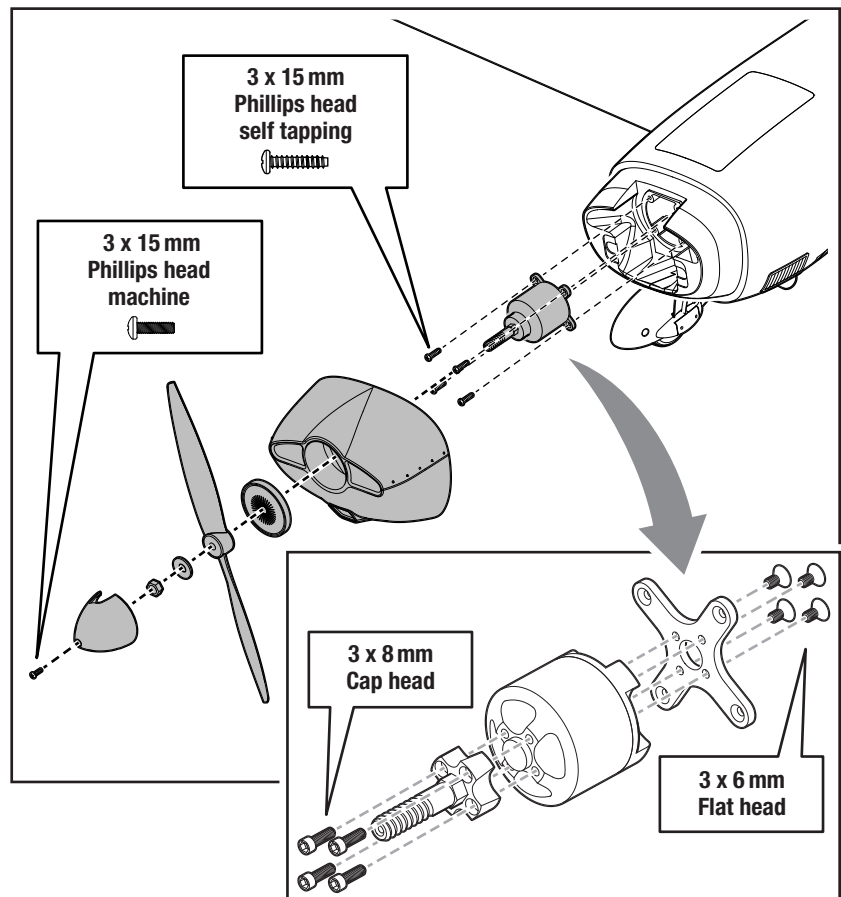

Troubleshooting Guide AS3X

Problem	Possible Cause	Solution
Oscillation	Damaged propeller or spinner	Replace propeller or spinner
	Imbalanced propeller	Balance the propeller
	Motor vibration	Replace parts or correctly align all parts and tighten fasteners as needed
	Loose receiver	Align and secure receiver in fuselage
	Loose aircraft controls	Tighten or otherwise secure parts (servo, arm, linkage, horn and control surface)
	Worn parts	Replace worn parts (especially propeller, spinner or servo)
	Irregular servo movement	Replace servo
Inconsistent flight performance	Trim is not at neutral	If you adjust trim more than 8 clicks, adjust the clevis to remove trim
	Sub-Trim is not at neutral	No Sub-Trim is allowed. Adjust the servo linkage
	Aircraft was not kept immobile for 5 seconds after battery connection	With the throttle stick in lowest position. Disconnect battery, then reconnect battery and keep the aircraft still for 5 seconds
Incorrect response to the AS3X Control Direction Test	Incorrect direction settings in the receiver, which can cause a crash	DO NOT fly. Correct the direction settings (refer to the receiver manual), then fly

Troubleshooting Guide

Problem	Possible Cause	Solution
Aircraft will not respond to throttle but responds to other controls	Throttle not at idle and/or throttle trim too high	Reset controls with throttle stick and throttle trim at lowest setting
	Throttle servo travel is lower than 100%	Make sure throttle servo travel is 100% or greater
	Throttle channel is reversed	Reverse throttle channel on transmitter
	Motor disconnected from ESC	Make sure motor is connected to the ESC
Extra propeller noise or extra vibration	Damaged propeller and spinner, collet or motor	Replace damaged parts
	Propeller is out of balance	Balance or replace propeller
	Prop nut is too loose	Tighten the prop nut
Reduced flight time or aircraft underpowered	Flight battery charge is low	Completely recharge flight battery
	Propeller installed backwards	Install propeller with numbers facing forward
	Flight battery damaged	Replace flight battery and follow flight battery instructions
	Flight conditions may be too cold	Make sure battery is warm before use
	Battery capacity too low for flight conditions	Replace battery or use a larger capacity battery
Aircraft will not Bind (during binding) to transmitter	Transmitter too near aircraft during binding process	Move powered transmitter a few feet from aircraft, disconnect and re-connect flight battery to aircraft
	Aircraft or transmitter is too close to large metal object, wireless source or another transmitter	Move aircraft and transmitter to another location and attempt binding again
	The bind plug is not installed correctly in the bind port	Install bind plug in bind port and bind the aircraft to the transmitter
	Flight battery/transmitter battery charge is too low	Replace/recharge batteries
	Bind switch or button not held long enough during bind process	Power off transmitter and repeat bind process. Hold transmitter bind button or switch until receiver is bound
Aircraft will not connect (after binding) to transmitter	Transmitter too near aircraft during connecting process	Move powered transmitter a few feet from aircraft, disconnect and re-connect flight battery to aircraft
	Aircraft or transmitter is too close to large metal object, wireless source or another transmitter	Move aircraft and transmitter to another location and attempt connecting again
	Bind plug left installed in bind port	Rebind transmitter to the aircraft and remove the bind plug before cycling power
	Aircraft bound to different model memory (ModelMatch™ radios only)	Select correct model memory on transmitter
	Flight battery/Transmitter battery charge is too low	Replace/recharge batteries
	Transmitter may have been bound to a different aircraft using different DSM protocol	Bind aircraft to transmitter
Control surface does not move	Control surface, control horn, linkage or servo damage	Replace or repair damaged parts and adjust controls
	Wire damaged or connections loose	Do a check of wires and connections, connect or replace as needed
	Transmitter is not bound correctly or the incorrect airplanes was selected	Re-bind or select correct airplanes in transmitter
	Flight battery charge is low	Fully recharge flight battery
	BEC (Battery Elimination Circuit) of the ESC is damaged	Replace ESC
Controls reversed	Transmitter settings are reversed	Perform the Control Direction Test and adjust the controls on transmitter appropriately
Motor power pulses then motor loses power	ESC uses default soft Low Voltage Cutoff (LVC)	Recharge flight battery or replace battery that is no longer performing
	Weather conditions might be too cold	Postpone flight until weather is warmer
	Battery is old, worn out, or damaged	Replace battery
	Battery C rating might be too small	Use recommended battery

AMA National Model Aircraft Safety Code

Effective January 1, 2018

A model aircraft is a non-human-carrying device capable of sustained flight within visual line of sight of the pilot or spotter(s). It may not exceed limitations of this code and is intended exclusively for sport, recreation, education and/or competition. All model flights must be conducted in accordance with this safety code and related AMA guidelines, any additional rules specific to the flying site, as well as all applicable laws and regulations.

As an AMA member I agree:

- I will not fly a model aircraft in a careless or reckless manner.
- I will not interfere with and will yield the right of way to all human-carrying aircraft using AMA's See and Avoid Guidance and a spotter when appropriate.
- I will not operate any model aircraft while I am under the influence of alcohol or any drug that could adversely affect my ability to safely control the model.
- I will avoid flying directly over unprotected people, moving vehicles, and occupied structures.
- I will fly Free Flight (FF) and Control Line (CL) models in compliance with AMA's safety programming.
- I will maintain visual contact of an RC model aircraft without enhancement other than corrective lenses prescribed to me. When using an advanced flight system, such as an autopilot, or flying First-Person View (FPV), I will comply with AMA's Advanced Flight System programming.
- I will only fly models weighing more than 55 pounds, including fuel, if certified through AMA's Large Model Airplane Program.
- I will only fly a turbine-powered model aircraft in compliance with AMA's Gas Turbine Program.
- I will not fly a powered model outdoors closer than 25 feet to any individual, except for myself or my helper(s) located at the flightline, unless I am taking off and landing, or as otherwise provided in AMA's Competition Regulation.
- I will use an established safety line to separate all model aircraft operations from spectators and bystanders.

Limited Warranty

What this Warranty Covers

Horizon Hobby, LLC, (Horizon) warrants to the original purchaser that the product purchased (the "Product") will be free from defects in materials and workmanship at the date of purchase.

What is Not Covered

This warranty is not transferable and does not cover (i) cosmetic damage, (ii) damage due to acts of God, accident, misuse, abuse, negligence, commercial use, or due to improper use, installation, operation or maintenance, (iii) modification of or to any part of the Product, (iv) attempted service by anyone other than a Horizon Hobby authorized service center, (v) Product not purchased from an authorized Horizon dealer, or (vi) Product not compliant with applicable technical regulations, or (vii) use that violates any applicable laws, rules, or regulations.

OTHER THAN THE EXPRESS WARRANTY ABOVE, HORIZON MAKES NO OTHER WARRANTY OR REPRESENTATION, AND HEREBY DISCLAIMS ANY AND ALL IMPLIED WARRANTIES, INCLUDING, WITHOUT LIMITATION, THE IMPLIED WARRANTIES OF NON-INFRINGEMENT, MERCHANTABILITY AND FITNESS FOR A PARTICULAR PURPOSE. THE PURCHASER ACKNOWLEDGES THAT THEY ALONE HAVE DETERMINED THAT THE PRODUCT WILL SUITABLY MEET THE REQUIREMENTS OF THE PURCHASER'S INTENDED USE.

Purchaser's Remedy

Horizon's sole obligation and purchaser's sole and exclusive remedy shall be that Horizon will, at its option, either (i) service, or (ii) replace, any Product determined by Horizon to be defective. Horizon reserves the right to inspect any and all Product(s) involved in a warranty claim. Service or replacement decisions are at the sole discretion of Horizon. Proof of purchase is required for all warranty claims. SERVICE OR REPLACEMENT AS PROVIDED UNDER THIS WARRANTY IS THE PURCHASER'S SOLE AND EXCLUSIVE REMEDY.

Limitation of Liability

HORIZON SHALL NOT BE LIABLE FOR SPECIAL, INDIRECT, INCIDENTAL OR CONSEQUENTIAL DAMAGES, LOSS OF PROFITS OR PRODUCTION OR COMMERCIAL LOSS IN ANY WAY, REGARDLESS OF WHETHER SUCH CLAIM IS BASED IN CONTRACT, WARRANTY, TORT, NEGLIGENCE, STRICT LIABILITY OR ANY OTHER THEORY OF LIABILITY, EVEN IF HORIZON HAS BEEN ADVISED OF THE POSSIBILITY OF SUCH DAMAGES. Further, in no event shall the liability of Horizon exceed the individual price of the Product on which liability is asserted. As Horizon has no control over use, setup, final assembly, modification or misuse, no liability shall be assumed nor accepted for any resulting damage or injury. By the act of use, setup or assembly, the user accepts all resulting liability. If you as the purchaser or user are not prepared to accept the liability associated with the use of the Product, purchaser is advised to return the Product immediately in new and unused condition to the place of purchase.

Law

These terms are governed by Illinois law (without regard to conflict of law principals). This warranty gives you specific legal rights, and you may also have other rights which vary from state to state. Horizon reserves the right to change or modify this warranty at any time without notice.

WARRANTY SERVICES

Questions, Assistance, and Services

Your local hobby store and/or place of purchase cannot provide warranty support or service. Once assembly, setup or use of the Product has been started, you must contact your local distributor or Horizon directly. This will enable Horizon to better answer your questions and service you in the event that you may need any assistance. For questions

or assistance, please visit our website at www.horizonhobby.com, submit a Product Support Inquiry, or call the toll free telephone number referenced in the Warranty and Service Contact Information section to speak with a Product Support representative.

Inspection or Services

If this Product needs to be inspected or serviced and is compliant in the country you live and use the Product in, please use the Horizon Online Service Request submission process found on our website or call Horizon to obtain a Return Merchandise Authorization (RMA) number. Pack the Product securely using a shipping carton. Please note that original boxes may be included, but are not designed to withstand the rigors of shipping without additional protection. Ship via a carrier that provides tracking and insurance for lost or damaged parcels, as Horizon is not responsible for merchandise until it arrives and is accepted at our facility. An Online Service Request is available at http://www.horizonhobby.com/content/service-center_render-service-center. If you do not have internet access, please contact Horizon Product Support to obtain a RMA number along with instructions for submitting your product for service. When calling Horizon, you will be asked to provide your complete name, street address, email address and phone number where you can be reached during business hours. When sending product into Horizon, please include your RMA number, a list of the included items, and a brief summary of the problem. A copy of your original sales receipt must be included for warranty consideration. Be sure your name, address, and RMA number are clearly written on the outside of the shipping carton.

NOTICE: Do not ship LiPo batteries to Horizon. If you have any issue with a LiPo battery, please contact the appropriate Horizon Product Support office.

Warranty Requirements

For Warranty consideration, you must include your original sales receipt verifying the proof-of-purchase date. Provided warranty conditions have been met, your Product will be serviced or replaced free of charge. Service or replacement decisions are at the sole discretion of Horizon.

Non-Warranty Service

Should your service not be covered by warranty, service will be completed and payment will be required without notification or estimate of the expense unless the expense exceeds 50% of the retail purchase cost. By submitting the item for service you are agreeing to payment of the service without notification. Service estimates are available upon request. You must include this request with your item submitted for service. Non-warranty service estimates will be billed a minimum of ½ hour of labor. In addition you will be billed for return freight. Horizon accepts money orders and cashier's checks, as well as Visa, MasterCard, American Express, and Discover cards. By submitting any item to Horizon for service, you are agreeing to Horizon's Terms and Conditions found on our website http://www.horizonhobby.com/content/service-center_render-service-center.

ATTENTION: Horizon service is limited to Product compliant in the country of use and ownership. If received, a non-compliant Product will not be serviced. Further, the sender will be responsible for arranging return shipment of the un-serviced Product, through a carrier of the sender's choice and at the sender's expense. Horizon will hold non-compliant Product for a period of 60 days from notification, after which it will be discarded.

10/15

Contact Information

Country of Purchase	Horizon Hobby	Contact Information	Address
United States of America	Horizon Service Center (Repairs and Repair Requests)	servicecenter.horizonhobby.com/ RequestForm/	2904 Research Rd Champaign, Illinois, 61822 USA
	Horizon Product Support (Product Technical Assistance)	productsupport@horizonhobby.com 877-504-0233	
	Sales	websales@horizonhobby.com 800-338-4639	
European Union	Horizon Technischer Service	service@horizonhobby.eu	Hanskampring 9 D 22885 Barsbüttel, Germany
	Sales: Horizon Hobby GmbH	+49 (0) 4121 2655 100	

FCC Information

FCC ID: BRWSPMSR6200A
Supplier's Declaration of Conformity
EFL Extra 300 1.3M PNP/BASIC (EFL11575, EFL115500)

This device complies with part 15 of the FCC Rules. Operation is subject to the following two conditions: (1) This device may not cause harmful interference, and (2) this device must accept any interference received, including interference that may cause undesired operation.

CAUTION: Changes or modifications not expressly approved by the party responsible for compliance could void the user's authority to operate the equipment.

NOTE: This equipment has been tested and found to comply with the limits for a Class B digital device, pursuant to part 15 of the FCC Rules. These limits are designed to provide reasonable protection against harmful interference in a residential installation. This equipment generates, uses and can radiate radio frequency energy and, if not installed and used in accordance with the instructions, may cause harmful

interference to radio communications. However, there is no guarantee that interference will not occur in a particular installation. If this equipment does cause harmful interference to radio or television reception, which can be determined by turning the equipment off and on, the user is encouraged to try to correct the interference by one or more of the following measures:

- Reorient or relocate the receiving antenna.
- Increase the separation between the equipment and receiver.
- Connect the equipment into an outlet on a circuit different from that to which the receiver is connected.
- Consult the dealer or an experienced radio/TV technician for help.

Horizon Hobby, LLC
 2904 Research Rd., Champaign, IL 61822
 Email: compliance@horizonhobby.com
 Web: HorizonHobby.com

IC Information

IC: 6157A-SPMSR6200A
CAN ICES-3 (B)/NMB-3(B)

This device contains license-exempt transmitter(s)/receiver(s) that comply with Innovation, Science, and Economic Development Canada's license-exempt RSS(s). Operation is subject to the following 2 conditions:

1. This device may not cause interference.
2. This device must accept any interference, including interference that may cause undesired operation of the device.

Compliance Information for the European Union

EU Compliance Statement:
EFL11575 Extra 300 1.3 M PNP: Hereby, Horizon Hobby, LLC declares that the device is in compliance with the following: EU EMC Directive 2014/30/EU.

EFL115500 Extra 300 1.3 M BNF BASIC: Hereby, Horizon Hobby, LLC declares that the device is in compliance with the following: EU Radio Equipment Directive 2014/53/EU.

The full text of the EU declaration of conformity is available at the following internet address: <https://www.horizonhobby.com/content/support-render-compliance>.

Wireless Frequency Range and Wireless Output Power:
 2404 – 2476MHz
 5.58dBm

EU Manufacturer of Record:
 Horizon Hobby, LLC
 2904 Research Road
 Champaign, IL 61822 USA

EU Importer of Record:
 Horizon Hobby, GmbH
 Hanskampring 9
 22885 Barsbüttel Germany

WEEE NOTICE:



This appliance is labeled in accordance with European Directive 2012/19/EU concerning waste of electrical and electronic equipment (WEEE). This label indicates that this product should not be disposed of with household waste. It should be deposited at an appropriate facility to enable recovery and recycling.



Recommended Receivers • Empfohlene Empfänger Récepteurs Recommandés • Ricevitori Raccomandati

PNP Only • Nur PNP • PNP Uniquement • Solo PNP

Part # Nummer Numéro Codice	Description	Beschreibung	Description	Descrizione
SPMAR631	AR631 6-Channel Coated Air Receiver	Ummantelter AR631-6-Kanal-Flugzeugempfänger	Récepteur aérien avec revêtement 6 canaux AR631	Ricevente aereo AR631 6 canali con rivestimento
	Telemetry Equipped Receivers	Empfänger mit Telemetrie	Récepteurs avec télémétrie	Riceventi con telemetria
SPMAR6600T	AR6600T 6-Channel Air Integrated Telemetry Receiver	AR6600T-6-Kanal-Flugzeugempfänger mit integrierter Telemetrie	Récepteur aérien avec télémétrie intégrée 6 canaux AR6600T	Ricevente aereo AR6600T 6 canali con telemetria integrata
SPMAR6270T	AR6270T 6-Channel Carbon Fuse Integrated Telemetry Receiver	AR6270T-6-Kanal-Karbon-Sicherungempfänger mit integrierter Telemetrie	Récepteur à fusibles en carbone avec télémétrie intégrée 6 canaux AR6270T	Ricevente AR6270T 6 canali con telemetria integrata per fusoliera in carbonio
SPMAR8010T	AR8010T 8-Channel Air Integrated Telemetry Receiver	AR8010T-8-Kanal-Flugzeugempfänger mit integrierter Telemetrie	Récepteur aérien avec télémétrie intégrée 8 canaux AR8010T	Ricevente aereo AR8010T 8 canali con telemetria integrata
SPMAR9030T	AR9030T 9-Channel Air Integrated Telemetry Receiver	AR9030T-9-Kanal-Flugzeugempfänger mit integrierter Telemetrie	Récepteur aérien avec télémétrie intégrée 9 canaux AR9030T	Ricevente aereo AR9030T 9 canali con telemetria integrata
	AS3X Equipped Receivers	AS3X-Empfänger	Récepteurs avec AS3X	Riceventi con AS3X
SPMAR631	AR631 6-Channel AS3X Sport Receiver	AR631-6-Kanal-AS3X-Sportempfänger	Récepteur AS3X sport 6 canaux AR631	AR631 ricevitore sportivo a 6 canali AS3X
	AS3X and Telemetry Equipped Receivers	AS3X- und Telemetrieempfänger	Récepteurs avec AS3X et télémétrie	Riceventi con AS3X e telemetria
SPMAR7350	AR7350 7-Channel AS3X Receiver with Integrated Telemetry	AR7350-7-Kanal-Empfänger	Récepteur 7 canaux AR7350	Ricevente AR7350 7 canali
SPMAR9350	AR9350 7-Channel AS3X Receiver with Integrated Telemetry	AR9350-7-Kanal-Empfänger	Récepteur 7 canaux AR9350	Ricevente AR9350 7 canali
	Telemetry Sensors*	Telemetriesensoren*	Capteurs télémétriques*	Sensori di telemetria*
SPMA9574	Aircraft Telemetry Airspeed Indicator	Flugzeugtelemetrie-Luftgeschwindigkeitsanzeige	Indicateur télémétrique de vitesse aérodynamique pour avion	Telemetria per aerei - Anemometro
SPMA9589	Aircraft Telemetry Altitude and Variometer Sensor	Flugzeugtelemetrie-Höhen- und Variometer-Sensor	Indicateur télémétrique d'altitude et variomètre pour avion	Telemetria per aerei - Sensore altimetrico e variometro
SPMA9558	Brushless RPM Sensor	Bürstenloser Drehzahlsensor	Capteur de tr/min sans balai	Sensore RPM brushless
SPMA9605	Aircraft Telemetry Flight Pack Battery Energy Sensor	Flugzeugtelemetrie-Flugakkupack-Energiesensor	Capteur télémétrique de niveau de batterie de vol pour avion	Telemetria per aerei - Sensore per la misura dell'energia della batteria di bordo
SPMA9587	Aircraft Telemetry GPS Sensor	Flugzeugtelemetrie-GPS-Sensor	Capteur télémétrique GPS pour avion	Telemetria per aerei - Sensore GPS

*Not compatible with BNF, Telemetry receiver required

*Nicht kompatibel mit BNF, Telemetrieempfänger erforderlich

*Non compatible avec les modèles BNF, récepteur télémétrique requis

*Non compatibile con BNF, necessita di ricevente con telemetria

Replacement Parts • Ersatzteile • Pièces de rechange • Pezzi di ricambio

Part # Nummer Numéro Codice	Description	Beschreibung	Description	Descrizione
EFL11576	Fuselage w/Rudder	Rumpf mit Seitenruder	Fuselage avec gouverne	Fusoliera con timone
EFL11577	Wing	Tragflächen	Aile	Ali
EFL11578	Horizontal Stabilizer	Höhenleitwerk	Stabilisateur	Stabilizzatore orizzontale
EFL11579	Cowl	Motorhaube	Capot	Naca motore
EFL11580	Canopy	Kabinenhaube	Verrière	Calotta
EFL11581	Landing Gear Set	Fahrwerk	Train d'atterrissage	Set carrello
EFL11582	Tailwheel Set	Spornradsatz	Roulette de queue	Set ruota posteriore
EFL11583	Spinner	Spinner	Cône	Ogiva
EFL11584	Battery Cover	Akkuhaube	Trappe de batterie	Sportello batteria
EFL11585	Bottom Cover	Untere Abdeckung	Couvercle inférieur	Coperchio inferiore
EFL11586	Linkage Rod	Gestänge	Tringlerie	Aste comandi
EFL11587	Screw Set	Schraubensatz	Ensemble de vis	Set di viti
EFL11588	Wing Tube	Tragfl ächenverbinder	Clé d'aile	Tubo dell'ala
EFL11589	Decal Sheet	Dekorbogen	Planche de décoration	Foglio decorazioni adesive
EFL11590	Landing Gear Insert	Fahrwerkshalter	Bague de train d'atterrissage	Fermo carrello d'atterraggio
EFL11591	Pilot	Pilot	Pilote	Pilota
EFL11592	Propeller	Propeller	Hélice	Elica
EFL11593	Motor Board	Motorhalter	Conseil moteur	Supporto motore
EFL11594	X Motor Mount	X Motorhalter	Support moteur X	X Supporto motore
EFL11595	Motor Shaft	Motorwelle	Axe moteur	Albero motore
EFL11596	Motor	Motor	Moteur	Motore
EFL11597	ESC 60A	60A ESC Regler	Contrôleur 60A	ESC 60A
EFL11598	23g MG Servo	23 Gram Servo	Servo 23 gr	Servocomando 23 g

Optional Parts • Optionale Bauteile • Pièces optionnelles • Pezzi opzionali

Part # Nummer Numéro Codice	Description	Beschreibung	Description	Descrizione
EFLA250	Park Flyer Tool Assortment, 5 pc	Park Flyer Werkzeugsortiment, 5 teilig	Assortiment d'outils park flyer, 5pc	Park Flyer assortimento attrezzi, 5 pc
EFLAEC302	EC3 Battery Connector, Female (2)	EC3 Akkukabel, Buchse (2)	Prise EC3 femelle (2pc)	EC3 Connettore femmina batteria (2)
EFLAEC303	EC3 Device/Battery Connector, Male/ Female	EC3 Kabelsatz, Stecker/Buchse	Prise EC3 male/femelle	EC3 Connettore batteria maschio/ femmina
SPMX22004S30	14.4V 4S 30C 2200mAh Li-Po IC3	14.4V 4S 30C 2200mAh LiPo IC3	Li-Po IC3 4S 14,4V 2200mA 30C	14.4V 4S 30C 2200MAH Li-Po IC3
EFLB32004S30	14.4V 4S 30C 3200mAh Li-Po	14.4V 4S 30C 3200mAh LiPo	Li-Po 4S 14,4V 3200mA 30C	14.4V 4S 30C 3200MAH Li-Po
SPMX22003S30	11.1V 3S 30C 2200mAh LiPo IC3	11.1V 3S 30C 2200mAh LiPo IC3	LiPo IC3 3S 11,1V 2200mAh 30C	11.1V 3S 30C 2200mAh LiPo IC3
SPMX32003S30	11.1V 3S 30C 3200mAh Smart LiPo IC3	11.1V 3S 30C 3200mAh Smart LiPo IC3	Smart LiPo IC3 11,1V 3S 3200mAh 30C	11.1V 3S 30C 3200mAh Smart LiPo IC3
DYNC3005	Passport Duo 400W Dual AC/DC Touch Charger	Passport Duo 400 W Duales Wechsel-/ Gleichstrom-Ladegerät	Chargeur Passport Duo 400W AC/DC, écran tactile	Caricabatteria AC/DC Passport Duo Touch 400 W
SPMA3081	AS3X Programming Cable - Audio Interface	Spektrum Audio-Interface AS3X Empfänger Programmierkabel	Câble de programmation audio AS3X pour smartphone	Cavo di programmazione AS3X - Interfaccia audio
SPMA3065	AS3X Programming Cable - USB Interface	Spektrum USB-Interface AS3X Empfänger Programmierkabel	Câble de programmation USB AS3X pour PC	Cavo di programmazione AS3X - Interfaccia USB
SPMXBC100	Li-Po Cell Voltage Checker	Li-Po Cell Voltage Checker	Testeur de tension d'éléments Li-Po	Voltmetro verifica batterie LiPo
DYN1405	Li-Po Charge Protection Bag, Large	Dynamite LiPoCharge Protection Bag groß	Sac de charge Li-Po, grand modèle	Sacchetto grande di protezione per carica LiPo
DYN1400	Li-Po Charge Protection Bag, Small	Dynamite LiPoCharge Protection Bag klein	Sac de charge Li-Po, petit modèle	Sacchetto piccolo di protezione per carica LiPo
	DXe DSMX 6-Channel Transmitter	Spektrum DXe DSMX 6-Kanal Sender	Emetteur DXe DSMX 6 voies	DXe DSMX Trasmettitore 6 canali
	DX6eDSMX 6-Channel Transmitter	Spektrum DX6e DSMX 6-Kanal Sender	Emetteur DX6e DSMX 6 voies	DX6e DSMX Trasmettitore 6 canali
	DX6 DSMX 6-Channel Transmitter	Spektrum DX6 DSMX 6-Kanal Sender	Emetteur DX6 DSMX 6 voies	DX6 DSMX Trasmettitore 6 canali
	DX8e DSMX 8-Channel Transmitter	Spektrum DX8e DSMX 8 Kanal Sender	Emetteur DX8e DSMX 8 voies	DX8e DSMX Trasmettitore 8 canali
	DX8G2 DSMX 8-Channel Transmitter	Spektrum DX8G2 DSMX 8 Kanal Sender	Emetteur DX8G2 DSMX 8 voies	DX8G2 DSMX Trasmettitore 8 canali
	DX9 DSMX 9-Channel Transmitter	Spektrum DX9 DSMX 9 Kanal Sender	Emetteur DX9 DSMX 9 voies	DX9 DSMX Trasmettitore 9 canali
	iX12 DSMX 12-Channel Transmitter	Spektrum iX12 DSMX 12 Kanal Sender	Emetteur iX12 DSMX 12 voies	iX12 DSMX Trasmettitore 12 canali
	NX6 6-Channel Transmitter	NX6 6 Kanal Sender	Emetteur NX6 6 voies	NX6 Trasmettitore 6 canali
	NX8 8-Channel Transmitter	NX8 8 Kanal Sender	Emetteur NX8 8 voies	NX8 Trasmettitore 8 canali
	NX10 10-Channel Transmitter	NX10 10 Kanal Sender	Emetteur NX10 10 voies	NX10 Trasmettitore 10 canali



Extra 300 1.m

© 2020 Horizon Hobby, LLC.

E-flite, DSM, DSM2, DSMX, Bind-N-Fly, BNF, the BNF logo, Plug-N-Play, AS3X, SAFE, the SAFE logo, ModelMatch, Passport, Prophet, EC3, and the Horizon Hobby logo are trademarks or registered trademarks of Horizon Hobby, LLC.

The Spektrum trademark is used with permission of Bachmann Industries, Inc.

Futaba is a registered trademark of Futaba Denshi Kogyo Kabushiki Kaisha Corporation of Japan.

All other trademarks, service marks and logos are property of their respective owners.

US 8,672,726. US 9,056,667. US 9,753,457. US 10,078,329. US 9,930,567. US 10,419,970. Other patents pending.

<http://www.e-fliterc.com/>