

Installation Guide

beta

ECOFLOW SMART GATEWAY (200A)

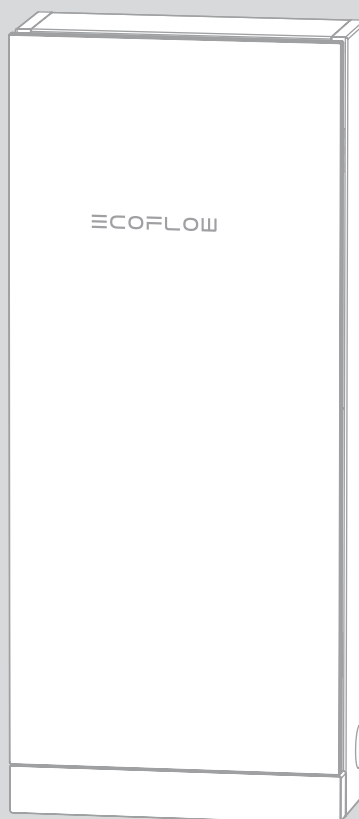

Document

For the latest documents, please scan the QR code or visit:
Q <https://homebattery.ecoflow.com/documentation>

Contents

1	Safety Instructions
1	Disclaimer
1	Symbol Conventions
1	Safety Symbols
1	Important Safety Instructions
2	Technical Specifications
2	Compliance
2	FCC Compliance Statement
2	Industry Canada Compliance
3	Conformidad con la NOM
4	Unpacking and Preparation
4	What's in the Box
4	Preparing Materials and Tools
5	Product Overview
6	Installation
6	Cable Entry Setting
7	Mounting
9	Sub-Panel Setting
10	Wiring
11	Communication
12	EcoFlow Smart Inlet Box Installation
12	Pre-Installation: Site Planning
12	Step 1: Unscrew the Cover of the Inlet Box
12	Step 2: Mount the Inlet Box on the Wall
13	Step 3: Wiring
14	Step 4: Re-Install the Cover of the Inlet Box
14	Step 5: Install Overcurrent Protection Devices (Optional)
15	Completing Installation
16	Reset Relays If Failure Occurs
17	Energizing after the Whole System Installation
17	System Commissioning
17	System Commissioning via EcoFlow App
19	Circuit Breaker Compatibility
19	Main Circuit Breaker
19	Branch Circuit Breaker





Safety Instructions

Disclaimer





This product includes essential printed documentation required for setup and basic usage. For detailed manuals, resources, and the most up-to-date information about the product, visit <https://homebattery.ecoflow.com/documentation>. Fully read and understand the product documentation prior to use. Improper use may result in serious injury, damage, or property loss. By using this product, you agree to and accept all terms outlined in the product documentation. EcoFlow is not liable for losses, damages, or injuries caused by misuse or non-compliance.

Symbol Conventions

The following table describes the symbol conventions used in this document. Please note that all the instructions and cautions on the equipment or in related documents are only supplements to local laws and regulations.

Symbol	Description
 DANGER	Indicates a hazard with a high level of risk which, if not avoided, will result in death or serious injury.
 WARNING	Indicates a hazard with a medium level of risk which, if not avoided, could result in death or serious injury.
 CAUTION	Indicates a hazard with a low level of risk which, if not avoided, could result in minor or moderate injury.
NOTICE	Indicates a potentially hazardous situation that, if not avoided, could result in equipment damage, data loss, performance deterioration, or unanticipated results. NOTICE is used to address practices not related to personal injury.
	Indicates additional information that promotes understanding of the product or a topic.

Safety Symbols

Symbol	Description
	Caution! Risk of Danger 1. Disconnect the equipment from all voltage sources before servicing. 2. Do not disconnect under load.
	Caution! Risk of Electric Shock Do not remove the cover (or back). No user serviceable parts inside. Refer servicing to qualified service personnel.
	Refer to Documentation Read all documentation supplied with the product.
	Grounding Indicates the position for connecting the protective earthing (PE) cable.

Important Safety Instructions

General

WARNING

1. Intended use: suitable for use as service equipment.
2. These servicing instructions are for use by qualified personnel only. To reduce the risk of electric shock, do not perform any servicing other than that specified in the operating instructions unless you are qualified to do so.
3. Please read the product document carefully before installing, operating, or servicing this equipment.
4. Installation of this equipment must conform to local standards, national electrical safety standards, and the manufacturer's instructions.
5. MORE THAN ONE LIVE CIRCUIT. DISCONNECT ALL SOURCES OF SUPPLY BEFORE SERVICING.
6. There is a high possibility of electric shock or serious burns due to the high voltages in the equipment.

Operation

WARNING

1. Use appropriate personal protective equipment (PPE) and follow safe electrical work practices.
2. Wiring methods in accordance with the National Electrical Code, ANSI/NFPA 70 are to be used.
3. Risk of Electric Shock: Do not touch exposed electrical cables or parts with bare hands.
4. Be cautious to prevent injury when moving heavy objects.
5. Do not install or operate the equipment in an area where flammable or explosive materials are stored.
6. Inspect the equipment and cables for damage before installing. Do not install the equipment or cables if damaged in any way.
7. Turn off all power supplying this equipment before installation. Disconnect each circuit individually before servicing. AC voltage sources are terminated inside this equipment.
8. Always use a properly rated voltage sensing device to confirm power is off.
9. During the drilling process, cover the interior equipment to prevent debris from falling into the equipment, and clear the debris after drilling to prevent interference with the equipment.
10. Do not damage, smear or cover any warning labels on the device. All labels must be visible after installation.
11. Before operating the equipment, check the electrical connections to ensure that the equipment is reliably and permanently grounded.
12. Do not place any kind of objects on top of the product during operation.
13. To completely de-energize the product, you MUST open the upstream breakers as well as physically unplug all batteries or power. Failure to do so may present a shock hazard.
14. Do not place or install flammable or potentially explosive objects near the product or in explosive atmospheres.
15. Do not insert foreign objects into any part of the equipment.
16. Do not connect life-support systems, other medical equipment, or any other use where product failure could lead to injury to persons or loss of life to circuits which can be remotely switched.
17. Replace all devices, doors, and covers before turning on power to this equipment.

⚠ CAUTION

1. In the case of cables damaged, it must be replaced by the manufacturer, customer service or qualified personnel to prevent a safety hazard.
2. Do not use solvents to clean the equipment.
3. Do not use parts or accessories other than those specified for use with the equipment.
4. When installing the equipment, the screws need to be tightened according to the specification torque using a special tool.

Environment

⚠ WARNING

1. Do not install or operate the equipment in extreme weather events such as lightning, snow, heavy rain, strong wind and so on.
2. Install the equipment in a location that prevents damage from flooding. Ensure that no water sources are above or near the equipment, including down spouts, sprinklers, or faucets.

⚠ CAUTION

1. The equipment must be disposed of according to local codes and regulations.
2. Keep out of reach of children or animals.
3. This product is designed for residential use only.

Technical Specifications

General	
Model	EF-ATS-001
Dimensions	905 × 385 × 188 mm (35.63 × 15.16 × 7.40 in)
Net Weight	65.5±0.4 lb (29.7±0.2 kg)
Enclosure Protection	NEMA 3R, Rainproof
Installation Method	Surface or semi-flush mounting
Number of Load Branches	80A × 2, 60A × 4
System Electrical Parameter	
Grid Connection	L1/L2/N/PE, Split phase
Overvoltage Category	IV
Rated Input Voltage	120/240V, 60Hz
Maximum Continuous Current	160A
Busbar Rating	240A
Maximum Input Short-circuit Current	22kA rms
Self-consumption at Night	< 5W
Communication Method	Bluetooth, WLAN, Ethernet, CAN, RS485

Certificates	UL67, UL916, UL1008, UL1012
Environment	
Operating Temperature	-22°F to 122°F (-30°C to 50°C)
Storage Temperature	-22°F to 122°F (-30°C to 50°C)
Operating Humidity	Up to 100% RH, condensing
Maximum Operating Altitude	≤ 9,842 ft (3,000 m)

Compliance

FCC Compliance Statement

Any Changes or modifications not expressly approved by the party responsible for compliance could void the user's authority to operate the equipment.

This device complies with part 15 of the FCC Rules. Operation is subject to the following two conditions:

- (1) This device may not cause harmful interference, and
- (2) this device must accept any interference received, including interference that may cause undesired operation.

This equipment has been tested and found to comply with the limits for a Class B digital device, pursuant to Part 15 of the FCC Rules. These limits are designed to provide reasonable protection against harmful interference in a residential installation. This equipment generates uses and can radiate radio frequency energy and, if not installed and used in accordance with the instructions, may cause harmful interference to radio communications. However, there is no guarantee that interference will not occur in a particular installation. If this equipment does cause harmful interference to radio or television reception, which can be determined by turning the equipment off and on, the user is encouraged to try to correct the interference by one of the following measures:

- Reorient or relocate the receiving antenna.
- Increase the separation between the equipment and receiver.
- Connect the equipment into an outlet on a circuit different from that to which the receiver is connected.
- Consult the dealer or an experienced radio/TV technician for help.

RF exposure statement

This equipment complies with FCC radiation exposure limits set forth for an uncontrolled environment. This equipment should be installed and operated with minimum distance 20 cm between the radiator and your body.

Industry Canada Compliance

This device complies with Industry Canada licence-exempt RSS standard(s)

Operation is subject to the following two conditions:

- (1) this device may not cause interference, and
- (2) this device must accept any interference, including interference that may cause undesired operation of the device.

Le présent appareil est conforme aux CNR d'Industrie Canada applicables aux appareils radio exempts de licence.

L'exploitation est autorisée aux deux conditions suivantes:

- (1) l'appareil ne doit pas produire de brouillage, et
- (2) l'utilisateur de l'appareil doit accepter tout brouillage radioélectrique subi, même si le brouillage est susceptible d'en

compromettre le fonctionnement.

This Class B digital apparatus complies with Canadian ICES-003.

Cet appareil numérique de la classe B est conforme à la norme NMB-003 du Canada.

CAN ICES(B) / NMB(B)

RF exposure statement

This equipment meets the exemption from the routine evaluation limits in section 2.5 of RSS-102. It should be installed

and operated with a minimum distance of 20 cm between the radiator and any part of your body.

Cet équipement est conforme à l'exemption des limites d'évaluation habituelle de la section 2.5 de la norme RSS-102. Il doit être installé et utilisé à une distance minimale de 20 cm entre le radiateur et toute partie de votre corps.









Conformidad con la NOM

La operación de este equipo está sujeta a las siguientes dos condiciones: (1) es posible que este equipo o dispositivo no cause interferencia perjudicial y (2) este equipo o dispositivo debe aceptar cualquier interferencia, incluyendo la que pueda causar su operación no deseada.

Lea detenidamente este manual antes de usar el producto y consérvelo para futuras consultas.

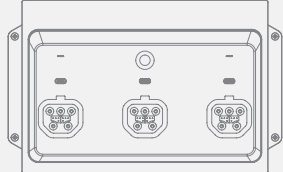

Unpacking and Preparation

I What's in the Box

 <p>EcoFlow Smart Home Panel 3 (32 Circuits) (the door and deadfront cover packaged separately)</p>	 <p>Mark-off template</p>	 <p>Screws ST5.5x32 mm (x9)</p>	 <p>Breaker hold-down (x8)</p>
 <p>EcoFlow Smart Inlet Box (Smart Home Panel 2 Upgrade) (x1)</p>	 <p>EcoFlow Smart Inlet Box Connection Cable (5P8 Port to 5P8 Port) (x1)</p>	 <p>Screws M3x8 mm (x4)</p>	 <p>Screw PT4x10 mm (x1)</p>

I Preparing Materials and Tools

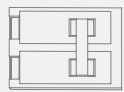
• MATERIALS

 <p>Main circuit breaker: 100-200A Branch circuit breaker: 125A Max, AFCI/ GFCI supported, plug-in type <i>*See "Circuit Breaker Compatibility" for details.</i></p>	 <p>Conductors for grid supply, backup power, and loads, rated to a minimum of 75°C (165°F) <i>*See "Wiring" to check the wire specification.</i></p>	 <p>Cable for Ethernet and the smart inlet box communication: CAT6, T568B straight-through, shielded, marked as STP or SFTP</p>
---	--	--

• STANDARD INSTALLATION TOOLS

 <p>Allen bits 1/4, 5/16, and 3/16 #4 slotted driver PH3 screw driver</p>	 <p>Other tools: cable cutter, level, marker, steel measuring tape</p>	 <p>PPE includes but not limited: safety goggles, safety shoes, safety gloves</p>
--	---	--

Product Overview

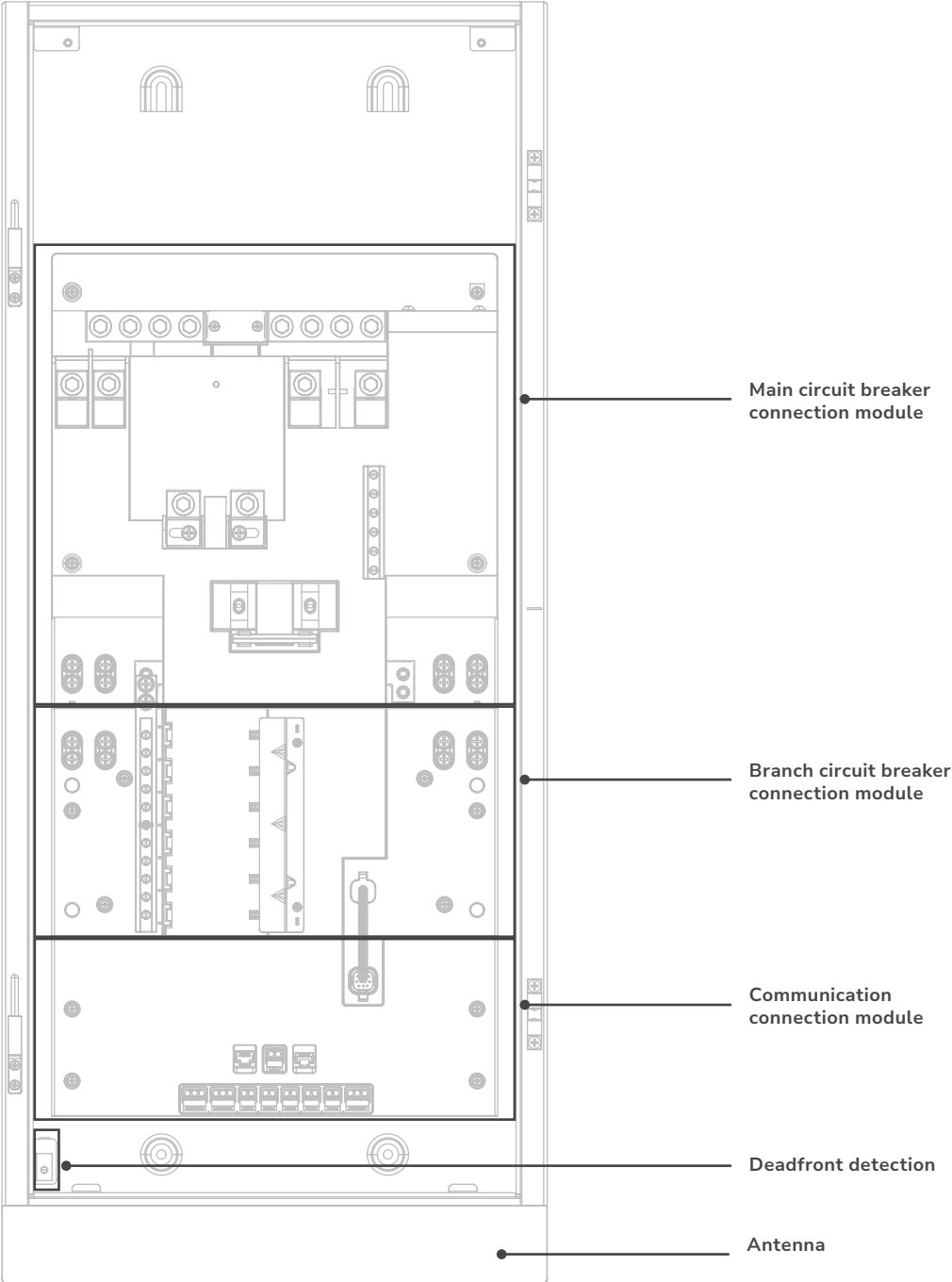

Installation

I Cable Entry Setting

5 preset expandable knockouts: 1-7/8" knockouts for 1-1/2" conduits

If you need to drill more cable entries, cover the interior equipment to prevent debris from falling into the equipment. Clear the debris after drilling to prevent interference with the equipment. A hydraulic hole puncher is recommended.

Allowable entry locations are the yellow highlighted area below.

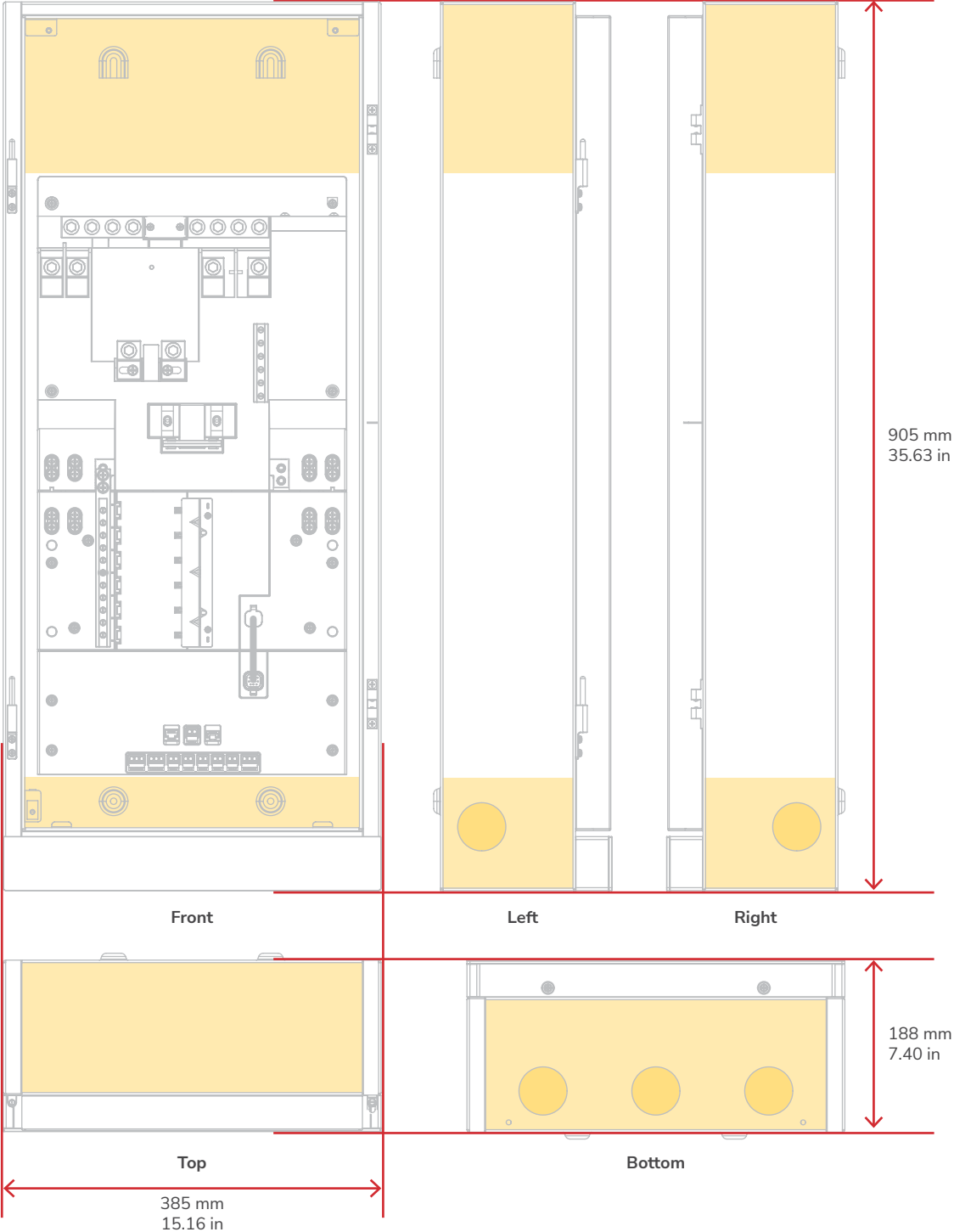

I Mounting

The panel supports surface or semi-flush mounting.

- **CLEARANCE**

Keep 1.5 inches from the door swing side to ensure the panel door can open to 90°. In case of semi-flush mounting, the depth of recessing the product into the wall must not exceed 4-3/4" (120.5 mm). Otherwise, it limits the access of the panel.

The work space, main circuit breaker, shall be clear and extend from the grade, floor, or platform to a height of 2 m (6-1/2 ft) or the height of the equipment, whichever is greater.

Other equipment that is associated with the electrical installation and is located above or below the electrical equipment shall be permitted to extend not more than 150 mm (6 in.) beyond the front of the electrical equipment.

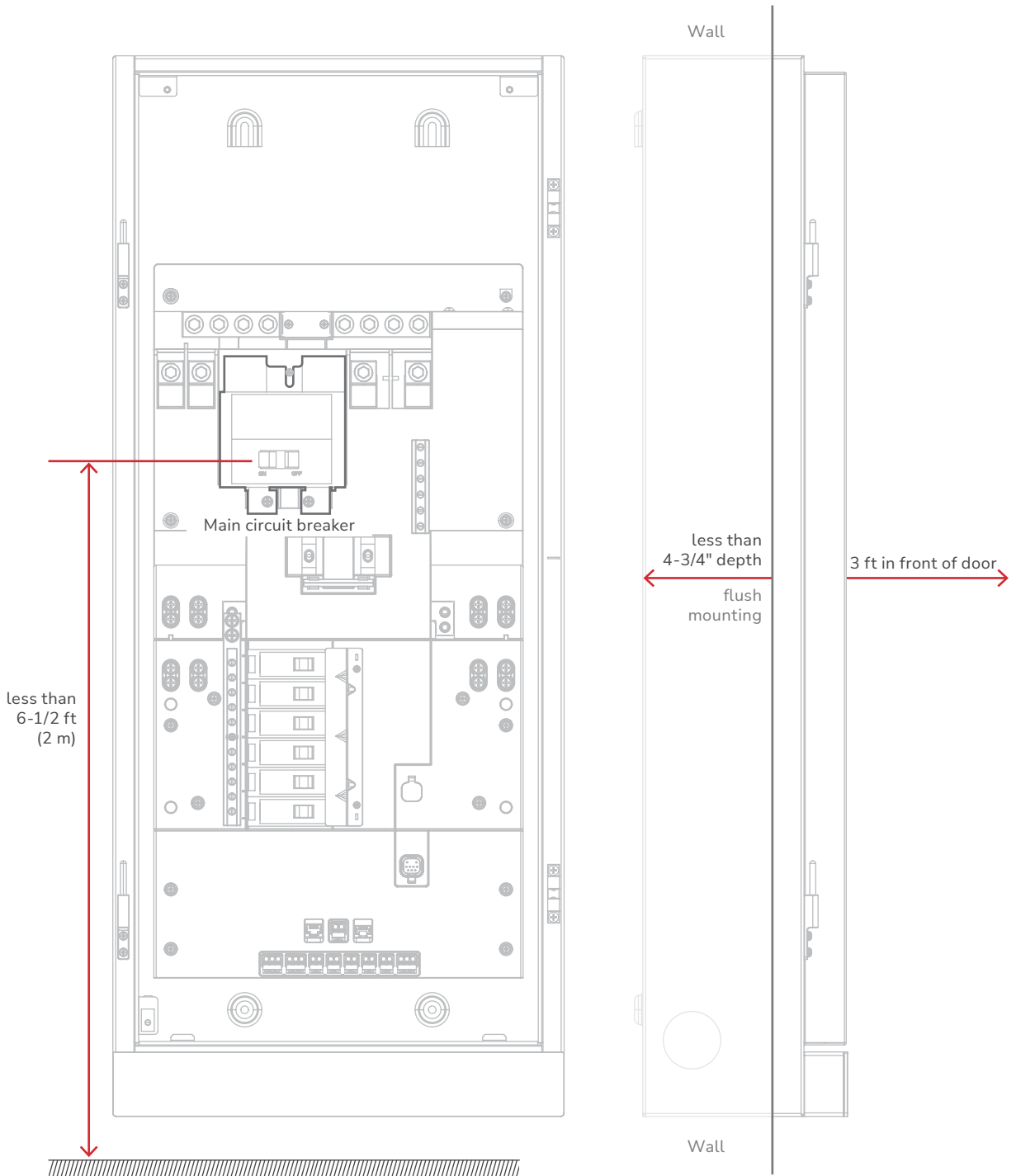

• MOUNTING THE PANEL

Mark and pre-install four screws into the wall, leaving approximately 1/3 of each screw exposed. Then, mount the panel onto the screws and fully tighten all four screws to secure it.

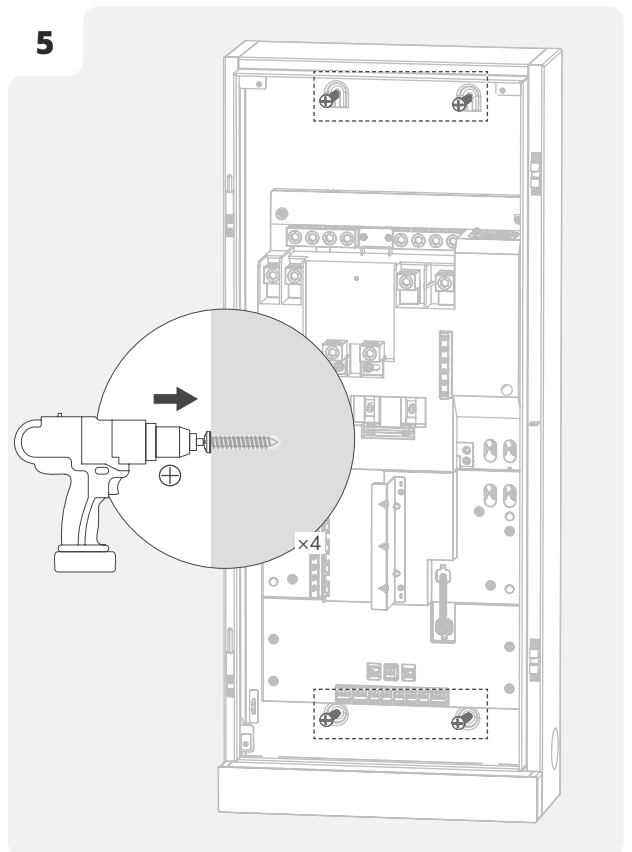
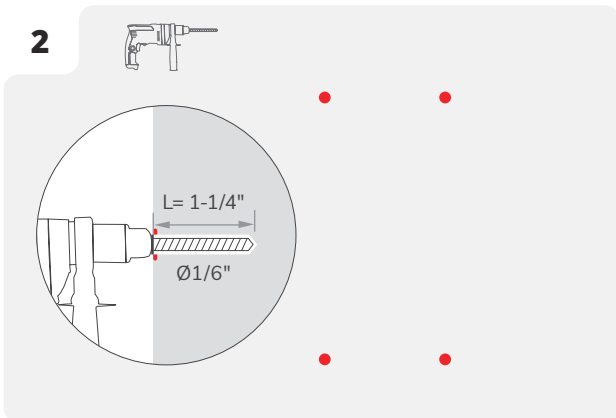
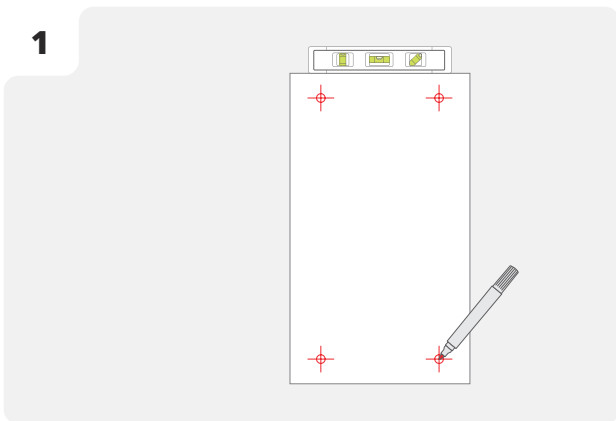
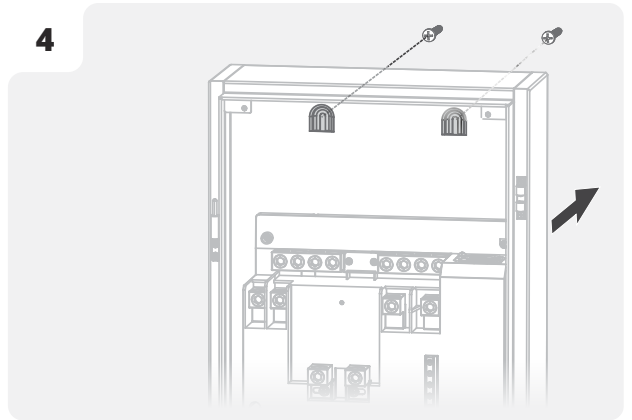
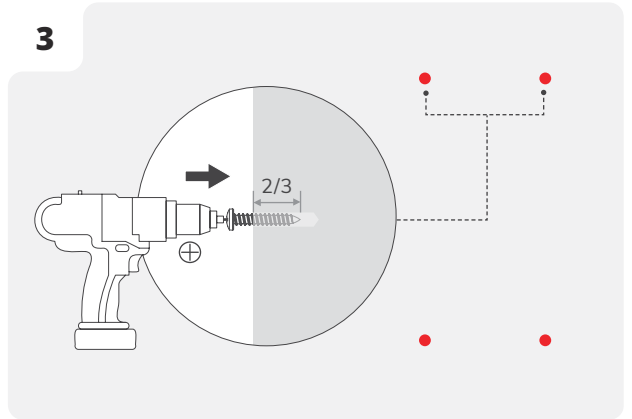
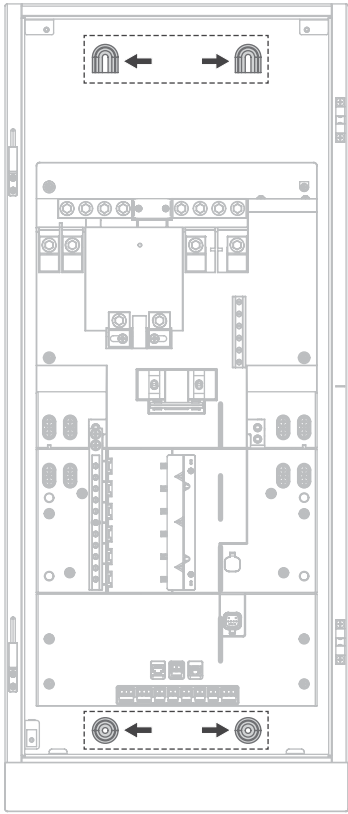

I Sub-Panel Setting

This panel is suitable for use as service entrance equipment. When used as a sub-panel, unscrew the bonding on the main breaker connection module.

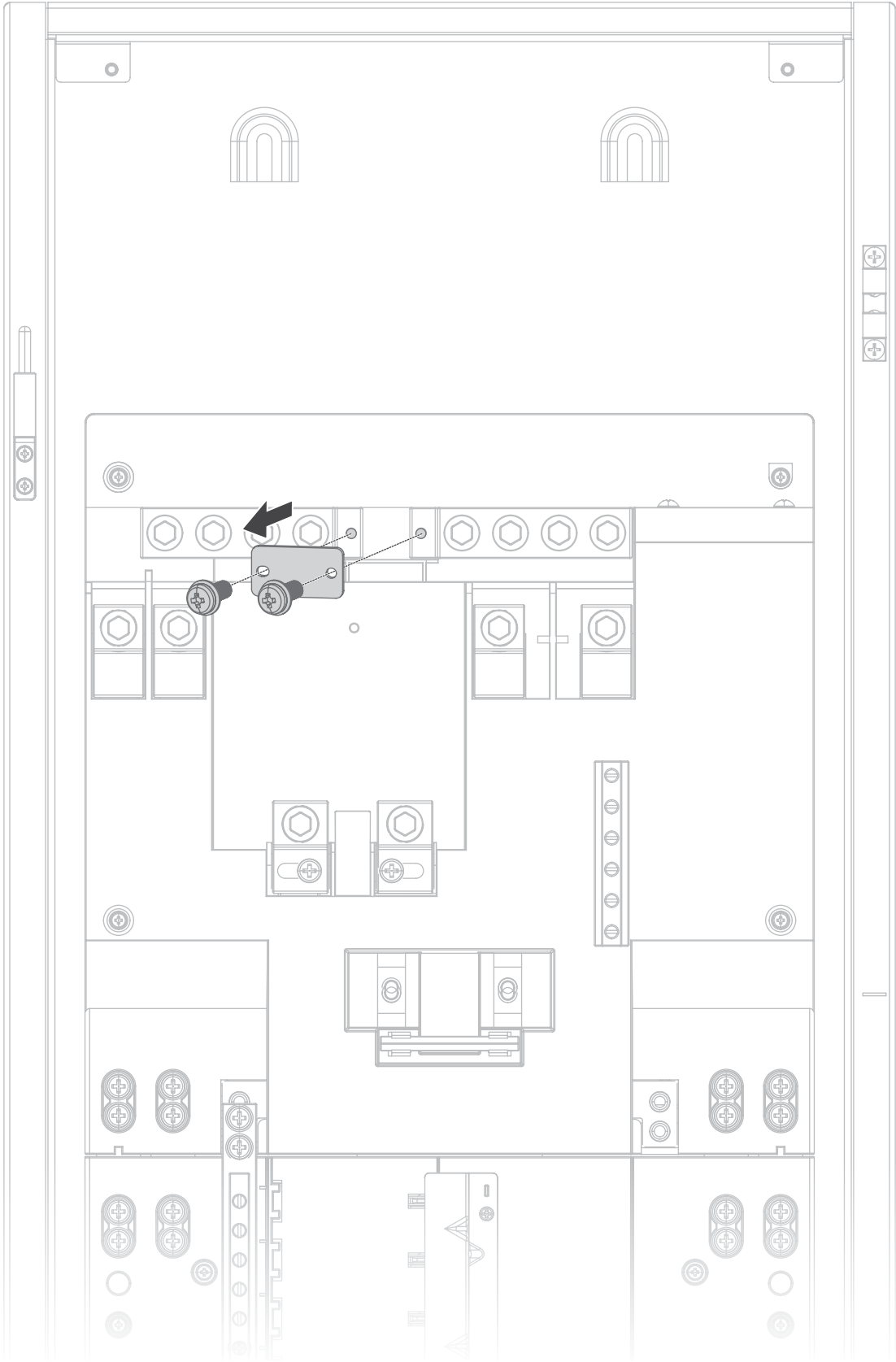

I Wiring



- Risk of electric shock. Before wiring, make sure the power is off. Ensure that main and branch circuit breakers are in the OFF position.

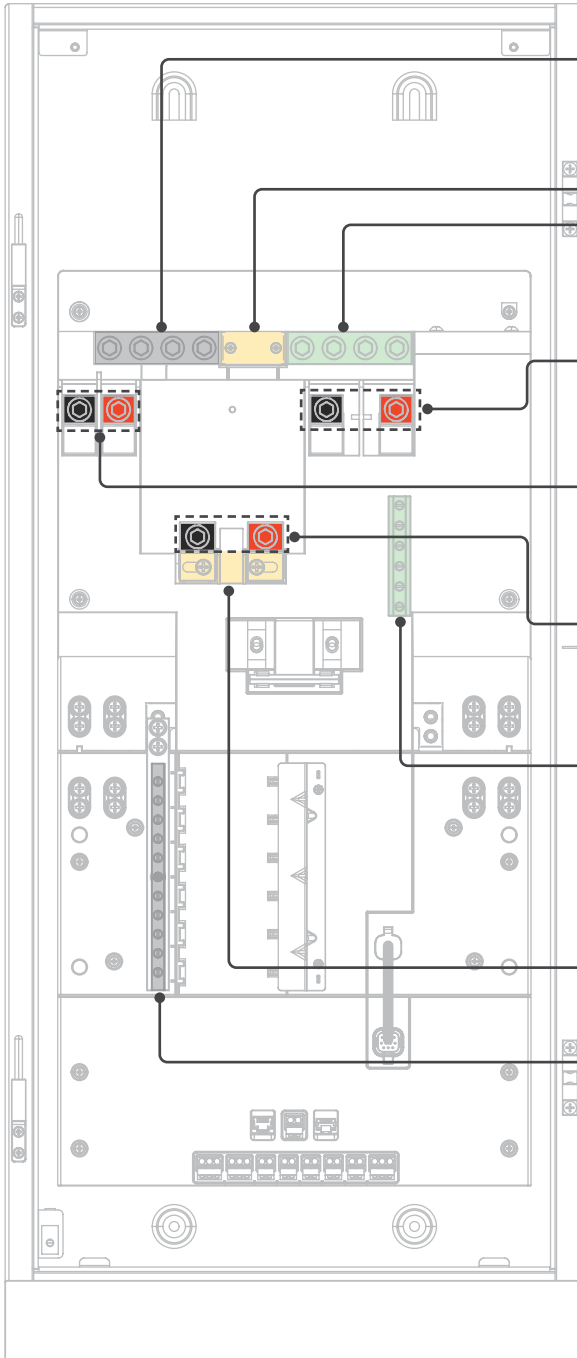

Neutral busbars

Wire size: 6 AWG-250 kcmil
Strip: 7/8 in.
Torque: 250 - 275 in-lbs (28.2 - 31.1 Nm)

Main bonding jumper

Ground busbars

Wire size: 6 AWG-250 kcmil
Strip: 7/8 in.
Torque: 250 - 275 in-lbs (28.2 - 31.1 Nm)

L1 / L2 lug (battery connection box)

Wire size: 6 AWG-250 kcmil
Strip: 13/16 in
Torque: 250 - 275 in-lbs (28.2 - 31.1 Nm)

L1 / L2 lug (backup load output)

Wire size: 6 AWG-250 kcmil
Strip: 7/8 in.
Torque: 250 - 275 in-lbs (28.2 - 31.1 Nm)

L1 / L2 Lug (if not install main breaker)

Wire size: 6 AWG-250 kcmil
Strip: 13/16 in.
Torque: 250 - 275 in-lbs (28.2 - 31.1 Nm)

Ground busbars

Wire size: 14 AWG-4 AWG
Strip: 3/8 in
Torque: 20 in-lbs (2.3 Nm) for #14-10
25 in-lbs (2.8 Nm) for #8
35 in-lbs (4.0 Nm) for #6-4
Number: 6 pcs

Main circuit breaker installation

Neutral busbars

Wire size: 14 AWG-4 AWG
Strip: 3/8 in.
Torque: 20 in-lbs (2.3 Nm) for #14-10
25 in-lbs (2.8 Nm) for #8
35 in-lbs (4.0 Nm) for #6-4
Number: 12 pcs

I Communication

• COMMUNICATION PORT DEFINITION

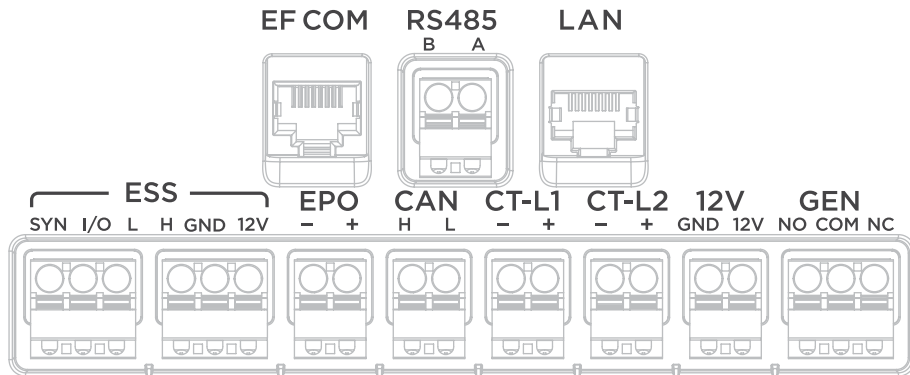

Communication Port	Definition
EF COM	Connects with EcoFlow Smart Inlet Box
RS485	Reserved
LAN	Ethernet connection
ESS	3 pins x 2, connects with EcoFlow OCEAN Pro Hybrid Inverter
EPO	When connecting with ESS, you don't need to connect with EPO. If not, connect EPO according to the local regulation.
CAN	EV charger
CT1	Connects with CT
CT2	Connects with CT
12V	Reserved
GEN	Connects with generator

EcoFlow Smart Inlet Box Installation



- Mounting the battery connection box upside down is not recommended.

I Pre-Installation: Site Planning

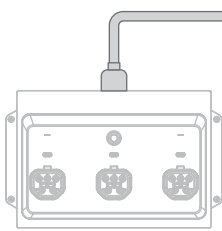

Enclosure NEMA 1
Install the box indoors and avoid water



Enclosure NEMA 3R
Installed the panel indoors or outdoors

I Step 1: Unscrew the Cover of the Inlet Box

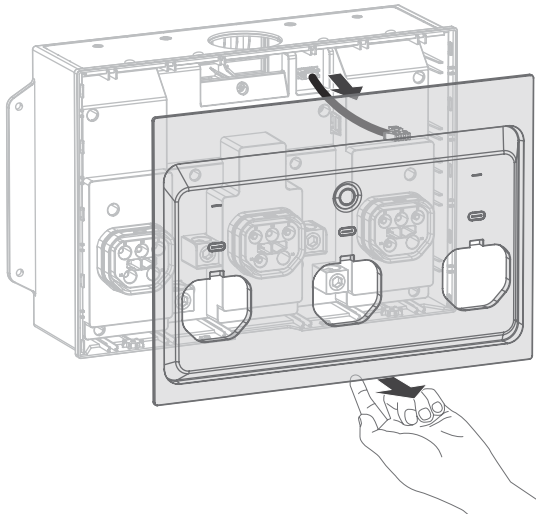
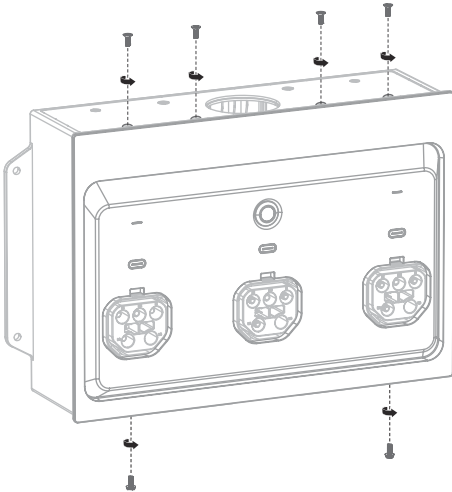

I Step 2: Mount the Inlet Box on the Wall

